

VARIANTS	
PART NO.	COLOUR
FCR7350B	BLACK
FCR7350R	RED
FCR7350G	GREEN
FCR7350L	BLUE
FCR7350Y	YELLOW

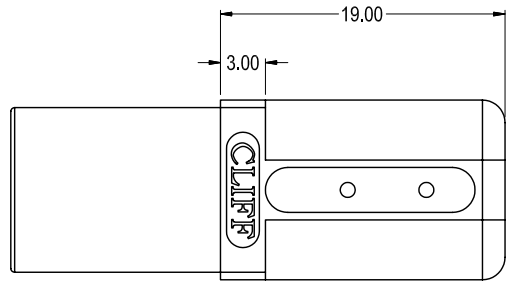

ISS.	AMEND	DATE
1	1st DRAWN	29/08/06
2	BORDER+RATINGS	03/09/10

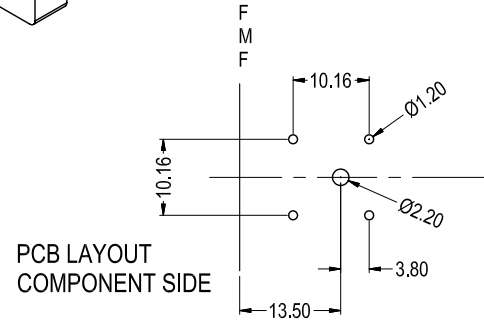
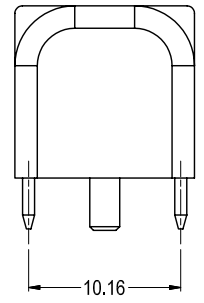
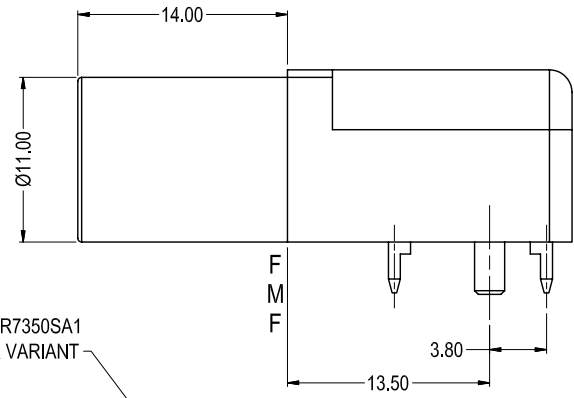
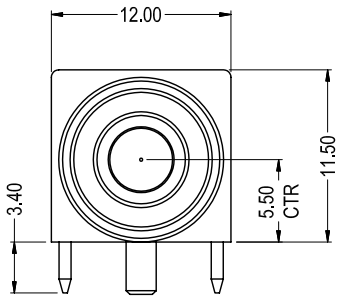

SEE FCR7350SA1 FOR COLOUR VARIANT

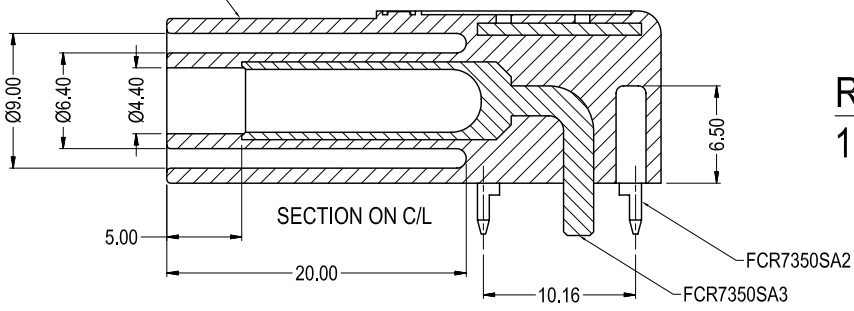

**RATED**  
1KV CAT III - 24A

**NOTES**

- 1) PART TO BE INSERT MOULDED WITH FCR7350SA2 AND FCR7350SA3
- 2) PARTS TO BE MADE TO CAD FILE SUPPLIED
- 3) PARTS TO BE FREE FROM FLASH AND SINK
- 4) FEED POINT TO BE AGREED
- 5) LOGO AND RATING TO BE ON INSERTS

**RoHS**  
COMPLIANT

**TOLERANCE**  
NO DEC. PLACE ±0.50  
1 DEC. PLACE ±0.20  
2 DEC. PLACE ±0.10  
HOLE Ø ±0.10  
ANGLES ±1/2°  
UNLESS OTHERWISE STATED

**Cliff Electronic Components Ltd.**  
76 Holmethorpe Avenue, Holmethorpe Industrial Estate,  
Redhill, Surrey, RH1 2PF, England, UK  
Tel: 01737-771375 Fax: 01737-766012 Website: www.cliffuk.co.uk

DIMENSIONS IN MILLIMETERS UNLESS OTHERWISE STATED. WORK TO DIMENSIONS. REMOVE ALL BURRS. IF IN DOUBT ASK.

3rd ANGLE PROJECTION:

DO NOT SCALE

MATERIAL: NYLON 6 / BRASS

TITLE: S16N - PC (COLOUR)

FINISH: AS MOULDED / GOLD PLATED

DRWG. No. **FCR7350** FORM: A4DRWGH

THE CONTENTS OF THIS DOCUMENT MUST NOT BE COPIED OR DISCLOSED TO A 3rd PARTY WITHOUT WRITTEN PERMISSION OF CLIFF UK. © 2006

DRAWN: T.J.O.

APPROVED: D.P.J.