



PART NO.

698 Series

REVISIONS

ECN #	REV	DESCRIPTION	DRAWN	DATE	CHECKD	DATE	APPRVD	DATE
-	A	RELEASED	Suresh	30/5/05	shashi	30/5/05	NK	10/6/05

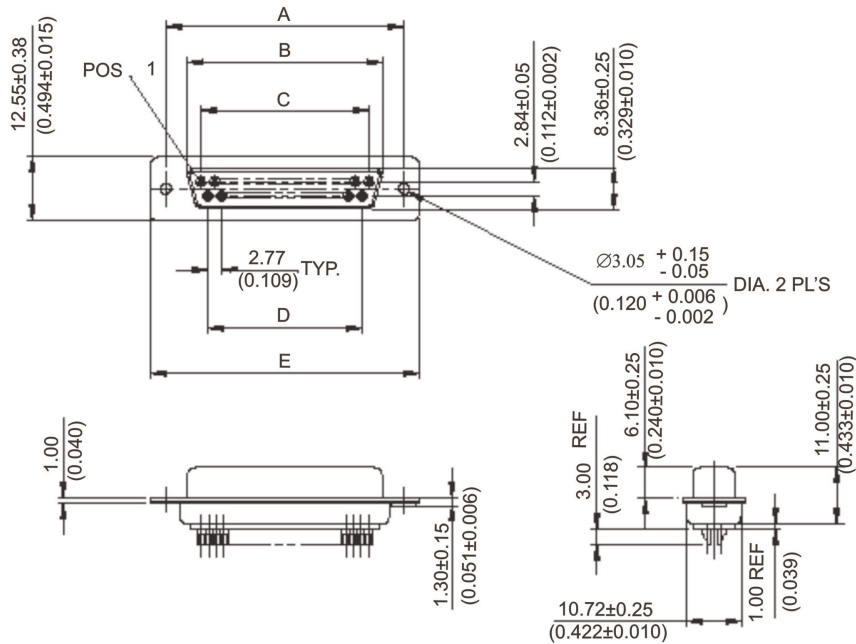

Features:

- Tin and Dimple Shells.
- Nickel plated solder buckets.
- Gold plated formed contacts.
- Glass filled P.B.T insulators.

Specifications:

Current Rating	: 5Amps at 25°C.
Insulation Resistance	: 5000MΩ minimum at 500Vdc.
Dielectric Withstanding Voltage	: AC 1000V minimum (for 1minute).
Contact Resistance	: 15mΩ maximum mated.
Operating Temperature	: -55°C to +105°C.
Insulator Material	: PBT and Glass-Fibre reinforced.
Contact Material	: Brass, Gold over Nickel in contact area. Tin plated solder cup.
Shell	: Steel, Tin plated.
Working Voltage	: 250Vrms.

Specification Table

Number of Ways	Types	A ±0.13 (0.005)	B ±0.25 (0.010)	C ±0.13 (0.005)	D ±0.13 (0.005)	E ±0.38 (0.015)	F ±0.25 (0.010)	Order Multiple	Part Number
09	Plug	-	-	-	-	-	-	5	698064
15	Plug	-	-	-	-	-	-	5	698076
25	Plug	-	-	-	-	-	-	5	698088
37	Plug	-	-	-	-	-	-	5	698090
09	Socket	24.99 (0.984)	16.33 (0.643)	11.08 (0.436)	8.31 (0.327)	30.89 (1.216)	19.28 (0.759)	5	698106
15	Socket	33.32 (1.312)	24.66 (0.971)	19.39 (0.763)	16.62 (0.654)	39.10 (1.539)	27.51 (1.083)	5	698118
25	Socket	47.04 (1.852)	38.38 (1.511)	33.24 (1.309)	30.47 (1.200)	53.09 (2.090)	41.30 (1.625)	5	698120
37	Socket	63.05 (2.500)	54.84 (2.159)	49.86 (1.963)	47.09 (1.854)	69.40 (2.732)	57.71 (2.272)	1	698131

Dimensions : Millimetres (Inches)

This data sheet and its contents (the "Information") belong to the Premier Farnell Group (the "Group") or are licensed to it. No licence is granted for the use of it other than for information purposes in connection with the products to which it relates. No licence of any intellectual property rights is granted. The Information is subject to change without notice and replaces all data sheets previously supplied. The Information supplied is believed to be accurate but the Group assumes no responsibility for its accuracy or completeness, any error in or omission from it or for any use made of it. Users of this data sheet should check for themselves the Information and the suitability of the products for their purpose and not make any assumptions based on information included or omitted. Liability for loss or damage resulting from any reliance on the Information or use of it (including liability resulting from negligence or where the Group was aware of the possibility of such loss or damage arising) is excluded. This will not operate to limit or restrict the Group's liability for death or personal injury resulting from its negligence. MULTICOMP is the registered trademark of the Group. © Premier Farnell plc 2004.

TOLERANCES:
UNLESS OTHERWISE SPECIFIED, DIMENSIONS ARE FOR REFERENCE PURPOSES ONLY.

DRAWN BY:	DATE:
Suresh	30/05/05
CHECKED BY:	DATE:
shashi	30/05/05
APPROVED BY:	DATE:
NK	10/06/05

DRAWING TITLE:			
Solder Bucket 'D' Connectors - EMI/RFI Shielded			
SIZE	DWG NO.	ELECTRONIC FILE	REV
A	M100000011	43099_DWG	
SCALE: NTS		U.O.M.: mm (Inches)	SHEET: 1 OF 2



PART NO.

698 Series

REVISIONS

ECN #	REV	DESCRIPTION	DRAWN	DATE	CHECKD	DATE	APPRVD	DATE
-	A	RELEASED	Suresh	30/5/05	shashi	30/5/05	NK	10/6/05

Notes:

International Sales Offices:

AUSTRALIA - Farnell InOne Tel No: ++ 61 2 9645 8888 Fax No: ++ 61 2 9644 7898	GERMANY - Farnell InOne Tel No: ++ 49 89 61 39 39 39 Fax No: ++ 49 89 613 59 01	SINGAPORE - Farnell-Newark InOne Tel No: ++ 65 6788 0200 Fax No: ++ 65 6788 0300
AUSTRIA - Farnell InOne Tel No: ++ 43 662 2180 680 Fax No: ++ 43 662 2180 670	HONG KONG - Farnell-Newark InOne Tel No: ++ 852 2268 9888 Fax No: ++ 852 2268 9899	SPAIN - Farnell InOne Tel No: ++ 34 93 475 8805 Fax No: ++ 34 93 474 5107
BELGIUM - Farnell InOne Tel No: ++ 32 3 475 2810 Fax No: ++ 32 3 227 3648	IRELAND - Farnell InOne Tel No: ++ 353 1 830 9277 Fax No: ++ 353 1 830 9016	SWEDEN - Farnell InOne Tel No: ++ 46 8 730 50 00 Fax No: ++ 46 8 83 52 62
BRAZIL - Farnell-Newark InOne Tel No: ++ 55 11 4066 9400 Fax No: ++ 55 11 4066 9410	ITALY - Farnell InOne Tel No: ++ 39 02 93 995 200 Fax No: ++ 39 02 93 995 300	SWITZERLAND - Farnell InOne Tel No: ++ 41 1 204 64 64 Fax No: ++ 41 1 204 64 54
CHINA - Farnell-Newark InOne Tel No: ++86 10 6238 5152 Fax No: ++86 10 6238 5022	MALAYSIA - Farnell-Newark InOne Tel No: ++ 60 3 7873 8000 Fax No: ++ 60 3 7873 7000	UK - Farnell InOne Tel No: ++ 44 8701 200 200 Fax No: ++ 44 8701 200 201
DENMARK - Farnell InOne Tel No: ++ 45 44 53 66 44 Fax No: ++ 45 44 53 66 06	NETHERLANDS - Farnell InOne Tel No: ++ 31 30 241 7373 Fax No: ++ 31 30 241 7333	UK - BuckHickman InOne ++ 44 8450 510 150 ++ 44 8450 510 130
ESTONIA - Farnell InOne Tel No: ++ 358 9 560 7780 Fax No: ++ 358 9 345 5411	NEW ZEALAND - Farnell InOne Tel No: ++ 64 9 357 0646 Fax No: ++ 64 9 357 0656	UK - CPC ++ 44 8701 202 530 ++ 44 8701 202 531
FINLAND - Farnell InOne Tel No: ++ 358 9 560 7780 Fax No: ++ 358 9 345 5411	NORWAY - Farnell InOne Tel No: ++ 45 44 53 66 66 Fax No: ++ 45 44 53 66 02	
FRANCE - Farnell InOne Tel No: ++ 33 474 68 99 99 Fax No: ++ 33 474 68 99 90	PORTUGAL - Farnell InOne Tel No: ++ 34 93 475 8804 Fax No: ++ 34 93 474 5288	

export EXPORT - Farnell InOne
Tel No: ++ 44 8701 200 208
Fax No: ++ 44 8701 200 209
For enquiries from all other markets

<http://www.farnellinone.com>
<http://www.buckhickmaninone.com>
<http://www.cpc.co.uk>

This data sheet and its contents (the "Information") belong to the Premier Farnell Group (the "Group") or are licensed to it. No licence is granted for the use of it other than for information purposes in connection with the products to which it relates. No licence of any intellectual property rights is granted. The Information is subject to change without notice and replaces all data sheets previously supplied. The Information supplied is believed to be accurate but the Group assumes no responsibility for its accuracy or completeness, any error in or omission from it or for any use made of it. Users of this data sheet should check for themselves the Information and the suitability of the products for their purpose and not make any assumptions based on information included or omitted. Liability for loss or damage resulting from any reliance on the Information or use of it (including liability resulting from negligence or where the Group was aware of the possibility of such loss or damage arising) is excluded. This will not operate to limit or restrict the Group's liability for death or personal injury resulting from its negligence. MULTICOMP is the registered trademark of the Group. © Premier Farnell plc 2004.

TOLERANCES:
UNLESS OTHERWISE SPECIFIED, DIMENSIONS ARE FOR REFERENCE PURPOSES ONLY.

DRAWN BY:	DATE:
Suresh	30/05/05
CHECKED BY:	DATE:
shashi	30/05/05
APPROVED BY:	DATE:
NK	10/06/05

DRAWING TITLE:			
Solder Bucket 'D' Connectors - EMI/RFI Shielded			
SIZE	DWG NO.	ELECTRONIC FILE	REV
A	M100000011	43099_DWG	
SCALE: NTS		U.O.M.:	SHEET: 2 OF 2