

QTS-XXX-XX-XX-D-RA-WT-XXX

No OF POSITIONS
-025, -050, -075, -100
[PER ROW]
(SEE NOTE 5)

LEAD STYLE
-01: .062 BOARD
-02: .093 BOARD

PLATING SPECIFICATION
(SEE TABLE 3)

ROW SPECIFICATION
-D: DOUBLE (USE QTS-25-01-D-XX-RA)

OPTION

-LS1: LOCKING SCREW
(FOR MATING WITH QSS...-RA...-LS1)
(USE WITH SP-18-01-TM SOLDER PIN)
(SEE FIG. 2, SHT 3) (SEE NOTE 11)

-LS2: LOCKING SCREW
(FOR MATING WITH QSS...-LS2)
(USE WITH SP-18-01-TM SOLDER PIN)
(SEE FIG. 3, SHT 3) (SEE NOTE 11)

-P: PICK AND PLACE PAD
(USE PPP-63) (SEE FIG. 4, SHT 4)

-SP: SOLDER PIN
(NOT AVAILABLE W/ LSX OPTIONS)
(USE SP-19-T) (SEE FIG. 5, SHT 4)

-WT: WELD TAB
(SEE NOTE 5) (USE WT-16-XX-T) **AF**

-RA: RIGHT ANGLE

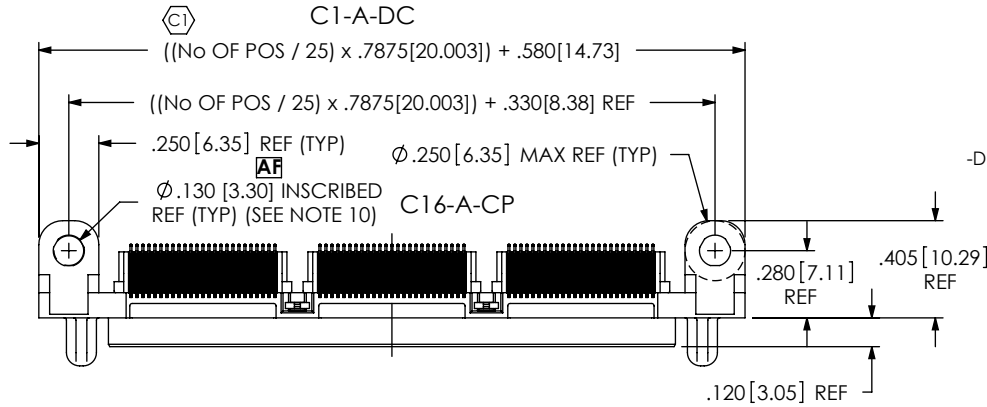

DO NOT SCALE FROM THIS PRINT

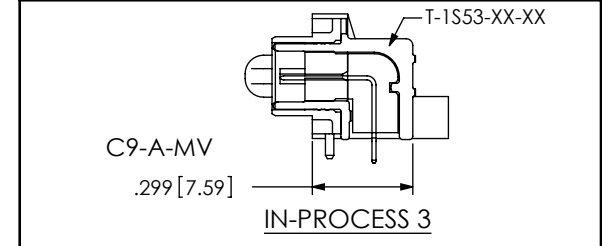
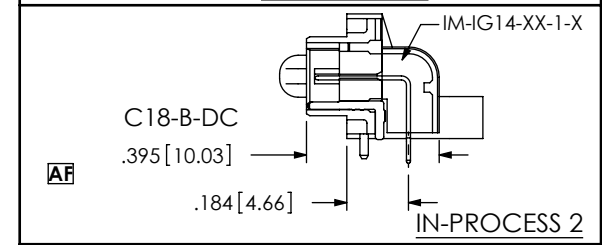
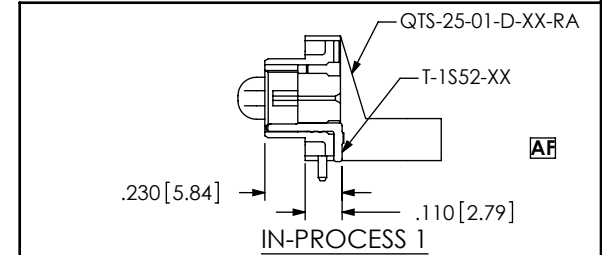
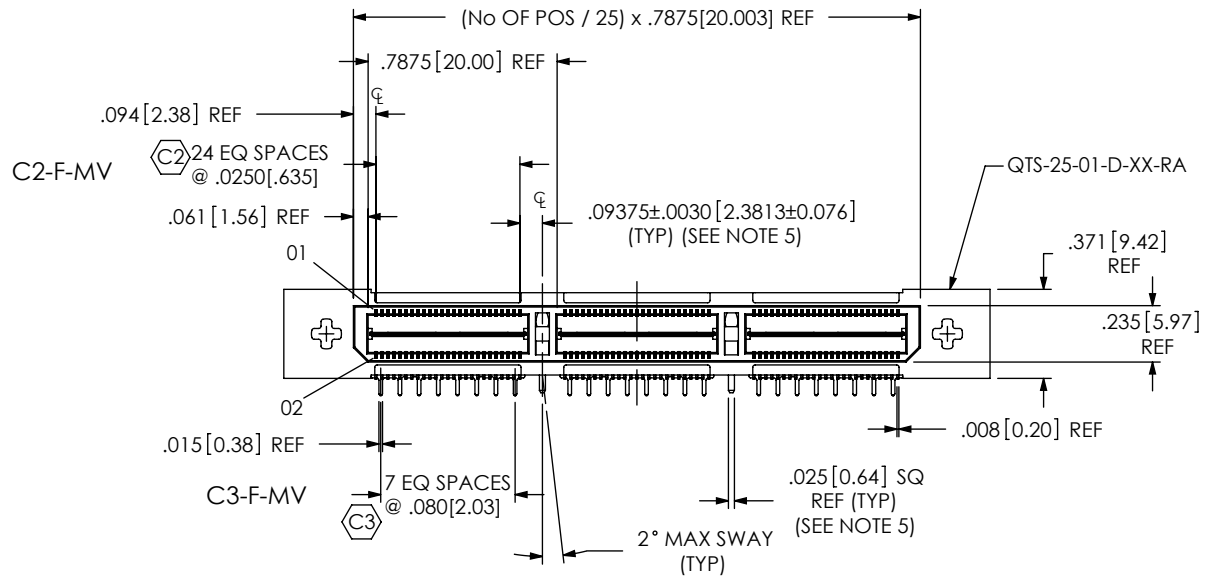

- NOTES:
1. **C1** REPRESENTS A CRITICAL DIMENSION.
 2. BURR ALLOWANCE: .0010 MAX.
 3. MINIMUM PUSHOUT FORCE: 5 OZ.
 4. NOTE DELETED.
 5. WELD TABS NOT AVAILABLE ON -025 POSITION.
 6. TIPS OF TERMINALS MAY NOT EXTEND BEYOND THIS SURFACE.
 7. IF NEEDED, -L PLATING CAN BE SUBSTITUTED FOR -F PLATING.
 8. DESIGNED FOR USE WITH A .062 OR .093 THICK PCB.
 9. PACKAGE IN TRAYS AS STANDARD.
 10. RECOMMENDED TORQUE ON HOLD DOWN SCREWS TO BE 20 IN-OZ +/- 5 IN-OZ
 11. MAX TORQUE ON STS-02 TO BE 20 IN-OZ.
- FIG. 1
QTS-075-01-X-D-RA-WT SHOWN

UNLESS OTHERWISE SPECIFIED, DIMENSIONS ARE IN INCHES. TOLERANCES ARE:
DECIMALS ANGLES
.XX: $\pm .01$ [.3] 2°
.XXX: $\pm .005$ [.13]
.XXXX: $\pm .0020$ [.051]

PROPRIETARY NOTE
THIS DOCUMENT CONTAINS INFORMATION CONFIDENTIAL AND PROPRIETARY TO SAMTEC, INC. AND SHALL NOT BE REPRODUCED OR TRANSFERRED TO OTHER DOCUMENTS OR DISCLOSED TO OTHERS OR USED FOR ANY PURPOSE OTHER THAN THAT WHICH IT WAS OBTAINED WITHOUT THE EXPRESSED WRITTEN CONSENT OF SAMTEC, INC.



520 PARK EAST BLVD. NEW ALBANY, IN 47150
PHONE: 812-944-6733 FAX: 812-948-5047
e-Mail: info@SAMTEC.com code: 55322

MATERIAL: DO NOT SCALE DRAWING SHEET SCALE: 1:0.8
INSULATOR: LCP, COLOR: BLACK
TERMINAL, WELD TAB & GROUND PLANE: PHOS BRONZE
SCREW: STEEL

DESCRIPTION: .635mm DOUBLE ROW RIGHT ANGLE TERMINAL STRIP
DWG. NO. QTS-XXX-XX-XX-D-RA-WT-XXX
BY: KEVIN B 08/03/01 SHEET 1 OF 4

TABLE 2				
LEAD STYLE	"A"	"B"	IM-1G14-XX-1-X	WT-16-XX-T
-01	.060[1.52]	.068[1.73]	IM-1G14-01-1-XX	WT-16-01-T
-02	.125[3.18]	.125[3.18]	IM-1G14-02-1-XX	WT-16-02-T

AF

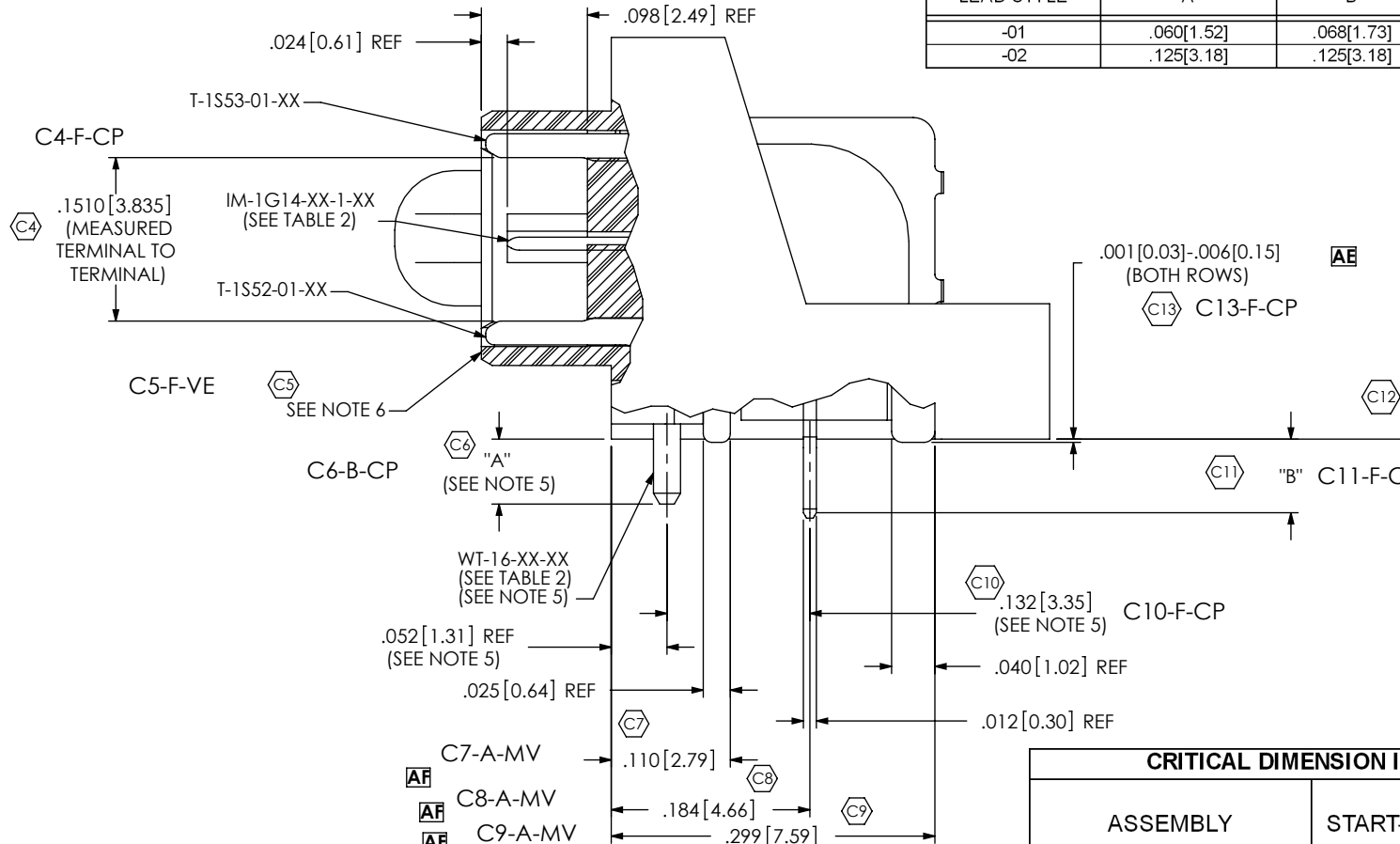



TABLE 1	
No OF POSITIONS	COPLANARITY
-025 THRU -075	.004[.10]
-100	.006[.15]

CRITICAL DIMENSION INSPECTION INSTRUCTION TABLE		
ASSEMBLY OPERATION	START-UP INSPECTION INSPECT CODE A	IN-PROCESS INSPECTION INSPECT CODE B
FILL T-1S52-XX	C1, C16	C7
FILL IM-1G14-XX-1-X	C1, C16, C7	C8, C18
FILL T-1S53-XX-XX	C1, C16, C7, C8, C18	C9
FILL WT-16-XX-XX	C1, C16, C7, C8, C18, C9	C6
SP	C1, C9, C16, C18	C15
LS1	C1, C9, C16, C18	C15, C19
LS2	C1, C9, C16, C18	C15
P	C1, C9, C16, C18	C20

TABLE 3: PLATING SPECIFICATIONS (SEE NOTE 7)			
	CONTACT	CONTACT	GROUND PLANE
-F	T-1S52-01-F FLASH GOLD CONTACT, MATTE TIN TAIL	T-1S53-01-F FLASH GOLD CONTACT, MATTE TIN TAIL	IM-1G14-XX-F FLASH GOLD CONTACT, MATTE TIN TAIL
-L	T-1S52-01-L LIGHT GOLD CONTACT, MATTE TIN TAIL	T-1S53-01-L LIGHT GOLD CONTACT, MATTE TIN TAIL	IM-1G14-XX-L LIGHT GOLD CONTACT, MATTE TIN TAIL
-H	T-1S52-01-H HEAVY GOLD CONTACT, FLASH GOLD TAIL	T-1S53-01-H HEAVY GOLD CONTACT, FLASH GOLD TAIL	IM-1G14-XX-L LIGHT GOLD CONTACT, MATTE TIN TAIL

F:\DWG\MISC\VMKTG\QTS-XXX-XX-XX-D-RA-WT-XXX-MKT.SLDDRW

<p>PROPRIETARY NOTE</p> <p>THIS DOCUMENT CONTAINS INFORMATION CONFIDENTIAL AND PROPRIETARY TO SAMTEC, INC. AND SHALL NOT BE REPRODUCED OR TRANSFERRED TO OTHER DOCUMENTS OR DISCLOSED TO OTHERS OR USED FOR ANY PURPOSE OTHER THAN THAT WHICH IT WAS OBTAINED WITHOUT THE EXPRESSED WRITTEN CONSENT OF SAMTEC, INC.</p> <p>DO NOT SCALE DRAWING</p> <p>SHEET SCALE: 1:0.166667</p>	 <p>520 PARK EAST BLVD. NEW ALBANY, IN 47150 PHONE: 812-944-6733 FAX: 812-948-5047 e-Mail: info@SAMTEC.com code: 55322</p>	
	<p>DESCRIPTION: .635mm DOUBLE ROW RIGHT ANGLE TERMINAL STRIP</p>	
	<p>DWG. NO. QTS-XXX-XX-XX-D-RA-WT-XXX</p>	
	BY: KEVIN B 08/03/01	SHEET 2 OF 4

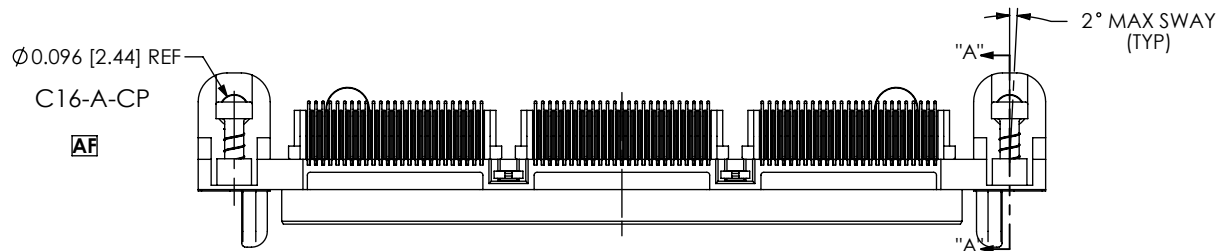
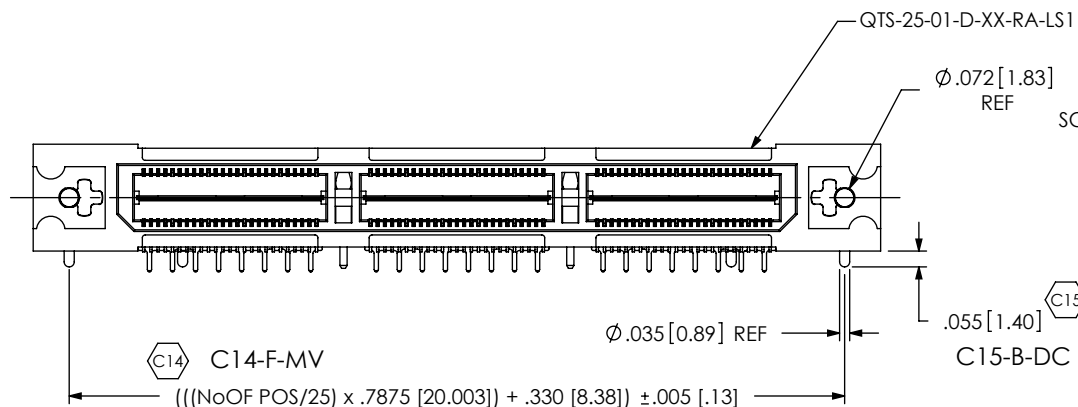
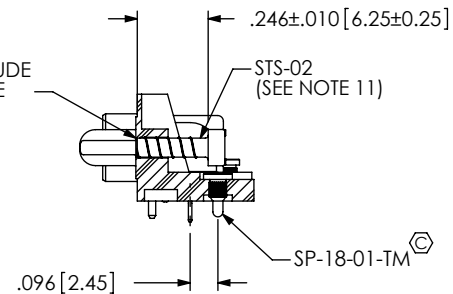

FIG. 2
 -LS1 OPTION
 (QTS-075-01-X-D-RA-WT-LS1 SHOWN)
 (SAME AS FIG. 1, EXCEPT AS SHOWN)
 (AVAILABLE ON -.01 LEADSTYLE ONLY)



AF
 C19-B-VE
 SCREW CANNOT PROTRUDE
 BEYOND THIS SURFACE



SECTION "A"- "A"

FIG. 3

-LS2 OPTION
 (QTS-075-01-X-D-RA-WT-LS2 SHOWN)
 (SAME AS FIG. 2, EXCEPT AS SHOWN)

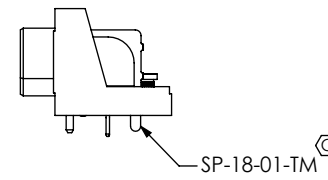
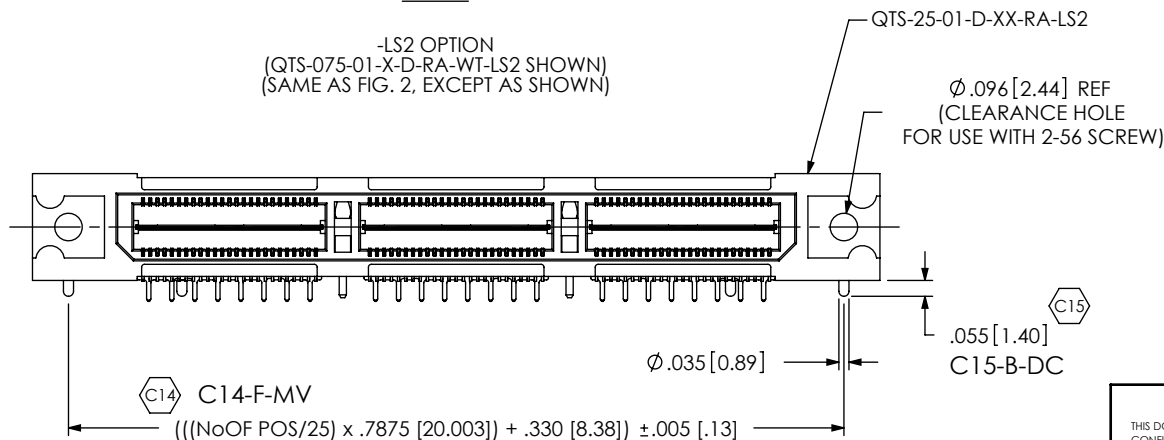

PROPRIETARY NOTE
 THIS DOCUMENT CONTAINS INFORMATION
 CONFIDENTIAL AND PROPRIETARY TO
 SAMTEC, INC. AND SHALL NOT BE REPRODUCED
 OR TRANSFERRED TO OTHER DOCUMENTS OR
 DISCLOSED TO OTHERS OR USED FOR ANY
 PURPOSE OTHER THAN THAT WHICH IT WAS
 OBTAINED WITHOUT THE EXPRESSED WRITTEN
 CONSENT OF SAMTEC, INC.

DO NOT SCALE DRAWING

SHEET SCALE: 1.5:1



520 PARK EAST BLVD, NEW ALBANY, IN 47150
 PHONE: 812-944-6733 FAX: 812-948-5047
 e-Mail: info@SAMTEC.com code: 55322

DESCRIPTION:
 .635mm DOUBLE ROW RIGHT ANGLE TERMINAL STRIP

DWG. NO.
QTS-XXX-XX-XX-D-RA-WT-XXX

BY: KEVIN B 08/03/01 SHEET 3 OF 4

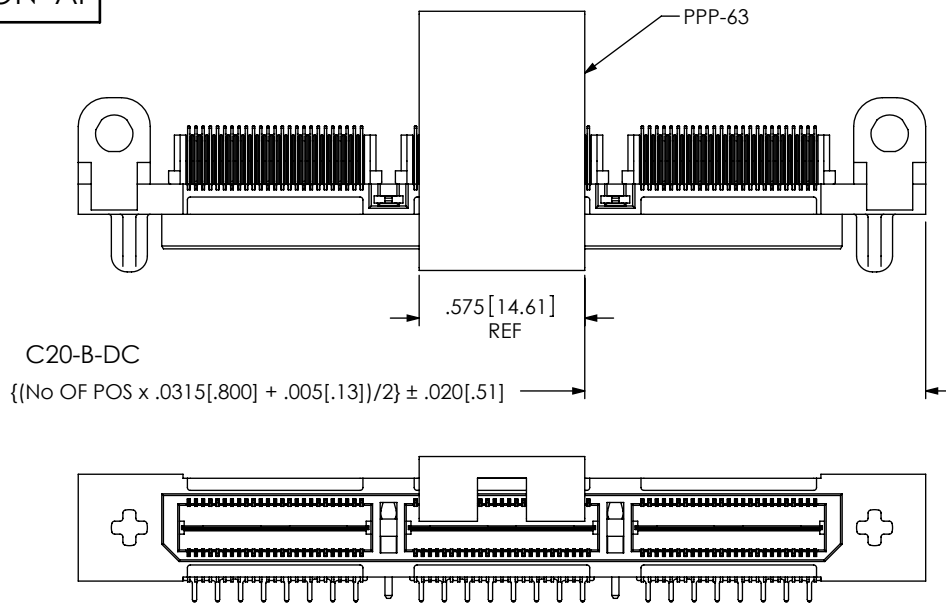

FIG. 4
-P OPTION
(QTS-075-01-X-D-RA-WT-P SHOWN)
(SAME AS FIG. 1, EXCEPT AS SHOWN)

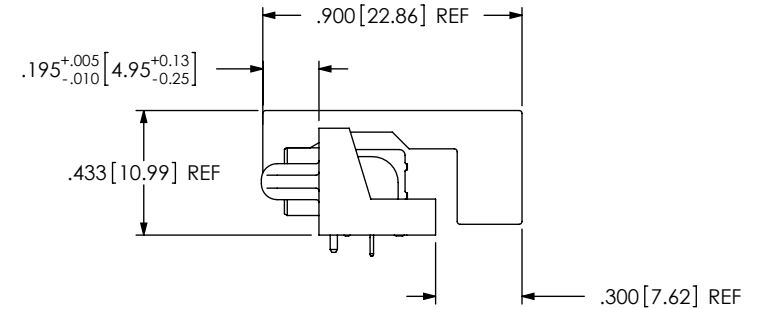
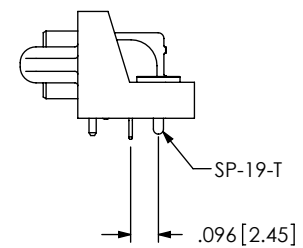
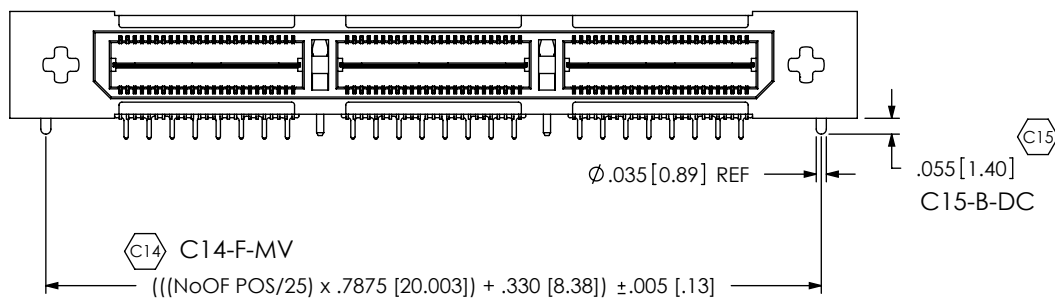

FIG. 5
-SP OPTION
(QTS-075-01-X-D-RA-WT-SP SHOWN)
(SAME AS FIG. 1, EXCEPT AS SHOWN)



PROPRIETARY NOTE
THIS DOCUMENT CONTAINS INFORMATION
CONFIDENTIAL AND PROPRIETARY TO
SAMTEC, INC. AND SHALL NOT BE REPRODUCED
OR TRANSFERRED TO OTHER DOCUMENTS OR
DISCLOSED TO OTHERS OR USED FOR ANY
PURPOSE OTHER THAN THAT WHICH IT WAS
OBTAINED WITHOUT THE EXPRESSED WRITTEN
CONSENT OF SAMTEC, INC.

DO NOT SCALE DRAWING

SHEET SCALE: 1.5:1

samtec

520 PARK EAST BLVD, NEW ALBANY, IN 47150
PHONE: 812-944-6733 FAX: 812-948-5047
e-Mail: info@SAMTEC.com code: 55322

DESCRIPTION:
.635mm DOUBLE ROW RIGHT ANGLE TERMINAL STRIP

DWG. NO.
QTS-XXX-XX-XX-D-RA-WT-XXX

BY: KEVIN B 08/03/01 SHEET 4 OF 4