

REV	A	0460-204-04* *	REVISIONS		
SYM			DESCRIPTION	DATE	APPROVED
NC			NEW RELEASE PER E.O. A6895	10/9/87	JA
A			REVISED & REDRAWN PER E.O. P17007	12-19-00	RDR

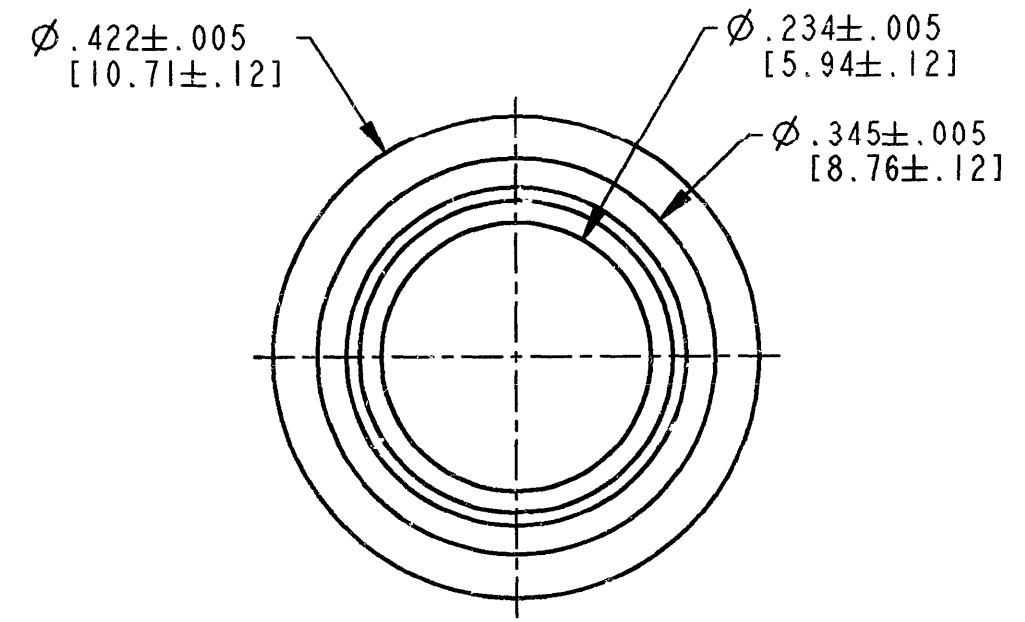
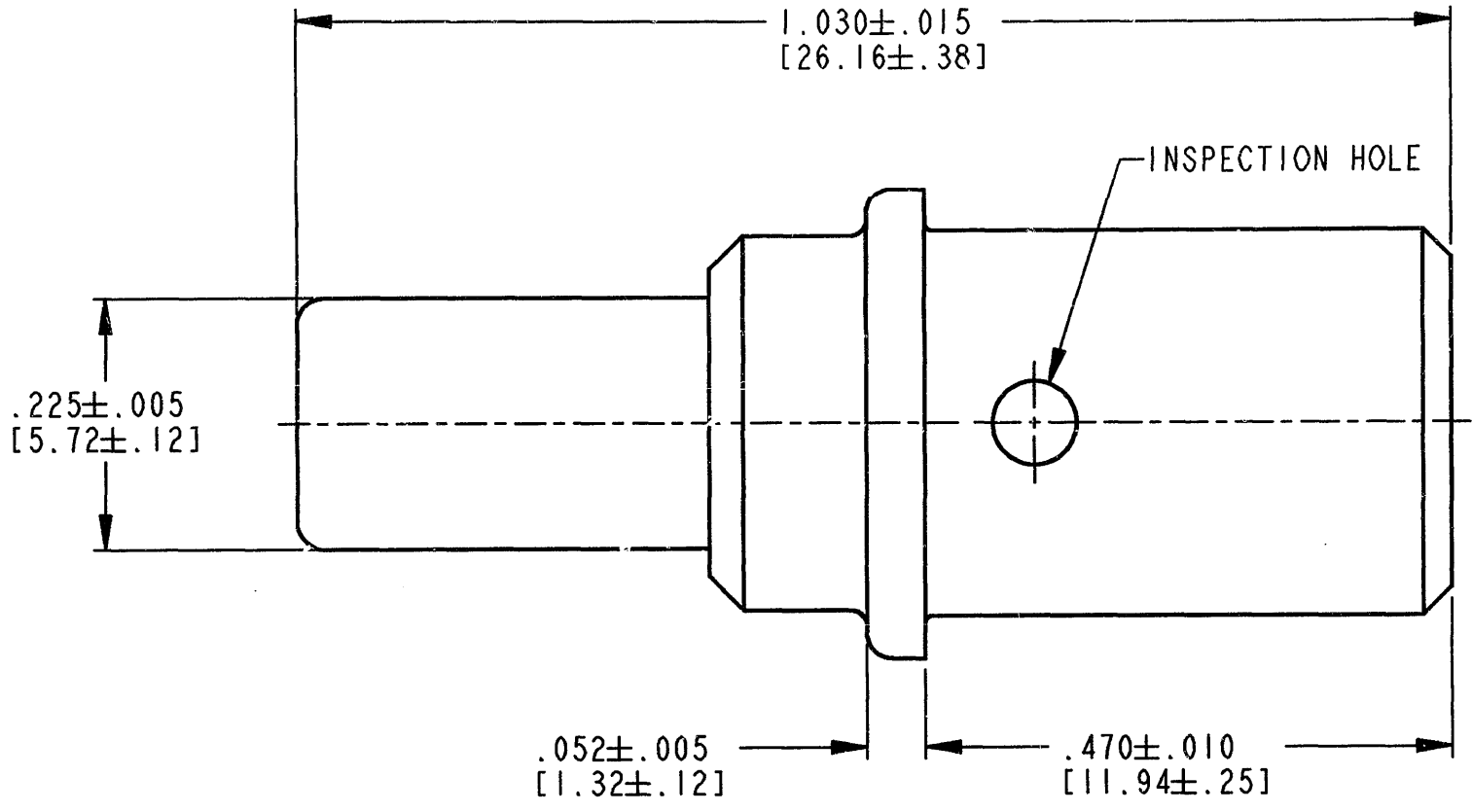

4. FOR CONTACT PERFORMANCE AND APPLICATION CHARACTERISTICS SEE DRAWING 0425-015-0000.
 3. THIS CONTACT MAY BE CRIMPED WITH HDP-400 POWER CRIMPER OR HDT-04-08 HAND TOOL. SEE DRAWING 0425-205-0000 FOR APPLICABLE WIRE SIZE AND CRIMP INFORMATION.
 2. WHEN ** = 90: PLATING IS NICKEL.
 1. DIMENSIONS ARE IN INCHES [mm].
- NOTES: UNLESS OTHERWISE SPECIFIED

SIGNATURE & DATE		CONTACT PIN SIZE 4	CP	MATL. CODE
DR	D. MEYER 11/29/00		The Deutch Company DEUTSCH I.P.D. 3850 INDUSTRIAL AVE. HEMET, CALIF. 92545	
CHK	B. B. Ford 12/18/00	ENVELOPE	B 0460-204-04* *	
PE	D. Meyer 12/13/00		DWG SIZE	CODE 11139
APPD	R. Reed 12-19-00			
SCALE	NONE	WT		