

BILL OF MATERIALS			
DET.	QTY.	DESCRIPTION	MATERIAL
1	1	SPRING	BeCu
2	1	HEX NUT	STEEL
3	1	LUG	.010 BRASS
4	1	BODY	BRASS

**FULL SECTION**

REVISIONS				
SYM	DESCRIPTION	REVISED BY	DATE	APPR

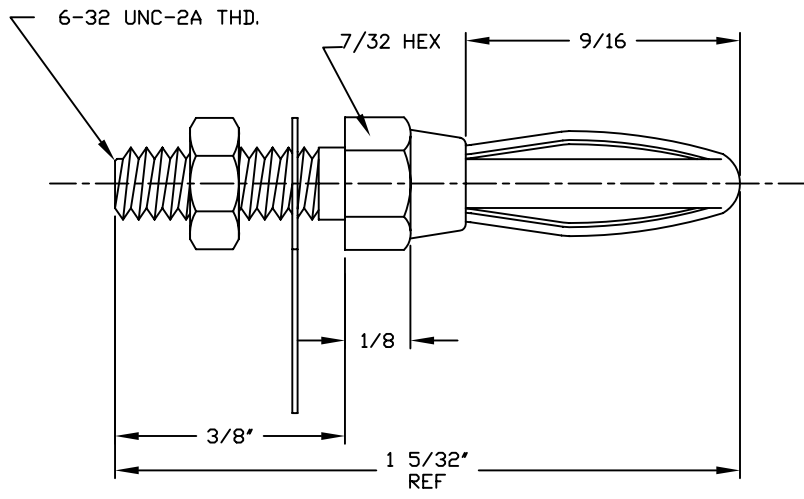
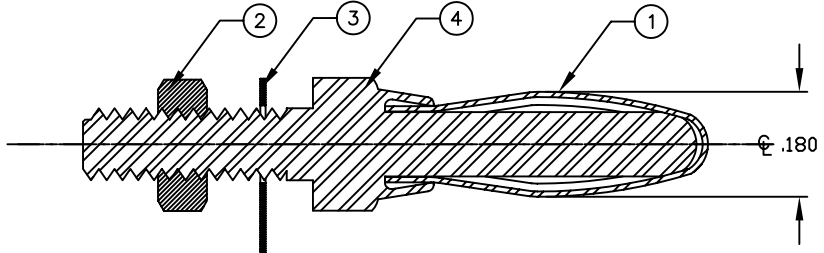

MATERIAL		"SEE TABLE"	FINISH		NICKEL		<b>ABBATRON</b> Electronic Connectors and Hardware 632 Arch Street, Meadville, Pa. 16335			
DIMENSIONAL TOLERANCES UNLESS OTHERWISE SPECIFIED			TITLE 401 BANANA PLUG ASSEMBLY							
.XX	.XXX	.XXXX								
----	----	----								
FRACTIONS		ANGLES	SCALE		DRAWN: S. GERHOLD DATE 8-1-95			SIZE	DRAWING NUMBER	ISSUE
----		----	4:1		CHECKED: E. MCKINNEY DATE 8-3-95			B	SD-401	E
HEAT TREAT		PLDT SCALE: 1:1			APPROVED: M. KLOECKER DATE 8-4-95					