

THIS COPY IS PROVIDED ON A RESTRICTED BASIS AND IS NOT TO BE USED IN ANY WAY DETRIMENTAL TO THE INTERESTS OF PANDUIT CORP.

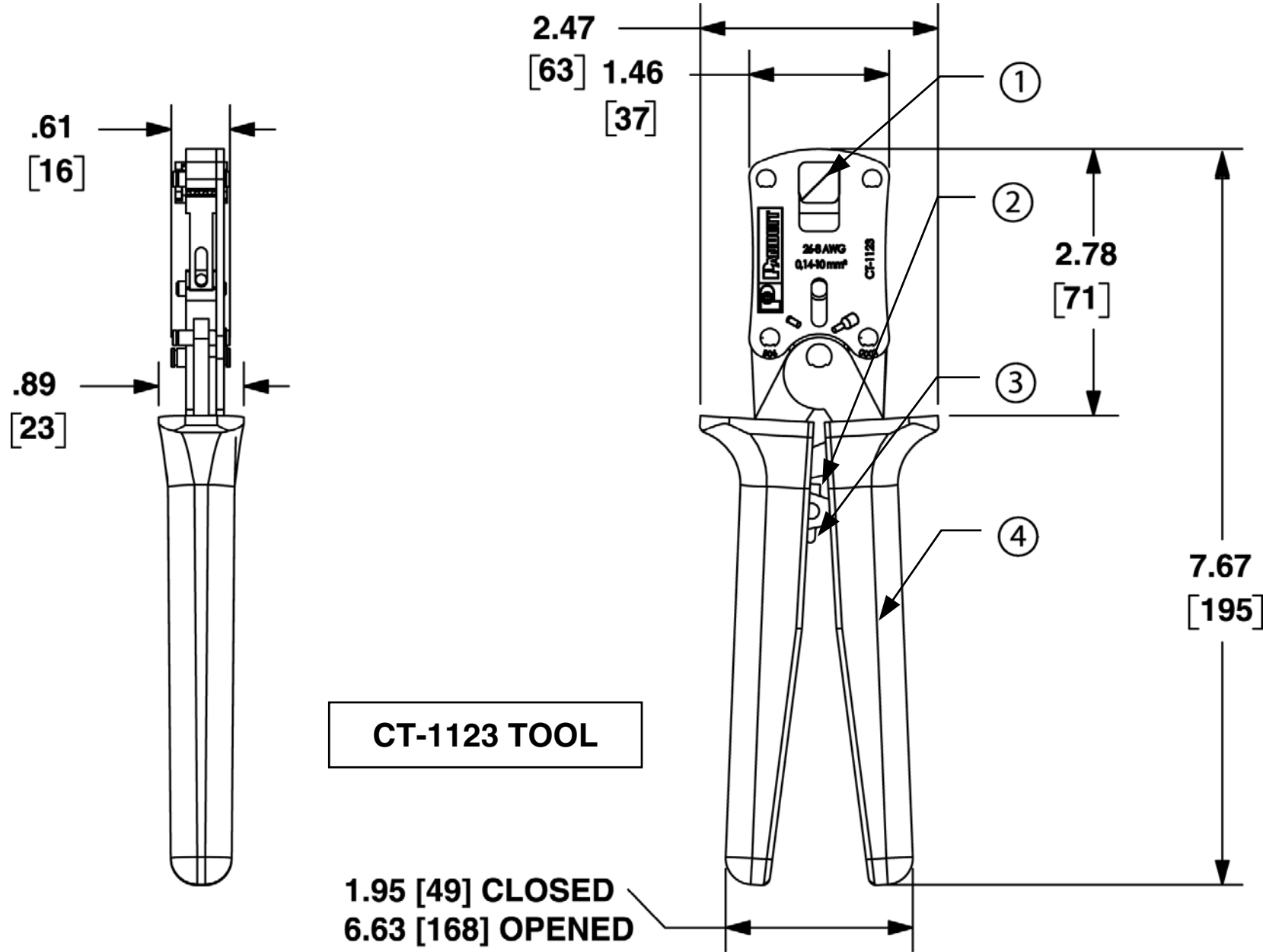

**NOTES, UNLESS OTHERWISE SPECIFIED:**

*PANDUIT* Tool Number CT-1123 is used to install single and dual wire *PANDUIT* insulated and non-insulated loose piece ferrules.

**Crimps the following types:**

- FTD type: 2 x 22 [.50mm<sup>2</sup>] to 2 x 12 [4.0mm<sup>2</sup>] AWG insulated ferrules
- FSD and FSF type: #26 [.14mm<sup>2</sup>] – #8 [10.0mm<sup>2</sup>] AWG insulated ferrules
- F type: #22 [.50mm<sup>2</sup>] – #16 [1.5mm<sup>2</sup>] AWG; and #12 [4.0mm<sup>2</sup>] – #8 [10.0mm<sup>2</sup>] AWG non-insulated ferrules

**TOOL FEATURES INCLUDE:**

1. Self-adjusting crimp die for Insulated and non-insulated ferrules. Ferrule size dependent on wire gage. Refer to ferrule packaging for proper ferrule and wire combinations.
2. Controlled cycle mechanism prevents tool from opening before crimp cycle is complete.
3. Manual release lever, push forward in the event that controlled cycle mechanism must be released.
4. Resilient grips to prevent operator fatigue.  
*NOTE: The grips are NOT intended to insulate against electrical shock.*

**TOOL WEIGHT:** 10.6 oz. (300 gr.)

**DIMENSIONS SHOWN IN PARENTHESES ARE MILLIMETERS.**

F:\wrkgrp\rvusers\ENGR DOCS - NEWCUSTOMER DRAWINGS\TP25123B01\_00 CT-1123 CD.doc

										<b>PANDUIT</b> CORP. TINLEY PARK, ILLINOIS				
										<b>CT-1123</b>				
										<b>CUSTOMER DRAWING</b>				
										UNLESS OTHERWISE SPECIFIED, DIMENSIONAL TOLERANCES ARE: (.x) ± ---- (.xxx) ± ---- (.xx) ± ---- ANGLES ± ----		UNLESS OTHERWISE SPECIFIED, ALL DIMENSIONS ARE GIVEN IN INCHES, THIRD ANGLE PROJECTION.		
										DRAWN BY: <b>BLR</b>	MATL:	SCALE <b>NONE</b>		
										DATE: <b>3-29-06</b>	<b>SEE NOTES</b>		DRAWING NO. <b>TP25123B01</b>	DWG <b>B</b> SIZE
										CHK'D: <b>SRRE</b>				
<b>00</b>	<b>3-29-06</b>	<b>BLR</b>	<b>SRRE</b>	<b>RELEASED</b>	<b>4195</b>	<b>---</b>	<b>RFL</b>							
<b>REV</b>	<b>DATE</b>	<b>BY</b>	<b>CHK'D</b>	<b>DESCRIPTION</b>	<b>ECN</b>	<b>- R</b>	<b>CUST</b>	<b>SUP</b>						