

MATERIAL NO.	ENGINEERING NO.	LENGTH
1300150137	3R9006A20A120	12' +.75-0 [305mm +19.0-0]
1300150140	3R9006A20F030	3'0" +1.75-0 [.9M +44.5-0]
1300150143	3R9006A20F060	6'0" +2.19-0 [1.8M +55.6-0]

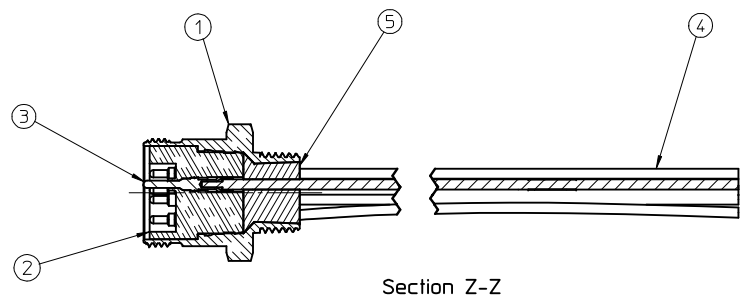
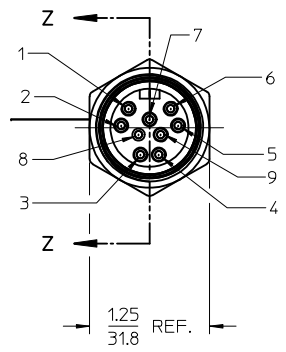
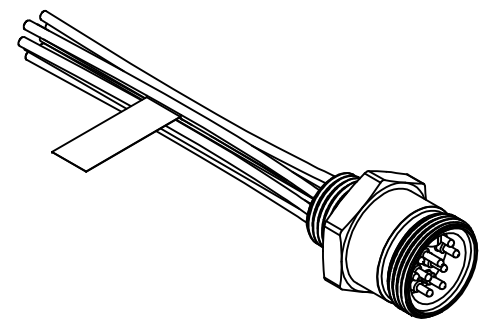
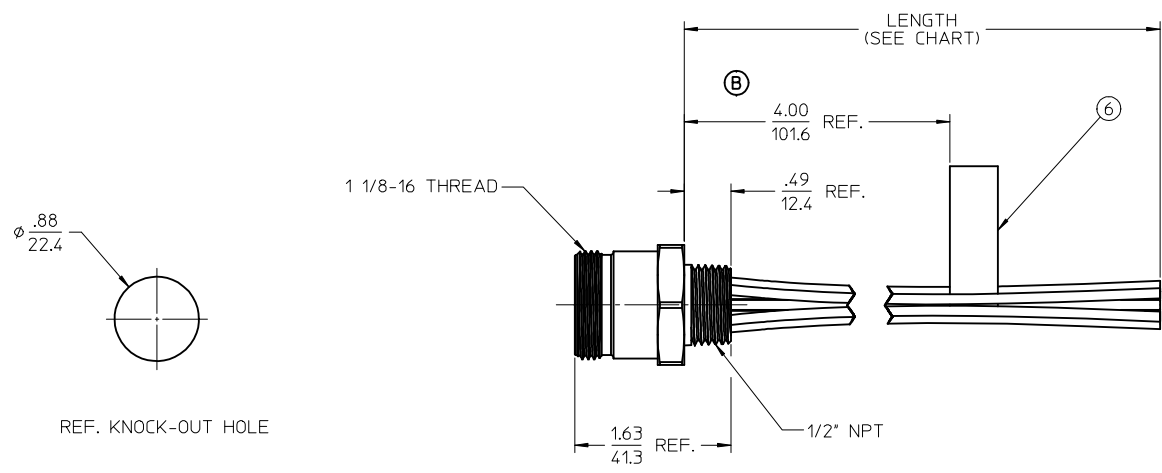

- NOTES:
1. MATERIAL: SEE TABLE
 2. FINISHES: SEE TABLE
 3. MATES WITH: NONE
 4. ELECTRICAL SPECIFICATIONS:
VOLTAGE RATING: 600V AC/DC
CURRENT RATING: 7 AMPS
 5. RoHS COMPLIANT

1	ORANGE
2	BLUE
3	RED-BLACK
4	GREEN-BLACK
5	WHITE
6	RED
7	GREEN-YELLOW
8	WHITE-BLACK
9	BLACK

WIRING DIAGRAM

ITEM	QTY.	DESCRIPTION	MATERIAL	FINISH
6	1	LABEL	PLASTIC FILM	BLACK/YELLOW
5	1	POTTING	EPOXY	
4	9	WIRE, 16 AWG (UL 1015)	PVC INSULATED	SEE WIRE DIAGRAM
3	9	CONTACT PIN	BRASS	GOLD PLATED
2	1	INSERT	PVC	YELLOW
1	1	RECEPCTACLE SHELL	ZINC ALLOY	E-COAT, BLACK

DIM WAS 8.00
 EC NO: MNA2010-0101
 DRAWN BY: DRWINRSTONE 2009/08/17
 CHKD BY: WOODMAN
 APPR: J. MURPHY 2009/08/21

QUALITY SYMBOLS
 ▽=0
 ▽=0
 GENERAL TOLERANCES (UNLESS SPECIFIED)
 4 PLACES ± --- ± ---
 3 PLACES ± --- ± ---
 2 PLACES ± --- ± .01
 1 PLACE ± 0.3 ± ---
 ANGULAR ± 1/2°
 DRAFT WHERE APPLICABLE
 MUST REMAIN
 WITHIN DIMENSIONS

DIMENSION STYLE
 IN/MM
 DRAWN BY: R. STONE
 DATE: 2009/03/26
 CHECKED BY: B. WOODMAN
 DATE: 2009/03/27
 APPROVED BY: J. MURPHY
 DATE: 2009/03/31
 MATERIAL NO.
SEE CHART
 SIZE: C

SCALE: 1:1
 DESIGN UNITS: INCH
 THIRD ANGLE PROJECTION
 TITLE: MC RECEPTACLE, MALE 9 POLE, 1/2" NPT
 MOLEX INCORPORATED
 DOCUMENT NO.: SD-130015-003
 SHEET NO.: 1 OF 1
 THIS DRAWING CONTAINS INFORMATION THAT IS PROPRIETARY TO MOLEX INCORPORATED AND SHOULD NOT BE USED WITHOUT WRITTEN PERMISSION