

DRAWING FOR QUOTATION PURPOSES ONLY. NOT TO BE WORKED TO.

ISSUE: 2  
BY: AJ  
RN: 6633  
DATE: 17-03-2011

DESCRIPTION OF LAST CHANGE:  
**RELEASED TO PRODUCTION**

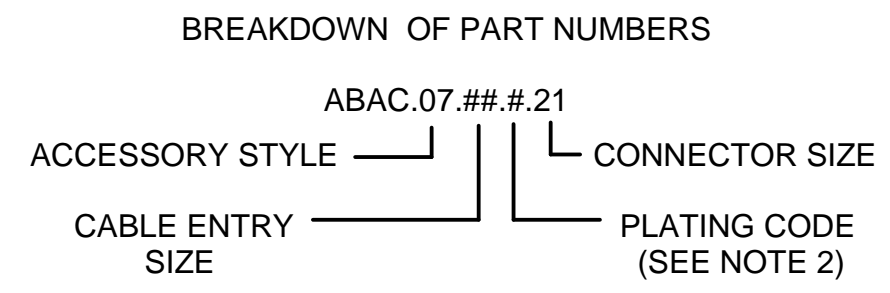
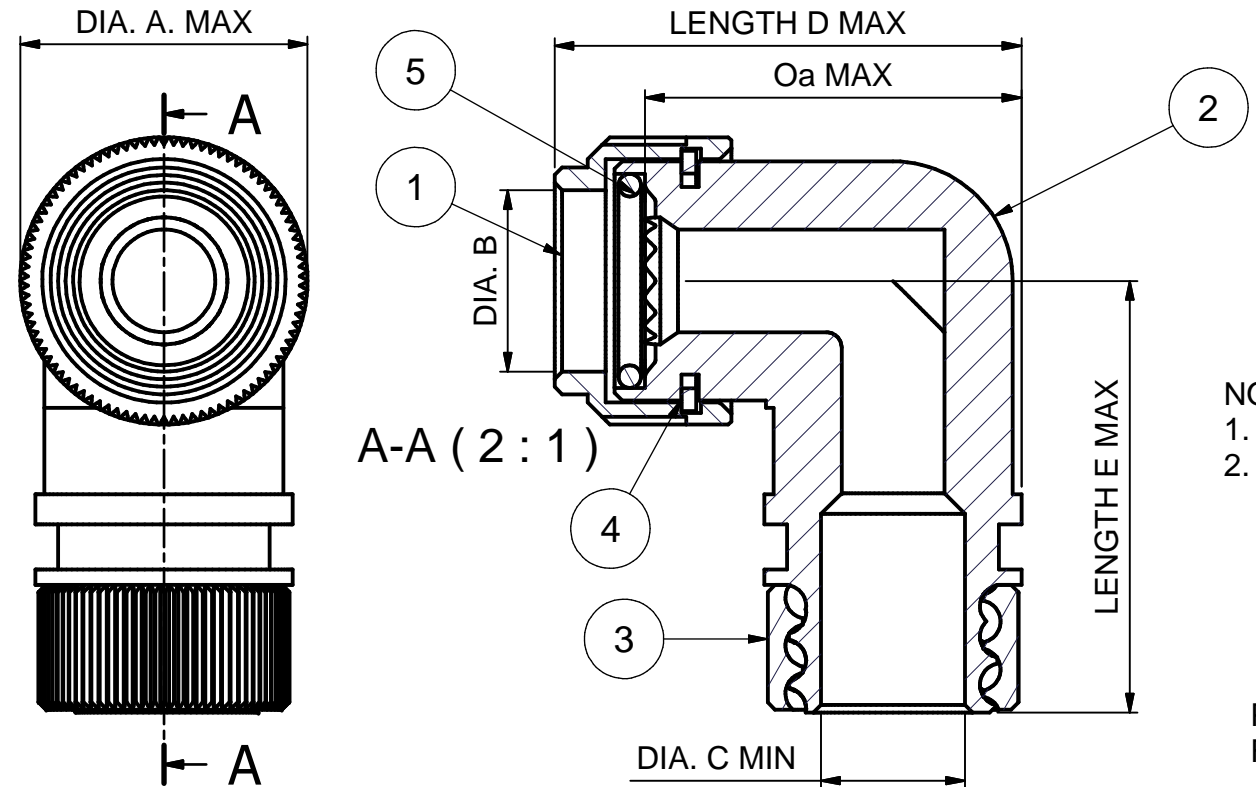

**NOTES.**

1. PART NUMBER TO BE MARKED HERE .

2. **ITEM 1, ITEM 2 AND ITEM 3** ARE TO BE USED FOR PLATING CODE:-  
W= OLIVE DRAB CADMIUM PLATE  
Q= ZINC COBALT OLIVE DRAB PASSIVATE  
QB= ZINC COBALT BLACK PASSIVATE

**ITEM 1A, ITEM 2A AND ITEM 3A** ARE TO BE USED FOR PLATED CODE:-  
F= ELECTROLESS NICKEL

CABLE SIZE	ASSY. NUMBER	ITEM 1 QTY 1	ITEM 1A QTY 1	ITEM 2 QTY 1	ITEM 2A QTY 1	ITEM 3 QTY 1	ITEM 3A QTY 1	ITEM 4 QTY 1	ITEM 5 QTY 1	DIA. A MAX	DIA. B	DIA. C MIN	LENGTH D MAX	LENGTH E MAX	Oa MAX
03	ABAC.07.03.#.21			514.2.00736.#.03	514.2.00726.4.03	514.2.18929.#.03	514.2.00719.4.03						4.70	32.79	26.41
04	ABAC.07.04.#.21			514.2.00736.#.04	514.2.00726.4.04	514.2.18929.#.04	514.2.00719.4.04						6.30	32.79	26.41
05	ABAC.07.05.#.21			514.2.00736.#.05	514.2.00726.4.05	514.2.18929.#.05	514.2.00719.4.05						7.90	33.57	27.19
06	ABAC.07.06.#.21			514.2.00736.#.06	514.2.00726.4.06	514.2.18929.#.06	514.2.00719.4.06						9.50	35.22	28.84
07	ABAC.07.07.#.21			514.2.00736.#.07	514.2.00726.4.07	514.2.18929.#.07	514.2.00719.4.07						11.10	36.76	30.38
08	ABAC.07.08.#.21			514.2.00736.#.08	514.2.00726.4.08	514.2.18929.#.08	514.2.00719.4.08						12.70	38.36	31.98
09	ABAC.07.09.#.21			514.2.00736.#.09	514.2.00726.4.09	514.2.18929.#.09	514.2.00719.4.09						14.20	39.94	33.56
10	ABAC.07.10.#.21			514.2.00736.#.10	514.2.00726.4.10	514.2.18929.#.10	514.2.00719.4.10						15.80	41.55	35.17
11	ABAC.07.11.#.21			514.2.00736.#.11	514.2.00726.4.11	514.2.18929.#.11	514.2.00719.4.11						17.40	43.14	36.76
12	ABAC.07.12.#.21			514.2.00736.#.12	514.2.00726.4.12	514.2.18929.#.12	514.2.00719.4.12						19.00	44.73	38.35
13	ABAC.07.13.#.21	514.2.18746.#.00	514.2.00696.4.00	514.2.00736.#.13	514.2.00726.4.13	514.2.18929.#.13	514.2.00719.4.13	121B.18.IC.CH	M0400098	38.90	M31 x 1 - 6H		20.60	46.32	39.94
14	ABAC.07.14.#.21			514.2.00736.#.14	514.2.00726.4.14	514.2.18929.#.14	514.2.00719.4.14						22.20	47.92	41.54
15	ABAC.07.15.#.21			514.2.00736.#.15	514.2.00726.4.15	514.2.18929.#.15	514.2.00719.4.15						23.80	49.52	43.14
16	ABAC.07.16.#.21			514.2.00736.#.16	514.2.00726.4.16	514.2.18929.#.16	514.2.00719.4.16						25.40	50.76	44.38
17	ABAC.07.17.#.21			514.2.00736.#.17	514.2.00726.4.17	514.2.18929.#.17	514.2.00719.4.17						27.00	51.56	45.18
18	ABAC.07.18.#.21			514.2.00736.#.18	514.2.00726.4.18	514.2.18929.#.18	514.2.00719.4.18						28.60	52.12	45.74
19	ABAC.07.19.#.21			514.2.00736.#.19	514.2.00726.4.19	514.2.18929.#.19	514.2.00719.4.19						30.20	52.29	45.91
20	ABAC.07.20.#.21			514.2.00736.#.20	514.2.00726.4.20	514.2.18929.#.20	514.2.00719.4.20						31.80	52.94	46.56
21	ABAC.07.21.#.21			514.2.00736.#.21	514.2.00726.4.21	514.2.18929.#.21	514.2.00719.4.21						33.30	53.74	47.36
22	ABAC.07.22.#.21			514.2.00736.#.22	514.2.00726.4.22	514.2.18929.#.22	514.2.00719.4.22						35.00	54.54	48.16
23	ABAC.07.23.#.21			514.2.00736.#.23	514.2.00726.4.23	514.2.18929.#.23	514.2.00719.4.23						36.50	55.34	48.96
24	ABAC.07.24.#.21			514.2.00736.#.24	514.2.00726.4.24	514.2.18929.#.24	514.2.00719.4.24						38.10	56.68	50.30

MODIFICATIONS MUST BE CARRIED OUT USING CAD SYSTEM. DOES THE CUSTOMER NEED TO BE INFORMED OF ANY CHANGE?

**GEOMETRIC TOLERANCE SYMBOLS**

CHARACTERISTIC	SYM	CHARACTERISTIC	SYM
STRAIGHTNESS	—	ANGULARITY	∠
FLATNESS	▭	RUN OUT	↗
ROUNDNESS	○	POSITION	⊕
CYLINDRICITY	⊘	CONCENTRICITY	⊙
PROFILE OF A LINE	⌒	SYMMETRY	≡
PROFILE OF A SURFACE	⌒	M.M.C.	Ⓜ
PARALLELISM	//	SQUARENESS	⊥

FOR EXPLANATION OF DIMENSIONS, TOLERANCES, NOTES, ETC. SEE BS308

**MATERIAL:**

TOLERANCES UNLESS OTHERWISE STATED

ALL DECIMAL PLACES ± 0.1  
HOLE DIAMETERS ± 0.05  
ANGULAR ± 2°

DRAWN AJ  
DATE 17/03/2011  
CHKD PL

∇ = CRITICAL CHARACTERISTIC ◊ = SIGNIFICANT CHARACTERISTIC (SEE AB-W07-03-01 FOR DESCRIPTION)

**ab** AB CONNECTORS LTD.  
A TT GROUP COMPANY

THIS DRAWING MAY ONLY BE ALTERED IF THE PART REMAINS INTERCHANGEABLE. IF NOT, A NEW DRAWING NUMBER MUST BE TAKEN.

**TITLE:**  
SIZE 21 - PATTERN 38999  
ASSY OF 90° ANGLE OUTLET  
SCREEN ADAPTOR AND SCREEN TRAP  
NUT FOR VARIOUS ENTRY SIZES

**PRODUCT DRAWING NUMBER**  
ABAC.07.###.21

Do not scale this drawing

**FINISH:**  
SEE PED 021

SHEET 1 OF 1

FINISH CODE VARN  
SEE PED 021