

- 1 HOUSING AND TERMINATION COVERS: THERMOPLASTIC, UL94V-0 RATED, COLOR BLACK.
SHELL: STEEL.
PIN CONTACTS: PHOSPHOR BRONZE.
- 2 2.54µm [.000100] MIN TIN-NICKEL OVER 3.81µm [.000150] MIN NICKEL OVER 2.54µm [.000100] MIN COPPER.
- 3 5.08µm [.000200] MIN TIN OVER 1.27µm [.000050] MIN COPPER. LUBRICATED AFTER PLATING.
- 4 EITHER 0.76µm [.000030] MIN GOLD PLATE OR GOLD FLASH OVER PALLADIUM NICKEL PLATE, 0.76µm [.000030] MIN TOTAL IN LOCALIZED PLATE AREA, 3.00µm [.000118] MIN TIN IN TERMINATION AREA, ALL OVER 1.27µm [.000050] MIN NICKEL.
- 5. RECOMMENDED WIRE: 28 AWG OR 30 AWG, SOLID OR 7 STRAND, PVC INSULATION WITH A 0.74 - 0.91 [.029 - .036] INSULATION DIAMETER.

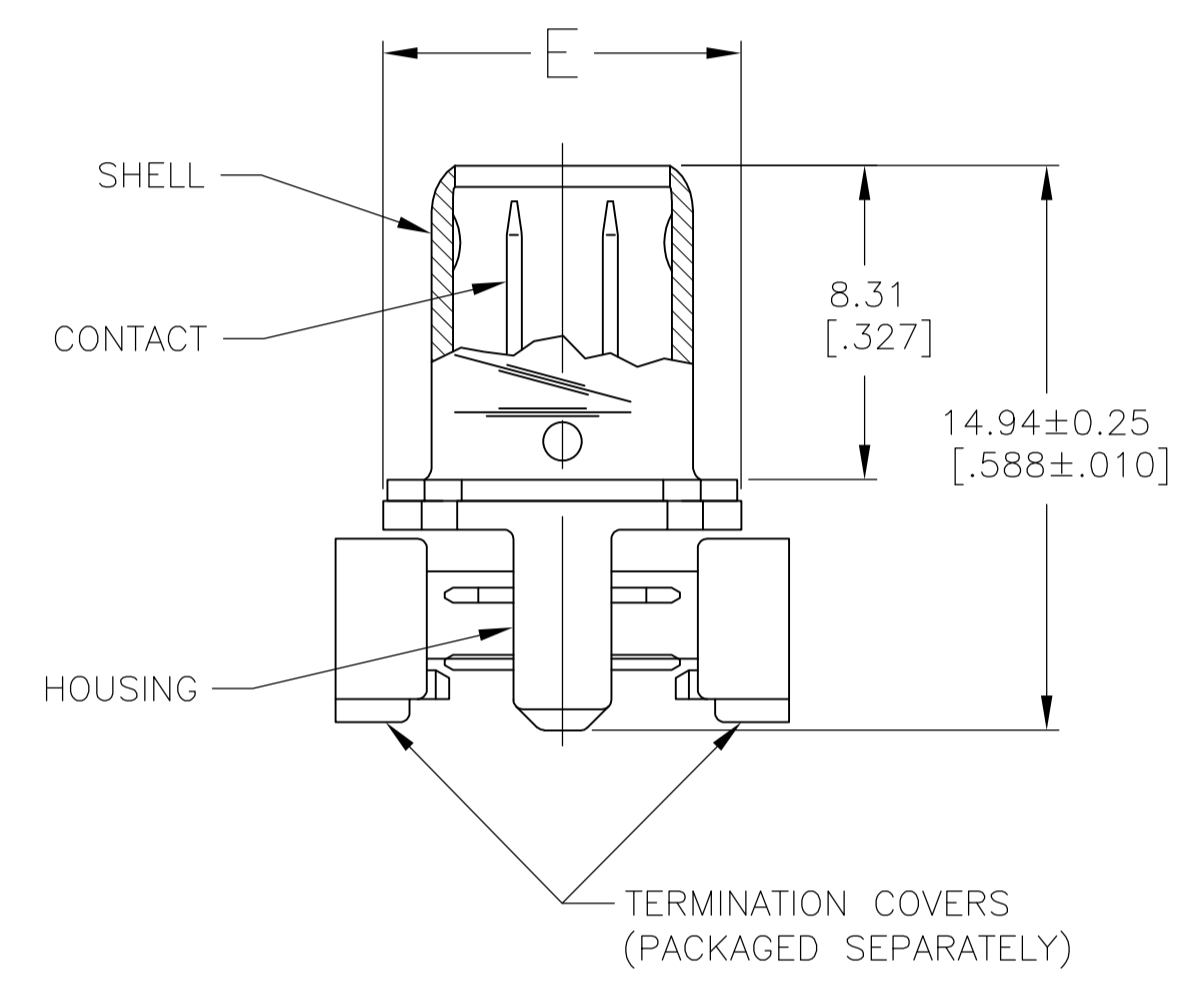

SUPERCEDED BY 5749621-9	9.47 [.373]	71.86 [2.829]	66.60 [2.622]	62.23 [2.450]	49	4	2	100	1-5749621-8
SUPERCEDED BY 5749621-5	7.44 [.293]	40.11 [1.579]	34.85 [1.372]	30.48 [1.200]	24	4	2	50	1-5749621-7
SUPERCEDED BY 5749621-7	7.44 [.293]	51.54 [2.029]	46.28 [1.822]	41.91 [1.650]	33	4	3	68	1-5749621-6
	9.47 [.373]	84.54 [3.329]	79.31 [3.122]	74.93 [2.950]	59	4	2	120	1-5749621-0
	9.47 [.373]	71.86 [2.829]	66.60 [2.622]	62.23 [2.450]	49	4	2	100	5749621-9
	9.47 [.373]	59.16 [2.329]	53.90 [2.122]	49.53 [1.950]	39	4	2	80	5749621-8
	7.44 [.293]	51.54 [2.029]	46.28 [1.822]	41.91 [1.650]	33	4	2	68	5749621-7
	7.44 [.293]	40.11 [1.579]	34.85 [1.372]	30.48 [1.200]	24	4	2	50	5749621-5
	7.44 [.293]	33.76 [1.329]	28.50 [1.122]	24.13 [.950]	19	4	2	40	5749621-4
	7.44 [.293]	26.14 [1.029]	20.88 [.822]	16.51 [.650]	13	4	2	28	5749621-3
	7.44 [.293]	24.87 [.979]	19.61 [.772]	15.24 [.600]	12	4	2	26	5749621-2
	7.44 [.293]	21.06 [.829]	15.80 [.622]	11.43 [.450]	9	4	2	20	5749621-1
	E	D	C	B	A	CONTACT FINISH	SHELL FINISH	NO OF POS	PART NUMBER

**COPYRIGHT 2005
TE CONNECTIVITY CORP
ALL RIGHTS RESERVED**

THIS DRAWING IS A CONTROLLED DOCUMENT.		DIN J. GERACE 17FEB05	TE Connectivity KIT, PLUG ASSEMBLY, 1.27[.050] SERIES, AMPLIMITE	
DIMENSIONS: INCHES		CHK S. SHUEY 17FEB05		
TOLERANCES UNLESS OTHERWISE SPECIFIED:		APVD M. WALMSLEY 17FEB05		NAME
0. PLC ± -	1. PLC ± -	PRODUCT SPEC		108-1228
2. PLC ± 0.13[.005]	3. PLC ± -	APPLICATION SPEC		114-40029
4. PLC ± -	ANGLES ± -	SIZE		A1
MATERIAL		WEIGHT		000779
FINISH SEE TABLE		DRAWING NO		5749621
1		CUSTOMER DRAWING		SCALE 5:1 SHEET 1 OF 1 REV D1