

EJECTION LATCHES OMITTED IN THIS VIEW FOR CLARITY

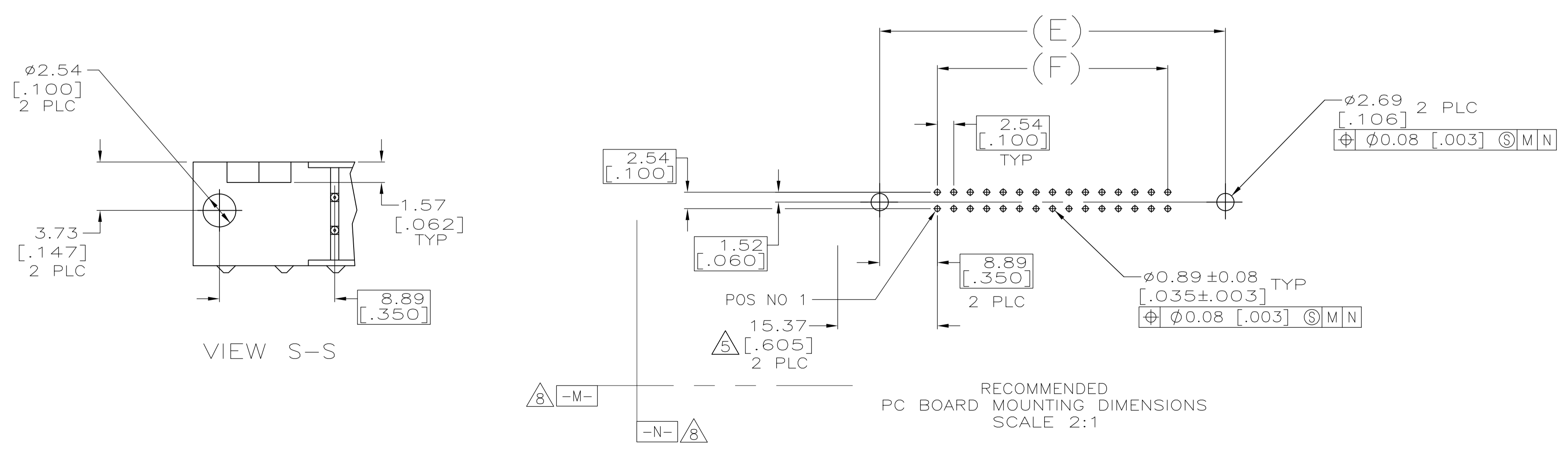
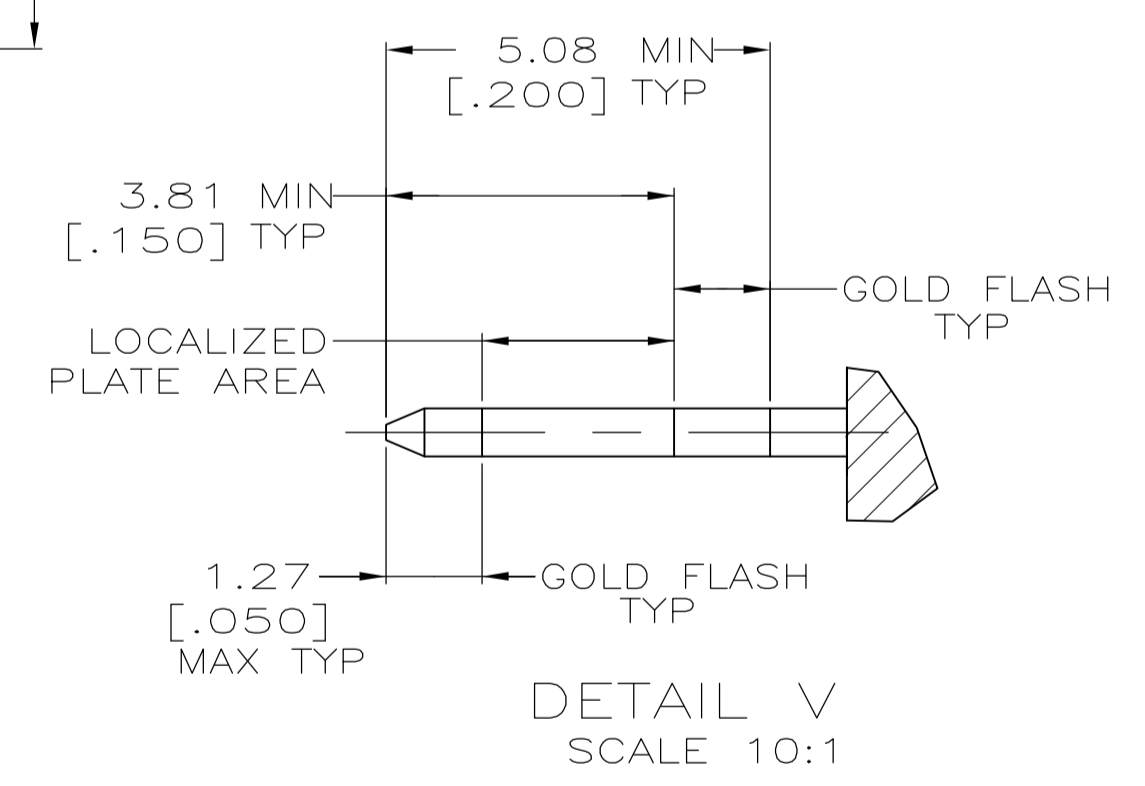
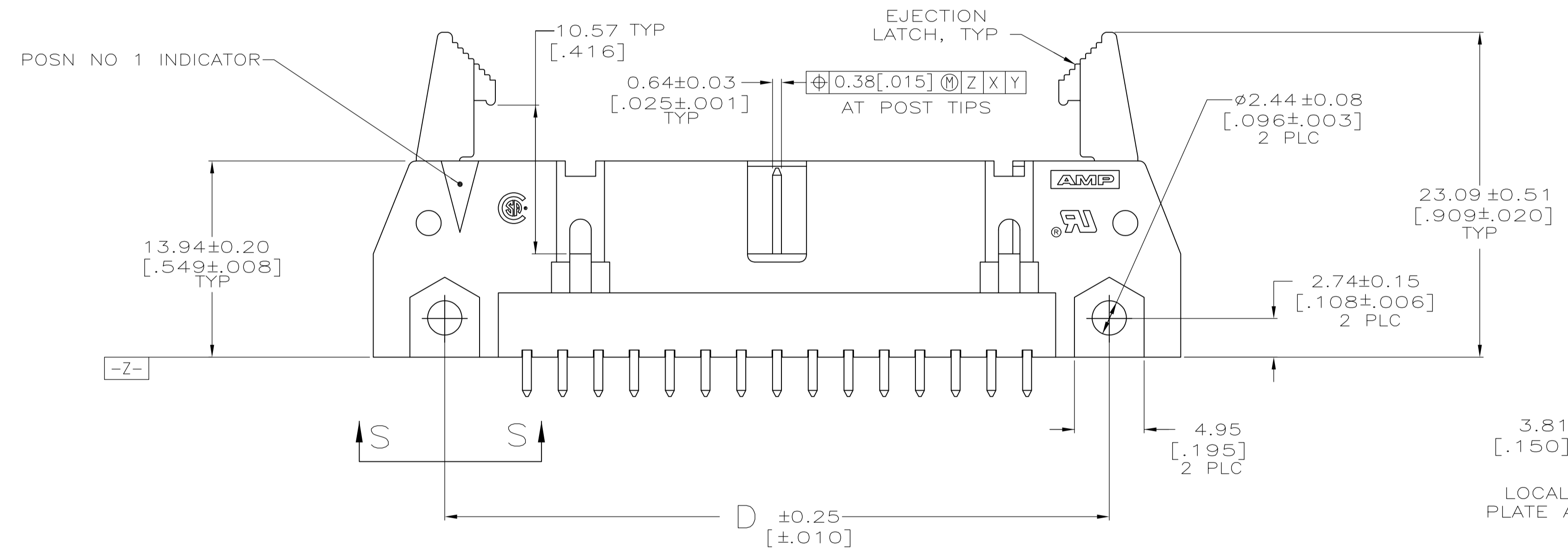
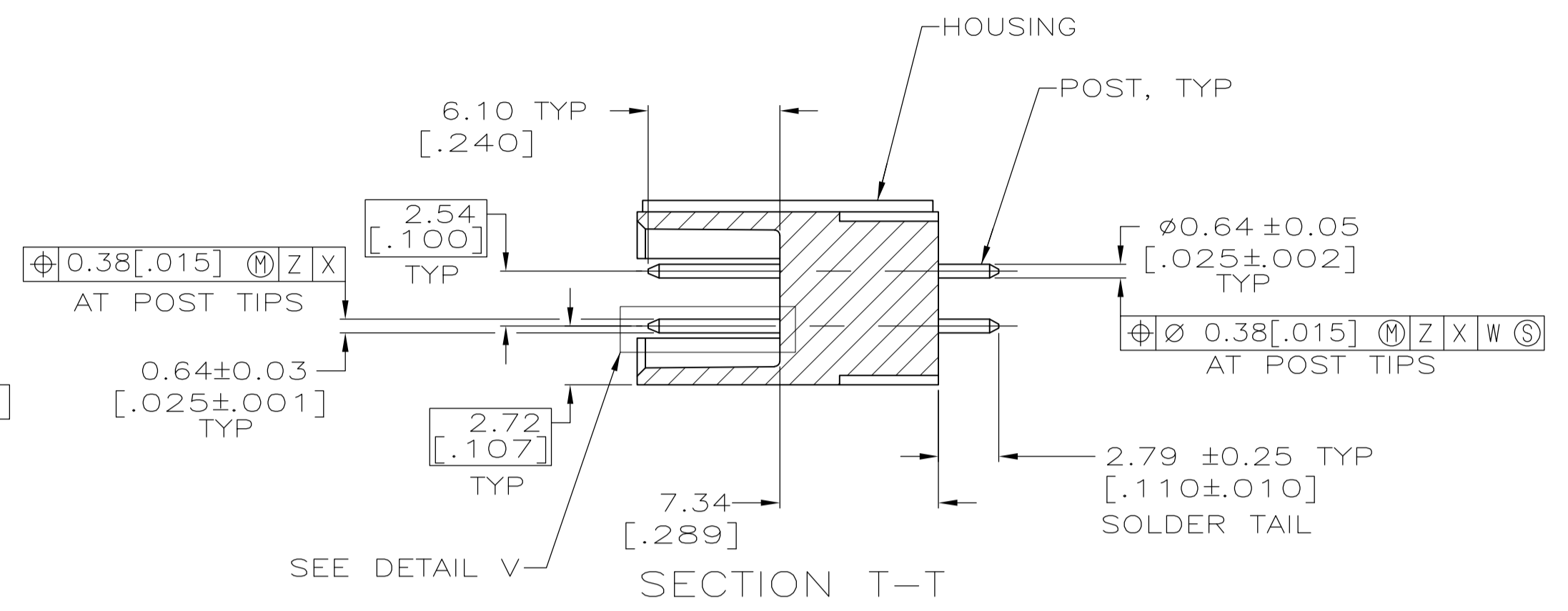
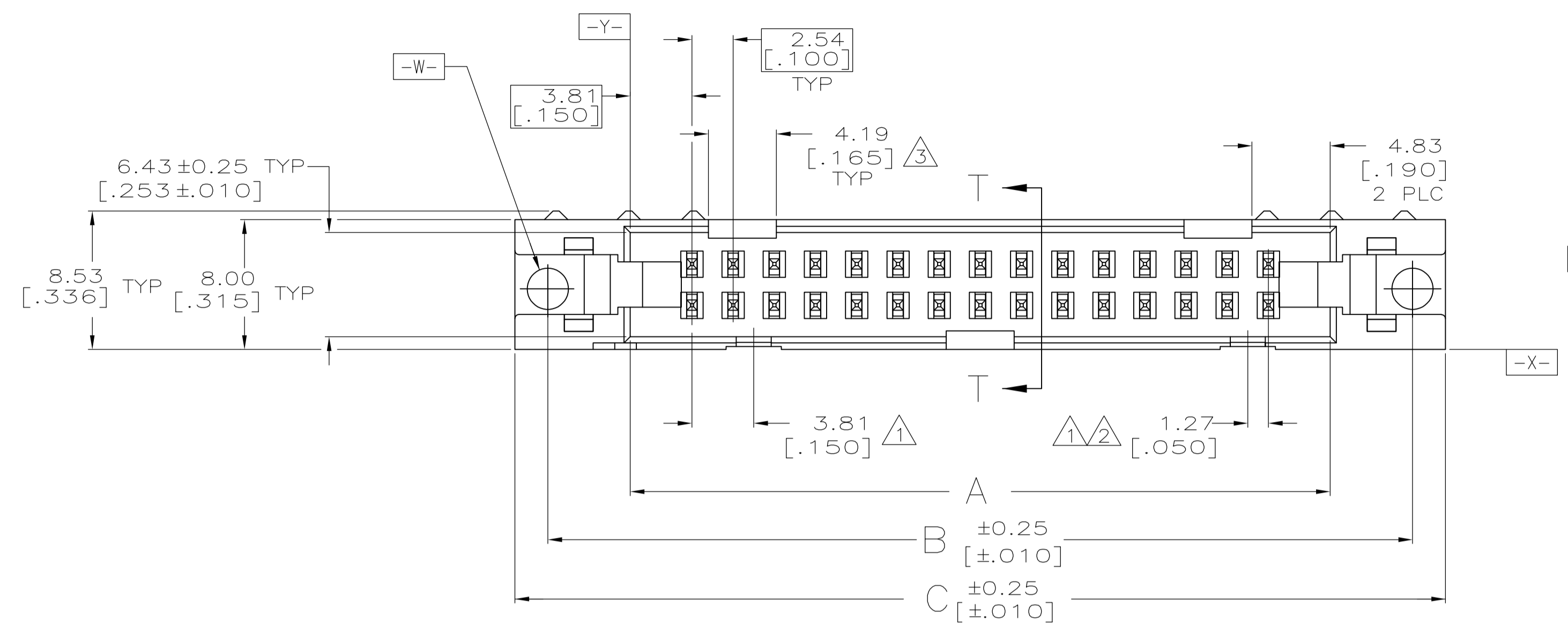

SEE SHEET 2 FOR TABLE & NOTES

VIEW S-S

RECOMMENDED PC BOARD MOUNTING DIMENSIONS SCALE 2:1

THIS DRAWING IS A CONTROLLED DOCUMENT.		DIN L VARELA - DOCKS 01-07-05		TE Connectivity	
DIMENSIONS: mm [INCHES]		CHK S BOLASH 01-07-05			
TOLERANCES UNLESS OTHERWISE SPECIFIED:		APPD M WALMSLEY 01-07-05		NAME	
0 PLC ± -		PRODUCT SPEC		HEADER ASSY, UNIVERSAL, AMP-LATCH	
1 PLC ± -		APPLICATION SPEC		108-40018	
2 PLC ± 0.13[005]		SIZE		A1	
3 PLC ± -		CASE CODE		00779	
4 PLC ± -		DRAWING NO		5499160	
ANGLES ± -		WEIGHT		-	
MATERIAL		CUSTOMER DRAWING		SCALE 4:1 SHEET 1 OF 2 REV D1	
FINISH					

- ① COORDINATE DIMENSION APPLIES FROM BASIC LOCATION.
- ② 10 AND 14 POSITION SIZES CONTAIN ONLY ONE SLOT FOR SNAP-IN POLARIZER (MILITARY POLARIZATION) LOCATED AS SHOWN.
- ③ 10 POSITION SIZES CONTAIN ONLY ONE SLOT FOR DUAL POLARIZATION, LOCATED AS SHOWN.
- 4. RECOMMENDED PRINTED CIRCUIT BOARD THICKNESS IS 1.57 [.062].
- ⑤ DISTANCE REQUIRED BY EJECTION LATCHES IN THE OPEN POSITION.
- ⑥ HOUSING & LATCHES, GLASS FILLED NYLON OR POLYESTER, UL94V-0 RATED, SEE TABLE FOR COLOR. POSTS: PH BRZ OR BRASS.
- ⑦ POSTS: GOLD FLASH OVER PALLADIUM-NICKEL PLATE, 0.76μm[.000030] MIN TOTAL ON THE LOCALIZED PLATE AREA, 2.54μm[.000100] MIN TIN PLATE ON THE SOLDER-TAIL, 1.27μm[.000050] MIN NICKEL UNDERPLATE ON THE ENTIRE POST.
-OR-
0.76μm[.000030] MIN GOLD PLATE ON THE LOCALIZED PLATE AREA, 2.54μm[.000100] MIN TIN PLATE ON THE SOLDER-TAIL, 1.27μm[.000050] MIN NICKEL UNDERPLATE ON THE ENTIRE POST.
- ⑧ DATUMS -M- & -N- TO BE ESTABLISHED BY CUSTOMER.

OBSOLETE	BLUE	78.74 [3.100]	96.52 [3.800]	90.42 [3.560]	100.58 [3.960]	96.52 [3.800]	86.36 [3.400]	64	3-5499160-2
	BLUE	73.66 [2.900]	91.44 [3.600]	85.34 [3.360]	95.50 [3.760]	91.44 [3.600]	81.28 [3.200]	60	3-5499160-1
	BLUE	60.96 [2.400]	78.74 [3.100]	72.64 [2.860]	82.80 [3.260]	78.74 [3.100]	68.58 [2.700]	50	3-5499160-0
	BLUE	48.26 [1.900]	66.04 [2.600]	59.94 [2.360]	70.10 [2.760]	66.04 [2.600]	55.88 [2.200]	40	2-5499160-9
OBSOLETE	BLUE	40.64 [1.600]	58.42 [2.300]	52.32 [2.060]	62.48 [2.460]	58.42 [2.300]	48.26 [1.900]	34	2-5499160-8
OBSOLETE	BLUE	35.56 [1.400]	53.34 [2.100]	47.24 [1.860]	57.40 [2.260]	53.34 [2.100]	43.18 [1.700]	30	2-5499160-7
	BLUE	30.48 [1.200]	48.26 [1.900]	42.16 [1.660]	52.32 [2.060]	48.26 [1.900]	38.10 [1.500]	26	2-5499160-6
	BLUE	22.86 [.900]	40.64 [1.600]	34.54 [1.360]	44.70 [1.760]	40.64 [1.600]	30.48 [1.200]	20	2-5499160-4
OBSOLETE	BLUE	17.78 [.700]	35.56 [1.400]	29.46 [1.160]	39.62 [1.560]	35.56 [1.400]	25.40 [1.000]	16	2-5499160-3
	BLUE	15.24 [.600]	33.02 [1.300]	26.92 [1.060]	37.08 [1.460]	33.02 [1.300]	22.86 [.900]	14	2-5499160-2
	BLUE	10.16 [.400]	27.94 [1.100]	21.84 [.860]	32.00 [1.260]	27.94 [1.100]	17.78 [.700]	10	2-5499160-1
	BLACK	78.74 [3.100]	96.52 [3.800]	90.42 [3.560]	100.58 [3.960]	96.52 [3.800]	86.36 [3.400]	64	1-5499160-2
OBSOLETE	BLACK	73.66 [2.900]	91.44 [3.600]	85.34 [3.360]	95.50 [3.760]	91.44 [3.600]	81.28 [3.200]	60	1-5499160-1
	BLACK	60.96 [2.400]	78.74 [3.100]	72.64 [2.860]	82.80 [3.260]	78.74 [3.100]	68.58 [2.700]	50	1-5499160-0
	BLACK	48.26 [1.900]	66.04 [2.600]	59.94 [2.360]	70.10 [2.760]	66.04 [2.600]	55.88 [2.200]	40	5499160-9
	BLACK	40.64 [1.600]	58.42 [2.300]	52.32 [2.060]	62.48 [2.460]	58.42 [2.300]	48.26 [1.900]	34	5499160-8
OBSOLETE	BLACK	35.56 [1.400]	53.34 [2.100]	47.24 [1.860]	57.40 [2.260]	53.34 [2.100]	43.18 [1.700]	30	5499160-7
	BLACK	30.48 [1.200]	48.26 [1.900]	42.16 [1.660]	52.32 [2.060]	48.26 [1.900]	38.10 [1.500]	26	5499160-6
OBSOLETE	BLACK	27.94 [1.100]	45.72 [1.800]	39.62 [1.560]	49.78 [1.960]	45.72 [1.800]	35.56 [1.400]	24	5499160-5
	BLACK	22.86 [.900]	40.64 [1.600]	34.54 [1.360]	44.70 [1.760]	40.64 [1.600]	30.48 [1.200]	20	5499160-4
	BLACK	17.78 [.700]	35.56 [1.400]	29.46 [1.160]	39.62 [1.560]	35.56 [1.400]	25.40 [1.000]	16	5499160-3
	BLACK	15.24 [.600]	33.02 [1.300]	26.92 [1.060]	37.08 [1.460]	33.02 [1.300]	22.86 [.900]	14	5499160-2
	BLACK	10.16 [.400]	27.94 [1.100]	21.84 [.860]	32.00 [1.260]	27.94 [1.100]	17.78 [.700]	10	5499160-1
	HOUSING AND LATCHES COLOR	F	E	D	C	B	A	NO OF POSN	PART NUMBER

THIS DRAWING IS A CONTROLLED DOCUMENT.		DIN L VARELA - DOCKS 01-07-05		 TE Connectivity	
DIMENSIONS: mm [INCHES]		TOLERANCES UNLESS OTHERWISE SPECIFIED:			
0 PLC ± - 1 PLC ± - 2 PLC ± 0.13[.005] 3 PLC ± - 4 PLC ± - ANGLES ± -		APVO M WALMSLEY 01-07-05 NAME PRODUCT SPEC 108-40018 APPLICATION SPEC		HEADER ASSY, UNIVERSAL, AMP-LATCH	
MATERIAL SEE SHEET 1		FINISH SEE SHEET 1		SIZE CAGE CODE DRAWING NO RESTRICTED TO A1 00779 5499160	
CUSTOMER DRAWING				SCALE 1:1 SHEET 2 OF 2 REV D1	