

RECOMMENDED MOUNTING HOLE PATTERN FOR .063 THICK P.C. BOARD

- 1 POST TO WITHSTAND 13 NEWTONS (3LBS.) MIN. AXIAL FORCE IN BOTH DIRECTIONS SHOWN WITHOUT DISLODGING.
- 2 TOLERANCES APPLY TO SOLDER SIDE OF BOARD.
- 3 MEASURED AT SURFACE -A-
- 4 PLASTIC FLASH PERMITTED IN THIS AREA.
- 5 PARTS COMPLY WITH AMP SOLDERABILITY SPEC. NO. 109-11-2.
- 6 ONE HOLE MAY BE UNDERSIZED (.065 - .060 DIA.) FOR ASSEMBLY RETENTION DURING WAVE SOLDERING.
- 7 MATERIAL: HEADER-THERMOPLASTIC POLYESTER
GLASS-FILLED 94V-0 (NATURAL)
POST-COPPER ALLOY (TIN PLATED)
- 8 COORDINATE DIMENSION APPLIES FROM CENTER OF ACTUAL FEATURE.
- 9 PLASTIC BURRS CAUSED BY CUT-OFF TOOLING ARE PERMITTED WITHIN THE MAXIMUM TOLERANCE ENVELOPE.
- 10 POST TO BE MEASURED WHEN STRIP IS HELD FLAT.
- 11 POST MUST WITHSTAND TWO 90° BENDS AGAINST EXTRUSION WITHOUT BREAKING.
- 12 DIMENSION SHOULD BE .500-.650 WHEN MATING WITH A MTA 156 CONNECTOR ASSEMBLY OR .500 MIN WHEN MATING WITH A SL-156 CONNECTOR ASSEMBLY.
- 13 PIN BURR OF .005 MAX. VERTICAL AND .003 MAX. HORIZONTAL PERMITTED AT POST TIPS ON BOTH ENDS.

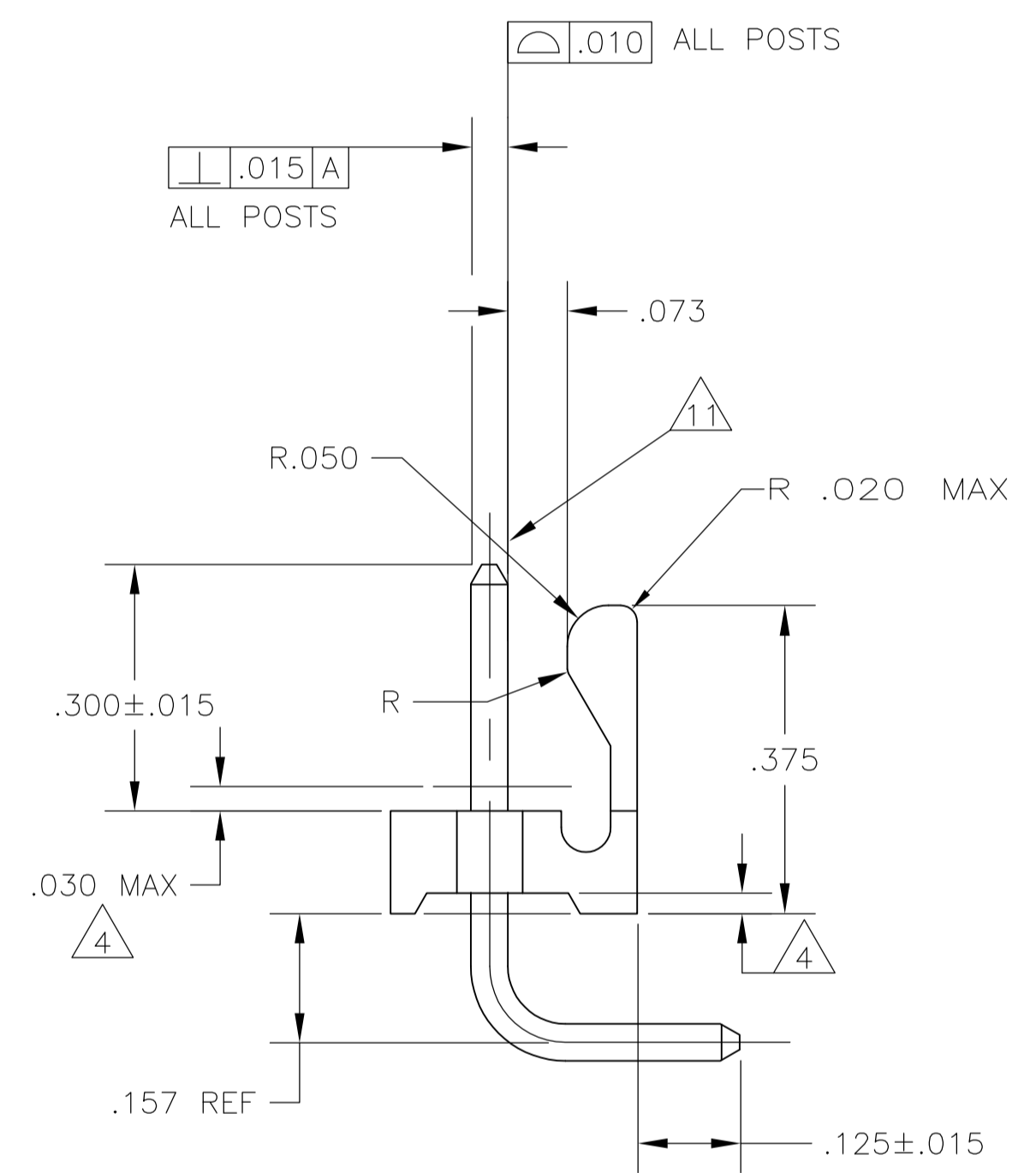
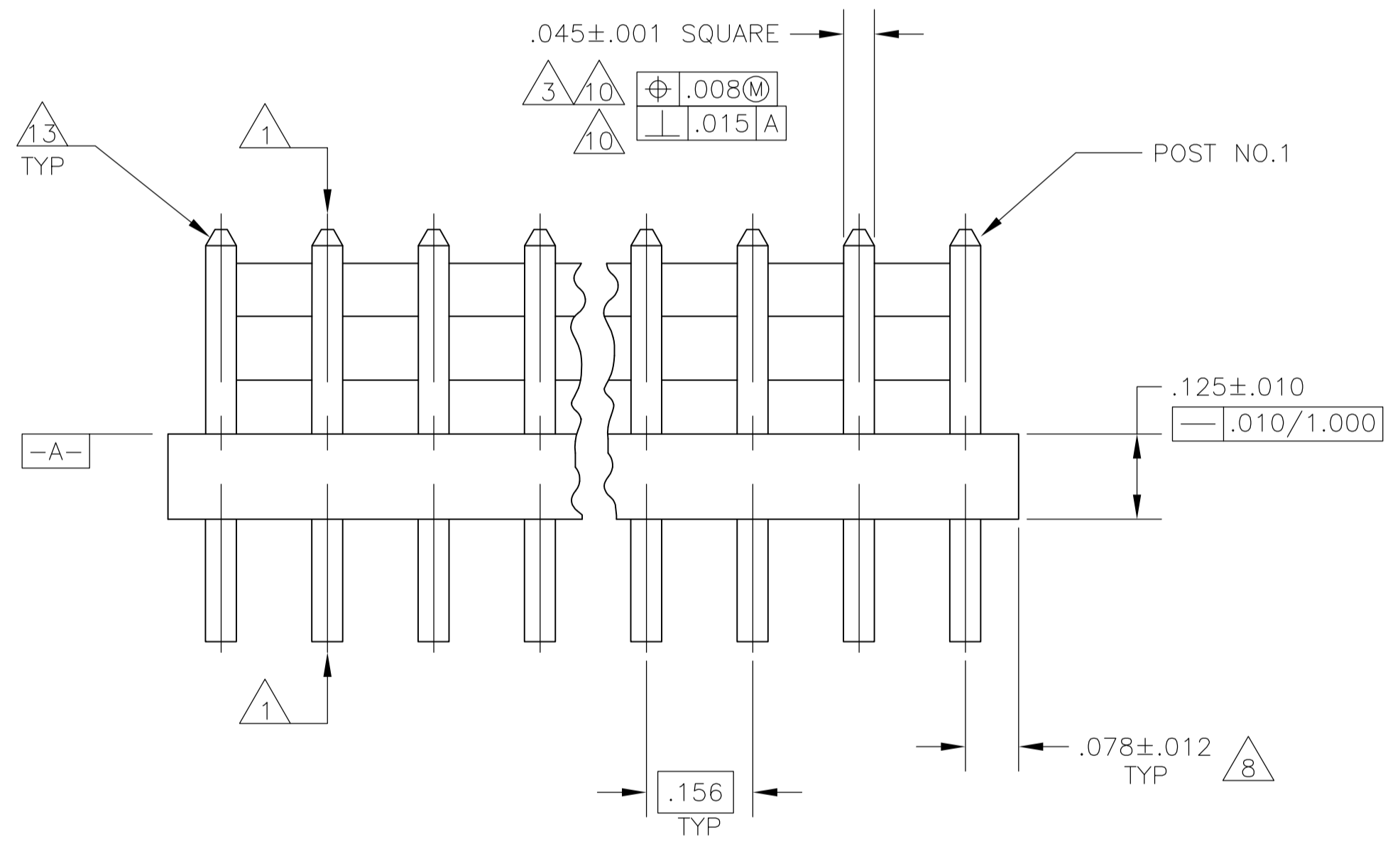

| | | | |
|------|------|-------|-------|
| .068 | 1.73 | - | - |
| .065 | 1.65 | 1.000 | 25.40 |
| .063 | 1.60 | .650 | 16.51 |
| .060 | 1.52 | .500 | 12.70 |
| .045 | 1.14 | .450 | 11.43 |
| .030 | 0.76 | .425 | 10.80 |
| .015 | 0.38 | .300 | 7.62 |
| .012 | 0.30 | .180 | 4.57 |
| .010 | 0.25 | .157 | 3.99 |
| .008 | 0.20 | .156 | 3.96 |
| .005 | 0.13 | .125 | 3.18 |
| .003 | 0.08 | .078 | 1.98 |
| .001 | 0.03 | .073 | 1.85 |
| .000 | 0.00 | .070 | 1.78 |

CONVERSION TABLE

| | | | |
|-------|-------|---------------------|-------------|
| 95.10 | 3.744 | 24 | 2-640387-4 |
| 91.14 | 3.588 | 23 | 2-640387-3 |
| 87.17 | 3.432 | 22 | 2-640387-2 |
| 83.21 | 3.276 | 21 | 2-640387-1 |
| 79.25 | 3.120 | 20 | 2-640387-0 |
| 75.29 | 2.964 | 19 | 1-640387-9 |
| 71.32 | 2.808 | 18 | 1-640387-8 |
| 67.36 | 2.652 | 17 | 1-640387-7 |
| 63.40 | 2.496 | 16 | 1-640387-6 |
| 59.44 | 2.340 | 15 | 1-640387-5 |
| 55.47 | 2.184 | 14 | 1-640387-4 |
| 51.51 | 2.028 | 13 | 1-640387-3 |
| 47.55 | 1.872 | 12 | 1-640387-2 |
| 43.59 | 1.716 | 11 | 1-640387-1 |
| 39.62 | 1.560 | 10 | 1-640387-0 |
| 35.66 | 1.404 | 9 | 640387-9 |
| 31.70 | 1.248 | 8 | 640387-8 |
| 27.74 | 1.092 | 7 | 640387-7 |
| 23.77 | .936 | 6 | 640387-6 |
| 19.81 | .780 | 5 | 640387-5 |
| 15.85 | .624 | 4 | 640387-4 |
| 11.89 | .468 | 3 | 640387-3 |
| 7.92 | .312 | 2 | 640387-2 |
| MM | [IN] | NUMBER OF POSITIONS | PART NUMBER |

THIS DRAWING IS A CONTROLLED DOCUMENT.

DIN S. HOOVER 02NOV02
 CHK. D. ROSSI 02NOV02
 APVD. D. ROSSI 02NOV02

TE Connectivity

MTA-156 HEADER ASSEMBLY, FRICTION LOCK, RIGHT ANGLE, REAR BEND, .045 SQUARE POST, TIN PLATED

SIZE: A1
 WEIGHT: -
 CUSTOMER DRAWING

SCALE: 5:1
 SHEET: 1 of 1
 REV: AD