



PART NO.

ST Series

REVISIONS

ECN #	REV	DESCRIPTION	DRAWN	DATE	CHECKD	DATE	APPRVD	DATE
-	A	RELEASED	PRE	07/6/12	SHA	07/6/12		21/6/12

3.175 mm, 1 / 8 inches Shank

Features :

- For use in multi-layer PCB drilling applications
- Designed for drilling Glass Fibre based printed circuit boards
- Enlarged shank for better centring and torque transfer
- Drill bit manufactured from solid tungsten carbide and shank from stainless steel
- Overall length 38.1 mm (1 1/2 inches)

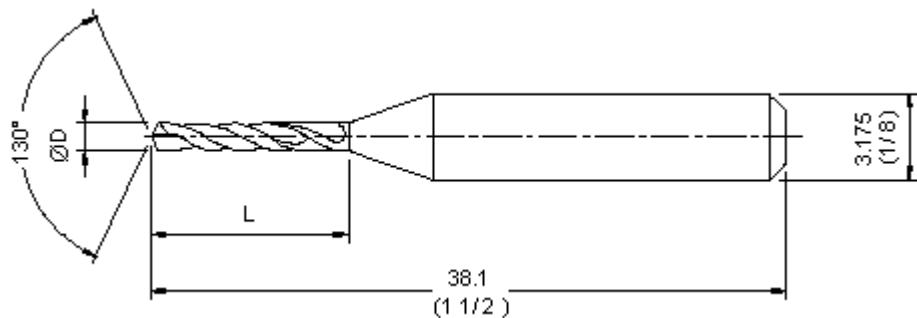

Dimensions : Millimetres (Inches)

Specification Table

Drill Size (D)	Flute Length (L)	Part Number
0.8	10	ST-0.80
1		ST-1.00
1.3	12	ST-1.30
1.6		ST-1.60
2		ST-2.00

Dimensions : Millimetres

www.element14.com
 www.farnell.com
 www.newark.com
 www.cpc.co.uk
 www.mcmelectronics.com

Important Notice: This data sheet and its contents (the "Information") belong to the Premier Farnell Group (the "Group") or are licensed to it. No licence is granted for the use of it other than for information purposes in connection with the products to which it relates. No licence of any intellectual property rights is granted. The Information is subject to change without notice and replaces all data sheets previously supplied. The Information supplied is believed to be accurate but the Group assumes no responsibility for its accuracy or completeness, any error in or omission from it or for any use made of it. Users of this data sheet should check for themselves the Information and the suitability of the products for their purpose and not make any assumptions based on information included or omitted. Liability for loss or damage resulting from any reliance on the Information or use of it (including liability resulting from negligence or where the Group was aware of the possibility of such loss or damage arising) is excluded. This will not operate to limit or restrict the Group's liability for death or personal injury resulting from its negligence. Duratool is the registered trademark of the Group. © Premier Farnell plc 2012.

TOLERANCES:
 UNLESS OTHERWISE SPECIFIED, DIMENSIONS ARE FOR REFERENCE PURPOSES ONLY.

DRAWN BY:	DATE:
PRE	07/06/21
CHECKED BY:	DATE:
SHA	07/06/12
APPROVED BY:	DATE:
	21/06/12

DRAWING TITLE:			
Single Sided PCB Drill Bits - ST Series			
SIZE	DWG NO.	ELECTRONIC FILE	REV
A	M100000030	313210_DWG	A
SCALE: NTS		U.O.M.: mm	SHEET: 1 OF 1