

RATED
10A. / CONTACT CONTINUOUS @ 80°C MAX.
15A. @ 20°C INTERMITTANT

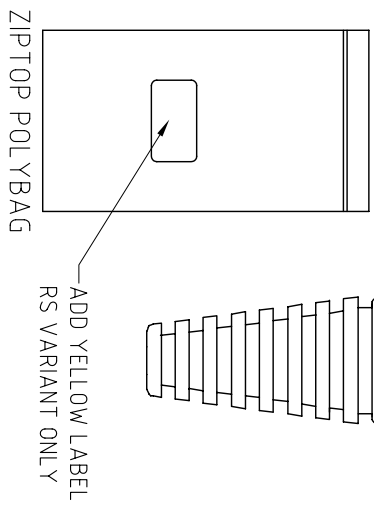
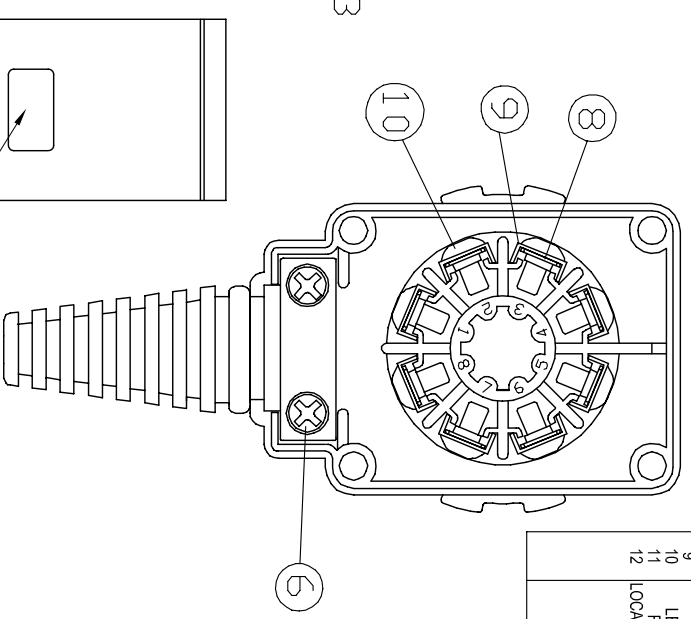

ITEM	DESCRIPTION	MATERIAL	No. PER	P/No.
1	BODY FRONT	POLYAMIDE (BLK)	1	FCR 2072SA7
2	BODY COVER	POLYAMIDE (BLK)	1	FCR 2072SA8
3	CABLE CLAMP LARGE	POLYAMIDE / GF (BLK)	1	FCR 2072SA9
4	CABLE CLAMP SMALL	POLYAMIDE / GF (BLK)	1	FCR 2072SA10
5	GROMMET #2	PVC	1	FCR 6938SA12
6	SCREW (CABLE CLAMP)	STEEL NI PLT M3x15	2	FCR 6938SA2
7	SCREW (COVER)	STEEL / BLK #6x15	4	FCR 6938SA3
8	CONTACT WASHER	BRASS / Sn PLATED	8	FCR 6938SA4
9	CONTACT	BRASS / NI PLATED	8	FCR 6938SA5
10	M3X6 MUSHROOM HEAD SCREW	STEEL / NI PLT	8	FCR 6938SA6
11	LOCKING RING	NYLON (ORANGE)	1	FCR 2072SA11

VARIANTS			
P/No.	DESCRIPTION	LEAFLET	BAG LABEL
FOR2072	8P/CP	FOR2072SA12	NO
FOR20721	8P/CP RS 215-6414	FOR2072SA13	YES
FOR2073	8P/CP SOLDER VERSION	FOR2072SA12	NO

PACKING: INDIVIDUALLY PACKED IN POLY BAG WITH 1 LEAFLET PER BAG + LABEL WHERE REQUIRED.

NOTE: VARIANT FCR2073 HAS ITEMS 9 AND 10 OMITTED.

ROHS
COMPLIANT

TOLERANCE
NO DEC. PLACE ±
1 DEC. PLACE ±0.20
2 DEC. PLACE ±
HOLE Ø ±
ANGLES ±1/2°
UNLESS
OTHERWISE STATED

DO NOT SCALE

ISS.	AMEND	DATE
1	1 st DRAWN	20/03/96
2	SA12 WAS F06741	26/04/96
3	WAS FC6938	04/07/96
4	SA5 WAS Sn PLT	30/07/96
5	PIN6 UPDATED	08/10/97
6	CL2073 NOTE	06/10/99
7	WAS CL2072	07/12/04
8	ITEM 10 DESC.	09/05/05
9	FOR6938SA12	01/06/05
10	LEAFLET DETAIL	12/01/07
11	RS LABEL ADD	23/07/07
12	LOCATION GROOVE ADD	20/03/12

Cliff Electronic Components Ltd.

76 Holmechurpe Avenue, Holmechurpe Industrial Estate,
Redhill, Surrey, RH1 2PF, England, UK

Tel: 01737-771375 Fax: 01737-766012 Website: www.cliffuk.co.uk
THE CONTENTS OF THIS DOCUMENT MUST NOT BE COPIED OR DISCLOSED TO A 3rd PARTY WITHOUT WRITTEN PERMISSION OF CLIFF UK. © 1996

DIMENSIONS IN MILLIMETERS UNLESS OTHERWISE STATED. WORK TO DIMENSIONS. REMOVE ALL BURRS. IF IN DOUBT ASK

MATERIAL: COMPOSITE
FINISH: CLEAN
DRAWN: CAMU

APPROVED: RWT

TITLE: CLIFFCON 8P/CP PLUG (8 POLE)
DRWG. No. **FCR 2072**

FORM: ADDRWH