

ISS.	AMEND	DATE
1	WAS DPJ199-J	14/04/98
2	FC79031 ADDED	21/09/98
3	MAT. REF CHANGED	09/02/99
4	WAS FC7903	28/09/04
5	TABLE UPDATED	13/02/13

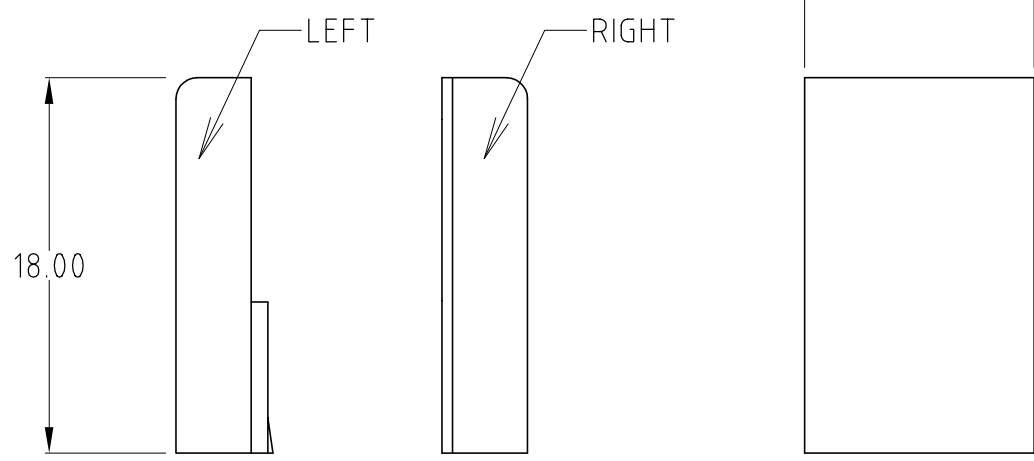
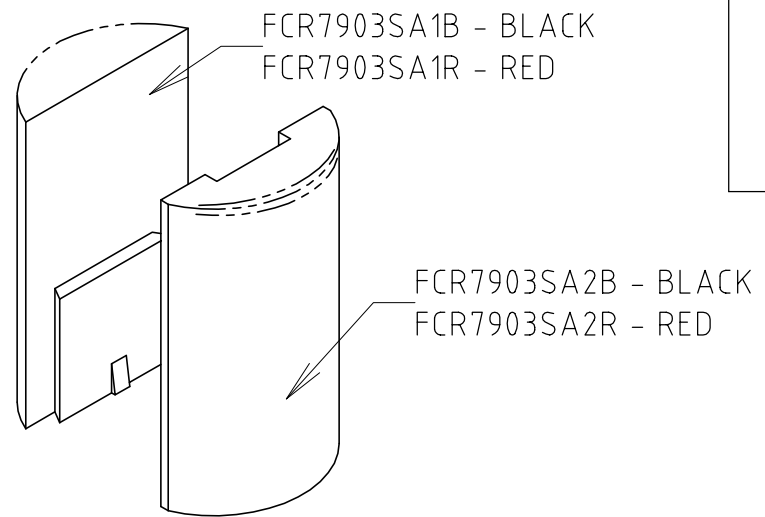
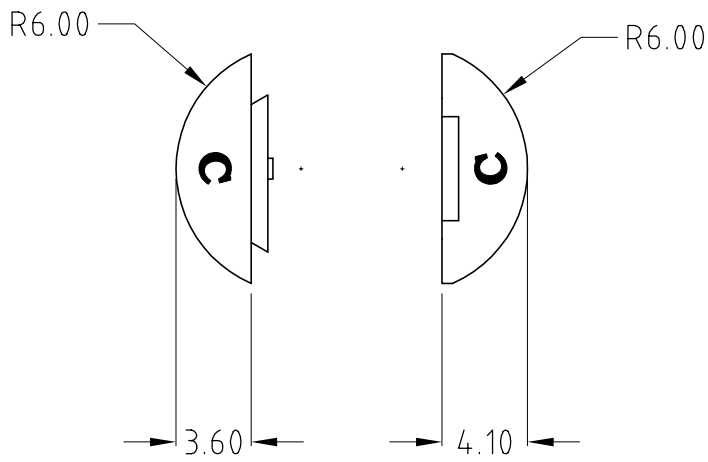

VARIANTS			
PART No.	COLOUR	LEFT	RIGHT
FCR7903	BLACK	FCR7903SA1B	FCR7903SA2B
FCR79031	RED	FCR7903SA1R	FCR7903SA2R

BULK PACKED 100x LEFT + 100x RIGHT PER COLOUR.

**RoHS**  
COMPLIANT

**TOLERANCE**  
 NO DEC. PLACE ± 0.50  
 1 DEC. PLACE ± 0.20  
 2 DEC. PLACE ± 0.10  
 HOLE Ø ± 0.10  
 ANGLES ± 1/2°  
 UNLESS OTHERWISE STATED

1ST DRAWN : 22/9/97

**Cliff Electronic Components Ltd.**  
 76 Holmethorpe Avenue, Holmethorpe Industrial Estate,  
 Redhill, Surrey, RH1 2PF, England, UK  
 Tel: 01737-771375 Fax: 01737-766012 Website: www.cliffuk.co.uk

DIMENSIONS IN MILLIMETERS UNLESS OTHERWISE STATED. WORK TO DIMENSIONS. REMOVE ALL BURRS. IF IN DOUBT ASK.

3rd ANGLE PROJECTION:

DO NOT SCALE

MATERIAL: NYLON 6 - UBE 1013NW8 UL FILE E48133

TITLE: CONTRACTOR TERMINAL END CAPS (1 PAIR)

FINISH: 27 VDI - CLEAN

DRWG. No. **FCR7903**

THE CONTENTS OF THIS DOCUMENT MUST NOT BE COPIED OR DISCLOSED TO A 3rd PARTY WITHOUT WRITTEN PERMISSION OF CLIFF UK. © 1998

DRAWN: T.J.O.

APPROVED: D.P.J.

FORM: A4DRWGF