

73 CKT
SCALE 3:2

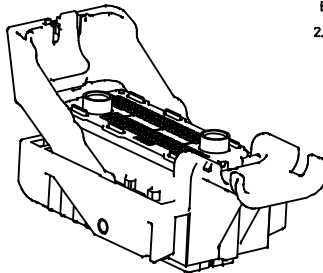

66 CKT
SCALE 3:2

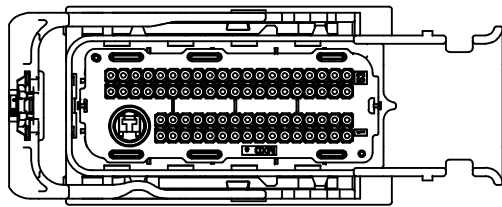
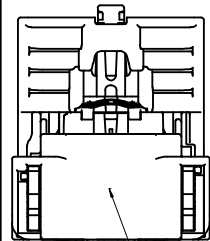

RECOMMENDED LOCATION
FOR NOTE 2D

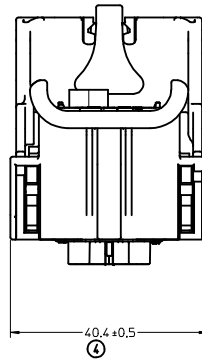
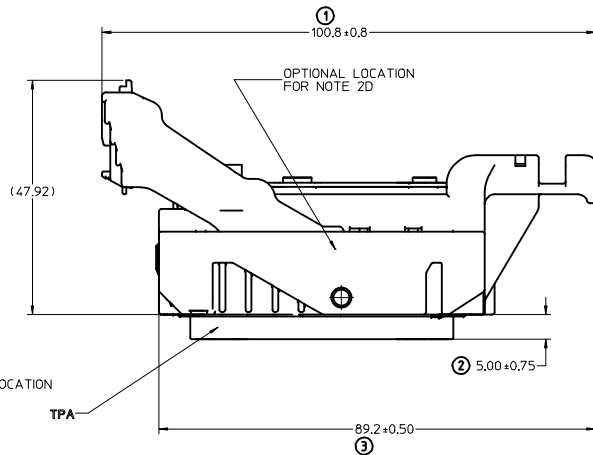

4

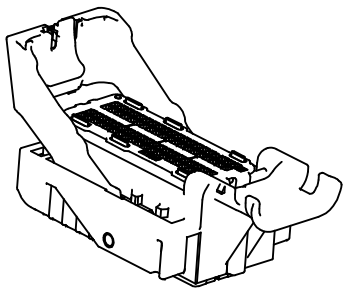

80 CKT
SCALE 3:2

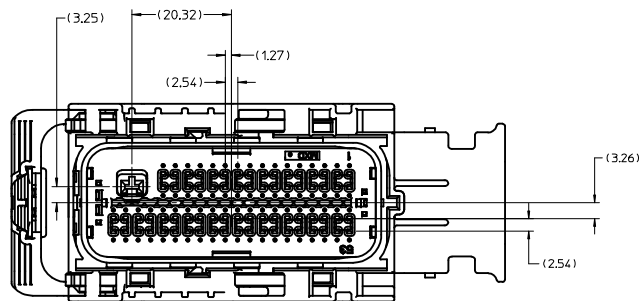

NOTES: UNLESS OTHERWISE SPECIFIED

1. MATERIAL:

- A. RESIN: SEE COMPONENT DRAWINGS
- B. COLOR: SEE TABLE

2. DESIGN - GENERAL:

- A. THIS IS A 100% CAD GENERATED PART. THE CAD MATHEMATICAL DATA IS THE MASTER FOR THIS PART. FOR DIMENSIONAL OR ANY INFORMATION NOT SHOWN ON THIS DRAWING, ANALYZE THE CAD MODEL.
- B. TOLERANCES:
 - a. LINEAR XX ± 0.30
 - XXX ± 0.10
 - XXXX ± 0.10
 - b. ANGULAR X° ± 3.0°
- C. CORNERS SHOWN AS SHARP TO BE R 0.2 MAX.
- D. FOLLOWING PRODUCTION CODES TO BE PERMANENTLY MARKED & HUMAN READABLE TO A LETTER HEIGHT < 3mm.
 - LINE #1: MATERIAL #: XXXXX-XXXX
 - LINE #2: DATE CODE: JJJJ (JULIAN DAY, LAST DIGIT OF YEAR)
 - LINE #3: INSPECTION MACHINE CODE + SERIAL #:X_XXXXX
- E-1. PARTS MUST BE FREE OF DISCOLORATION, SALT RESIDUE AND OTHER IMPERFECTIONS THAT AFFECT FIT OR FUNCTION.
- E-2. SCRATCHES OR DENTS NOT TO EXCEED 0.15mm IN DEPTH.
- F. CHANGES IN DESIGN FROM PART PREVIOUSLY APPROVED REQUIRES PRIOR ENGINEERING APPROVAL. THIS INCLUDES BUT IS NOT LIMITED TO DRAFT, MATERIAL OR PROCESSING.
- G. SHALL CONFORM TO THE FOLLOWING PACKAGING SPECIFICATION: PK-31300-019

3. DESIGN - MANUFACTURING:

- A. DRAFT TO BE WITHIN TOLERANCE.
- B. ALLOWABLE FLASH 0.2 MAX HIGH X 0.13 MAX THICK.
- C. ALLOWABLE PARTING LINE MISMATCH 0.2 MAX.
- D. EJECTOR PINS MARK TO BE FLUSH TO 0.25 MAX DEPRESSED.
- E. ALLOWABLE GATE VESTIGE TO BE FLUSH TO 0.25 MAX PROTRUSION.

4. SYSTEM REQUIREMENTS:

- WHEN TESTED TO SAE/USCAR-2 REV: 3, APRIL 2001, AND GMW #3191, AUGUST 22, 2000 (DRAFT).
- A. TPA (WITHOUT TERMINALS)
 - a. INSERTION FORCE FROM PRE-SET TO LOCK: ≥20
 - b. REMOVAL FORCE FROM PRE-SET: ≥20
- B. CPA
 - a. INSERTION FORCE FROM PRE-SET TO LOCK WITH CONNECTOR UN-MATED: ≥60N
 - b. REMOVAL FORCE FROM PRE-SET: ≥30N
- C. GROMMET CAP
 - a. REMOVAL FORCE FROM HOUSING WITH ENGAGED LATCHES: ≥110N
- D. MATE ASSIST LEVER
 - a. INADVERTENT ACTUATION FORCE DURING SHIPPING, HANDLING OR PRE-ASSEMBLY: ≥190N

REV	DESCRIPTION
F86	ADDED PART NUMBERS 34566-5243 34566-5253
F85	ADDED PART NUMBERS 34566-5193 34566-5213 34566-5273 34566-5233
F84	ADDED PART NUMBERS 34566-5183
F83	ADDED PART NUMBERS 34566-5163 34566-5173
F82	ADDED PART NUMBERS 34566-5063 34566-5073 34566-5083 34566-5093 34566-5113 34566-5123 34566-5193 34566-5143 34566-5163
F81	ADDED PART NUMBERS 34566-5023 34566-5033 34566-5043 34566-5053
F80	ADDED PART NUMBERS 34566-4933 34566-4943 34566-4953 34566-4963 34566-4973 34566-4983 34566-4993 34566-5013
F79	ADDED PART NUMBERS 34566-4883 34566-4893 34566-4913 34566-4923
F78	ADDED PART NUMBERS 34566-4743 34566-4753 34566-4763 34566-4773 34566-4783 34566-4793 34566-4813 34566-4823 34566-4833 34566-4843 34566-4853 34566-4863 34566-4873
F77	ADDED PART NUMBERS 34566-4733
F76	ADDED PART NUMBERS 34566-4712 34566-4723
F75	ADDED PART NUMBERS 34822-0033 34822-0043
F74	ADD PART NUMBER 34566-4643 34566-4653 34566-4663 34566-4673 34566-4683 34566-4693

ENTER DESCRIPTION TEC NO: UAU2013-0662 DRAWN BY: CHKD: APPR: IKOSHY	QUALITY SYMBOLS ∇=0 ∇=0 ∇=0	GENERAL TOLERANCES (UNLESS SPECIFIED): mm INCH		DIMENSION STYLE MM ONLY	SCALE 2:1	DESIGN UNITS METRIC	THIRD ANGLE PROJECTION
		4 PLACES # --- # --- 3 PLACES # --- # --- 2 PLACES # --- # --- 1 PLACE # --- # --- 0 PLACE # --- # ---	DRAWN BY: SKRAJENDRANA DATE: 2011/02/14 CHECKED BY: MVANSLAMBROU DATE: 2011/02/14 APPROVED BY:	MATERIAL NO. SEE BOM TABLE	DOCUMENT NO. SD-34566-001	SHEET NO. 1 OF 59	

MX123
66/73/80CKT
HRNS CONN ASSY
molex

THIS DRAWING CONTAINS INFORMATION THAT IS PROPRIETARY TO MOLEX INCORPORATED AND SHOULD NOT BE USED WITHOUT WRITTEN PERMISSION

80 CKT

WIRE DRESS OPTION 0

HOUSING ONLY, SHOWN FOR CLARITY

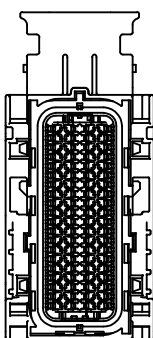
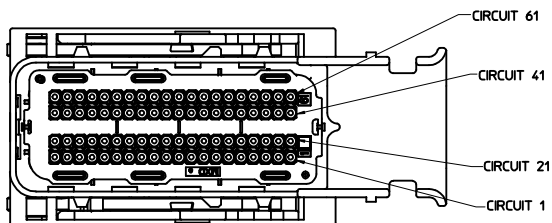

KEY G

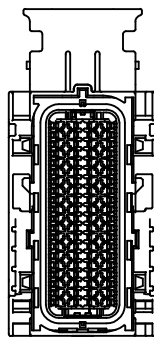

KEY H

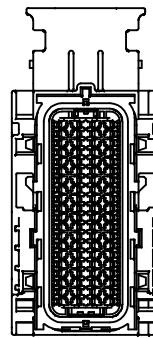

KEY J

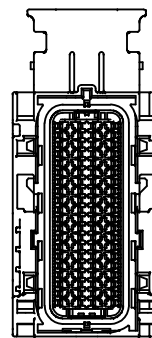

KEY K

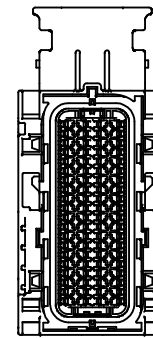

KEY L

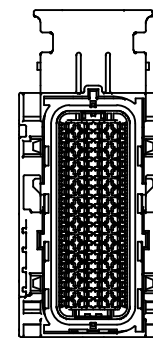

KEY M

WIRE DRESS OPTION 9

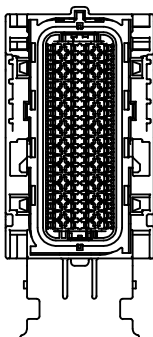
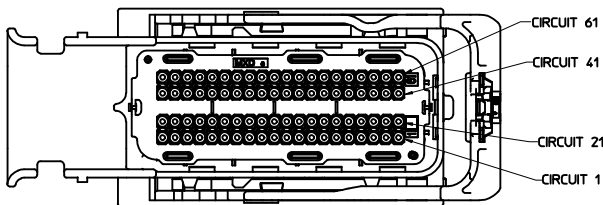

KEY G

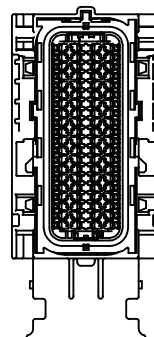

KEY H

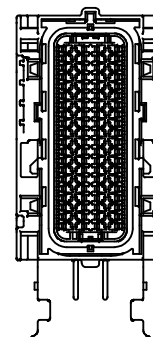

KEY J

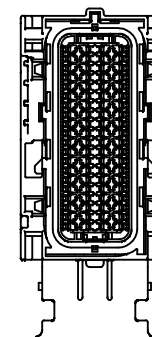

KEY K

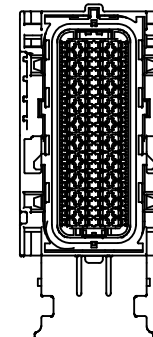

KEY L

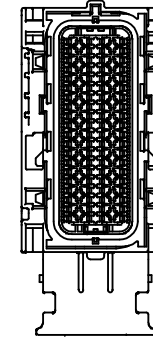

KEY M

ENTER DESCRIPTION EC NO: UAU2013-0662 DRAWN BY: CHYK APPR: WOSHY REV: F86	2012/11/01 DESCRIPTION	QUALITY SYMBOLS ▽=0 ▽=0 ▽=0	GENERAL TOLERANCES (UNLESS SPECIFIED) mm INCH 4 PLACES +--- +--- 3 PLACES +--- +--- 2 PLACES +--- +--- 1 PLACE +--- +--- 0 PLACE +--- +---	DIMENSION STYLE MM ONLY	SCALE 1.5:1	DESIGN UNITS METRIC	THIRD ANGLE PROJECTION
	DRAWN BY: SKRAJENDRANA DATE: 2011/02/14	CHECKED BY: MYANSLAMBROU DATE: 2011/02/14	APPROVED BY:	MATERIAL NO.	DOCUMENT NO.	TITLE MX123 66/73/80CKT HRNS CONN ASSY	SHEET NO. 2 OF 59
	SEE BOM TABLE	SD-34566-001	THIS DRAWING CONTAINS INFORMATION THAT IS PROPRIETARY TO MOLEX INCORPORATED AND SHOULD NOT BE USED WITHOUT WRITTEN PERMISSION				
	ANGULAR ±---° DRAFT WHERE APPLICABLE MUST REMAIN WITHIN DIMENSIONS						

73 CKT

WIRE DRESS OPTION 0

HOUSING ONLY, SHOWN FOR CLARITY

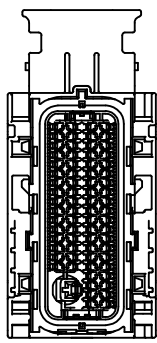
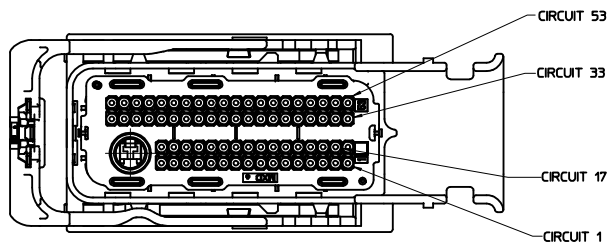

KEY A

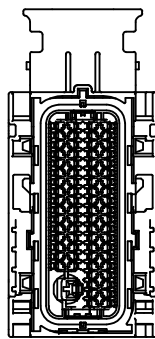

KEY B

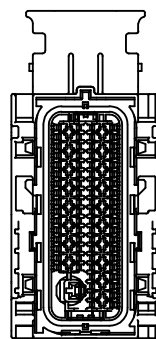

KEY O

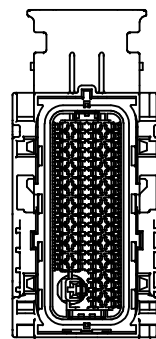

KEY D

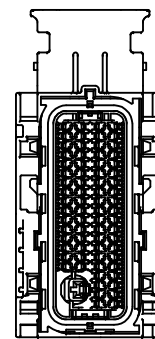

KEY E

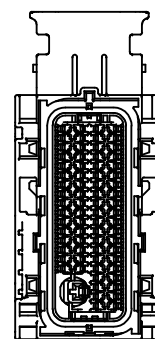

KEY F

WIRE DRESS OPTION 9

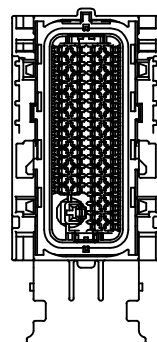
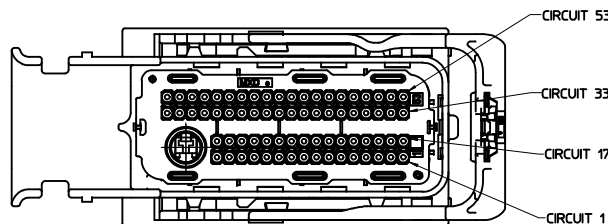

KEY A

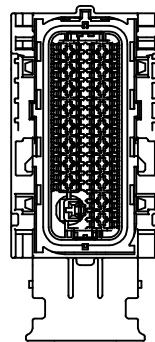

KEY B

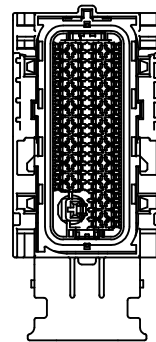

KEY O

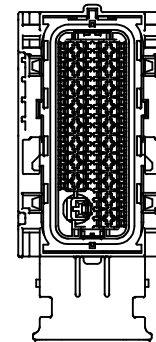

KEY D

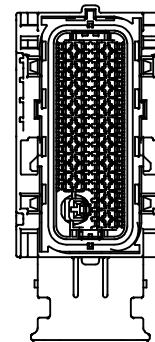

KEY E

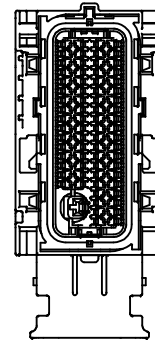

KEY F

ENTER DESCRIPTION TEC NO: UAU2013-0662 DRAWN BY: CHKD APPR: KOSHY DATE: 2012/11/21 REV: 06	QUALITY SYMBOLS	GENERAL TOLERANCES (UNLESS SPECIFIED)		DIMENSION STYLE	SCALE	DESIGN UNITS	THIRD ANGLE PROJECTION		
	▽=0	mm	INCH	MM ONLY	1.5:1	METRIC			
	▽=0	4 PLACES	3 PLACES	3 PLACES	2 PLACES	1 PLACE	0 PLACE		
	▽=0	ANGULAR ±		DRAFT WHERE APPLICABLE MUST REMAIN WITHIN DIMENSIONS		MATERIAL NO. SEE BOM TABLE		DOCUMENT NO. SD-34566-001	
DRAWN BY: SKRAJENDRANA 2011/02/14 CHECKED BY: MVANSLAMBROU 2011/02/14 APPROVED BY:				DATE: 2011/02/14 DATE: 2011/02/14 DATE:				TITLE: MX123 66/73/80CKT HRNS CONN ASSY molex SHEET NO. 3 OF 59	

66 CKT

WIRE DRESS OPTION 0

HOUSING ONLY, SHOWN FOR CLARITY

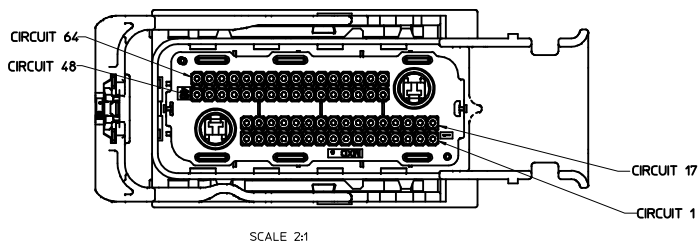

SCALE 2:1

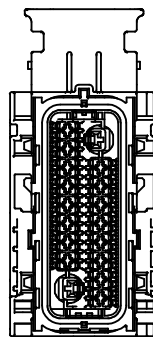

KEY A

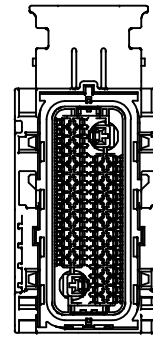

KEY C

WIRE DRESS OPTION 9

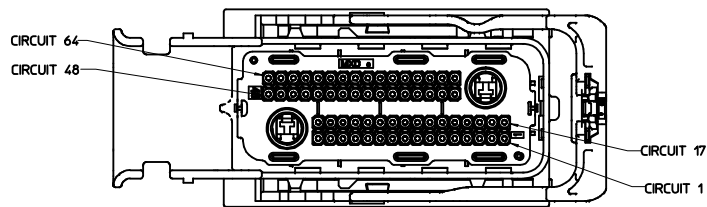

SCALE 2:1

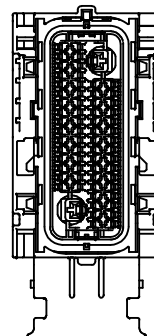

KEY A

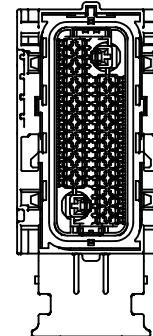

KEY C

ENTER DESCRIPTION EC NO: UAU2013-0662 DRAWN BY: CHYD CHKD: APPR: WOSHY REV:	QUALITY SYMBOLS ∇=0 ∇=0 ∇=0	GENERAL TOLERANCES (UNLESS SPECIFIED) mm INCH 4 PLACES +---+---+---+--- 3 PLACES +---+---+---+--- 2 PLACES +---+---+---+--- 1 PLACE +---+---+---+--- 0 PLACE +---+---+---+--- ANGULAR ±---° DRAFT WHERE APPLICABLE MUST REMAIN WITHIN DIMENSIONS	DIMENSION STYLE MM ONLY DRAWN BY: SKRAJENDRANA CHECKED BY: MYANSLAMBROU APPROVED BY:	SCALE 1.5:1 DESIGN UNITS METRIC THIRD ANGLE PROJECTION	DATE: 2012/11/21 DATE: 2011/02/14 DATE: 2011/02/14 DATE:	TITLE MX123 66/73/80CKT HRNS CONN ASSY molex	MATERIAL NO. SEE BOM TABLE	DOCUMENT NO. SD-34566-001	SHEET NO. 4 OF 59
	THIS DRAWING CONTAINS INFORMATION THAT IS PROPRIETARY TO MOLEX INCORPORATED AND SHOULD NOT BE USED WITHOUT WRITTEN PERMISSION								
	SIZE D								
	T86								

STATUS	GM PART #	MATERIAL #	PART / MATERIAL REVISION	WIRE DRESS OPTION	KEY OPTION	COLOR (TPA)	NUMBERS INDICATE CAVITIES OPEN FOR CIRCUITS
AVAILABLE	12582677	34566-003	G	0	A	BLACK	
AVAILABLE	12582678	34566-0203	G	0	B	ST GRY	72 71 70 69 68 67 66 65 64 63 62 61 60 59 58 57 56 55 54 53
AVAILABLE	12615654	34566-0303	G	0	C	BLUE	52 51 50 49 48 47 46 45 44 43 42 41 40 39 38 37 36 35 34 33
ACTIVE	12615660	34566-0403	G	0	D	BROWN	73 32 31 30 29 28 27 26 25 24 23 22 21 20 19 18 17
ACTIVE	12615661	34566-0503	G	0	E	GREEN	16 15 14 13 12 11 10 9 8 7 6 5 4 3 2 1
ACTIVE	12615662	34566-0603	G	0	F	NATURAL	
AVAILABLE	12588057	34566-0703	G	0	G	BLUE	
AVAILABLE	12588058	34566-0803	G	0	H	ST GRY	80 79 78 77 76 75 74 73 72 71 70 69 68 67 66 65 64 63 62 61
ACTIVE	12615658	34566-0903	G	0	J	BLACK	60 59 58 57 56 55 54 53 52 51 50 49 48 47 46 45 44 43 42 41
ACTIVE	TBD	34566-1003	G	0	K	BROWN	40 39 38 37 36 35 34 33 32 31 30 29 28 27 26 25 24 23 22 21
ACTIVE	TBD	34566-1103	G	0	L	GREEN	20 19 18 17 16 15 14 13 12 11 10 9 8 7 6 5 4 3 2 1
ACTIVE	TBD	34566-1203	G	0	M	NATURAL	
AVAILABLE	12603596	34566-1303	G	9	A	BLACK	
AVAILABLE	12603597	34566-1403	G	9	B	ST GRY	72 71 70 69 68 67 66 65 64 63 62 61 60 59 58 57 56 55 54 53
AVAILABLE	12615655	34566-1503	G	9	C	BLUE	52 51 50 49 48 47 46 45 44 43 42 41 40 39 38 37 36 35 34 33
ACTIVE	12615663	34566-1603	G	9	D	BROWN	73 32 31 30 29 28 27 26 25 24 23 22 21 20 19 18 17
ACTIVE	12615664	34566-1703	G	9	E	GREEN	16 15 14 13 12 11 10 9 8 7 6 5 4 3 2 1
ACTIVE	12615665	34566-1803	G	9	F	NATURAL	
AVAILABLE	12603598	34566-1903	G	9	G	BLUE	
AVAILABLE	12603599	34566-2003	G	9	H	ST GRY	80 79 78 77 76 75 74 73 72 71 70 69 68 67 66 65 64 63 62 61
ACTIVE	12615659	34566-2103	G	9	J	BLACK	60 59 58 57 56 55 54 53 52 51 50 49 48 47 46 45 44 43 42 41
ACTIVE	TBD	34566-2203	G	9	K	BROWN	40 39 38 37 36 35 34 33 32 31 30 29 28 27 26 25 24 23 22 21
ACTIVE	TBD	34566-2303	G	9	L	GREEN	20 19 18 17 16 15 14 13 12 11 10 9 8 7 6 5 4 3 2 1
ACTIVE	TBD	34566-2403	G	9	M	NATURAL	
ACTIVE	TBD	34822-0013	A	0	A	BLACK	64 63 62 61 60 59 58 57 56 55 54 53 52 51 50 49 66
ACTIVE	TBD	34822-0033	A	0	C	BLUE	48 47 46 45 44 43 42 41 40 39 38 37 36 35 34 33 65
ACTIVE	TBD	34822-0023	A	9	A	BLACK	32 31 30 29 28 27 26 25 24 23 22 21 20 19 18 17
ACTIVE	TBD	34822-0043	A	9	C	BLUE	16 15 14 13 12 11 10 9 8 7 6 5 4 3 2 1
N/A	N/A	N/A	N/A	N/A	N/A	N/A	73
AVAILABLE	NOT APPLICABLE	34566-2503	G	0	A	BLACK	72 71 69 68 67 66 64 63 62 59 56 53
							50 48 46 44 43 42 39 36 35 33
							73 32 30 29 27 23 20 17
							14 13 12 11 9 8 5 4 3 2 1

SEE NEXT PAGE FOR ADDITIONAL NUMBERS

ENTER DESCRIPTION EC NO: UAU2013-0662 DRAWN BY: 2012/11/01 CHKD: 2012/11/21 APPR: IKOSHY REV:	QUALITY SYMBOLS	GENERAL TOLERANCES (UNLESS SPECIFIED)	DIMENSION STYLE	SCALE	DESIGN UNITS	THIRD ANGLE PROJECTION
	▽=0	4 PLACES ±--- INCH	MM ONLY		METRIC	
	▽=0	3 PLACES ±--- INCH	DRAWN BY: SKRAJENDRANA	DATE: 2011/02/14	TITLE: MX123	
	▽=0	2 PLACES ±--- INCH	CHECKED BY: MYANSLAMBROU	DATE: 2011/02/14	HRNS CONN ASSY	
	1 PLACE ±--- INCH	APPROVED BY:	DATE:			
	0 PLACE ±--- INCH					
	ANGULAR ±---°	DRAFT WHERE APPLICABLE MUST REMAIN WITHIN DIMENSIONS	MATERIAL NO. SEE BOM TABLE	DOCUMENT NO. SD-34566-001	SHEET NO. 5 OF 59	
			THIS DRAWING CONTAINS INFORMATION THAT IS PROPRIETARY TO MOLEX INCORPORATED AND SHOULD NOT BE USED WITHOUT WRITTEN PERMISSION			

STATUS	GM PART #	MATERIAL #	PART/MATERIAL REVISION	WIRE DRESS OPTION	KEY OPTION	COLOR (TPA)	NUMBERS INDICATE CAVITIES OPEN FOR CIRCUITS																																																																																	
AVAILABLE	NOT APPLICABLE	34566-2603	G	0	B	ST GR	<table border="1"> <tr><td></td><td></td><td></td><td></td><td>67</td><td>66</td><td>65</td><td></td><td></td><td></td><td></td><td></td><td>59</td><td>57</td><td>55</td><td>53</td></tr> <tr><td></td><td></td><td>49</td><td>48</td><td>47</td><td></td><td></td><td>44</td><td></td><td></td><td></td><td></td><td>39</td><td>37</td><td>35</td><td>33</td></tr> <tr><td>73</td><td></td><td></td><td></td><td></td><td></td><td>29</td><td>28</td><td></td><td></td><td></td><td></td><td>23</td><td>21</td><td></td><td></td></tr> <tr><td></td><td></td><td></td><td></td><td></td><td></td><td></td><td></td><td></td><td></td><td></td><td></td><td>7</td><td></td><td></td><td></td></tr> </table>					67	66	65						59	57	55	53			49	48	47			44					39	37	35	33	73						29	28					23	21															7																				
				67	66	65						59	57	55	53																																																																									
		49	48	47			44					39	37	35	33																																																																									
73						29	28					23	21																																																																											
												7																																																																												
AVAILABLE	NOT APPLICABLE	34566-2703	G	0	B	ST GR	<table border="1"> <tr><td></td><td></td><td></td><td></td><td></td><td></td><td>65</td><td></td><td></td><td></td><td></td><td></td><td>59</td><td>57</td><td>55</td><td>53</td></tr> <tr><td></td><td></td><td>49</td><td>48</td><td>47</td><td></td><td></td><td>44</td><td></td><td></td><td></td><td></td><td>39</td><td>37</td><td>35</td><td>33</td></tr> <tr><td>73</td><td></td><td></td><td></td><td></td><td></td><td>29</td><td>28</td><td></td><td></td><td></td><td></td><td>23</td><td>21</td><td></td><td></td></tr> <tr><td></td><td></td><td></td><td></td><td></td><td></td><td></td><td></td><td></td><td></td><td></td><td></td><td>7</td><td></td><td></td><td></td></tr> </table>							65						59	57	55	53			49	48	47			44					39	37	35	33	73						29	28					23	21															7																				
						65						59	57	55	53																																																																									
		49	48	47			44					39	37	35	33																																																																									
73						29	28					23	21																																																																											
												7																																																																												
AVAILABLE	NOT APPLICABLE	34566-2803	G	0	H	ST GR	<table border="1"> <tr><td></td><td></td><td></td><td></td><td></td><td></td><td></td><td></td><td></td><td></td><td></td><td></td><td></td><td></td><td></td><td></td></tr> <tr><td></td><td></td><td></td><td></td><td></td><td></td><td></td><td></td><td></td><td></td><td></td><td></td><td></td><td></td><td></td><td></td></tr> <tr><td></td><td></td><td></td><td></td><td></td><td></td><td></td><td></td><td></td><td></td><td></td><td></td><td></td><td></td><td></td><td></td></tr> <tr><td></td><td></td><td></td><td></td><td></td><td></td><td></td><td></td><td></td><td></td><td></td><td></td><td></td><td></td><td></td><td></td></tr> </table>																																																																																	
AVAILABLE	NOT APPLICABLE	34566-2903	G	0	A	BLACK	<table border="1"> <tr><td>72</td><td>71</td><td>70</td><td>69</td><td>68</td><td>67</td><td>66</td><td></td><td>64</td><td>63</td><td>62</td><td>61</td><td></td><td>59</td><td></td><td></td><td>55</td><td>54</td><td>53</td></tr> <tr><td>52</td><td>51</td><td></td><td>49</td><td>48</td><td></td><td></td><td></td><td>44</td><td>43</td><td>42</td><td>41</td><td></td><td>39</td><td></td><td></td><td></td><td>35</td><td>34</td><td>33</td></tr> <tr><td></td><td></td><td></td><td>32</td><td>31</td><td></td><td></td><td>29</td><td></td><td>27</td><td></td><td>25</td><td>24</td><td>23</td><td></td><td></td><td></td><td>19</td><td>18</td><td>17</td></tr> <tr><td>73</td><td></td><td></td><td></td><td>16</td><td></td><td></td><td>13</td><td>12</td><td>11</td><td></td><td>9</td><td>8</td><td>7</td><td>6</td><td>5</td><td>4</td><td>3</td><td>2</td><td>1</td></tr> </table>	72	71	70	69	68	67	66		64	63	62	61		59			55	54	53	52	51		49	48				44	43	42	41		39				35	34	33				32	31			29		27		25	24	23				19	18	17	73				16			13	12	11		9	8	7	6	5	4	3	2	1		
72	71	70	69	68	67	66		64	63	62	61		59			55	54	53																																																																						
52	51		49	48				44	43	42	41		39				35	34	33																																																																					
			32	31			29		27		25	24	23				19	18	17																																																																					
73				16			13	12	11		9	8	7	6	5	4	3	2	1																																																																					
AVAILABLE	NOT APPLICABLE	34566-3003	G	0	A	BLACK	<table border="1"> <tr><td>72</td><td>71</td><td>70</td><td>69</td><td>68</td><td>67</td><td>66</td><td></td><td>64</td><td>63</td><td>62</td><td></td><td>60</td><td>59</td><td>58</td><td>57</td><td>56</td><td>55</td><td>54</td><td>53</td></tr> <tr><td>52</td><td>51</td><td>50</td><td>49</td><td>48</td><td>47</td><td>46</td><td></td><td>44</td><td>43</td><td>42</td><td>41</td><td>40</td><td>39</td><td>38</td><td>37</td><td>36</td><td>35</td><td>34</td><td>33</td></tr> <tr><td></td><td></td><td></td><td>32</td><td>31</td><td>30</td><td>29</td><td>28</td><td>27</td><td></td><td>25</td><td>24</td><td>23</td><td>22</td><td>21</td><td>20</td><td>19</td><td>18</td><td>17</td><td></td></tr> <tr><td>73</td><td></td><td></td><td>16</td><td>15</td><td>14</td><td>13</td><td>12</td><td>11</td><td></td><td>9</td><td>8</td><td>7</td><td>6</td><td>5</td><td>4</td><td>3</td><td>2</td><td>1</td><td></td></tr> </table>	72	71	70	69	68	67	66		64	63	62		60	59	58	57	56	55	54	53	52	51	50	49	48	47	46		44	43	42	41	40	39	38	37	36	35	34	33				32	31	30	29	28	27		25	24	23	22	21	20	19	18	17		73			16	15	14	13	12	11		9	8	7	6	5	4	3	2	1		
72	71	70	69	68	67	66		64	63	62		60	59	58	57	56	55	54	53																																																																					
52	51	50	49	48	47	46		44	43	42	41	40	39	38	37	36	35	34	33																																																																					
			32	31	30	29	28	27		25	24	23	22	21	20	19	18	17																																																																						
73			16	15	14	13	12	11		9	8	7	6	5	4	3	2	1																																																																						
AVAILABLE	NOT APPLICABLE	34566-3103	G	0	B	ST GR	<table border="1"> <tr><td></td><td></td><td></td><td></td><td></td><td></td><td></td><td></td><td>65</td><td></td><td>62</td><td></td><td>59</td><td>57</td><td>55</td><td>53</td></tr> <tr><td></td><td></td><td>49</td><td>48</td><td></td><td></td><td>46</td><td></td><td></td><td>42</td><td></td><td>39</td><td>37</td><td>35</td><td>33</td></tr> <tr><td>73</td><td></td><td></td><td></td><td></td><td></td><td>29</td><td></td><td></td><td>26</td><td></td><td>23</td><td>21</td><td></td><td>18</td></tr> <tr><td></td><td></td><td></td><td>15</td><td></td><td></td><td></td><td></td><td></td><td>9</td><td>8</td><td>7</td><td></td><td>4</td><td>3</td></tr> </table>									65		62		59	57	55	53			49	48			46			42		39	37	35	33	73						29			26		23	21		18				15						9	8	7		4	3																				
								65		62		59	57	55	53																																																																									
		49	48			46			42		39	37	35	33																																																																										
73						29			26		23	21		18																																																																										
			15						9	8	7		4	3																																																																										
AVAILABLE	NOT APPLICABLE	34566-3203	G	0	B	ST GR	<table border="1"> <tr><td></td><td></td><td></td><td></td><td>67</td><td></td><td></td><td></td><td></td><td></td><td></td><td></td><td>60</td><td>59</td><td>58</td><td>57</td><td>56</td><td>55</td><td>53</td></tr> <tr><td></td><td>50</td><td>49</td><td>48</td><td></td><td>46</td><td></td><td></td><td></td><td></td><td></td><td></td><td>39</td><td>38</td><td>37</td><td></td><td>35</td><td>34</td><td>33</td></tr> <tr><td>73</td><td></td><td></td><td></td><td></td><td></td><td>29</td><td></td><td></td><td></td><td></td><td></td><td>23</td><td>22</td><td>21</td><td></td><td></td><td>18</td><td></td></tr> <tr><td></td><td></td><td></td><td>16</td><td>15</td><td>14</td><td></td><td></td><td></td><td></td><td></td><td></td><td>7</td><td>6</td><td>5</td><td>4</td><td>3</td><td></td><td></td></tr> </table>					67								60	59	58	57	56	55	53		50	49	48		46							39	38	37		35	34	33	73						29						23	22	21			18					16	15	14							7	6	5	4	3							
				67								60	59	58	57	56	55	53																																																																						
	50	49	48		46							39	38	37		35	34	33																																																																						
73						29						23	22	21			18																																																																							
			16	15	14							7	6	5	4	3																																																																								
AVAILABLE	NOT APPLICABLE	34566-3303	G	0	B	ST GR	<table border="1"> <tr><td></td><td></td><td>50</td><td>49</td><td>48</td><td></td><td>46</td><td></td><td></td><td></td><td></td><td></td><td></td><td>59</td><td>58</td><td>57</td><td>56</td><td>55</td><td>53</td></tr> <tr><td></td><td></td><td></td><td></td><td></td><td></td><td></td><td></td><td></td><td></td><td></td><td></td><td></td><td>39</td><td>38</td><td>37</td><td></td><td>35</td><td>34</td><td>33</td></tr> <tr><td>73</td><td></td><td></td><td></td><td></td><td></td><td>29</td><td></td><td></td><td></td><td></td><td></td><td></td><td>23</td><td>22</td><td>21</td><td></td><td></td><td>18</td><td></td></tr> <tr><td></td><td></td><td></td><td>16</td><td>15</td><td>14</td><td></td><td></td><td></td><td></td><td></td><td></td><td></td><td>7</td><td>6</td><td>5</td><td>4</td><td>3</td><td></td><td></td></tr> </table>			50	49	48		46							59	58	57	56	55	53														39	38	37		35	34	33	73						29							23	22	21			18					16	15	14								7	6	5	4	3				
		50	49	48		46							59	58	57	56	55	53																																																																						
													39	38	37		35	34	33																																																																					
73						29							23	22	21			18																																																																						
			16	15	14								7	6	5	4	3																																																																							
AVAILABLE	NOT APPLICABLE	34566-3403					SEE 34566-3003																																																																																	
AVAILABLE	NOT APPLICABLE	34566-3503	G	0	A	BLACK	<table border="1"> <tr><td>72</td><td>71</td><td></td><td>69</td><td>68</td><td>67</td><td>66</td><td></td><td>64</td><td>63</td><td>62</td><td></td><td>60</td><td>59</td><td></td><td></td><td></td><td></td><td></td><td></td></tr> <tr><td>52</td><td></td><td></td><td>49</td><td>48</td><td></td><td>46</td><td></td><td>44</td><td>43</td><td>42</td><td></td><td>40</td><td>39</td><td></td><td></td><td></td><td></td><td>35</td><td>33</td></tr> <tr><td></td><td></td><td></td><td></td><td></td><td></td><td></td><td>29</td><td></td><td>27</td><td></td><td>24</td><td>23</td><td></td><td></td><td></td><td></td><td></td><td></td><td>17</td></tr> <tr><td>73</td><td></td><td></td><td></td><td></td><td></td><td></td><td>14</td><td>13</td><td>12</td><td>11</td><td></td><td>9</td><td>8</td><td>7</td><td>6</td><td>5</td><td>4</td><td>3</td><td>2</td><td>1</td></tr> </table>	72	71		69	68	67	66		64	63	62		60	59							52			49	48		46		44	43	42		40	39					35	33								29		27		24	23							17	73							14	13	12	11		9	8	7	6	5	4	3	2	1
72	71		69	68	67	66		64	63	62		60	59																																																																											
52			49	48		46		44	43	42		40	39					35	33																																																																					
							29		27		24	23							17																																																																					
73							14	13	12	11		9	8	7	6	5	4	3	2	1																																																																				

SEE NEXT PAGE FOR ADDITIONAL NUMBERS

ENTER DESCRIPTION EC NO: UAU2013-0662 DRAWN BY: CHKD CHCK: APPR: IKOSHY 2012/11/21 DESCRIPTION:	QUALITY SYMBOLS	GENERAL TOLERANCES (UNLESS SPECIFIED)	DIMENSION STYLE	SCALE	DESIGN UNITS	THIRD ANGLE PROJECTION	
	∇=0 ∇=0 ∇=0	4 PLACES ± --- + --- 3 PLACES ± --- + --- 2 PLACES ± --- + --- 1 PLACE ± --- + --- 0 PLACE ± --- + ---	mm INCH --- --- --- --- --- --- --- ---	MM ONLY DRAWN BY: SKRAJENDRANA DATE: 2011/02/14 CHECKED BY: MYANSLAMBROU DATE: 2011/02/14 APPROVED BY:	TITLE:	METRIC	☉
	ANGULAR ± ---° DRAFT WHERE APPLICABLE MUST REMAIN WITHIN DIMENSIONS	MATERIAL NO: SEE BOM TABLE	DOCUMENT NO: SD-34566-001	SHEET NO: 6 OF 59			
	THIS DRAWING CONTAINS INFORMATION THAT IS PROPRIETARY TO MOLEX INCORPORATED AND SHOULD NOT BE USED WITHOUT WRITTEN PERMISSION						

MX123
66/73/80CKT
HRNS CONN ASSY

molex

STATUS	GM PART #	MATERIAL #	PART/ MATERIAL REVISION	WIRE DRESS OPTION	KEY OPTION	COLOR (TPA)	NUMBERS INDICATE CAVITIES OPEN FOR CIRCUITS																																																																																
AVAILABLE	NOT APPLICABLE	34566-4403	G	0	A	BLACK	<table border="1"> <tr><td>72</td><td>71</td><td>70</td><td>69</td><td>68</td><td>67</td><td>66</td><td>65</td><td>64</td><td>63</td><td>61</td><td>59</td><td>58</td><td>57</td><td>56</td><td></td><td></td><td></td><td></td><td></td></tr> <tr><td></td><td></td><td>50</td><td>49</td><td>48</td><td>47</td><td></td><td></td><td></td><td></td><td>41</td><td></td><td></td><td>38</td><td>37</td><td>36</td><td>34</td><td>33</td><td></td><td></td></tr> <tr><td></td><td>73</td><td></td><td>32</td><td>31</td><td>30</td><td>29</td><td>28</td><td>27</td><td></td><td></td><td>24</td><td>23</td><td></td><td></td><td>20</td><td>19</td><td>18</td><td></td><td></td></tr> <tr><td></td><td></td><td></td><td>16</td><td></td><td></td><td>13</td><td>12</td><td>11</td><td>10</td><td>9</td><td></td><td></td><td>6</td><td>4</td><td></td><td></td><td></td><td></td><td></td></tr> </table>	72	71	70	69	68	67	66	65	64	63	61	59	58	57	56								50	49	48	47					41			38	37	36	34	33				73		32	31	30	29	28	27			24	23			20	19	18						16			13	12	11	10	9			6	4					
72	71	70	69	68	67	66	65	64	63	61	59	58	57	56																																																																									
		50	49	48	47					41			38	37	36	34	33																																																																						
	73		32	31	30	29	28	27			24	23			20	19	18																																																																						
			16			13	12	11	10	9			6	4																																																																									
AVAILABLE	NOT APPLICABLE	34566-4503	G	0	H	ST GRAY	<table border="1"> <tr><td></td><td>79</td><td>78</td><td>77</td><td>76</td><td>75</td><td>74</td><td>73</td><td>72</td><td>71</td><td>70</td><td>69</td><td>68</td><td></td><td>66</td><td>65</td><td>64</td><td>63</td><td>61</td><td></td></tr> <tr><td>60</td><td>59</td><td>58</td><td>57</td><td>56</td><td></td><td></td><td>53</td><td></td><td></td><td>50</td><td></td><td></td><td></td><td></td><td></td><td></td><td>44</td><td>43</td><td>41</td></tr> <tr><td>40</td><td>39</td><td>38</td><td>37</td><td></td><td>35</td><td>34</td><td>33</td><td>32</td><td></td><td>30</td><td>29</td><td></td><td>27</td><td>26</td><td></td><td>24</td><td>23</td><td>22</td><td>21</td></tr> <tr><td>20</td><td>19</td><td>18</td><td>17</td><td></td><td></td><td></td><td>13</td><td>12</td><td>11</td><td></td><td></td><td>8</td><td></td><td>6</td><td>5</td><td></td><td>3</td><td>2</td><td></td></tr> </table>		79	78	77	76	75	74	73	72	71	70	69	68		66	65	64	63	61		60	59	58	57	56			53			50							44	43	41	40	39	38	37		35	34	33	32		30	29		27	26		24	23	22	21	20	19	18	17				13	12	11			8		6	5		3	2	
	79	78	77	76	75	74	73	72	71	70	69	68		66	65	64	63	61																																																																					
60	59	58	57	56			53			50							44	43	41																																																																				
40	39	38	37		35	34	33	32		30	29		27	26		24	23	22	21																																																																				
20	19	18	17				13	12	11			8		6	5		3	2																																																																					
AVAILABLE	NOT APPLICABLE	34566-4603	G	0	H	ST GRAY	<table border="1"> <tr><td></td><td>79</td><td>78</td><td>77</td><td>76</td><td>75</td><td>74</td><td>73</td><td>72</td><td>71</td><td>70</td><td>69</td><td>68</td><td></td><td>66</td><td>65</td><td>64</td><td>63</td><td>61</td><td></td></tr> <tr><td>60</td><td>59</td><td>58</td><td>57</td><td>56</td><td></td><td></td><td>53</td><td></td><td></td><td>50</td><td></td><td></td><td></td><td></td><td></td><td></td><td>44</td><td>43</td><td>41</td></tr> <tr><td>40</td><td>39</td><td>38</td><td>37</td><td></td><td>35</td><td>34</td><td>33</td><td>32</td><td></td><td>30</td><td>29</td><td></td><td>27</td><td>26</td><td></td><td>24</td><td>23</td><td>22</td><td>21</td></tr> <tr><td>20</td><td>19</td><td>18</td><td>17</td><td></td><td></td><td></td><td>13</td><td>12</td><td>11</td><td></td><td></td><td>8</td><td></td><td>6</td><td>5</td><td></td><td>3</td><td>2</td><td></td></tr> </table>		79	78	77	76	75	74	73	72	71	70	69	68		66	65	64	63	61		60	59	58	57	56			53			50							44	43	41	40	39	38	37		35	34	33	32		30	29		27	26		24	23	22	21	20	19	18	17				13	12	11			8		6	5		3	2	
	79	78	77	76	75	74	73	72	71	70	69	68		66	65	64	63	61																																																																					
60	59	58	57	56			53			50							44	43	41																																																																				
40	39	38	37		35	34	33	32		30	29		27	26		24	23	22	21																																																																				
20	19	18	17				13	12	11			8		6	5		3	2																																																																					
AVAILABLE	NOT APPLICABLE	34566-4703	G	0	B	ST GRAY	<table border="1"> <tr><td></td><td></td><td></td><td></td><td>67</td><td>66</td><td>65</td><td>64</td><td></td><td></td><td></td><td></td><td>59</td><td>58</td><td>57</td><td>55</td><td>53</td><td></td><td></td><td></td></tr> <tr><td></td><td></td><td></td><td>49</td><td>48</td><td>47</td><td></td><td>44</td><td></td><td></td><td></td><td></td><td>39</td><td>38</td><td>37</td><td>35</td><td>33</td><td></td><td></td><td></td></tr> <tr><td></td><td>73</td><td></td><td></td><td></td><td></td><td>29</td><td></td><td></td><td></td><td></td><td></td><td>23</td><td>22</td><td>21</td><td></td><td></td><td></td><td></td><td></td></tr> <tr><td></td><td></td><td></td><td></td><td></td><td></td><td></td><td>12</td><td></td><td></td><td>9</td><td></td><td>7</td><td></td><td></td><td></td><td></td><td></td><td></td><td></td></tr> </table>					67	66	65	64					59	58	57	55	53							49	48	47		44					39	38	37	35	33					73					29						23	22	21													12			9		7							
				67	66	65	64					59	58	57	55	53																																																																							
			49	48	47		44					39	38	37	35	33																																																																							
	73					29						23	22	21																																																																									
							12			9		7																																																																											
AVAILABLE	NOT APPLICABLE	34566-4803	G	0	A	BLACK	<table border="1"> <tr><td>72</td><td>71</td><td></td><td>69</td><td>68</td><td>67</td><td>66</td><td></td><td>64</td><td>63</td><td>62</td><td>61</td><td>59</td><td></td><td></td><td></td><td></td><td></td><td>35</td><td>33</td></tr> <tr><td></td><td></td><td></td><td></td><td>48</td><td></td><td></td><td></td><td>44</td><td>42</td><td>41</td><td>39</td><td></td><td></td><td></td><td></td><td></td><td></td><td></td><td>17</td></tr> <tr><td></td><td>73</td><td></td><td></td><td></td><td></td><td>29</td><td></td><td>27</td><td>25</td><td>23</td><td></td><td></td><td></td><td></td><td>5</td><td>4</td><td>3</td><td>2</td><td>1</td></tr> <tr><td></td><td></td><td></td><td></td><td></td><td></td><td>13</td><td>12</td><td>11</td><td>9</td><td>8</td><td></td><td></td><td></td><td></td><td></td><td></td><td></td><td></td><td></td></tr> </table>	72	71		69	68	67	66		64	63	62	61	59						35	33					48				44	42	41	39								17		73					29		27	25	23					5	4	3	2	1							13	12	11	9	8									
72	71		69	68	67	66		64	63	62	61	59						35	33																																																																				
				48				44	42	41	39								17																																																																				
	73					29		27	25	23					5	4	3	2	1																																																																				
						13	12	11	9	8																																																																													
AVAILABLE	NOT APPLICABLE	34566-4903	G	0	A	BLACK	<table border="1"> <tr><td>72</td><td>71</td><td>70</td><td>69</td><td>68</td><td></td><td>66</td><td>65</td><td>64</td><td>63</td><td>62</td><td>61</td><td>59</td><td>58</td><td>57</td><td>56</td><td>55</td><td></td><td></td><td></td></tr> <tr><td>52</td><td>51</td><td>50</td><td>49</td><td></td><td>47</td><td></td><td></td><td>44</td><td>43</td><td>41</td><td></td><td></td><td>38</td><td>37</td><td>36</td><td>35</td><td>34</td><td>33</td><td></td></tr> <tr><td></td><td>73</td><td></td><td></td><td></td><td>32</td><td>31</td><td>30</td><td>29</td><td>28</td><td>27</td><td></td><td>24</td><td>23</td><td></td><td></td><td>20</td><td>19</td><td>18</td><td>17</td></tr> <tr><td></td><td></td><td></td><td></td><td></td><td>16</td><td>15</td><td>14</td><td>13</td><td>12</td><td>11</td><td>10</td><td>9</td><td></td><td></td><td></td><td></td><td></td><td></td><td>2</td></tr> </table>	72	71	70	69	68		66	65	64	63	62	61	59	58	57	56	55				52	51	50	49		47			44	43	41			38	37	36	35	34	33			73				32	31	30	29	28	27		24	23			20	19	18	17						16	15	14	13	12	11	10	9							2
72	71	70	69	68		66	65	64	63	62	61	59	58	57	56	55																																																																							
52	51	50	49		47			44	43	41			38	37	36	35	34	33																																																																					
	73				32	31	30	29	28	27		24	23			20	19	18	17																																																																				
					16	15	14	13	12	11	10	9							2																																																																				
AVAILABLE	NOT APPLICABLE	34566-5003	G	0	H	ST GRAY	<table border="1"> <tr><td></td><td>79</td><td>78</td><td>77</td><td>76</td><td>75</td><td>74</td><td>73</td><td>72</td><td>71</td><td>70</td><td>69</td><td>68</td><td></td><td>66</td><td>65</td><td>64</td><td>63</td><td>61</td><td></td></tr> <tr><td>60</td><td>59</td><td>58</td><td>57</td><td>56</td><td></td><td></td><td>53</td><td>52</td><td></td><td>50</td><td></td><td></td><td></td><td></td><td></td><td></td><td>44</td><td>43</td><td>41</td></tr> <tr><td>40</td><td>39</td><td>38</td><td>37</td><td></td><td>35</td><td>34</td><td>33</td><td>32</td><td></td><td>30</td><td>29</td><td></td><td>27</td><td>26</td><td></td><td></td><td></td><td>22</td><td>21</td></tr> <tr><td>20</td><td>19</td><td>18</td><td>17</td><td>16</td><td></td><td>14</td><td>13</td><td>12</td><td>11</td><td>10</td><td>9</td><td>8</td><td></td><td>6</td><td>5</td><td></td><td>3</td><td>2</td><td></td></tr> </table>		79	78	77	76	75	74	73	72	71	70	69	68		66	65	64	63	61		60	59	58	57	56			53	52		50							44	43	41	40	39	38	37		35	34	33	32		30	29		27	26				22	21	20	19	18	17	16		14	13	12	11	10	9	8		6	5		3	2	
	79	78	77	76	75	74	73	72	71	70	69	68		66	65	64	63	61																																																																					
60	59	58	57	56			53	52		50							44	43	41																																																																				
40	39	38	37		35	34	33	32		30	29		27	26				22	21																																																																				
20	19	18	17	16		14	13	12	11	10	9	8		6	5		3	2																																																																					
AVAILABLE	NOT APPLICABLE	34566-5103	G	0	B	ST GRAY	<table border="1"> <tr><td></td><td></td><td></td><td></td><td>67</td><td>66</td><td>65</td><td></td><td></td><td></td><td></td><td></td><td>59</td><td></td><td>57</td><td>55</td><td>53</td><td></td><td></td><td></td></tr> <tr><td></td><td></td><td></td><td>49</td><td>48</td><td>47</td><td>46</td><td></td><td>44</td><td></td><td></td><td></td><td>39</td><td>37</td><td>37</td><td>35</td><td>33</td><td></td><td></td><td></td></tr> <tr><td></td><td>73</td><td></td><td></td><td></td><td></td><td>29</td><td>28</td><td></td><td></td><td></td><td></td><td>23</td><td>21</td><td></td><td></td><td></td><td></td><td></td><td></td></tr> <tr><td></td><td></td><td></td><td></td><td></td><td></td><td></td><td></td><td></td><td></td><td></td><td></td><td>7</td><td></td><td></td><td></td><td></td><td></td><td></td><td></td></tr> </table>					67	66	65						59		57	55	53							49	48	47	46		44				39	37	37	35	33					73					29	28					23	21																			7							
				67	66	65						59		57	55	53																																																																							
			49	48	47	46		44				39	37	37	35	33																																																																							
	73					29	28					23	21																																																																										
												7																																																																											
SEE NEXT PAGE FOR ADDITIONAL NUMBERS																																																																																							

ENTER DESCRIPTION ELEC NO: UAU2013-0662 DRAWN BY: 2012/11/01 CHKD: APPR: IKOSHY 2012/11/21 REV: 186	QUALITY SYMBOLS	GENERAL TOLERANCES (UNLESS SPECIFIED)	DIMENSION STYLE	SCALE	DESIGN UNITS	THIRD ANGLE PROJECTION
	▽=0	4 PLACES ± --- INCH	MM ONLY		METRIC	
	▽=0	3 PLACES ± ---	DRAWN BY: SKRAJENDRANA 2011/02/14	DATE		TITLE
	▽=0	2 PLACES ± ---	CHECKED BY: MVANSLAMBROU 2011/02/14	DATE		
	1 PLACE ± ---	APPROVED BY: DATE				
	0 PLACE ± ---					
	ANGULAR ± ---					
	DRAFT WHERE APPLICABLE MUST REMAIN WITHIN DIMENSIONS					
			MATERIAL NO.		DOCUMENT NO.	SHEET NO.
			SEE BOM TABLE		SD-34566-001	8 OF 59
			THIS DRAWING CONTAINS INFORMATION THAT IS PROPRIETARY TO MOLEX INCORPORATED AND SHOULD NOT BE USED WITHOUT WRITTEN PERMISSION			

STATUS	GM PART #	MATERIAL #	PART/MATERIAL REVISION	WIRE DRESS OPTION	KEY OPTION	COLOR (TPA)	NUMBERS INDICATE CAVITIES OPEN FOR CIRCUITS																																																																						
AVAILABLE	NOT APPLICABLE	34566-5203	G	0	A	BLACK	<table border="1"> <tr><td>72</td><td>71</td><td>69</td><td>68</td><td>67</td><td>66</td><td>64</td><td>63</td><td>62</td><td>59</td><td>58</td><td>57</td><td>56</td><td>54</td><td>53</td></tr> <tr><td>52</td><td>51</td><td>50</td><td>49</td><td>48</td><td>47</td><td>46</td><td>44</td><td>43</td><td>42</td><td>39</td><td>38</td><td>37</td><td>36</td><td>35</td><td>34</td><td>33</td></tr> <tr><td>73</td><td></td><td></td><td>32</td><td>31</td><td>30</td><td>29</td><td>27</td><td></td><td>24</td><td>23</td><td>22</td><td>21</td><td>20</td><td>19</td><td>17</td><td></td></tr> <tr><td></td><td></td><td></td><td>15</td><td>14</td><td>13</td><td>12</td><td>11</td><td>9</td><td>8</td><td>7</td><td>6</td><td>5</td><td>4</td><td>3</td><td>2</td><td>1</td></tr> </table>	72	71	69	68	67	66	64	63	62	59	58	57	56	54	53	52	51	50	49	48	47	46	44	43	42	39	38	37	36	35	34	33	73			32	31	30	29	27		24	23	22	21	20	19	17					15	14	13	12	11	9	8	7	6	5	4	3	2	1				
72	71	69	68	67	66	64	63	62	59	58	57	56	54	53																																																															
52	51	50	49	48	47	46	44	43	42	39	38	37	36	35	34	33																																																													
73			32	31	30	29	27		24	23	22	21	20	19	17																																																														
			15	14	13	12	11	9	8	7	6	5	4	3	2	1																																																													
AVAILABLE	NOT APPLICABLE	34566-5303	G	0	B	ST GRY	<table border="1"> <tr><td></td><td></td><td></td><td></td><td></td><td></td><td>65</td><td>64</td><td></td><td></td><td>59</td><td>57</td><td>55</td><td>53</td><td></td></tr> <tr><td></td><td></td><td>50</td><td>49</td><td>48</td><td>46</td><td></td><td></td><td></td><td></td><td>39</td><td>37</td><td>35</td><td>33</td><td></td></tr> <tr><td>73</td><td></td><td></td><td>32</td><td></td><td>29</td><td></td><td></td><td></td><td></td><td>23</td><td>21</td><td></td><td></td><td></td></tr> <tr><td></td><td></td><td></td><td>15</td><td></td><td></td><td></td><td></td><td></td><td></td><td>7</td><td>6</td><td>5</td><td>4</td><td>3</td><td></td><td></td></tr> </table>							65	64			59	57	55	53				50	49	48	46					39	37	35	33		73			32		29					23	21							15							7	6	5	4	3										
						65	64			59	57	55	53																																																																
		50	49	48	46					39	37	35	33																																																																
73			32		29					23	21																																																																		
			15							7	6	5	4	3																																																															
AVAILABLE	NOT APPLICABLE	34566-5403	G	0	B	ST GRY	<table border="1"> <tr><td></td><td></td><td></td><td></td><td></td><td></td><td>65</td><td></td><td></td><td></td><td>59</td><td>58</td><td>57</td><td>56</td><td>55</td><td>53</td><td></td></tr> <tr><td></td><td></td><td>50</td><td>49</td><td>48</td><td>46</td><td>45</td><td></td><td></td><td></td><td>39</td><td>38</td><td>37</td><td>35</td><td>34</td><td>33</td><td></td></tr> <tr><td>73</td><td></td><td></td><td></td><td></td><td>29</td><td></td><td></td><td></td><td></td><td>23</td><td>22</td><td>21</td><td></td><td>18</td><td></td><td></td></tr> <tr><td></td><td></td><td></td><td>16</td><td>15</td><td>14</td><td></td><td></td><td></td><td></td><td>7</td><td>6</td><td>5</td><td>4</td><td>3</td><td></td><td></td></tr> </table>							65				59	58	57	56	55	53				50	49	48	46	45				39	38	37	35	34	33		73					29					23	22	21		18						16	15	14					7	6	5	4	3				
						65				59	58	57	56	55	53																																																														
		50	49	48	46	45				39	38	37	35	34	33																																																														
73					29					23	22	21		18																																																															
			16	15	14					7	6	5	4	3																																																															
AVAILABLE	NOT APPLICABLE	34566-5503	G	0	A	BLACK	<table border="1"> <tr><td>72</td><td>71</td><td>69</td><td>68</td><td>67</td><td>66</td><td>64</td><td>63</td><td>62</td><td>60</td><td>59</td><td></td><td></td><td></td><td></td><td></td><td></td></tr> <tr><td>52</td><td></td><td>49</td><td>48</td><td>46</td><td>44</td><td>43</td><td>42</td><td>40</td><td>39</td><td></td><td></td><td></td><td>35</td><td>33</td><td></td><td></td></tr> <tr><td>73</td><td></td><td></td><td>32</td><td></td><td>29</td><td>27</td><td>26</td><td>24</td><td>23</td><td></td><td></td><td></td><td></td><td>17</td><td></td><td></td></tr> <tr><td></td><td></td><td></td><td></td><td></td><td>14</td><td>13</td><td>12</td><td>11</td><td>10</td><td>9</td><td>8</td><td>7</td><td>6</td><td>5</td><td>4</td><td>3</td><td>2</td><td>1</td></tr> </table>	72	71	69	68	67	66	64	63	62	60	59							52		49	48	46	44	43	42	40	39				35	33			73			32		29	27	26	24	23					17								14	13	12	11	10	9	8	7	6	5	4	3	2	1
72	71	69	68	67	66	64	63	62	60	59																																																																			
52		49	48	46	44	43	42	40	39				35	33																																																															
73			32		29	27	26	24	23					17																																																															
					14	13	12	11	10	9	8	7	6	5	4	3	2	1																																																											
AVAILABLE	NOT APPLICABLE	34566-5603						SEE 34566-2503																																																																					
AVAILABLE	NOT APPLICABLE	34566-5703	G	0	B	ST GRY	<table border="1"> <tr><td></td><td></td><td></td><td></td><td>68</td><td></td><td></td><td></td><td></td><td></td><td>59</td><td>57</td><td>55</td><td>53</td><td></td></tr> <tr><td></td><td></td><td></td><td>49</td><td>48</td><td>46</td><td></td><td></td><td></td><td></td><td>39</td><td>37</td><td>35</td><td>33</td><td></td></tr> <tr><td>73</td><td></td><td></td><td></td><td></td><td>29</td><td></td><td></td><td></td><td></td><td>23</td><td>21</td><td></td><td>18</td><td>17</td></tr> <tr><td></td><td></td><td></td><td></td><td></td><td></td><td>12</td><td>11</td><td>10</td><td></td><td>7</td><td></td><td></td><td></td><td></td><td></td><td></td><td></td></tr> </table>					68						59	57	55	53					49	48	46					39	37	35	33		73					29					23	21		18	17							12	11	10		7														
				68						59	57	55	53																																																																
			49	48	46					39	37	35	33																																																																
73					29					23	21		18	17																																																															
						12	11	10		7																																																																			
AVAILABLE	NOT APPLICABLE	34566-5803	G	0	B	ST GRY	<table border="1"> <tr><td></td><td></td><td></td><td>49</td><td>48</td><td>47</td><td>65</td><td></td><td></td><td></td><td>59</td><td>57</td><td>55</td><td>53</td><td></td></tr> <tr><td></td><td></td><td></td><td></td><td></td><td>29</td><td></td><td></td><td></td><td></td><td>39</td><td>37</td><td>35</td><td>33</td><td></td></tr> <tr><td>73</td><td></td><td></td><td></td><td></td><td></td><td>12</td><td></td><td></td><td></td><td>23</td><td>21</td><td></td><td>17</td><td></td></tr> <tr><td></td><td></td><td></td><td></td><td></td><td></td><td></td><td></td><td></td><td></td><td>7</td><td></td><td></td><td></td><td></td><td></td><td></td><td></td></tr> </table>				49	48	47	65				59	57	55	53							29					39	37	35	33		73						12				23	21		17												7														
			49	48	47	65				59	57	55	53																																																																
					29					39	37	35	33																																																																
73						12				23	21		17																																																																
										7																																																																			
AVAILABLE	NOT APPLICABLE	34566-5903	G	0	A	BLACK	<table border="1"> <tr><td>72</td><td>71</td><td>69</td><td>68</td><td>67</td><td>66</td><td>64</td><td>63</td><td>62</td><td>59</td><td></td><td></td><td></td><td></td><td></td><td></td><td></td></tr> <tr><td></td><td></td><td></td><td>48</td><td></td><td></td><td>44</td><td>43</td><td>42</td><td>39</td><td></td><td></td><td></td><td>35</td><td>33</td><td></td><td></td></tr> <tr><td>73</td><td></td><td></td><td>32</td><td></td><td>29</td><td>27</td><td></td><td></td><td>23</td><td></td><td></td><td></td><td></td><td>17</td><td></td><td></td></tr> <tr><td></td><td></td><td></td><td></td><td></td><td></td><td>13</td><td>12</td><td>11</td><td>9</td><td>8</td><td></td><td></td><td>5</td><td>4</td><td>3</td><td>2</td><td>1</td></tr> </table>	72	71	69	68	67	66	64	63	62	59											48			44	43	42	39				35	33			73			32		29	27			23					17									13	12	11	9	8			5	4	3	2	1	
72	71	69	68	67	66	64	63	62	59																																																																				
			48			44	43	42	39				35	33																																																															
73			32		29	27			23					17																																																															
						13	12	11	9	8			5	4	3	2	1																																																												
SEE NEXT PAGE FOR ADDITIONAL NUMBERS																																																																													

ENTER DESCRIPTION EC NO: UAU2013-0662 DRAWN BY: 2012/11/01 CHKD: APPR:VKOSHY 2012/11/21 REV:	QUALITY SYMBOLS	GENERAL TOLERANCES (UNLESS SPECIFIED)	DIMENSION STYLE	SCALE	DESIGN UNITS	THIRD ANGLE PROJECTION	
	∇=0 ∇=0 ∇=0	4 PLACES ± --- INCH 3 PLACES ± --- INCH 2 PLACES ± --- INCH 1 PLACE ± --- INCH 0 PLACE ± --- INCH	mm INCH mm INCH mm INCH mm INCH	MM ONLY DRAWN BY: SKRAJENDRANA 2011/02/14 CHECKED BY: MYANSLAMBROU 2011/02/14 APPROVED BY:	DATE: 2011/02/14 DATE: 2011/02/14 DATE:	METRIC	TITLE: MX123 66/73/80CKT HRNS CONN ASSY
	ANGULAR ± ---° DRAFT WHERE APPLICABLE MUST REMAIN WITHIN DIMENSIONS	SEE BOM TABLE	MATERIAL NO. DOCUMENT NO. SD-34566-001	SHEET NO. 9 OF 59	THIS DRAWING CONTAINS INFORMATION THAT IS PROPRIETARY TO MOLEX INCORPORATED AND SHOULD NOT BE USED WITHOUT WRITTEN PERMISSION		
	moxle						

STATUS	GM PART #	MATERIAL #	PART/MATERIAL REVISION	WIRE DRESS OPTION	KEY OPTION	COLOR (TPA)	NUMBERS INDICATE CAVITIES OPEN FOR CIRCUITS																																																																																							
AVAILABLE	NOT APPLICABLE	34566-6003	G	0	B	ST GRAY	<table border="1"> <tr><td></td><td></td><td></td><td></td><td>67</td><td>66</td><td>65</td><td></td><td></td><td></td><td></td><td></td><td></td><td>59</td><td>57</td><td>55</td><td>53</td></tr> <tr><td></td><td></td><td>49</td><td>48</td><td>47</td><td></td><td></td><td></td><td></td><td></td><td></td><td></td><td></td><td>39</td><td>37</td><td>35</td><td>33</td></tr> <tr><td>73</td><td></td><td></td><td></td><td></td><td></td><td></td><td></td><td></td><td></td><td></td><td></td><td></td><td>23</td><td>21</td><td></td><td></td></tr> <tr><td></td><td></td><td></td><td></td><td></td><td></td><td></td><td></td><td></td><td></td><td></td><td></td><td></td><td>7</td><td></td><td></td><td></td></tr> </table>					67	66	65							59	57	55	53			49	48	47									39	37	35	33	73													23	21																7																						
				67	66	65							59	57	55	53																																																																														
		49	48	47									39	37	35	33																																																																														
73													23	21																																																																																
													7																																																																																	
AVAILABLE	NOT APPLICABLE	34566-6103	G	0	B	ST GRAY	<table border="1"> <tr><td></td><td></td><td></td><td></td><td>67</td><td>66</td><td>65</td><td></td><td></td><td></td><td></td><td></td><td></td><td>59</td><td>57</td><td>55</td><td>53</td></tr> <tr><td></td><td></td><td>49</td><td>48</td><td>47</td><td></td><td></td><td></td><td></td><td></td><td></td><td></td><td></td><td>39</td><td>37</td><td>35</td><td>33</td></tr> <tr><td>73</td><td></td><td></td><td></td><td></td><td></td><td></td><td></td><td></td><td></td><td></td><td></td><td></td><td>23</td><td>21</td><td></td><td></td></tr> <tr><td></td><td></td><td></td><td></td><td></td><td></td><td></td><td></td><td></td><td></td><td></td><td></td><td></td><td>9</td><td>7</td><td></td><td></td></tr> </table>					67	66	65							59	57	55	53			49	48	47									39	37	35	33	73													23	21																9	7																					
				67	66	65							59	57	55	53																																																																														
		49	48	47									39	37	35	33																																																																														
73													23	21																																																																																
													9	7																																																																																
AVAILABLE	NOT APPLICABLE	34566-6203	G	0	A	BLACK	<table border="1"> <tr><td></td><td>71</td><td>70</td><td>69</td><td>68</td><td></td><td></td><td></td><td>65</td><td>64</td><td>63</td><td></td><td>61</td><td>59</td><td>57</td><td>56</td><td></td><td></td></tr> <tr><td>52</td><td>51</td><td>50</td><td>49</td><td>47</td><td></td><td></td><td></td><td></td><td></td><td></td><td></td><td>41</td><td></td><td></td><td>38</td><td>37</td><td>36</td><td>34</td><td>33</td></tr> <tr><td>73</td><td></td><td></td><td></td><td></td><td></td><td></td><td></td><td></td><td></td><td></td><td></td><td></td><td></td><td></td><td>24</td><td>23</td><td></td><td>20</td><td>19</td><td>18</td></tr> <tr><td></td><td></td><td></td><td></td><td></td><td></td><td></td><td></td><td></td><td></td><td></td><td></td><td></td><td></td><td></td><td></td><td></td><td></td><td></td><td></td><td></td><td>1</td></tr> </table>		71	70	69	68				65	64	63		61	59	57	56			52	51	50	49	47								41			38	37	36	34	33	73															24	23		20	19	18																						1						
	71	70	69	68				65	64	63		61	59	57	56																																																																															
52	51	50	49	47								41			38	37	36	34	33																																																																											
73															24	23		20	19	18																																																																										
																					1																																																																									
AVAILABLE	NOT APPLICABLE	34566-6303	G	0	A	BLACK	<table border="1"> <tr><td></td><td>71</td><td>70</td><td>69</td><td>68</td><td></td><td></td><td></td><td>65</td><td>64</td><td>63</td><td></td><td>61</td><td>59</td><td>57</td><td>56</td><td></td><td></td></tr> <tr><td>52</td><td>51</td><td>50</td><td>49</td><td>47</td><td></td><td></td><td></td><td></td><td></td><td></td><td></td><td>41</td><td></td><td></td><td>38</td><td>37</td><td>36</td><td>34</td><td>33</td></tr> <tr><td>73</td><td></td><td></td><td></td><td></td><td></td><td></td><td></td><td></td><td></td><td></td><td></td><td></td><td></td><td></td><td>24</td><td>23</td><td></td><td>20</td><td>19</td><td>18</td></tr> <tr><td></td><td></td><td></td><td></td><td></td><td></td><td></td><td></td><td></td><td></td><td></td><td></td><td></td><td></td><td></td><td></td><td></td><td></td><td></td><td></td><td></td><td>1</td></tr> </table>		71	70	69	68				65	64	63		61	59	57	56			52	51	50	49	47								41			38	37	36	34	33	73															24	23		20	19	18																						1						
	71	70	69	68				65	64	63		61	59	57	56																																																																															
52	51	50	49	47								41			38	37	36	34	33																																																																											
73															24	23		20	19	18																																																																										
																					1																																																																									
AVAILABLE	NOT APPLICABLE	34566-6403	G	0	A	BLACK	<table border="1"> <tr><td></td><td>71</td><td></td><td>69</td><td>68</td><td></td><td></td><td></td><td>65</td><td>64</td><td>63</td><td></td><td>61</td><td>59</td><td>58</td><td>56</td><td></td><td></td></tr> <tr><td>52</td><td></td><td>50</td><td>49</td><td>47</td><td></td><td></td><td></td><td></td><td></td><td></td><td></td><td>41</td><td></td><td></td><td>38</td><td>37</td><td>36</td><td>34</td><td>33</td></tr> <tr><td>73</td><td></td><td></td><td></td><td></td><td></td><td></td><td></td><td></td><td></td><td></td><td></td><td></td><td></td><td></td><td>24</td><td>23</td><td></td><td>20</td><td>19</td><td>18</td></tr> <tr><td></td><td></td><td></td><td></td><td></td><td></td><td></td><td></td><td></td><td></td><td></td><td></td><td></td><td></td><td></td><td></td><td></td><td></td><td></td><td></td><td></td><td>1</td></tr> </table>		71		69	68				65	64	63		61	59	58	56			52		50	49	47								41			38	37	36	34	33	73															24	23		20	19	18																						1						
	71		69	68				65	64	63		61	59	58	56																																																																															
52		50	49	47								41			38	37	36	34	33																																																																											
73															24	23		20	19	18																																																																										
																					1																																																																									
AVAILABLE	NOT APPLICABLE	34566-6503	G	0	A	BLACK	<table border="1"> <tr><td></td><td>71</td><td></td><td>69</td><td>68</td><td></td><td></td><td></td><td>65</td><td>64</td><td>63</td><td></td><td>61</td><td>59</td><td>58</td><td>56</td><td></td><td></td></tr> <tr><td>52</td><td></td><td>50</td><td>49</td><td>47</td><td></td><td></td><td></td><td></td><td></td><td></td><td></td><td>41</td><td></td><td></td><td>38</td><td>37</td><td>36</td><td>34</td><td>33</td></tr> <tr><td>73</td><td></td><td></td><td></td><td></td><td></td><td></td><td></td><td></td><td></td><td></td><td></td><td></td><td></td><td></td><td>24</td><td>23</td><td></td><td>20</td><td>19</td><td>18</td></tr> <tr><td></td><td></td><td></td><td></td><td></td><td></td><td></td><td></td><td></td><td></td><td></td><td></td><td></td><td></td><td></td><td></td><td></td><td></td><td></td><td></td><td></td><td>1</td></tr> </table>		71		69	68				65	64	63		61	59	58	56			52		50	49	47								41			38	37	36	34	33	73															24	23		20	19	18																						1						
	71		69	68				65	64	63		61	59	58	56																																																																															
52		50	49	47								41			38	37	36	34	33																																																																											
73															24	23		20	19	18																																																																										
																					1																																																																									
AVAILABLE	NOT APPLICABLE	34566-6603	G	0	H	ST GRAY	<table border="1"> <tr><td></td><td>79</td><td>78</td><td>77</td><td>76</td><td>75</td><td>74</td><td>73</td><td>72</td><td>71</td><td>70</td><td>69</td><td>68</td><td></td><td>66</td><td>65</td><td>64</td><td>63</td><td>61</td><td></td><td></td></tr> <tr><td>60</td><td>59</td><td>58</td><td>57</td><td>56</td><td></td><td></td><td></td><td>53</td><td>52</td><td>50</td><td></td><td></td><td></td><td></td><td></td><td></td><td>44</td><td>43</td><td>41</td><td></td><td></td></tr> <tr><td>40</td><td>39</td><td>38</td><td>37</td><td></td><td>35</td><td>34</td><td>33</td><td>32</td><td></td><td>30</td><td>29</td><td></td><td></td><td>27</td><td>26</td><td></td><td></td><td></td><td>22</td><td>21</td><td></td></tr> <tr><td>20</td><td>19</td><td>18</td><td>17</td><td>16</td><td></td><td></td><td></td><td></td><td></td><td>13</td><td>12</td><td>11</td><td>10</td><td>9</td><td>8</td><td>6</td><td>5</td><td></td><td>3</td><td>2</td><td></td></tr> </table>		79	78	77	76	75	74	73	72	71	70	69	68		66	65	64	63	61			60	59	58	57	56				53	52	50							44	43	41			40	39	38	37		35	34	33	32		30	29			27	26				22	21		20	19	18	17	16						13	12	11	10	9	8	6	5		3	2	
	79	78	77	76	75	74	73	72	71	70	69	68		66	65	64	63	61																																																																												
60	59	58	57	56				53	52	50							44	43	41																																																																											
40	39	38	37		35	34	33	32		30	29			27	26				22	21																																																																										
20	19	18	17	16						13	12	11	10	9	8	6	5		3	2																																																																										
AVAILABLE	NOT APPLICABLE	34566-6703	G	0	H	ST GRAY	<table border="1"> <tr><td></td><td>79</td><td>78</td><td>77</td><td>76</td><td>75</td><td>74</td><td>73</td><td>72</td><td>71</td><td>70</td><td>69</td><td>68</td><td></td><td>66</td><td>65</td><td>64</td><td>63</td><td>61</td><td></td><td></td></tr> <tr><td>60</td><td>59</td><td>58</td><td>57</td><td>56</td><td></td><td></td><td></td><td>53</td><td></td><td>50</td><td></td><td></td><td></td><td></td><td></td><td></td><td>44</td><td>43</td><td>41</td><td></td><td></td></tr> <tr><td>40</td><td>39</td><td>38</td><td>37</td><td></td><td>35</td><td>34</td><td>33</td><td>32</td><td></td><td>30</td><td>29</td><td></td><td></td><td>27</td><td>26</td><td></td><td></td><td></td><td>22</td><td>21</td><td></td></tr> <tr><td>20</td><td>19</td><td>18</td><td>17</td><td></td><td></td><td></td><td></td><td></td><td></td><td>14</td><td>13</td><td>12</td><td>11</td><td>10</td><td>9</td><td>8</td><td>6</td><td>5</td><td></td><td>3</td><td>2</td></tr> </table>		79	78	77	76	75	74	73	72	71	70	69	68		66	65	64	63	61			60	59	58	57	56				53		50							44	43	41			40	39	38	37		35	34	33	32		30	29			27	26				22	21		20	19	18	17							14	13	12	11	10	9	8	6	5		3	2
	79	78	77	76	75	74	73	72	71	70	69	68		66	65	64	63	61																																																																												
60	59	58	57	56				53		50							44	43	41																																																																											
40	39	38	37		35	34	33	32		30	29			27	26				22	21																																																																										
20	19	18	17							14	13	12	11	10	9	8	6	5		3	2																																																																									

SEE NEXT PAGE FOR ADDITIONAL NUMBERS

ENTER DESCRIPTION EC NO: UAU2013-0662 DRAWN BY: [] CHKD: [] APPR: IKOSHY REV: []	QUALITY SYMBOLS ∇=0 ∇=0 ∇=0	GENERAL TOLERANCES (UNLESS SPECIFIED) mm INCH 4 PLACES ± --- ± --- 3 PLACES ± --- ± --- 2 PLACES ± --- ± --- 1 PLACE ± --- ± --- 0 PLACE ± --- ± ---	DIMENSION STYLE MM ONLY	SCALE DESIGN UNITS METRIC	THIRD ANGLE PROJECTION
	DRAWN BY: SKRAJENDRANA 2011/02/14 CHECKED BY: [] MYANSLAMBROU 2011/02/14 APPROVED BY: []		TITLE MX123 66/73/80CKT HRNS CONN ASSY		
	MATERIAL NO. SD-34566-001		DOCUMENT NO. SD-34566-001		
	DRAFT WHERE APPLICABLE MUST REMAIN WITHIN DIMENSIONS		SEE BOM TABLE THIS DRAWING CONTAINS INFORMATION THAT IS PROPRIETARY TO MOLEX INCORPORATED AND SHOULD NOT BE USED WITHOUT WRITTEN PERMISSION		

STATUS	GM PART #	MATERIAL #	PART/MATERIAL REVISION	WIRE DRESS OPTION	KEY OPTION	COLOR (TPA)	NUMBERS INDICATE CAVITIES OPEN FOR CIRCUITS																																																																																														
AVAILABLE	NOT APPLICABLE	34566-7603	G	0	B	ST GRAY	<table border="1"> <tr><td></td><td></td><td>69</td><td>68</td><td>66</td><td></td><td></td><td></td><td></td><td></td><td></td><td></td><td></td><td></td><td>59</td><td>57</td><td>55</td><td>53</td></tr> <tr><td></td><td></td><td>49</td><td>48</td><td>46</td><td>44</td><td></td><td></td><td></td><td></td><td></td><td></td><td></td><td></td><td>39</td><td>37</td><td>35</td><td>33</td></tr> <tr><td>73</td><td></td><td></td><td></td><td></td><td>29</td><td>28</td><td></td><td></td><td></td><td></td><td></td><td></td><td></td><td>23</td><td>21</td><td></td><td>18</td><td>17</td></tr> <tr><td></td><td></td><td></td><td></td><td></td><td>12</td><td>11</td><td>10</td><td></td><td></td><td></td><td></td><td></td><td></td><td>7</td><td></td><td></td><td></td><td></td></tr> </table>																		69	68	66										59	57	55	53			49	48	46	44									39	37	35	33	73					29	28								23	21		18	17						12	11	10							7									
		69	68	66										59	57	55	53																																																																																				
		49	48	46	44									39	37	35	33																																																																																				
73					29	28								23	21		18	17																																																																																			
					12	11	10							7																																																																																							
AVAILABLE	NOT APPLICABLE	34566-7703	G	0	A	BLACK	<table border="1"> <tr><td>72</td><td>71</td><td>70</td><td>69</td><td>68</td><td>67</td><td>66</td><td>64</td><td>63</td><td>62</td><td>60</td><td>59</td><td></td><td></td><td></td><td></td><td>55</td><td>54</td><td>53</td></tr> <tr><td>52</td><td></td><td>49</td><td>48</td><td></td><td></td><td></td><td>44</td><td>43</td><td>42</td><td>40</td><td>39</td><td></td><td></td><td></td><td></td><td>35</td><td>34</td><td>33</td></tr> <tr><td></td><td></td><td></td><td>32</td><td></td><td></td><td>29</td><td>27</td><td></td><td></td><td>24</td><td>23</td><td></td><td></td><td></td><td></td><td>19</td><td>18</td><td>17</td></tr> <tr><td>73</td><td></td><td></td><td>16</td><td></td><td></td><td>13</td><td>12</td><td>11</td><td></td><td>9</td><td>8</td><td>7</td><td>6</td><td>5</td><td>4</td><td>3</td><td>2</td><td>1</td></tr> </table>																72	71	70	69	68	67	66	64	63	62	60	59					55	54	53	52		49	48				44	43	42	40	39					35	34	33				32			29	27			24	23					19	18	17	73			16			13	12	11		9	8	7	6	5	4	3	2	1			
72	71	70	69	68	67	66	64	63	62	60	59					55	54	53																																																																																			
52		49	48				44	43	42	40	39					35	34	33																																																																																			
			32			29	27			24	23					19	18	17																																																																																			
73			16			13	12	11		9	8	7	6	5	4	3	2	1																																																																																			
AVAILABLE	NOT APPLICABLE	34566-7803	G	0	A	BLACK	<table border="1"> <tr><td>72</td><td>71</td><td>70</td><td>68</td><td>66</td><td>64</td><td>63</td><td>62</td><td>61</td><td>60</td><td>59</td><td></td><td></td><td></td><td></td><td>55</td><td>54</td><td>53</td></tr> <tr><td>52</td><td></td><td>49</td><td>48</td><td>46</td><td>44</td><td>43</td><td>42</td><td>40</td><td>39</td><td></td><td></td><td></td><td></td><td></td><td>35</td><td>34</td><td>33</td></tr> <tr><td></td><td></td><td></td><td>32</td><td></td><td>29</td><td>28</td><td>27</td><td></td><td></td><td>24</td><td>23</td><td></td><td></td><td></td><td>19</td><td>18</td><td>17</td></tr> <tr><td>73</td><td></td><td></td><td>16</td><td>14</td><td>13</td><td>12</td><td>11</td><td></td><td>9</td><td>8</td><td>7</td><td>6</td><td></td><td></td><td>3</td><td>2</td><td>1</td></tr> </table>																72	71	70	68	66	64	63	62	61	60	59					55	54	53	52		49	48	46	44	43	42	40	39						35	34	33				32		29	28	27			24	23				19	18	17	73			16	14	13	12	11		9	8	7	6			3	2	1							
72	71	70	68	66	64	63	62	61	60	59					55	54	53																																																																																				
52		49	48	46	44	43	42	40	39						35	34	33																																																																																				
			32		29	28	27			24	23				19	18	17																																																																																				
73			16	14	13	12	11		9	8	7	6			3	2	1																																																																																				
AVAILABLE	NOT APPLICABLE	34566-7903	G	0	B	ST GRAY	<table border="1"> <tr><td></td><td></td><td></td><td></td><td></td><td></td><td></td><td>64</td><td></td><td>61</td><td>59</td><td>57</td><td>55</td><td>53</td><td></td><td></td><td></td><td></td><td></td></tr> <tr><td></td><td></td><td></td><td></td><td></td><td></td><td></td><td></td><td></td><td>42</td><td>39</td><td></td><td>35</td><td>33</td><td></td><td></td><td></td><td></td><td></td></tr> <tr><td>73</td><td></td><td></td><td></td><td></td><td></td><td></td><td></td><td></td><td></td><td>23</td><td></td><td>20</td><td>19</td><td></td><td></td><td></td><td></td><td></td></tr> <tr><td></td><td></td><td></td><td></td><td></td><td></td><td>15</td><td></td><td></td><td></td><td></td><td></td><td>4</td><td>3</td><td>2</td><td>1</td><td></td><td></td><td></td></tr> </table>																							64		61	59	57	55	53															42	39		35	33						73										23		20	19												15						4	3	2	1						
							64		61	59	57	55	53																																																																																								
									42	39		35	33																																																																																								
73										23		20	19																																																																																								
						15						4	3	2	1																																																																																						
AVAILABLE	NOT APPLICABLE	34566-8003	G	0	A	BLACK	<table border="1"> <tr><td></td><td></td><td>69</td><td>68</td><td></td><td>65</td><td>64</td><td>63</td><td>61</td><td>60</td><td>59</td><td>58</td><td>56</td><td></td><td></td><td></td><td></td><td></td><td></td></tr> <tr><td>52</td><td>50</td><td>49</td><td>48</td><td>47</td><td></td><td></td><td></td><td>41</td><td></td><td></td><td>38</td><td>37</td><td>36</td><td></td><td></td><td>34</td><td>33</td><td></td></tr> <tr><td></td><td></td><td></td><td>32</td><td>31</td><td>30</td><td>29</td><td>28</td><td>27</td><td></td><td>24</td><td>23</td><td></td><td></td><td></td><td>20</td><td>19</td><td>18</td><td>17</td></tr> <tr><td>73</td><td></td><td></td><td>16</td><td></td><td></td><td>13</td><td>12</td><td>11</td><td>10</td><td>9</td><td></td><td></td><td></td><td></td><td></td><td></td><td></td><td>1</td></tr> </table>																		69	68		65	64	63	61	60	59	58	56							52	50	49	48	47				41			38	37	36			34	33					32	31	30	29	28	27		24	23				20	19	18	17	73			16			13	12	11	10	9								1			
		69	68		65	64	63	61	60	59	58	56																																																																																									
52	50	49	48	47				41			38	37	36			34	33																																																																																				
			32	31	30	29	28	27		24	23				20	19	18	17																																																																																			
73			16			13	12	11	10	9								1																																																																																			
AVAILABLE	NOT APPLICABLE	34566-8103	G	0	H	ST GRAY	<table border="1"> <tr><td></td><td></td><td>78</td><td></td><td></td><td></td><td>72</td><td>71</td><td>70</td><td>69</td><td>68</td><td>66</td><td>65</td><td>64</td><td>63</td><td>61</td><td></td><td></td><td></td></tr> <tr><td>60</td><td>59</td><td>58</td><td>57</td><td>56</td><td></td><td>53</td><td>52</td><td>50</td><td></td><td></td><td></td><td></td><td>44</td><td>43</td><td>41</td><td></td><td></td><td></td></tr> <tr><td>40</td><td></td><td></td><td>37</td><td>35</td><td>34</td><td>33</td><td>32</td><td>30</td><td>29</td><td>27</td><td>26</td><td>24</td><td>22</td><td>21</td><td></td><td></td><td></td><td></td></tr> <tr><td>20</td><td>19</td><td>18</td><td>17</td><td>16</td><td></td><td>13</td><td>12</td><td></td><td></td><td>8</td><td>6</td><td>5</td><td>3</td><td>2</td><td></td><td></td><td></td><td></td></tr> </table>																		78				72	71	70	69	68	66	65	64	63	61				60	59	58	57	56		53	52	50					44	43	41				40			37	35	34	33	32	30	29	27	26	24	22	21					20	19	18	17	16		13	12			8	6	5	3	2							
		78				72	71	70	69	68	66	65	64	63	61																																																																																						
60	59	58	57	56		53	52	50					44	43	41																																																																																						
40			37	35	34	33	32	30	29	27	26	24	22	21																																																																																							
20	19	18	17	16		13	12			8	6	5	3	2																																																																																							
AVAILABLE	NOT APPLICABLE	34566-8203	G	0	A	BLACK	<table border="1"> <tr><td></td><td></td><td>70</td><td></td><td>67</td><td>66</td><td></td><td></td><td></td><td></td><td></td><td>58</td><td>56</td><td>55</td><td>54</td><td></td><td></td><td></td><td></td></tr> <tr><td></td><td></td><td></td><td></td><td>47</td><td></td><td>44</td><td>43</td><td>42</td><td>41</td><td>39</td><td></td><td>37</td><td>36</td><td>34</td><td></td><td></td><td></td><td></td></tr> <tr><td>73</td><td></td><td></td><td></td><td>31</td><td>30</td><td></td><td></td><td>27</td><td>25</td><td>24</td><td></td><td>21</td><td>20</td><td>19</td><td>18</td><td></td><td></td><td></td></tr> <tr><td></td><td></td><td></td><td></td><td></td><td></td><td>13</td><td></td><td></td><td></td><td></td><td>6</td><td>5</td><td>4</td><td>3</td><td>2</td><td>1</td><td></td><td></td></tr> </table>																		70		67	66						58	56	55	54									47		44	43	42	41	39		37	36	34					73				31	30			27	25	24		21	20	19	18										13					6	5	4	3	2	1					
		70		67	66						58	56	55	54																																																																																							
				47		44	43	42	41	39		37	36	34																																																																																							
73				31	30			27	25	24		21	20	19	18																																																																																						
						13					6	5	4	3	2	1																																																																																					
AVAILABLE	NOT APPLICABLE	34566-8303	G	0	A	BLACK	<table border="1"> <tr><td>72</td><td>71</td><td>69</td><td>68</td><td>67</td><td>66</td><td>64</td><td>63</td><td>62</td><td></td><td>59</td><td>58</td><td>57</td><td>56</td><td></td><td>54</td><td>53</td><td></td><td></td></tr> <tr><td>52</td><td>51</td><td>50</td><td>49</td><td>48</td><td>47</td><td>46</td><td>44</td><td>43</td><td>42</td><td></td><td>39</td><td>38</td><td>37</td><td>36</td><td>35</td><td>34</td><td>33</td><td></td><td></td></tr> <tr><td></td><td></td><td></td><td>32</td><td>31</td><td>30</td><td>29</td><td>27</td><td></td><td></td><td>24</td><td>23</td><td>22</td><td>21</td><td>20</td><td>19</td><td>17</td><td></td><td></td><td></td></tr> <tr><td>73</td><td></td><td></td><td>15</td><td>14</td><td>13</td><td>12</td><td>11</td><td></td><td>9</td><td>8</td><td>7</td><td>6</td><td>5</td><td>4</td><td>3</td><td>2</td><td>1</td><td></td><td></td></tr> </table>																72	71	69	68	67	66	64	63	62		59	58	57	56		54	53			52	51	50	49	48	47	46	44	43	42		39	38	37	36	35	34	33						32	31	30	29	27			24	23	22	21	20	19	17				73			15	14	13	12	11		9	8	7	6	5	4	3	2	1		
72	71	69	68	67	66	64	63	62		59	58	57	56		54	53																																																																																					
52	51	50	49	48	47	46	44	43	42		39	38	37	36	35	34	33																																																																																				
			32	31	30	29	27			24	23	22	21	20	19	17																																																																																					
73			15	14	13	12	11		9	8	7	6	5	4	3	2	1																																																																																				

SEE NEXT PAGE FOR ADDITIONAL NUMBERS

ENTER DESCRIPTION ELEC NO: UAU2013-0662 DRAWN BY: 2012/11/01 CHKD: APPR: IKOSHY REV: 186	QUALITY SYMBOLS ∇=0 ∇=0 ∇=0	GENERAL TOLERANCES (UNLESS SPECIFIED) mm INCH 4 PLACES ± --- ± --- 3 PLACES ± --- ± --- 2 PLACES ± --- ± --- 1 PLACE ± --- ± --- 0 PLACE ± --- ± ---	DIMENSION STYLE MM ONLY	SCALE DESIGN UNITS METRIC	THIRD ANGLE PROJECTION
	DRAWN BY: SKRAJENDRANA 2011/02/14 CHECKED BY: MYANSLAMBROU 2011/02/14 APPROVED BY:		DATE:		TITLE MX123 66/73/80CKT HRNS CONN ASSY
	MATERIAL NO.		DOCUMENT NO.		SHEET NO.
	SEE BOM TABLE		SD-34566-001		12 OF 59

STATUS	GM PART #	MATERIAL #	PART/MATERIAL REVISION	WIRE DRESS OPTION	KEY OPTION	COLOR (TPA)	NUMBERS INDICATE CAVITIES OPEN FOR CIRCUITS																																																																											
AVAILABLE	NOT APPLICABLE	34566-9203	G	0	A	BLACK	<table border="1"> <tr><td>72</td><td>71</td><td>70</td><td>69</td><td>68</td><td>67</td><td>66</td><td>64</td><td>63</td><td>62</td><td>60</td><td>59</td><td></td><td></td><td>55</td><td>54</td><td>53</td></tr> <tr><td>52</td><td></td><td></td><td>49</td><td>48</td><td></td><td></td><td>44</td><td>43</td><td>42</td><td>40</td><td>39</td><td>38</td><td></td><td>35</td><td>34</td><td>33</td></tr> <tr><td></td><td></td><td>73</td><td></td><td></td><td></td><td>30</td><td>29</td><td>28</td><td>27</td><td></td><td>24</td><td>23</td><td></td><td>19</td><td>18</td><td>17</td></tr> <tr><td></td><td></td><td></td><td>16</td><td></td><td></td><td>13</td><td>12</td><td>11</td><td></td><td>9</td><td>8</td><td>7</td><td>6</td><td>5</td><td>4</td><td>3</td><td>2</td><td>1</td></tr> </table>	72	71	70	69	68	67	66	64	63	62	60	59			55	54	53	52			49	48			44	43	42	40	39	38		35	34	33			73				30	29	28	27		24	23		19	18	17				16			13	12	11		9	8	7	6	5	4	3	2	1					
72	71	70	69	68	67	66	64	63	62	60	59			55	54	53																																																																		
52			49	48			44	43	42	40	39	38		35	34	33																																																																		
		73				30	29	28	27		24	23		19	18	17																																																																		
			16			13	12	11		9	8	7	6	5	4	3	2	1																																																																
AVAILABLE	NOT APPLICABLE	34566-9303	G	0	A	BLACK	<table border="1"> <tr><td>72</td><td>71</td><td></td><td>69</td><td>68</td><td>67</td><td>66</td><td>64</td><td>63</td><td>62</td><td></td><td>59</td><td>58</td><td>57</td><td>56</td><td>55</td><td>54</td><td>53</td></tr> <tr><td>52</td><td>51</td><td>50</td><td>49</td><td>48</td><td>47</td><td>46</td><td>44</td><td>43</td><td>42</td><td></td><td>39</td><td>38</td><td>37</td><td>36</td><td>35</td><td>34</td><td>33</td></tr> <tr><td></td><td></td><td>73</td><td></td><td>32</td><td>31</td><td>30</td><td>29</td><td>27</td><td></td><td></td><td>24</td><td>23</td><td>22</td><td>21</td><td>20</td><td>19</td><td>17</td></tr> <tr><td></td><td></td><td></td><td>16</td><td>15</td><td>14</td><td>13</td><td>12</td><td>11</td><td></td><td>9</td><td>8</td><td>7</td><td>6</td><td>5</td><td>4</td><td>3</td><td>2</td><td>1</td></tr> </table>	72	71		69	68	67	66	64	63	62		59	58	57	56	55	54	53	52	51	50	49	48	47	46	44	43	42		39	38	37	36	35	34	33			73		32	31	30	29	27			24	23	22	21	20	19	17				16	15	14	13	12	11		9	8	7	6	5	4	3	2	1		
72	71		69	68	67	66	64	63	62		59	58	57	56	55	54	53																																																																	
52	51	50	49	48	47	46	44	43	42		39	38	37	36	35	34	33																																																																	
		73		32	31	30	29	27			24	23	22	21	20	19	17																																																																	
			16	15	14	13	12	11		9	8	7	6	5	4	3	2	1																																																																
AVAILABLE	NOT APPLICABLE	34566-9403	G	0	B	ST GRY	<table border="1"> <tr><td></td><td></td><td></td><td>68</td><td>67</td><td>66</td><td>65</td><td></td><td></td><td></td><td></td><td>59</td><td>58</td><td>57</td><td></td><td></td><td>54</td><td>53</td></tr> <tr><td></td><td>51</td><td>50</td><td>49</td><td>48</td><td>46</td><td>45</td><td>43</td><td>42</td><td>41</td><td></td><td>40</td><td>39</td><td>38</td><td>37</td><td>35</td><td></td><td>33</td></tr> <tr><td></td><td></td><td>73</td><td></td><td>32</td><td>31</td><td>30</td><td></td><td></td><td>26</td><td></td><td>24</td><td>23</td><td>22</td><td></td><td>20</td><td></td><td></td></tr> <tr><td></td><td></td><td></td><td>16</td><td></td><td></td><td>13</td><td></td><td></td><td>10</td><td>9</td><td>8</td><td>7</td><td>6</td><td>5</td><td>4</td><td></td><td></td></tr> </table>				68	67	66	65					59	58	57			54	53		51	50	49	48	46	45	43	42	41		40	39	38	37	35		33			73		32	31	30			26		24	23	22		20						16			13			10	9	8	7	6	5	4					
			68	67	66	65					59	58	57			54	53																																																																	
	51	50	49	48	46	45	43	42	41		40	39	38	37	35		33																																																																	
		73		32	31	30			26		24	23	22		20																																																																			
			16			13			10	9	8	7	6	5	4																																																																			
AVAILABLE	NOT APPLICABLE	34566-9503	G	0	A	BLACK	<table border="1"> <tr><td>72</td><td>71</td><td>70</td><td>69</td><td>68</td><td></td><td></td><td>65</td><td>64</td><td>63</td><td>61</td><td>59</td><td>58</td><td>57</td><td>56</td><td></td><td></td><td></td></tr> <tr><td>52</td><td>51</td><td></td><td>49</td><td></td><td>47</td><td></td><td></td><td></td><td></td><td>41</td><td></td><td></td><td>38</td><td>37</td><td>36</td><td>34</td><td>33</td></tr> <tr><td></td><td></td><td>73</td><td></td><td>32</td><td>31</td><td>30</td><td>29</td><td>28</td><td>27</td><td></td><td>24</td><td>23</td><td></td><td></td><td>20</td><td>19</td><td>18</td><td>17</td></tr> <tr><td></td><td></td><td></td><td>16</td><td></td><td></td><td>13</td><td>12</td><td>11</td><td>10</td><td>9</td><td></td><td></td><td></td><td></td><td></td><td></td><td></td><td>1</td></tr> </table>	72	71	70	69	68			65	64	63	61	59	58	57	56				52	51		49		47					41			38	37	36	34	33			73		32	31	30	29	28	27		24	23			20	19	18	17				16			13	12	11	10	9								1	
72	71	70	69	68			65	64	63	61	59	58	57	56																																																																				
52	51		49		47					41			38	37	36	34	33																																																																	
		73		32	31	30	29	28	27		24	23			20	19	18	17																																																																
			16			13	12	11	10	9								1																																																																
AVAILABLE	NOT APPLICABLE	34566-9603	G	0	A	BLACK	<table border="1"> <tr><td></td><td>71</td><td>70</td><td>69</td><td>68</td><td></td><td>66</td><td>65</td><td>64</td><td>63</td><td>61</td><td>59</td><td>58</td><td>57</td><td>56</td><td></td><td></td><td></td></tr> <tr><td>52</td><td></td><td>50</td><td>49</td><td></td><td>47</td><td></td><td></td><td></td><td></td><td>41</td><td></td><td></td><td>38</td><td>37</td><td>36</td><td>35</td><td>34</td><td>33</td></tr> <tr><td></td><td></td><td>73</td><td></td><td>32</td><td>31</td><td>30</td><td>29</td><td>28</td><td>27</td><td></td><td>24</td><td>23</td><td></td><td></td><td>20</td><td>19</td><td>18</td><td>17</td></tr> <tr><td></td><td></td><td></td><td>16</td><td>15</td><td>14</td><td>13</td><td>12</td><td>11</td><td>10</td><td>9</td><td></td><td></td><td></td><td></td><td></td><td></td><td></td><td>1</td></tr> </table>		71	70	69	68		66	65	64	63	61	59	58	57	56				52		50	49		47					41			38	37	36	35	34	33			73		32	31	30	29	28	27		24	23			20	19	18	17				16	15	14	13	12	11	10	9								1
	71	70	69	68		66	65	64	63	61	59	58	57	56																																																																				
52		50	49		47					41			38	37	36	35	34	33																																																																
		73		32	31	30	29	28	27		24	23			20	19	18	17																																																																
			16	15	14	13	12	11	10	9								1																																																																
AVAILABLE	NOT APPLICABLE	34566-9703	G	0	A	BLACK	<table border="1"> <tr><td>72</td><td>71</td><td>70</td><td>69</td><td>68</td><td></td><td></td><td>65</td><td>64</td><td>63</td><td>61</td><td>59</td><td></td><td>57</td><td>56</td><td></td><td></td><td></td></tr> <tr><td>52</td><td>51</td><td>50</td><td>49</td><td></td><td>47</td><td></td><td></td><td></td><td></td><td>41</td><td></td><td></td><td>38</td><td>37</td><td>36</td><td></td><td>34</td><td>33</td></tr> <tr><td></td><td></td><td>73</td><td></td><td>32</td><td>31</td><td>30</td><td>29</td><td>28</td><td>27</td><td></td><td>24</td><td>23</td><td></td><td></td><td>20</td><td>19</td><td>18</td><td>17</td></tr> <tr><td></td><td></td><td></td><td>16</td><td></td><td></td><td>13</td><td>12</td><td>11</td><td>10</td><td>9</td><td></td><td></td><td></td><td></td><td>3</td><td>2</td><td></td><td>1</td></tr> </table>	72	71	70	69	68			65	64	63	61	59		57	56				52	51	50	49		47					41			38	37	36		34	33			73		32	31	30	29	28	27		24	23			20	19	18	17				16			13	12	11	10	9					3	2		1
72	71	70	69	68			65	64	63	61	59		57	56																																																																				
52	51	50	49		47					41			38	37	36		34	33																																																																
		73		32	31	30	29	28	27		24	23			20	19	18	17																																																																
			16			13	12	11	10	9					3	2		1																																																																
AVAILABLE	NOT APPLICABLE	34566-9803	G	0	A	BLACK	<table border="1"> <tr><td>72</td><td>71</td><td>70</td><td>69</td><td>68</td><td></td><td></td><td>65</td><td>64</td><td>63</td><td>61</td><td>59</td><td></td><td>57</td><td>56</td><td></td><td></td><td></td></tr> <tr><td>52</td><td>51</td><td>50</td><td>49</td><td></td><td>47</td><td></td><td></td><td></td><td></td><td>41</td><td></td><td></td><td>38</td><td>37</td><td>36</td><td></td><td>34</td><td>33</td></tr> <tr><td></td><td></td><td>73</td><td></td><td>32</td><td>31</td><td>30</td><td>29</td><td>28</td><td>27</td><td></td><td>24</td><td>23</td><td></td><td></td><td>20</td><td>19</td><td>18</td><td>17</td></tr> <tr><td></td><td></td><td></td><td>16</td><td></td><td></td><td>13</td><td>12</td><td>11</td><td>10</td><td>9</td><td></td><td></td><td></td><td></td><td></td><td></td><td></td><td>1</td></tr> </table>	72	71	70	69	68			65	64	63	61	59		57	56				52	51	50	49		47					41			38	37	36		34	33			73		32	31	30	29	28	27		24	23			20	19	18	17				16			13	12	11	10	9								1
72	71	70	69	68			65	64	63	61	59		57	56																																																																				
52	51	50	49		47					41			38	37	36		34	33																																																																
		73		32	31	30	29	28	27		24	23			20	19	18	17																																																																
			16			13	12	11	10	9								1																																																																
AVAILABLE	NOT APPLICABLE	34566-9903	G	0	A	BLACK	<table border="1"> <tr><td></td><td>71</td><td></td><td>69</td><td>68</td><td></td><td></td><td>65</td><td>64</td><td>63</td><td>61</td><td>59</td><td>58</td><td>57</td><td>56</td><td></td><td></td><td></td></tr> <tr><td>52</td><td></td><td>50</td><td>49</td><td></td><td>47</td><td></td><td></td><td></td><td></td><td>41</td><td></td><td></td><td>38</td><td>37</td><td>36</td><td></td><td>34</td><td>33</td></tr> <tr><td></td><td></td><td>73</td><td></td><td>32</td><td>31</td><td>30</td><td>29</td><td>28</td><td>27</td><td></td><td>24</td><td>23</td><td></td><td></td><td>20</td><td>19</td><td>18</td><td>17</td></tr> <tr><td></td><td></td><td></td><td>16</td><td></td><td></td><td>13</td><td>12</td><td>11</td><td>10</td><td>9</td><td></td><td></td><td></td><td></td><td></td><td></td><td></td><td>1</td></tr> </table>		71		69	68			65	64	63	61	59	58	57	56				52		50	49		47					41			38	37	36		34	33			73		32	31	30	29	28	27		24	23			20	19	18	17				16			13	12	11	10	9								1
	71		69	68			65	64	63	61	59	58	57	56																																																																				
52		50	49		47					41			38	37	36		34	33																																																																
		73		32	31	30	29	28	27		24	23			20	19	18	17																																																																
			16			13	12	11	10	9								1																																																																

SEE NEXT PAGE FOR ADDITIONAL NUMBERS

ENTER DESCRIPTION EC NO: UAU2013-0662 DRAWN BY CHKD APPR: IKOSHY 2012/11/21 REV 06	QUALITY SYMBOLS	GENERAL TOLERANCES (UNLESS SPECIFIED)	DIMENSION STYLE	SCALE	DESIGN UNITS	THIRD ANGLE PROJECTION	
	∇=0 ∇=0 ∇=0	4 PLACES ±--- INCH 3 PLACES ±--- INCH 2 PLACES ±--- INCH 1 PLACE ±--- INCH 0 PLACE ±--- INCH	mm INCH ±--- ±--- ±--- ±--- ±--- ±--- ±--- ±--- ±--- ±---	MM ONLY DRAWN BY SKRA JENDRANA DATE 2011/02/14 CHECKED BY DATE MVANSLAMBROU DATE 2011/02/14 APPROVED BY		METRIC	MX123 66/73/80CKT HRNS CONN ASSY molex
	ANGULAR ±---° DRAFT WHERE APPLICABLE MUST REMAIN WITHIN DIMENSIONS	MATERIAL NO. SEE BOM TABLE	DOCUMENT NO. SD-34566-001	SHEET NO. 14 OF 59			
	THIS DRAWING CONTAINS INFORMATION THAT IS PROPRIETARY TO MOLEX INCORPORATED AND SHOULD NOT BE USED WITHOUT WRITTEN PERMISSION						

STATUS	GM PART #	MATERIAL #	PART/MATERIAL REVISION	WIRE DRESS OPTION	KEY OPTION	COLOR (TPA)	NUMBERS INDICATE CAVITIES OPEN FOR CIRCUITS																																																																										
AVAILABLE	NOT APPLICABLE	34566-1013	G	0	A	BLACK	<table border="1"> <tr><td>71</td><td>69</td><td>68</td><td></td><td>65</td><td>64</td><td>63</td><td>61</td><td>59</td><td>58</td><td>57</td><td>56</td><td></td><td></td><td></td></tr> <tr><td>52</td><td>50</td><td>49</td><td>47</td><td></td><td></td><td></td><td>41</td><td></td><td></td><td>38</td><td>37</td><td>36</td><td>34</td><td>33</td></tr> <tr><td></td><td></td><td>73</td><td>32</td><td>31</td><td>30</td><td>29</td><td>28</td><td>27</td><td></td><td>24</td><td>23</td><td></td><td>20</td><td>19</td><td>18</td><td>17</td></tr> <tr><td></td><td></td><td></td><td>16</td><td></td><td></td><td>13</td><td>12</td><td>11</td><td>10</td><td>9</td><td></td><td></td><td></td><td>3</td><td>2</td><td>1</td></tr> </table>	71	69	68		65	64	63	61	59	58	57	56				52	50	49	47				41			38	37	36	34	33			73	32	31	30	29	28	27		24	23		20	19	18	17				16			13	12	11	10	9				3	2	1										
71	69	68		65	64	63	61	59	58	57	56																																																																						
52	50	49	47				41			38	37	36	34	33																																																																			
		73	32	31	30	29	28	27		24	23		20	19	18	17																																																																	
			16			13	12	11	10	9				3	2	1																																																																	
AVAILABLE	NOT APPLICABLE	34566-1023	G	0	A	BLACK	<table border="1"> <tr><td></td><td>70</td><td></td><td>67</td><td>66</td><td>65</td><td></td><td></td><td></td><td></td><td>58</td><td>57</td><td>55</td><td>54</td><td></td></tr> <tr><td></td><td>50</td><td>49</td><td>47</td><td></td><td></td><td>44</td><td>43</td><td>42</td><td>41</td><td></td><td>39</td><td>37</td><td>35</td><td></td></tr> <tr><td></td><td></td><td>73</td><td>32</td><td>30</td><td></td><td>27</td><td>26</td><td>25</td><td>24</td><td></td><td>21</td><td>20</td><td>19</td><td>18</td><td>17</td></tr> <tr><td></td><td></td><td></td><td>16</td><td>15</td><td>13</td><td></td><td>10</td><td>9</td><td>8</td><td>6</td><td>5</td><td></td><td>3</td><td>2</td><td>1</td></tr> </table>		70		67	66	65					58	57	55	54			50	49	47			44	43	42	41		39	37	35				73	32	30		27	26	25	24		21	20	19	18	17				16	15	13		10	9	8	6	5		3	2	1												
	70		67	66	65					58	57	55	54																																																																				
	50	49	47			44	43	42	41		39	37	35																																																																				
		73	32	30		27	26	25	24		21	20	19	18	17																																																																		
			16	15	13		10	9	8	6	5		3	2	1																																																																		
AVAILABLE	NOT APPLICABLE	34566-1033	G	0	A	BLACK	<table border="1"> <tr><td>72</td><td>70</td><td></td><td>67</td><td>66</td><td>65</td><td></td><td></td><td></td><td></td><td>58</td><td>57</td><td>55</td><td>54</td><td></td></tr> <tr><td></td><td>50</td><td>49</td><td>47</td><td></td><td></td><td>44</td><td>43</td><td>42</td><td>41</td><td></td><td>39</td><td>37</td><td>35</td><td></td></tr> <tr><td></td><td></td><td>73</td><td>32</td><td>30</td><td></td><td>27</td><td>26</td><td>25</td><td>24</td><td></td><td>21</td><td>20</td><td>19</td><td>18</td><td>17</td></tr> <tr><td></td><td></td><td></td><td>16</td><td>15</td><td>13</td><td></td><td>10</td><td>9</td><td>8</td><td>6</td><td>5</td><td></td><td>3</td><td>2</td><td>1</td></tr> </table>	72	70		67	66	65					58	57	55	54			50	49	47			44	43	42	41		39	37	35				73	32	30		27	26	25	24		21	20	19	18	17				16	15	13		10	9	8	6	5		3	2	1												
72	70		67	66	65					58	57	55	54																																																																				
	50	49	47			44	43	42	41		39	37	35																																																																				
		73	32	30		27	26	25	24		21	20	19	18	17																																																																		
			16	15	13		10	9	8	6	5		3	2	1																																																																		
AVAILABLE	NOT APPLICABLE	34566-1043	G	0	B	ST GRY	<table border="1"> <tr><td>71</td><td>70</td><td>68</td><td></td><td>66</td><td>65</td><td></td><td></td><td></td><td></td><td>59</td><td>58</td><td>57</td><td></td><td>54</td><td>53</td></tr> <tr><td>51</td><td>50</td><td>49</td><td>48</td><td>46</td><td>45</td><td></td><td>43</td><td>41</td><td>40</td><td>39</td><td>38</td><td>37</td><td>36</td><td>35</td><td>33</td></tr> <tr><td></td><td></td><td>73</td><td>32</td><td>31</td><td>30</td><td></td><td></td><td></td><td></td><td>24</td><td>23</td><td>22</td><td></td><td>20</td><td></td></tr> <tr><td></td><td></td><td></td><td>16</td><td></td><td></td><td>13</td><td>12</td><td>11</td><td>10</td><td>9</td><td>8</td><td>7</td><td>6</td><td>5</td><td>4</td></tr> </table>	71	70	68		66	65					59	58	57		54	53	51	50	49	48	46	45		43	41	40	39	38	37	36	35	33			73	32	31	30					24	23	22		20					16			13	12	11	10	9	8	7	6	5	4										
71	70	68		66	65					59	58	57		54	53																																																																		
51	50	49	48	46	45		43	41	40	39	38	37	36	35	33																																																																		
		73	32	31	30					24	23	22		20																																																																			
			16			13	12	11	10	9	8	7	6	5	4																																																																		
AVAILABLE	NOT APPLICABLE	34566-1053	G	0	H	ST GRY	<table border="1"> <tr><td>79</td><td>78</td><td>77</td><td>76</td><td>75</td><td>74</td><td>73</td><td>72</td><td>71</td><td>70</td><td>69</td><td>68</td><td></td><td>66</td><td>65</td><td>64</td><td>63</td><td>61</td></tr> <tr><td>60</td><td>59</td><td>58</td><td>57</td><td>56</td><td></td><td></td><td>53</td><td>52</td><td>50</td><td></td><td></td><td></td><td></td><td></td><td>44</td><td>43</td><td>41</td></tr> <tr><td>40</td><td>39</td><td>38</td><td>37</td><td></td><td>35</td><td>34</td><td>33</td><td>32</td><td></td><td>30</td><td>29</td><td></td><td>27</td><td>26</td><td></td><td></td><td>22</td><td>21</td></tr> <tr><td>20</td><td>19</td><td>18</td><td>17</td><td>16</td><td></td><td>14</td><td>13</td><td>12</td><td>11</td><td></td><td>9</td><td>8</td><td>6</td><td>5</td><td></td><td>3</td><td>2</td><td></td></tr> </table>	79	78	77	76	75	74	73	72	71	70	69	68		66	65	64	63	61	60	59	58	57	56			53	52	50						44	43	41	40	39	38	37		35	34	33	32		30	29		27	26			22	21	20	19	18	17	16		14	13	12	11		9	8	6	5		3	2	
79	78	77	76	75	74	73	72	71	70	69	68		66	65	64	63	61																																																																
60	59	58	57	56			53	52	50						44	43	41																																																																
40	39	38	37		35	34	33	32		30	29		27	26			22	21																																																															
20	19	18	17	16		14	13	12	11		9	8	6	5		3	2																																																																
AVAILABLE	NOT APPLICABLE	34566-1063	G	0	B	ST GRY	<table border="1"> <tr><td></td><td></td><td></td><td></td><td></td><td>65</td><td></td><td></td><td></td><td></td><td>60</td><td>59</td><td>57</td><td>56</td><td>55</td><td>53</td><td></td></tr> <tr><td></td><td></td><td>49</td><td>48</td><td>47</td><td></td><td>44</td><td></td><td></td><td></td><td>40</td><td>39</td><td>37</td><td>36</td><td>35</td><td>33</td><td></td></tr> <tr><td></td><td></td><td></td><td></td><td></td><td></td><td>29</td><td>28</td><td></td><td></td><td>24</td><td>23</td><td>21</td><td></td><td></td><td></td><td></td><td></td><td></td></tr> <tr><td></td><td></td><td></td><td></td><td></td><td></td><td></td><td></td><td></td><td></td><td></td><td></td><td></td><td></td><td></td><td></td><td></td><td></td><td>2</td></tr> </table>						65					60	59	57	56	55	53				49	48	47		44				40	39	37	36	35	33								29	28			24	23	21																									2		
					65					60	59	57	56	55	53																																																																		
		49	48	47		44				40	39	37	36	35	33																																																																		
						29	28			24	23	21																																																																					
																		2																																																															
AVAILABLE	NOT APPLICABLE	34566-1073	G	0	A	BLACK	<table border="1"> <tr><td>72</td><td>71</td><td>70</td><td>69</td><td>68</td><td>67</td><td>66</td><td>65</td><td>64</td><td>63</td><td>61</td><td>59</td><td>58</td><td>57</td><td>56</td><td>54</td><td></td></tr> <tr><td></td><td>50</td><td>49</td><td>48</td><td>47</td><td></td><td></td><td></td><td></td><td></td><td>42</td><td>41</td><td></td><td>38</td><td>37</td><td>36</td><td>34</td><td>33</td></tr> <tr><td></td><td></td><td>73</td><td>32</td><td>31</td><td>30</td><td>29</td><td>28</td><td>27</td><td>26</td><td></td><td>24</td><td>23</td><td></td><td>20</td><td>19</td><td>18</td><td></td></tr> <tr><td></td><td></td><td></td><td>16</td><td></td><td></td><td>13</td><td>12</td><td>11</td><td>10</td><td>9</td><td></td><td></td><td></td><td></td><td></td><td></td><td></td></tr> </table>	72	71	70	69	68	67	66	65	64	63	61	59	58	57	56	54			50	49	48	47						42	41		38	37	36	34	33			73	32	31	30	29	28	27	26		24	23		20	19	18					16			13	12	11	10	9										
72	71	70	69	68	67	66	65	64	63	61	59	58	57	56	54																																																																		
	50	49	48	47						42	41		38	37	36	34	33																																																																
		73	32	31	30	29	28	27	26		24	23		20	19	18																																																																	
			16			13	12	11	10	9																																																																							
AVAILABLE	NOT APPLICABLE	34566-1083	G	0	B	ST GRY	<table border="1"> <tr><td></td><td></td><td></td><td>68</td><td>67</td><td>66</td><td>65</td><td>64</td><td></td><td></td><td></td><td>59</td><td>58</td><td>57</td><td>55</td><td>54</td><td>53</td></tr> <tr><td></td><td>51</td><td>50</td><td>49</td><td>48</td><td>46</td><td>45</td><td></td><td>43</td><td>42</td><td>41</td><td>40</td><td>39</td><td>38</td><td>37</td><td>35</td><td>33</td></tr> <tr><td></td><td></td><td></td><td>73</td><td>32</td><td>31</td><td>30</td><td></td><td></td><td>26</td><td>24</td><td>23</td><td>22</td><td></td><td>20</td><td></td><td></td><td></td></tr> <tr><td></td><td></td><td></td><td></td><td>16</td><td></td><td></td><td>13</td><td></td><td>10</td><td>9</td><td>8</td><td>7</td><td>6</td><td>5</td><td>4</td><td>3</td><td>2</td><td></td></tr> </table>				68	67	66	65	64				59	58	57	55	54	53		51	50	49	48	46	45		43	42	41	40	39	38	37	35	33				73	32	31	30			26	24	23	22		20								16			13		10	9	8	7	6	5	4	3	2				
			68	67	66	65	64				59	58	57	55	54	53																																																																	
	51	50	49	48	46	45		43	42	41	40	39	38	37	35	33																																																																	
			73	32	31	30			26	24	23	22		20																																																																			
				16			13		10	9	8	7	6	5	4	3	2																																																																

SEE NEXT PAGE FOR ADDITIONAL NUMBERS

ENTER DESCRIPTION EC NO: UAU2013-0662 DRAWN BY: DRWINNYE CHKD: APPR: WOSHY F86 2012/11/21 2012/11/21 DESCRIPTION REV	QUALITY SYMBOLS	GENERAL TOLERANCES (UNLESS SPECIFIED)	DIMENSION STYLE	SCALE	DESIGN UNITS	THIRD ANGLE PROJECTION	
	∇=0 ∇=0 ∇=0 ∇=0	4 PLACES ± --- 3 PLACES ± --- 2 PLACES ± --- 1 PLACE ± --- 0 PLACE ± ---	mm INCH ± --- ± --- ± --- ± --- ± --- ± --- ± --- ± ---	MM ONLY DRAWN BY: SKRA JENDRANA 2011/02/14 CHECKED BY: MVANSLAMBROU 2011/02/14 APPROVED BY:	DATE: 2011/02/14 DATE: 2011/02/14 DATE:	METRIC MX123 66/73/80CKT HRNS CONN ASSY molex	□
	ANGULAR ± ---° DRAFT WHERE APPLICABLE MUST REMAIN WITHIN DIMENSIONS	SEE BOM TABLE MATERIAL NO. SIZE D	DOCUMENT NO. SD-34566-001	SHEET NO. 15 OF 59			
	THIS DRAWING CONTAINS INFORMATION THAT IS PROPRIETARY TO MOLEX INCORPORATED AND SHOULD NOT BE USED WITHOUT WRITTEN PERMISSION						

STATUS	GM PART #	MATERIAL #	PART/MATERIAL REVISION	WIRE DRESS OPTION	KEY OPTION	COLOR (TPA)	NUMBERS INDICATE CAVITIES OPEN FOR CIRCUITS																																																																									
AVAILABLE	NOT APPLICABLE	34566-1093	G	0	A	BLACK	<table border="1"> <tr><td></td><td>70</td><td>68</td><td>67</td><td>66</td><td></td><td></td><td></td><td></td><td></td><td></td><td></td><td></td><td></td><td>58</td><td>56</td><td>55</td><td>54</td></tr> <tr><td></td><td></td><td>49</td><td>47</td><td></td><td>44</td><td>43</td><td>42</td><td>41</td><td>39</td><td>37</td><td>36</td><td>34</td><td></td><td></td><td></td><td></td><td></td></tr> <tr><td></td><td>73</td><td></td><td>31</td><td>30</td><td></td><td>27</td><td>25</td><td>24</td><td></td><td>21</td><td>20</td><td>19</td><td>18</td><td></td><td></td><td></td><td></td></tr> <tr><td></td><td></td><td></td><td></td><td></td><td>13</td><td></td><td></td><td></td><td>6</td><td>5</td><td>4</td><td>3</td><td>1</td><td></td><td></td><td></td><td></td></tr> </table>		70	68	67	66										58	56	55	54			49	47		44	43	42	41	39	37	36	34							73		31	30		27	25	24		21	20	19	18										13				6	5	4	3	1					
	70	68	67	66										58	56	55	54																																																															
		49	47		44	43	42	41	39	37	36	34																																																																				
	73		31	30		27	25	24		21	20	19	18																																																																			
					13				6	5	4	3	1																																																																			
AVAILABLE	NOT APPLICABLE	34566-1123	G	0	H	ST GRAY	<table border="1"> <tr><td></td><td>78</td><td></td><td></td><td></td><td></td><td>72</td><td>71</td><td>70</td><td>69</td><td>68</td><td>67</td><td>66</td><td>65</td><td>64</td><td>63</td><td>61</td></tr> <tr><td></td><td>58</td><td>57</td><td>56</td><td></td><td>53</td><td>52</td><td>51</td><td>50</td><td></td><td></td><td></td><td></td><td></td><td></td><td>44</td><td>43</td><td>41</td></tr> <tr><td>40</td><td></td><td>37</td><td>35</td><td>34</td><td>33</td><td>32</td><td>30</td><td>29</td><td></td><td>27</td><td>26</td><td></td><td></td><td></td><td></td><td></td><td>22</td><td>21</td></tr> <tr><td>20</td><td>19</td><td>18</td><td>17</td><td>16</td><td></td><td>14</td><td></td><td>12</td><td>10</td><td>9</td><td>8</td><td>7</td><td>6</td><td>5</td><td></td><td>3</td><td>2</td><td>1</td></tr> </table>		78					72	71	70	69	68	67	66	65	64	63	61		58	57	56		53	52	51	50							44	43	41	40		37	35	34	33	32	30	29		27	26						22	21	20	19	18	17	16		14		12	10	9	8	7	6	5		3	2	1
	78					72	71	70	69	68	67	66	65	64	63	61																																																																
	58	57	56		53	52	51	50							44	43	41																																																															
40		37	35	34	33	32	30	29		27	26						22	21																																																														
20	19	18	17	16		14		12	10	9	8	7	6	5		3	2	1																																																														
AVAILABLE	NOT APPLICABLE	34566-1133	G	0	A	BLACK	<table border="1"> <tr><td></td><td>70</td><td>68</td><td>67</td><td>66</td><td></td><td></td><td></td><td></td><td></td><td>61</td><td></td><td></td><td></td><td>58</td><td>57</td><td>55</td><td>54</td></tr> <tr><td></td><td></td><td>49</td><td>47</td><td></td><td>45</td><td>44</td><td>43</td><td>42</td><td>41</td><td>39</td><td>37</td><td>34</td><td></td><td></td><td></td><td></td><td></td></tr> <tr><td></td><td>73</td><td></td><td>32</td><td>30</td><td></td><td>27</td><td>25</td><td>24</td><td></td><td></td><td></td><td>21</td><td>20</td><td>19</td><td>18</td><td></td><td></td></tr> <tr><td></td><td></td><td></td><td></td><td></td><td>13</td><td></td><td>11</td><td></td><td></td><td></td><td></td><td>6</td><td>5</td><td></td><td>3</td><td></td><td>1</td></tr> </table>		70	68	67	66						61				58	57	55	54			49	47		45	44	43	42	41	39	37	34							73		32	30		27	25	24				21	20	19	18								13		11					6	5		3		1	
	70	68	67	66						61				58	57	55	54																																																															
		49	47		45	44	43	42	41	39	37	34																																																																				
	73		32	30		27	25	24				21	20	19	18																																																																	
					13		11					6	5		3		1																																																															
AVAILABLE	NOT APPLICABLE	34566-1143	G	0	A	BLACK	<table border="1"> <tr><td></td><td></td><td>68</td><td></td><td>65</td><td></td><td>63</td><td></td><td>61</td><td></td><td>59</td><td>58</td><td></td><td>56</td><td></td><td></td><td></td><td>53</td></tr> <tr><td>52</td><td>50</td><td></td><td>47</td><td></td><td></td><td></td><td></td><td>41</td><td></td><td></td><td>38</td><td>37</td><td>36</td><td>35</td><td>34</td><td>33</td><td></td></tr> <tr><td></td><td>73</td><td></td><td>32</td><td>31</td><td>30</td><td>29</td><td>28</td><td>27</td><td>25</td><td>24</td><td>23</td><td>22</td><td>21</td><td>20</td><td>19</td><td>18</td><td>17</td></tr> <tr><td></td><td></td><td></td><td>16</td><td>15</td><td>14</td><td>13</td><td>12</td><td>11</td><td>10</td><td>9</td><td></td><td></td><td></td><td></td><td></td><td></td><td>1</td></tr> </table>			68		65		63		61		59	58		56				53	52	50		47					41			38	37	36	35	34	33			73		32	31	30	29	28	27	25	24	23	22	21	20	19	18	17				16	15	14	13	12	11	10	9							1	
		68		65		63		61		59	58		56				53																																																															
52	50		47					41			38	37	36	35	34	33																																																																
	73		32	31	30	29	28	27	25	24	23	22	21	20	19	18	17																																																															
			16	15	14	13	12	11	10	9							1																																																															
AVAILABLE	NOT APPLICABLE	34566-1153	G	0	A	BLACK	<table border="1"> <tr><td></td><td>70</td><td></td><td>67</td><td>66</td><td>65</td><td></td><td></td><td></td><td></td><td></td><td></td><td></td><td></td><td>58</td><td>57</td><td>55</td><td></td></tr> <tr><td></td><td></td><td>49</td><td>47</td><td></td><td></td><td>44</td><td>43</td><td>42</td><td>41</td><td>39</td><td>37</td><td></td><td></td><td></td><td></td><td></td><td></td></tr> <tr><td></td><td>73</td><td></td><td>32</td><td>30</td><td></td><td>27</td><td>25</td><td>24</td><td>23</td><td></td><td>21</td><td>20</td><td>19</td><td>18</td><td></td><td></td><td></td></tr> <tr><td></td><td></td><td></td><td></td><td></td><td>13</td><td></td><td></td><td></td><td></td><td>8</td><td>6</td><td>5</td><td></td><td>3</td><td></td><td></td><td>1</td></tr> </table>		70		67	66	65									58	57	55				49	47			44	43	42	41	39	37								73		32	30		27	25	24	23		21	20	19	18									13					8	6	5		3			1	
	70		67	66	65									58	57	55																																																																
		49	47			44	43	42	41	39	37																																																																					
	73		32	30		27	25	24	23		21	20	19	18																																																																		
					13					8	6	5		3			1																																																															
AVAILABLE	NOT APPLICABLE	34566-1163	G	0	H	ST GRAY	<table border="1"> <tr><td></td><td>78</td><td></td><td></td><td></td><td></td><td>72</td><td>71</td><td>70</td><td>69</td><td>68</td><td></td><td>66</td><td>65</td><td>64</td><td>63</td><td>61</td></tr> <tr><td>60</td><td>59</td><td>58</td><td>57</td><td>56</td><td></td><td>53</td><td>52</td><td>50</td><td></td><td></td><td></td><td></td><td></td><td></td><td>44</td><td>43</td><td>41</td></tr> <tr><td>40</td><td></td><td>37</td><td>35</td><td>34</td><td></td><td>32</td><td>30</td><td>29</td><td></td><td>27</td><td>26</td><td></td><td></td><td></td><td></td><td></td><td>22</td><td>21</td></tr> <tr><td>20</td><td>19</td><td>18</td><td>17</td><td>16</td><td></td><td>13</td><td>12</td><td></td><td></td><td>8</td><td>6</td><td>5</td><td></td><td>3</td><td>2</td><td></td><td></td><td></td></tr> </table>		78					72	71	70	69	68		66	65	64	63	61	60	59	58	57	56		53	52	50							44	43	41	40		37	35	34		32	30	29		27	26						22	21	20	19	18	17	16		13	12			8	6	5		3	2			
	78					72	71	70	69	68		66	65	64	63	61																																																																
60	59	58	57	56		53	52	50							44	43	41																																																															
40		37	35	34		32	30	29		27	26						22	21																																																														
20	19	18	17	16		13	12			8	6	5		3	2																																																																	
AVAILABLE	NOT APPLICABLE	34566-1173	G	0	A	BLACK	<table border="1"> <tr><td>72</td><td>71</td><td></td><td>69</td><td>68</td><td></td><td>65</td><td>64</td><td>63</td><td>62</td><td>61</td><td>60</td><td>59</td><td>58</td><td></td><td>56</td><td>54</td></tr> <tr><td>52</td><td>50</td><td>49</td><td>48</td><td>47</td><td></td><td>45</td><td></td><td></td><td>42</td><td>41</td><td></td><td></td><td>38</td><td>37</td><td>36</td><td>34</td><td>33</td></tr> <tr><td></td><td>73</td><td></td><td>32</td><td>31</td><td>30</td><td>29</td><td>28</td><td>27</td><td>26</td><td></td><td>24</td><td>23</td><td></td><td>20</td><td>19</td><td>18</td><td>17</td></tr> <tr><td></td><td></td><td></td><td>16</td><td></td><td>13</td><td>12</td><td>11</td><td>10</td><td>9</td><td></td><td></td><td></td><td></td><td></td><td></td><td></td><td></td></tr> </table>	72	71		69	68		65	64	63	62	61	60	59	58		56	54	52	50	49	48	47		45			42	41			38	37	36	34	33		73		32	31	30	29	28	27	26		24	23		20	19	18	17				16		13	12	11	10	9										
72	71		69	68		65	64	63	62	61	60	59	58		56	54																																																																
52	50	49	48	47		45			42	41			38	37	36	34	33																																																															
	73		32	31	30	29	28	27	26		24	23		20	19	18	17																																																															
			16		13	12	11	10	9																																																																							
AVAILABLE	NOT APPLICABLE	34566-1183	G	0	B	ST GRAY	<table border="1"> <tr><td></td><td></td><td></td><td></td><td>66</td><td>65</td><td>64</td><td></td><td>62</td><td></td><td></td><td>59</td><td></td><td>57</td><td></td><td>55</td><td>53</td></tr> <tr><td></td><td></td><td>49</td><td>48</td><td>47</td><td></td><td></td><td></td><td>44</td><td>42</td><td></td><td></td><td>39</td><td>37</td><td></td><td>35</td><td>33</td></tr> <tr><td></td><td>73</td><td></td><td></td><td></td><td></td><td>29</td><td>28</td><td></td><td></td><td></td><td>23</td><td></td><td>21</td><td></td><td></td><td>17</td></tr> <tr><td></td><td></td><td></td><td></td><td></td><td></td><td>12</td><td></td><td></td><td>9</td><td>7</td><td></td><td></td><td></td><td></td><td></td><td></td></tr> </table>					66	65	64		62			59		57		55	53			49	48	47				44	42			39	37		35	33		73					29	28				23		21			17							12			9	7											
				66	65	64		62			59		57		55	53																																																																
		49	48	47				44	42			39	37		35	33																																																																
	73					29	28				23		21			17																																																																
						12			9	7																																																																						

ENTER DESCRIPTION EC NO: UAU2013-0662 DRAWN BY: CHKD: APPR: IKOSHY 2012/11/21 2012/11/21 2012/11/21 F06	QUALITY SYMBOLS	GENERAL TOLERANCES (UNLESS SPECIFIED)	DIMENSION STYLE	SCALE	DESIGN UNITS	THIRD ANGLE PROJECTION
	▽=0	4 PLACES ± mm ± INCH	MM ONLY	DRAWN BY DATE	METRIC	
	▽=0	3 PLACES ± mm ± INCH	SKRAJENDRANA 2011/02/14	CHECKED BY DATE		
	▽=0	2 PLACES ± mm ± INCH	MVANS LAMBROU 2011/02/14	APPROVED BY DATE		
	▽=0	1 PLACE ± mm ± INCH				
	ANGULAR ± °	DRAFT WHERE APPLICABLE MUST REMAIN WITHIN DIMENSIONS	MATERIAL NO.	DOCUMENT NO.		SHEET NO.
			SEE BOM TABLE	SD-34566-001		16 OF 59
THIS DRAWING CONTAINS INFORMATION THAT IS PROPRIETARY TO MOLEX INCORPORATED AND SHOULD NOT BE USED WITHOUT WRITTEN PERMISSION						

STATUS	GM PART #	MATERIAL #	PART/MATERIAL REVISION	WIRE DRESS OPTION	KEY OPTION	COLOR (TPA)	NUMBERS INDICATE CAVITIES OPEN FOR CIRCUITS																																																																						
AVAILABLE	NOT APPLICABLE	34566-1193	G	0	A	BLACK	<table border="1"> <tr><td>72</td><td>71</td><td>69</td><td>68</td><td>67</td><td>66</td><td>64</td><td>63</td><td>62</td><td>60</td><td>59</td><td></td><td></td><td></td><td>54</td><td>53</td></tr> <tr><td>52</td><td></td><td>49</td><td>48</td><td>46</td><td>44</td><td>43</td><td>42</td><td></td><td>39</td><td></td><td></td><td></td><td></td><td>34</td><td>33</td></tr> <tr><td></td><td></td><td></td><td>32</td><td></td><td>29</td><td>27</td><td></td><td></td><td>23</td><td></td><td></td><td></td><td></td><td>17</td><td></td></tr> <tr><td></td><td>73</td><td></td><td></td><td>14</td><td>13</td><td>12</td><td>11</td><td>9</td><td>8</td><td>7</td><td>6</td><td>5</td><td>4</td><td>3</td><td>2</td><td>1</td></tr> </table>	72	71	69	68	67	66	64	63	62	60	59				54	53	52		49	48	46	44	43	42		39					34	33				32		29	27			23					17			73			14	13	12	11	9	8	7	6	5	4	3	2	1					
72	71	69	68	67	66	64	63	62	60	59				54	53																																																														
52		49	48	46	44	43	42		39					34	33																																																														
			32		29	27			23					17																																																															
	73			14	13	12	11	9	8	7	6	5	4	3	2	1																																																													
AVAILABLE	NOT APPLICABLE	34566-1213	G	0	A	BLACK	<table border="1"> <tr><td>72</td><td>71</td><td>69</td><td>68</td><td>67</td><td>66</td><td>64</td><td>63</td><td>62</td><td></td><td>59</td><td></td><td></td><td></td><td>54</td><td>53</td></tr> <tr><td>52</td><td></td><td></td><td>48</td><td></td><td>46</td><td>44</td><td>43</td><td>42</td><td></td><td>39</td><td></td><td></td><td></td><td></td><td>33</td></tr> <tr><td></td><td></td><td></td><td></td><td>32</td><td></td><td>29</td><td>27</td><td></td><td></td><td>24</td><td>23</td><td></td><td></td><td></td><td>17</td></tr> <tr><td></td><td>73</td><td></td><td></td><td></td><td>14</td><td>13</td><td>12</td><td>11</td><td>9</td><td>8</td><td></td><td></td><td>5</td><td>4</td><td>3</td><td>2</td><td>1</td></tr> </table>	72	71	69	68	67	66	64	63	62		59				54	53	52			48		46	44	43	42		39					33					32		29	27			24	23				17		73				14	13	12	11	9	8			5	4	3	2	1				
72	71	69	68	67	66	64	63	62		59				54	53																																																														
52			48		46	44	43	42		39					33																																																														
				32		29	27			24	23				17																																																														
	73				14	13	12	11	9	8			5	4	3	2	1																																																												
AVAILABLE	NOT APPLICABLE	34566-1223	G	0	B	ST GRY	<table border="1"> <tr><td></td><td></td><td></td><td></td><td>67</td><td>66</td><td>65</td><td>63</td><td>62</td><td></td><td>59</td><td>57</td><td>55</td><td>53</td><td></td><td></td></tr> <tr><td></td><td></td><td></td><td>48</td><td></td><td></td><td></td><td>43</td><td>42</td><td></td><td>39</td><td>37</td><td>35</td><td>33</td><td></td><td></td></tr> <tr><td></td><td></td><td></td><td></td><td></td><td></td><td>29</td><td>27</td><td>26</td><td></td><td>23</td><td>21</td><td></td><td></td><td></td><td>17</td></tr> <tr><td></td><td>73</td><td></td><td></td><td></td><td></td><td></td><td>12</td><td></td><td>9</td><td>7</td><td></td><td></td><td></td><td></td><td></td><td></td><td></td></tr> </table>					67	66	65	63	62		59	57	55	53						48				43	42		39	37	35	33									29	27	26		23	21				17		73						12		9	7											
				67	66	65	63	62		59	57	55	53																																																																
			48				43	42		39	37	35	33																																																																
						29	27	26		23	21				17																																																														
	73						12		9	7																																																																			
AVAILABLE	NOT APPLICABLE	34566-1233	G	0	B	ST GRY	<table border="1"> <tr><td></td><td></td><td></td><td></td><td></td><td>65</td><td></td><td>62</td><td></td><td>59</td><td>57</td><td>55</td><td>53</td><td></td><td></td><td></td></tr> <tr><td></td><td></td><td></td><td>48</td><td>46</td><td></td><td></td><td>42</td><td></td><td>39</td><td>37</td><td>35</td><td>33</td><td></td><td></td><td></td></tr> <tr><td></td><td></td><td></td><td></td><td></td><td>29</td><td></td><td>26</td><td></td><td>23</td><td>21</td><td></td><td></td><td></td><td></td><td>17</td></tr> <tr><td></td><td>73</td><td></td><td></td><td></td><td></td><td>12</td><td></td><td>9</td><td>7</td><td></td><td></td><td></td><td></td><td></td><td></td><td></td><td></td></tr> </table>						65		62		59	57	55	53							48	46			42		39	37	35	33									29		26		23	21					17		73					12		9	7												
					65		62		59	57	55	53																																																																	
			48	46			42		39	37	35	33																																																																	
					29		26		23	21					17																																																														
	73					12		9	7																																																																				
AVAILABLE	NOT APPLICABLE	34566-1243	G	0	B	ST GRY	<table border="1"> <tr><td></td><td></td><td></td><td></td><td></td><td></td><td></td><td></td><td></td><td>59</td><td>57</td><td>55</td><td>53</td><td></td><td></td><td></td></tr> <tr><td></td><td>50</td><td>48</td><td>46</td><td></td><td></td><td></td><td></td><td></td><td>39</td><td>37</td><td>35</td><td>33</td><td></td><td></td><td></td></tr> <tr><td></td><td></td><td></td><td></td><td></td><td>29</td><td></td><td></td><td></td><td>23</td><td>21</td><td></td><td></td><td></td><td></td><td>17</td></tr> <tr><td></td><td>73</td><td></td><td></td><td>15</td><td></td><td>12</td><td></td><td></td><td>7</td><td>6</td><td>5</td><td>4</td><td>3</td><td></td><td></td><td></td><td></td></tr> </table>										59	57	55	53					50	48	46						39	37	35	33									29				23	21					17		73			15		12			7	6	5	4	3								
									59	57	55	53																																																																	
	50	48	46						39	37	35	33																																																																	
					29				23	21					17																																																														
	73			15		12			7	6	5	4	3																																																																
AVAILABLE	NOT APPLICABLE	34566-1253	G	9	B	ST GRY	<table border="1"> <tr><td></td><td></td><td>49</td><td>48</td><td>46</td><td>65</td><td></td><td></td><td></td><td>60</td><td>59</td><td>57</td><td>55</td><td>53</td><td></td><td></td></tr> <tr><td></td><td></td><td></td><td></td><td></td><td></td><td></td><td></td><td></td><td>40</td><td>39</td><td>37</td><td>35</td><td>33</td><td></td><td></td></tr> <tr><td></td><td></td><td></td><td></td><td></td><td></td><td></td><td></td><td></td><td>24</td><td>23</td><td>21</td><td></td><td></td><td></td><td>2</td><td></td><td></td></tr> <tr><td></td><td>73</td><td></td><td></td><td></td><td></td><td></td><td></td><td></td><td></td><td></td><td></td><td></td><td></td><td></td><td></td><td></td><td></td></tr> </table>			49	48	46	65				60	59	57	55	53												40	39	37	35	33												24	23	21				2				73																		
		49	48	46	65				60	59	57	55	53																																																																
									40	39	37	35	33																																																																
									24	23	21				2																																																														
	73																																																																												
AVAILABLE	NOT APPLICABLE	34566-1263	G	9	A	BLACK	<p>NUMBERS IN BOLD MUST USE SAE WIRE MEETING SAE J1128, WIRE SIZE (NO.20) OR (NO.18 MAX. O.D. OF 2.06 MM) PER G.M. DRAWING NUMBER 12582682.</p> <table border="1"> <tr><td>72</td><td>71</td><td>69</td><td>68</td><td>67</td><td>66</td><td>64</td><td>63</td><td>62</td><td></td><td>59</td><td></td><td>56</td><td></td><td>53</td><td></td></tr> <tr><td></td><td>50</td><td></td><td>48</td><td></td><td>46</td><td>44</td><td>43</td><td>42</td><td></td><td>39</td><td></td><td>36</td><td>35</td><td>33</td><td></td></tr> <tr><td></td><td></td><td></td><td></td><td>32</td><td>30</td><td>29</td><td>27</td><td></td><td></td><td>24</td><td>23</td><td></td><td>20</td><td>17</td><td></td></tr> <tr><td></td><td>73</td><td></td><td></td><td></td><td>14</td><td>13</td><td>12</td><td>11</td><td>9</td><td>8</td><td></td><td>5</td><td>4</td><td>3</td><td>2</td><td>1</td></tr> </table>	72	71	69	68	67	66	64	63	62		59		56		53			50		48		46	44	43	42		39		36	35	33						32	30	29	27			24	23		20	17			73				14	13	12	11	9	8		5	4	3	2	1					
72	71	69	68	67	66	64	63	62		59		56		53																																																															
	50		48		46	44	43	42		39		36	35	33																																																															
				32	30	29	27			24	23		20	17																																																															
	73				14	13	12	11	9	8		5	4	3	2	1																																																													
AVAILABLE	NOT APPLICABLE	34566-1273	G	0	A	BLACK	<table border="1"> <tr><td></td><td>70</td><td>69</td><td>68</td><td></td><td>65</td><td>64</td><td>63</td><td>61</td><td>59</td><td>58</td><td>57</td><td>56</td><td></td><td></td><td></td><td></td></tr> <tr><td>52</td><td>50</td><td>49</td><td>48</td><td>47</td><td></td><td></td><td></td><td>41</td><td></td><td>38</td><td>37</td><td>36</td><td>34</td><td>33</td><td></td><td></td></tr> <tr><td></td><td></td><td></td><td></td><td></td><td>32</td><td>31</td><td>30</td><td>29</td><td>28</td><td>27</td><td></td><td>24</td><td>23</td><td></td><td>20</td><td>19</td><td>18</td></tr> <tr><td></td><td>73</td><td></td><td></td><td>16</td><td></td><td></td><td>13</td><td>12</td><td>11</td><td>10</td><td>9</td><td></td><td></td><td></td><td></td><td></td><td>1</td></tr> </table>		70	69	68		65	64	63	61	59	58	57	56					52	50	49	48	47				41		38	37	36	34	33								32	31	30	29	28	27		24	23		20	19	18		73			16			13	12	11	10	9						1
	70	69	68		65	64	63	61	59	58	57	56																																																																	
52	50	49	48	47				41		38	37	36	34	33																																																															
					32	31	30	29	28	27		24	23		20	19	18																																																												
	73			16			13	12	11	10	9						1																																																												

ENTER DESCRIPTION ELEC NO: UAU2013-0662 DRAWN BY: 2012/11/01 CHKD: 2012/11/21 APPR: WOSHY REV: 186	QUALITY SYMBOLS	GENERAL TOLERANCES (UNLESS SPECIFIED)	DIMENSION STYLE	SCALE	DESIGN UNITS	THIRD ANGLE PROJECTION	
	∇=0 ∇=0 ∇=0	4 PLACES ± --- INCH 3 PLACES ± --- INCH 2 PLACES ± --- INCH 1 PLACE ± --- INCH 0 PLACE ± --- INCH	mm INCH mm INCH mm INCH mm INCH mm INCH	MM ONLY DRAWN BY: SKRAJENDRANA DATE: 2011/02/14 CHECKED BY: MVANSLAMBROU DATE: 2011/02/14 APPROVED BY:	METRIC	METRIC	MX123 66/73/80CKT HRNS CONN ASSY molex
	ANGULAR ± ---° DRAFT WHERE APPLICABLE MUST REMAIN WITHIN DIMENSIONS	SEE BOM TABLE MATERIAL NO. SD-34566-001 DOCUMENT NO.	SHEET NO. 17 OF 59				
	THIS DRAWING CONTAINS INFORMATION THAT IS PROPRIETARY TO MOLEX INCORPORATED AND SHOULD NOT BE USED WITHOUT WRITTEN PERMISSION						

STATUS	GM PART #	MATERIAL #	PART / MATERIAL REVISION	WIRE DRESS OPTION	KEY OPTION	COLOR (TPAL)	NUMBERS INDICATE CAVITIES OPEN FOR CIRCUITS																																																																															
AVAILABLE	NOT APPLICABLE	34566-1283	G	0	A	BLACK	<table border="1"> <tr><td>72</td><td>71</td><td>70</td><td>69</td><td>68</td><td>66</td><td>65</td><td>64</td><td>63</td><td>61</td><td>59</td><td>58</td><td>57</td><td>56</td><td>54</td></tr> <tr><td>52</td><td>50</td><td>49</td><td>48</td><td>47</td><td></td><td></td><td></td><td></td><td>42</td><td>41</td><td></td><td>38</td><td>37</td><td>36</td><td>34</td><td>33</td></tr> <tr><td></td><td></td><td></td><td>73</td><td>32</td><td>31</td><td>30</td><td>29</td><td>28</td><td>27</td><td>26</td><td>24</td><td>23</td><td></td><td>20</td><td>19</td><td>18</td></tr> <tr><td></td><td></td><td></td><td></td><td>16</td><td></td><td></td><td></td><td>13</td><td>12</td><td>11</td><td>10</td><td>9</td><td></td><td></td><td></td><td></td></tr> </table>	72	71	70	69	68	66	65	64	63	61	59	58	57	56	54	52	50	49	48	47					42	41		38	37	36	34	33				73	32	31	30	29	28	27	26	24	23		20	19	18					16				13	12	11	10	9																	
72	71	70	69	68	66	65	64	63	61	59	58	57	56	54																																																																								
52	50	49	48	47					42	41		38	37	36	34	33																																																																						
			73	32	31	30	29	28	27	26	24	23		20	19	18																																																																						
				16				13	12	11	10	9																																																																										
AVAILABLE	NOT APPLICABLE	34566-1293	G	0	A	BLACK	<table border="1"> <tr><td></td><td></td><td></td><td>68</td><td></td><td>65</td><td>63</td><td>61</td><td>59</td><td>58</td><td>56</td><td></td><td></td><td></td><td></td><td></td><td></td></tr> <tr><td>52</td><td>50</td><td></td><td>47</td><td></td><td></td><td></td><td>41</td><td></td><td>38</td><td>37</td><td>36</td><td></td><td></td><td>34</td><td>33</td><td></td></tr> <tr><td></td><td></td><td></td><td>73</td><td>32</td><td>31</td><td>30</td><td>29</td><td>28</td><td>27</td><td>26</td><td>24</td><td>23</td><td></td><td>20</td><td>19</td><td>18</td></tr> <tr><td></td><td></td><td></td><td></td><td>16</td><td></td><td></td><td></td><td>13</td><td>12</td><td>11</td><td>10</td><td>9</td><td></td><td></td><td></td><td>1</td></tr> </table>				68		65	63	61	59	58	56							52	50		47				41		38	37	36			34	33					73	32	31	30	29	28	27	26	24	23		20	19	18					16				13	12	11	10	9				1											
			68		65	63	61	59	58	56																																																																												
52	50		47				41		38	37	36			34	33																																																																							
			73	32	31	30	29	28	27	26	24	23		20	19	18																																																																						
				16				13	12	11	10	9				1																																																																						
AVAILABLE	NOT APPLICABLE	34566-1313	G	0	H	ST GRAY	<table border="1"> <tr><td>80</td><td>78</td><td></td><td></td><td></td><td></td><td></td><td>72</td><td>71</td><td>70</td><td>69</td><td>68</td><td>66</td><td>65</td><td>64</td><td>63</td><td>61</td></tr> <tr><td></td><td>58</td><td>57</td><td>56</td><td>55</td><td>54</td><td>53</td><td></td><td></td><td></td><td></td><td></td><td>46</td><td>44</td><td>43</td><td>42</td><td></td></tr> <tr><td>40</td><td></td><td>37</td><td>35</td><td></td><td></td><td></td><td>32</td><td>30</td><td>29</td><td></td><td>27</td><td>26</td><td></td><td></td><td></td><td>21</td></tr> <tr><td>20</td><td>19</td><td>18</td><td>17</td><td>15</td><td></td><td></td><td>12</td><td></td><td></td><td></td><td>8</td><td>6</td><td>5</td><td>3</td><td>2</td><td></td></tr> </table>	80	78						72	71	70	69	68	66	65	64	63	61		58	57	56	55	54	53						46	44	43	42		40		37	35				32	30	29		27	26				21	20	19	18	17	15			12				8	6	5	3	2												
80	78						72	71	70	69	68	66	65	64	63	61																																																																						
	58	57	56	55	54	53						46	44	43	42																																																																							
40		37	35				32	30	29		27	26				21																																																																						
20	19	18	17	15			12				8	6	5	3	2																																																																							
AVAILABLE	NOT APPLICABLE	34566-1323	G	0	A	BLACK	<table border="1"> <tr><td>72</td><td>71</td><td>70</td><td>69</td><td>68</td><td>67</td><td>66</td><td>65</td><td>64</td><td>63</td><td>62</td><td>60</td><td>59</td><td>58</td><td>57</td><td>56</td><td>55</td><td>54</td><td>53</td></tr> <tr><td>52</td><td>51</td><td>50</td><td>49</td><td>48</td><td>47</td><td>46</td><td>45</td><td>44</td><td>43</td><td>42</td><td>41</td><td>40</td><td>39</td><td>38</td><td>37</td><td>36</td><td>35</td><td>34</td><td>33</td></tr> <tr><td></td><td></td><td></td><td>73</td><td>32</td><td>31</td><td>30</td><td>29</td><td>28</td><td>27</td><td>26</td><td>25</td><td>24</td><td>23</td><td>22</td><td>21</td><td>20</td><td>19</td><td>18</td><td>17</td></tr> <tr><td></td><td></td><td></td><td></td><td>16</td><td>15</td><td>14</td><td>13</td><td>12</td><td>11</td><td>10</td><td>9</td><td>8</td><td>7</td><td>6</td><td>5</td><td>4</td><td>3</td><td>2</td><td>1</td></tr> </table>	72	71	70	69	68	67	66	65	64	63	62	60	59	58	57	56	55	54	53	52	51	50	49	48	47	46	45	44	43	42	41	40	39	38	37	36	35	34	33				73	32	31	30	29	28	27	26	25	24	23	22	21	20	19	18	17					16	15	14	13	12	11	10	9	8	7	6	5	4	3	2	1
72	71	70	69	68	67	66	65	64	63	62	60	59	58	57	56	55	54	53																																																																				
52	51	50	49	48	47	46	45	44	43	42	41	40	39	38	37	36	35	34	33																																																																			
			73	32	31	30	29	28	27	26	25	24	23	22	21	20	19	18	17																																																																			
				16	15	14	13	12	11	10	9	8	7	6	5	4	3	2	1																																																																			
AVAILABLE	NOT APPLICABLE	34566-1333	G	0	A	BLACK	<table border="1"> <tr><td></td><td></td><td>70</td><td>69</td><td>68</td><td></td><td></td><td>65</td><td>64</td><td></td><td></td><td>59</td><td>58</td><td>56</td><td></td><td></td><td></td><td></td><td></td></tr> <tr><td>52</td><td>50</td><td>49</td><td></td><td>47</td><td></td><td></td><td></td><td></td><td>41</td><td></td><td></td><td>38</td><td>37</td><td>36</td><td></td><td>34</td><td></td><td></td></tr> <tr><td></td><td></td><td></td><td>73</td><td>32</td><td>31</td><td>30</td><td>29</td><td>28</td><td>27</td><td></td><td>23</td><td></td><td></td><td>20</td><td>19</td><td>18</td><td>17</td><td></td></tr> <tr><td></td><td></td><td></td><td></td><td>16</td><td></td><td></td><td></td><td>13</td><td>12</td><td>11</td><td>10</td><td>9</td><td>8</td><td>6</td><td></td><td></td><td></td><td>1</td></tr> </table>			70	69	68			65	64			59	58	56						52	50	49		47					41			38	37	36		34						73	32	31	30	29	28	27		23			20	19	18	17						16				13	12	11	10	9	8	6				1			
		70	69	68			65	64			59	58	56																																																																									
52	50	49		47					41			38	37	36		34																																																																						
			73	32	31	30	29	28	27		23			20	19	18	17																																																																					
				16				13	12	11	10	9	8	6				1																																																																				
AVAILABLE	NOT APPLICABLE	34566-1343	G	0	A	BLACK	<table border="1"> <tr><td>72</td><td>71</td><td></td><td>69</td><td>67</td><td>65</td><td>64</td><td>63</td><td></td><td></td><td>59</td><td>58</td><td>57</td><td>56</td><td></td><td></td><td></td><td></td><td></td></tr> <tr><td></td><td>50</td><td>49</td><td>48</td><td>47</td><td></td><td></td><td></td><td>41</td><td></td><td></td><td>38</td><td>37</td><td>36</td><td></td><td>34</td><td></td><td></td><td></td></tr> <tr><td></td><td></td><td></td><td>73</td><td>32</td><td>31</td><td>30</td><td>29</td><td>28</td><td>27</td><td></td><td>23</td><td></td><td></td><td>20</td><td>19</td><td>18</td><td>17</td><td></td></tr> <tr><td></td><td></td><td></td><td></td><td>16</td><td></td><td></td><td></td><td>13</td><td>12</td><td>11</td><td>10</td><td>9</td><td>7</td><td>6</td><td>4</td><td>3</td><td>2</td><td>1</td></tr> </table>	72	71		69	67	65	64	63			59	58	57	56							50	49	48	47				41			38	37	36		34							73	32	31	30	29	28	27		23			20	19	18	17						16				13	12	11	10	9	7	6	4	3	2	1			
72	71		69	67	65	64	63			59	58	57	56																																																																									
	50	49	48	47				41			38	37	36		34																																																																							
			73	32	31	30	29	28	27		23			20	19	18	17																																																																					
				16				13	12	11	10	9	7	6	4	3	2	1																																																																				
AVAILABLE	NOT APPLICABLE	34566-1353	G	0	H	ST GRAY	<table border="1"> <tr><td></td><td>79</td><td>78</td><td>77</td><td>76</td><td>75</td><td>74</td><td>73</td><td>72</td><td>71</td><td>70</td><td>69</td><td>68</td><td>66</td><td>65</td><td>64</td><td>63</td><td>61</td></tr> <tr><td>60</td><td>59</td><td>58</td><td>57</td><td>56</td><td></td><td></td><td>53</td><td></td><td>50</td><td></td><td></td><td></td><td></td><td></td><td>44</td><td>43</td><td>41</td></tr> <tr><td>40</td><td>39</td><td>38</td><td>37</td><td></td><td>35</td><td>34</td><td></td><td>32</td><td>30</td><td>29</td><td></td><td>27</td><td>26</td><td></td><td></td><td></td><td>22</td><td>21</td></tr> <tr><td>20</td><td>19</td><td>18</td><td>17</td><td></td><td></td><td></td><td>13</td><td>12</td><td>11</td><td></td><td></td><td>8</td><td>6</td><td>5</td><td>3</td><td>2</td><td></td><td></td></tr> </table>		79	78	77	76	75	74	73	72	71	70	69	68	66	65	64	63	61	60	59	58	57	56			53		50						44	43	41	40	39	38	37		35	34		32	30	29		27	26				22	21	20	19	18	17				13	12	11			8	6	5	3	2							
	79	78	77	76	75	74	73	72	71	70	69	68	66	65	64	63	61																																																																					
60	59	58	57	56			53		50						44	43	41																																																																					
40	39	38	37		35	34		32	30	29		27	26				22	21																																																																				
20	19	18	17				13	12	11			8	6	5	3	2																																																																						
AVAILABLE	NOT APPLICABLE	34566-1363	G	0	A	BLACK	<table border="1"> <tr><td>72</td><td>71</td><td></td><td>69</td><td>68</td><td>67</td><td>66</td><td>64</td><td>63</td><td>62</td><td></td><td>59</td><td></td><td></td><td></td><td></td><td></td><td></td><td>53</td></tr> <tr><td></td><td></td><td></td><td>48</td><td>46</td><td>44</td><td>43</td><td>42</td><td></td><td></td><td></td><td>39</td><td></td><td></td><td></td><td></td><td></td><td></td><td>33</td></tr> <tr><td></td><td></td><td></td><td>73</td><td>32</td><td></td><td>29</td><td>27</td><td></td><td></td><td></td><td>24</td><td>23</td><td></td><td></td><td></td><td></td><td></td><td>17</td></tr> <tr><td></td><td></td><td></td><td></td><td></td><td>14</td><td>13</td><td>12</td><td>11</td><td></td><td>9</td><td>8</td><td></td><td></td><td>5</td><td>4</td><td>3</td><td>2</td><td>1</td></tr> </table>	72	71		69	68	67	66	64	63	62		59							53				48	46	44	43	42				39							33				73	32		29	27				24	23						17						14	13	12	11		9	8			5	4	3	2	1			
72	71		69	68	67	66	64	63	62		59							53																																																																				
			48	46	44	43	42				39							33																																																																				
			73	32		29	27				24	23						17																																																																				
					14	13	12	11		9	8			5	4	3	2	1																																																																				

ENTER DESCRIPTION ELEC NO: JAU2013-0662 DRAWN BY: CHKD CHKD: APPR: VKOSHY DATE: 2012/11/21 REV: 186	QUALITY SYMBOLS ∇=0 ∇=0 ∇=0	GENERAL TOLERANCES (UNLESS SPECIFIED) # mm # INCH 4 PLACES # --- # --- 3 PLACES # --- # --- 2 PLACES # --- # --- 1 PLACE # --- # --- 0 PLACE # --- # ---	DIMENSION STYLE MM ONLY	SCALE DESIGN UNITS METRIC	THIRD ANGLE PROJECTION
	DRAWN BY: SKRAJENDRANA 2011/02/14 CHECKED BY: DATE APPROVED BY: DATE		TITLE MX123 66/73/80CKT HRNS CONN ASSY		
	MATERIAL NO. SEE BOM TABLE		DOCUMENT NO. SD-34566-001		
	ANGULAR ± ---° DRAFT WHERE APPLICABLE MUST REMAIN WITHIN DIMENSIONS		SHEET NO. 18 OF 59		

STATUS	GM PART #	MATERIAL #	PART/MATERIAL REVISION	WIRE DRESS OPTION	KEY OPTION	COLOR (TPA)	NUMBERS INDICATE CAVITIES OPEN FOR CIRCUITS																																																																																															
AVAILABLE	NOT APPLICABLE	34566-1373	G	0	B	ST GR	<table border="1"> <tr><td></td><td></td><td></td><td></td><td></td><td></td><td></td><td></td><td></td><td></td><td>66</td><td>65</td><td></td><td></td><td>62</td><td></td><td>59</td><td>57</td><td>55</td><td>53</td></tr> <tr><td></td><td></td><td></td><td></td><td></td><td></td><td></td><td></td><td></td><td></td><td>48</td><td>46</td><td></td><td></td><td>42</td><td></td><td>39</td><td>37</td><td>35</td><td>33</td></tr> <tr><td></td><td></td><td></td><td></td><td></td><td></td><td></td><td>73</td><td></td><td></td><td></td><td></td><td>29</td><td></td><td>26</td><td></td><td>23</td><td>21</td><td></td><td>17</td></tr> <tr><td></td><td></td><td></td><td></td><td></td><td></td><td></td><td></td><td></td><td></td><td></td><td></td><td>12</td><td></td><td></td><td>9</td><td>7</td><td></td><td></td><td></td></tr> </table>											66	65			62		59	57	55	53											48	46			42		39	37	35	33								73					29		26		23	21		17													12			9	7																		
										66	65			62		59	57	55	53																																																																																			
										48	46			42		39	37	35	33																																																																																			
							73					29		26		23	21		17																																																																																			
												12			9	7																																																																																						
AVAILABLE	NOT APPLICABLE	34566-1383	G	0	B	ST GR	<table border="1"> <tr><td></td><td></td><td></td><td></td><td></td><td></td><td></td><td></td><td></td><td></td><td></td><td></td><td></td><td></td><td></td><td></td><td>59</td><td>58</td><td>57</td><td>55</td><td>53</td></tr> <tr><td></td><td></td><td></td><td></td><td></td><td></td><td></td><td></td><td></td><td></td><td>49</td><td>48</td><td>47</td><td>46</td><td></td><td></td><td>39</td><td>38</td><td>37</td><td>35</td><td>33</td></tr> <tr><td></td><td></td><td></td><td></td><td></td><td></td><td></td><td></td><td></td><td></td><td></td><td></td><td></td><td>29</td><td></td><td></td><td>23</td><td>22</td><td>21</td><td></td><td>17</td></tr> <tr><td></td><td></td><td></td><td></td><td></td><td></td><td></td><td></td><td></td><td></td><td></td><td></td><td></td><td>12</td><td></td><td></td><td>7</td><td></td><td></td><td></td><td></td></tr> </table>																	59	58	57	55	53											49	48	47	46			39	38	37	35	33														29			23	22	21		17														12			7															
																59	58	57	55	53																																																																																		
										49	48	47	46			39	38	37	35	33																																																																																		
													29			23	22	21		17																																																																																		
													12			7																																																																																						
AVAILABLE	NOT APPLICABLE	34566-1393	G	0	A	BLACK	<table border="1"> <tr><td></td><td></td><td></td><td></td><td></td><td></td><td></td><td></td><td></td><td></td><td></td><td></td><td></td><td></td><td></td><td></td><td></td><td>58</td><td>57</td><td>55</td><td>54</td></tr> <tr><td></td><td></td><td></td><td></td><td></td><td></td><td></td><td></td><td></td><td></td><td></td><td></td><td></td><td></td><td></td><td></td><td></td><td>39</td><td>37</td><td></td><td>34</td></tr> <tr><td></td><td></td><td></td><td></td><td></td><td></td><td></td><td></td><td></td><td></td><td></td><td></td><td></td><td></td><td></td><td></td><td></td><td></td><td></td><td>20</td><td>19</td><td>18</td></tr> <tr><td></td><td></td><td></td><td></td><td></td><td></td><td></td><td></td><td></td><td></td><td></td><td></td><td></td><td></td><td></td><td></td><td></td><td>6</td><td>5</td><td>3</td><td></td><td>1</td></tr> </table>																		58	57	55	54																		39	37		34																				20	19	18																		6	5	3		1									
																	58	57	55	54																																																																																		
																	39	37		34																																																																																		
																			20	19	18																																																																																	
																	6	5	3		1																																																																																	
AVAILABLE	NOT APPLICABLE	34566-1423	G	0	B	ST GR	<table border="1"> <tr><td></td><td></td><td></td><td></td><td></td><td></td><td></td><td></td><td></td><td></td><td></td><td></td><td></td><td></td><td></td><td></td><td></td><td></td><td></td><td></td><td>54</td><td>53</td></tr> <tr><td></td><td></td><td></td><td></td><td></td><td></td><td></td><td></td><td></td><td></td><td></td><td></td><td></td><td></td><td></td><td></td><td></td><td></td><td></td><td></td><td></td><td>34</td><td>33</td></tr> <tr><td></td><td></td><td></td><td></td><td></td><td></td><td></td><td></td><td></td><td></td><td></td><td></td><td></td><td></td><td></td><td></td><td></td><td></td><td></td><td></td><td></td><td>20</td><td>18</td></tr> <tr><td></td><td></td><td></td><td></td><td></td><td></td><td></td><td></td><td></td><td></td><td></td><td></td><td></td><td></td><td></td><td></td><td></td><td></td><td></td><td></td><td></td><td></td><td></td></tr> </table>																					54	53																						34	33																						20	18																											
																				54	53																																																																																	
																					34	33																																																																																
																					20	18																																																																																
AVAILABLE	NOT APPLICABLE	34566-1433	G	0	B	ST GR	<table border="1"> <tr><td></td><td></td><td></td><td></td><td></td><td></td><td></td><td></td><td></td><td></td><td></td><td></td><td></td><td></td><td></td><td></td><td></td><td></td><td></td><td></td><td></td><td>54</td><td>53</td></tr> <tr><td></td><td></td><td></td><td></td><td></td><td></td><td></td><td></td><td></td><td></td><td></td><td></td><td></td><td></td><td></td><td></td><td></td><td></td><td></td><td></td><td></td><td></td><td>34</td><td>33</td></tr> <tr><td></td><td></td><td></td><td></td><td></td><td></td><td></td><td></td><td></td><td></td><td></td><td></td><td></td><td></td><td></td><td></td><td></td><td></td><td></td><td></td><td></td><td></td><td>20</td><td>18</td></tr> <tr><td></td><td></td><td></td><td></td><td></td><td></td><td></td><td></td><td></td><td></td><td></td><td></td><td></td><td></td><td></td><td></td><td></td><td></td><td></td><td></td><td></td><td></td><td></td><td></td></tr> </table>																						54	53																							34	33																							20	18																								
																					54	53																																																																																
																						34	33																																																																															
																						20	18																																																																															
AVAILABLE	NOT APPLICABLE	34566-1443	G	0	B	ST GR	<table border="1"> <tr><td></td><td></td><td></td><td></td><td></td><td></td><td></td><td></td><td></td><td></td><td></td><td></td><td></td><td></td><td></td><td></td><td></td><td></td><td></td><td></td><td></td><td></td><td>53</td></tr> <tr><td></td><td></td><td></td><td></td><td></td><td></td><td></td><td></td><td></td><td></td><td></td><td></td><td></td><td></td><td></td><td></td><td></td><td></td><td></td><td></td><td></td><td></td><td></td><td>33</td></tr> <tr><td></td><td></td><td></td><td></td><td></td><td></td><td></td><td></td><td></td><td></td><td></td><td></td><td></td><td></td><td></td><td></td><td></td><td></td><td></td><td></td><td></td><td></td><td></td><td>17</td></tr> </table>																							53																								33																								17																								
																						53																																																																																
																							33																																																																															
																							17																																																																															
AVAILABLE	NOT APPLICABLE	34566-1453	G	0	B	ST GR	<table border="1"> <tr><td></td><td></td><td></td><td></td><td></td><td></td><td></td><td></td><td></td><td></td><td></td><td></td><td></td><td></td><td></td><td></td><td></td><td></td><td></td><td></td><td></td><td></td><td>53</td></tr> <tr><td></td><td></td><td></td><td></td><td></td><td></td><td></td><td></td><td></td><td></td><td></td><td></td><td></td><td></td><td></td><td></td><td></td><td></td><td></td><td></td><td></td><td></td><td>33</td></tr> <tr><td></td><td></td><td></td><td></td><td></td><td></td><td></td><td></td><td></td><td></td><td></td><td></td><td></td><td></td><td></td><td></td><td></td><td></td><td></td><td></td><td></td><td></td><td>17</td></tr> </table>																							53																							33																							17																										
																						53																																																																																
																						33																																																																																
																						17																																																																																
AVAILABLE	NOT APPLICABLE	34566-1463	G	0	A	BLACK	<table border="1"> <tr><td></td><td></td><td></td><td></td><td></td><td></td><td></td><td></td><td></td><td></td><td></td><td></td><td></td><td></td><td></td><td></td><td></td><td></td><td></td><td></td><td></td><td></td><td>53</td></tr> <tr><td></td><td></td><td></td><td></td><td></td><td></td><td></td><td></td><td></td><td></td><td></td><td></td><td></td><td></td><td></td><td></td><td></td><td></td><td></td><td></td><td></td><td></td><td>33</td></tr> <tr><td></td><td></td><td></td><td></td><td></td><td></td><td></td><td></td><td></td><td></td><td></td><td></td><td></td><td></td><td></td><td></td><td></td><td></td><td></td><td></td><td></td><td></td><td>17</td></tr> </table>																							53																							33																							17																										
																						53																																																																																
																						33																																																																																
																						17																																																																																

ENTER DESCRIPTION EC NO: UAU2013-0662 DRAWN BY: 2012/11/01 CHKD: APPR: WOSHY REV: F86	QUALITY SYMBOLS ∇=0 ∇=0 ∇=0	GENERAL TOLERANCES (UNLESS SPECIFIED) mm INCH 4 PLACES +---+--- 3 PLACES +---+--- 2 PLACES +---+--- 1 PLACE +---+--- 0 PLACE +---+---	DIMENSION STYLE MM ONLY	SCALE DESIGN UNITS METRIC	THIRD ANGLE PROJECTION	
	DRAWN BY: SKRA JENDRANA 2011/02/14 CHECKED BY: MYANSLAMBROU 2011/02/14 APPROVED BY:	DATE:	DATE:	DATE:	TITLE:	MX123 66/73/80CKT HRNS CONN ASSY
	MATERIAL NO. DOCUMENT NO.	SEE BOM TABLE	SD-34566-001	SHEET NO. 19 OF 59	THIS DRAWING CONTAINS INFORMATION THAT IS PROPRIETARY TO MOLEX INCORPORATED AND SHOULD NOT BE USED WITHOUT WRITTEN PERMISSION	SIZE D
	ANGULAR ±---° DRAFT WHERE APPLICABLE MUST REMAIN WITHIN DIMENSIONS	SEE BOM TABLE	SD-34566-001	SHEET NO. 19 OF 59	THIS DRAWING CONTAINS INFORMATION THAT IS PROPRIETARY TO MOLEX INCORPORATED AND SHOULD NOT BE USED WITHOUT WRITTEN PERMISSION	SIZE D

STATUS	GM PART #	MATERIAL #	PART/MATERIAL REVISION	WIRE DRESS OPTION	KEY OPTION	COLOR (TPA)	NUMBERS INDICATE CAVITIES OPEN FOR CIRCUITS																																																																									
AVAILABLE	NOT APPLICABLE	34566-1473	G	0	A	BLACK	<table border="1"> <tr><td>72</td><td>71</td><td>69</td><td>68</td><td>67</td><td>66</td><td>64</td><td>63</td><td>62</td><td>59</td><td></td><td></td><td></td><td></td><td>54</td><td>53</td></tr> <tr><td>52</td><td></td><td>49</td><td>48</td><td>46</td><td>44</td><td>43</td><td>42</td><td></td><td>39</td><td></td><td></td><td></td><td></td><td>34</td><td>33</td></tr> <tr><td></td><td>73</td><td></td><td>32</td><td></td><td>29</td><td>27</td><td></td><td></td><td>24</td><td>23</td><td></td><td></td><td></td><td></td><td>17</td></tr> <tr><td></td><td></td><td></td><td></td><td>14</td><td>13</td><td>12</td><td>11</td><td></td><td>9</td><td>8</td><td>7</td><td>6</td><td>5</td><td>4</td><td>3</td><td>2</td><td>1</td></tr> </table>	72	71	69	68	67	66	64	63	62	59					54	53	52		49	48	46	44	43	42		39					34	33		73		32		29	27			24	23					17					14	13	12	11		9	8	7	6	5	4	3	2	1							
72	71	69	68	67	66	64	63	62	59					54	53																																																																	
52		49	48	46	44	43	42		39					34	33																																																																	
	73		32		29	27			24	23					17																																																																	
				14	13	12	11		9	8	7	6	5	4	3	2	1																																																															
AVAILABLE	NOT APPLICABLE	34566-1483	G	0	A	BLACK	<table border="1"> <tr><td>72</td><td>71</td><td>69</td><td>68</td><td></td><td></td><td>65</td><td>64</td><td>63</td><td>61</td><td>59</td><td>58</td><td></td><td></td><td>56</td><td></td><td></td><td></td></tr> <tr><td>52</td><td></td><td>50</td><td>49</td><td></td><td>47</td><td></td><td></td><td></td><td>41</td><td></td><td></td><td></td><td></td><td>38</td><td>37</td><td>36</td><td>34</td><td>33</td></tr> <tr><td></td><td>73</td><td></td><td>32</td><td>31</td><td>30</td><td>29</td><td>28</td><td>27</td><td></td><td>24</td><td>23</td><td></td><td></td><td>20</td><td>19</td><td>18</td><td>17</td></tr> <tr><td></td><td></td><td></td><td>16</td><td></td><td></td><td>13</td><td>12</td><td>11</td><td>10</td><td>9</td><td></td><td></td><td></td><td></td><td></td><td></td><td>1</td></tr> </table>	72	71	69	68			65	64	63	61	59	58			56				52		50	49		47				41					38	37	36	34	33		73		32	31	30	29	28	27		24	23			20	19	18	17				16			13	12	11	10	9							1
72	71	69	68			65	64	63	61	59	58			56																																																																		
52		50	49		47				41					38	37	36	34	33																																																														
	73		32	31	30	29	28	27		24	23			20	19	18	17																																																															
			16			13	12	11	10	9							1																																																															
AVAILABLE	NOT APPLICABLE	34566-1493	G	0	B	ST GRAY	<table border="1"> <tr><td></td><td></td><td></td><td>68</td><td></td><td></td><td></td><td></td><td></td><td></td><td>59</td><td>58</td><td>57</td><td></td><td>55</td><td>53</td></tr> <tr><td></td><td></td><td>49</td><td>48</td><td>46</td><td></td><td></td><td></td><td></td><td></td><td>39</td><td>38</td><td>37</td><td></td><td>35</td><td>33</td></tr> <tr><td></td><td>73</td><td></td><td></td><td></td><td>29</td><td></td><td></td><td></td><td></td><td>23</td><td>22</td><td>21</td><td></td><td></td><td>18</td><td>17</td></tr> <tr><td></td><td></td><td></td><td></td><td></td><td></td><td>12</td><td>11</td><td>10</td><td></td><td>7</td><td></td><td></td><td></td><td></td><td></td><td></td><td>1</td></tr> </table>				68							59	58	57		55	53			49	48	46						39	38	37		35	33		73				29					23	22	21			18	17							12	11	10		7							1						
			68							59	58	57		55	53																																																																	
		49	48	46						39	38	37		35	33																																																																	
	73				29					23	22	21			18	17																																																																
						12	11	10		7							1																																																															
AVAILABLE	NOT APPLICABLE	34566-1513	G	0	B	ST GRAY	<table border="1"> <tr><td></td><td></td><td></td><td></td><td></td><td></td><td>65</td><td></td><td></td><td></td><td>59</td><td></td><td>57</td><td></td><td>55</td><td>53</td></tr> <tr><td></td><td></td><td>49</td><td>48</td><td>46</td><td></td><td></td><td></td><td></td><td></td><td>39</td><td></td><td>37</td><td></td><td>35</td><td>33</td></tr> <tr><td></td><td>73</td><td></td><td></td><td></td><td>29</td><td></td><td></td><td></td><td></td><td>23</td><td></td><td>21</td><td></td><td></td><td>18</td><td>17</td></tr> <tr><td></td><td></td><td></td><td></td><td></td><td></td><td>12</td><td></td><td></td><td></td><td>7</td><td></td><td></td><td></td><td></td><td></td><td></td><td>1</td></tr> </table>							65				59		57		55	53			49	48	46						39		37		35	33		73				29					23		21			18	17							12				7							1						
						65				59		57		55	53																																																																	
		49	48	46						39		37		35	33																																																																	
	73				29					23		21			18	17																																																																
						12				7							1																																																															
AVAILABLE	NOT APPLICABLE	34566-1523	G	0	A	BLACK	<table border="1"> <tr><td></td><td></td><td>70</td><td>69</td><td>68</td><td></td><td>65</td><td>64</td><td></td><td></td><td>59</td><td>58</td><td></td><td></td><td>56</td><td>54</td></tr> <tr><td>52</td><td></td><td>50</td><td>49</td><td></td><td>47</td><td></td><td></td><td>42</td><td>41</td><td></td><td></td><td></td><td></td><td>38</td><td>37</td><td>36</td><td>34</td></tr> <tr><td></td><td>73</td><td></td><td>32</td><td>31</td><td>30</td><td>29</td><td>28</td><td>27</td><td>26</td><td></td><td>23</td><td></td><td></td><td>20</td><td>19</td><td>18</td><td>17</td></tr> <tr><td></td><td></td><td></td><td>16</td><td></td><td></td><td>13</td><td>12</td><td>11</td><td>10</td><td>9</td><td>8</td><td></td><td></td><td></td><td></td><td></td><td>1</td></tr> </table>			70	69	68		65	64			59	58			56	54	52		50	49		47			42	41					38	37	36	34		73		32	31	30	29	28	27	26		23			20	19	18	17				16			13	12	11	10	9	8						1			
		70	69	68		65	64			59	58			56	54																																																																	
52		50	49		47			42	41					38	37	36	34																																																															
	73		32	31	30	29	28	27	26		23			20	19	18	17																																																															
			16			13	12	11	10	9	8						1																																																															
AVAILABLE	NOT APPLICABLE	34566-1533	G	0	A	BLACK	<table border="1"> <tr><td>72</td><td>71</td><td>70</td><td>69</td><td>68</td><td></td><td>65</td><td>64</td><td>63</td><td>61</td><td>59</td><td>58</td><td>57</td><td>56</td><td></td><td></td><td></td><td></td></tr> <tr><td>52</td><td>51</td><td>50</td><td>49</td><td></td><td>47</td><td></td><td></td><td></td><td>41</td><td></td><td></td><td></td><td>38</td><td>37</td><td>36</td><td>34</td><td>33</td></tr> <tr><td></td><td>73</td><td></td><td>32</td><td>31</td><td>30</td><td>29</td><td>28</td><td>27</td><td></td><td>24</td><td>23</td><td></td><td></td><td>20</td><td>19</td><td>18</td><td>17</td></tr> <tr><td></td><td></td><td></td><td>16</td><td></td><td></td><td>13</td><td>12</td><td>11</td><td>10</td><td>9</td><td></td><td></td><td></td><td></td><td>3</td><td>2</td><td>1</td></tr> </table>	72	71	70	69	68		65	64	63	61	59	58	57	56					52	51	50	49		47				41				38	37	36	34	33		73		32	31	30	29	28	27		24	23			20	19	18	17				16			13	12	11	10	9					3	2	1	
72	71	70	69	68		65	64	63	61	59	58	57	56																																																																			
52	51	50	49		47				41				38	37	36	34	33																																																															
	73		32	31	30	29	28	27		24	23			20	19	18	17																																																															
			16			13	12	11	10	9					3	2	1																																																															
AVAILABLE	NOT APPLICABLE	34566-1543	G	0	B	ST GRAY	<table border="1"> <tr><td></td><td></td><td></td><td>69</td><td>68</td><td>66</td><td></td><td></td><td></td><td></td><td>59</td><td></td><td>57</td><td></td><td>55</td><td>53</td></tr> <tr><td></td><td></td><td>49</td><td>48</td><td>46</td><td></td><td></td><td></td><td></td><td></td><td>39</td><td></td><td>37</td><td></td><td>35</td><td>33</td></tr> <tr><td></td><td>73</td><td></td><td></td><td></td><td>29</td><td></td><td></td><td></td><td></td><td>23</td><td></td><td>21</td><td></td><td></td><td></td><td></td><td></td></tr> <tr><td></td><td></td><td></td><td></td><td></td><td></td><td></td><td></td><td>11</td><td>10</td><td></td><td>7</td><td></td><td></td><td></td><td></td><td></td><td></td></tr> </table>				69	68	66					59		57		55	53			49	48	46						39		37		35	33		73				29					23		21														11	10		7											
			69	68	66					59		57		55	53																																																																	
		49	48	46						39		37		35	33																																																																	
	73				29					23		21																																																																				
								11	10		7																																																																					
AVAILABLE	NOT APPLICABLE	34566-1583	G	0	A	BLACK	<table border="1"> <tr><td></td><td></td><td>70</td><td></td><td>67</td><td>66</td><td>65</td><td></td><td></td><td>61</td><td></td><td></td><td>58</td><td>57</td><td></td><td>55</td><td>54</td></tr> <tr><td></td><td></td><td>49</td><td></td><td>47</td><td>45</td><td>44</td><td>43</td><td>42</td><td>41</td><td></td><td>39</td><td></td><td>37</td><td></td><td>34</td><td></td></tr> <tr><td></td><td>73</td><td></td><td>32</td><td>30</td><td></td><td>27</td><td>25</td><td>24</td><td></td><td></td><td>21</td><td>20</td><td>19</td><td>18</td><td>17</td><td></td><td></td></tr> <tr><td></td><td></td><td></td><td>15</td><td></td><td>13</td><td></td><td>11</td><td>9</td><td>8</td><td></td><td>6</td><td>5</td><td></td><td>3</td><td></td><td></td><td>1</td></tr> </table>			70		67	66	65			61			58	57		55	54			49		47	45	44	43	42	41		39		37		34			73		32	30		27	25	24			21	20	19	18	17						15		13		11	9	8		6	5		3			1			
		70		67	66	65			61			58	57		55	54																																																																
		49		47	45	44	43	42	41		39		37		34																																																																	
	73		32	30		27	25	24			21	20	19	18	17																																																																	
			15		13		11	9	8		6	5		3			1																																																															

ENTER DESCRIPTION EC NO: UAU2013-0662 DRAWN BY: CHYD CHKD: APPR: IKOSHY 2012/11/21 REV:	QUALITY SYMBOLS ∇=0 ∇=0 ∇=0	GENERAL TOLERANCES (UNLESS SPECIFIED) DIMENSION STYLE MM ONLY	SCALE DESIGN UNITS METRIC	THIRD ANGLE PROJECTION	
	4 PLACES ±---+--- 3 PLACES ±---+--- 2 PLACES ±---+--- 1 PLACE ±---+--- 0 PLACE ±---+---	mm INCH SKRAJENDRANA 2011/02/14 MYANSLAMBROU 2011/02/14	DRAWN BY DATE CHECKED BY DATE APPROVED BY DATE	TITLE MX123 66/73/80CKT HRNS CONN ASSY	MOLEX
	ANGULAR ±---° DRAFT WHERE APPLICABLE MUST REMAIN WITHIN DIMENSIONS	SEE BOM TABLE	MATERIAL NO. DOCUMENT NO.	SD-34566-001	SHEET NO. 20 OF 59
	THIS DRAWING CONTAINS INFORMATION THAT IS PROPRIETARY TO MOLEX INCORPORATED AND SHOULD NOT BE USED WITHOUT WRITTEN PERMISSION				

20 19 18 17 16 15 14 13 12 11 10 9 8 7 6 5 4 3 2 1

STATUS	GM PART #	MATERIAL #	PART/MATERIAL REVISION	WIRE DRESS OPTION	KEY OPTION	COLOR (TPA)	NUMBERS INDICATE CAVITIES OPEN FOR CIRCUITS																																																																				
AVAILABLE	NOT APPLICABLE	34566-1693	G	0	B	ST GRAY	<table border="1"> <tr><td></td><td></td><td></td><td></td><td>66</td><td>64</td><td></td><td></td><td></td><td></td><td>59</td><td>57</td><td>55</td><td>53</td></tr> <tr><td></td><td></td><td>49</td><td>48</td><td>46</td><td></td><td></td><td></td><td></td><td></td><td>39</td><td>37</td><td>35</td><td>33</td></tr> <tr><td>73</td><td></td><td>32</td><td></td><td>29</td><td></td><td></td><td></td><td></td><td></td><td>23</td><td>21</td><td></td><td>17</td></tr> <tr><td></td><td></td><td></td><td></td><td></td><td>12</td><td></td><td></td><td></td><td></td><td>7</td><td></td><td></td><td></td></tr> </table>					66	64					59	57	55	53			49	48	46						39	37	35	33	73		32		29						23	21		17						12					7															
				66	64					59	57	55	53																																																														
		49	48	46						39	37	35	33																																																														
73		32		29						23	21		17																																																														
					12					7																																																																	
AVAILABLE	NOT APPLICABLE	34566-1713	G	0	B	ST GRAY	<table border="1"> <tr><td>71</td><td>70</td><td>68</td><td>66</td><td>65</td><td>64</td><td>63</td><td></td><td></td><td>60</td><td>59</td><td>58</td><td>57</td><td>56</td><td>55</td><td>54</td><td>53</td></tr> <tr><td>51</td><td>50</td><td>49</td><td>48</td><td>46</td><td>45</td><td>43</td><td></td><td>41</td><td>40</td><td>39</td><td>38</td><td>37</td><td>36</td><td>35</td><td>33</td><td></td></tr> <tr><td>73</td><td></td><td>32</td><td>31</td><td>30</td><td></td><td></td><td></td><td></td><td>24</td><td>23</td><td>22</td><td></td><td>20</td><td>19</td><td></td><td></td></tr> <tr><td></td><td></td><td>16</td><td>15</td><td></td><td>13</td><td>12</td><td>11</td><td>10</td><td>9</td><td>8</td><td>7</td><td>6</td><td>5</td><td>4</td><td>3</td><td>2</td></tr> </table>	71	70	68	66	65	64	63			60	59	58	57	56	55	54	53	51	50	49	48	46	45	43		41	40	39	38	37	36	35	33		73		32	31	30					24	23	22		20	19					16	15		13	12	11	10	9	8	7	6	5	4	3	2
71	70	68	66	65	64	63			60	59	58	57	56	55	54	53																																																											
51	50	49	48	46	45	43		41	40	39	38	37	36	35	33																																																												
73		32	31	30					24	23	22		20	19																																																													
		16	15		13	12	11	10	9	8	7	6	5	4	3	2																																																											
AVAILABLE	NOT APPLICABLE	34566-1723	G	0	B	ST GRAY	<table border="1"> <tr><td>71</td><td>70</td><td>68</td><td>66</td><td>65</td><td></td><td></td><td></td><td></td><td>60</td><td>59</td><td>58</td><td>57</td><td></td><td></td><td>54</td><td>53</td></tr> <tr><td>51</td><td>50</td><td>49</td><td>48</td><td>46</td><td>45</td><td>43</td><td></td><td>41</td><td>40</td><td>39</td><td>38</td><td>37</td><td>36</td><td>35</td><td></td><td>33</td></tr> <tr><td>73</td><td></td><td>32</td><td>31</td><td>30</td><td></td><td></td><td></td><td></td><td>24</td><td>23</td><td>22</td><td></td><td>20</td><td></td><td></td><td></td></tr> <tr><td></td><td></td><td>16</td><td>15</td><td></td><td>13</td><td>12</td><td>11</td><td>10</td><td>9</td><td>8</td><td>7</td><td>6</td><td>5</td><td>4</td><td></td><td></td></tr> </table>	71	70	68	66	65					60	59	58	57			54	53	51	50	49	48	46	45	43		41	40	39	38	37	36	35		33	73		32	31	30					24	23	22		20						16	15		13	12	11	10	9	8	7	6	5	4		
71	70	68	66	65					60	59	58	57			54	53																																																											
51	50	49	48	46	45	43		41	40	39	38	37	36	35		33																																																											
73		32	31	30					24	23	22		20																																																														
		16	15		13	12	11	10	9	8	7	6	5	4																																																													
AVAILABLE	NOT APPLICABLE	34566-1733	G	0	A	BLACK	<table border="1"> <tr><td></td><td>70</td><td>68</td><td>67</td><td>66</td><td>65</td><td></td><td></td><td></td><td></td><td></td><td></td><td>58</td><td>57</td><td>55</td><td></td><td></td></tr> <tr><td></td><td>49</td><td>47</td><td></td><td></td><td>44</td><td>43</td><td>42</td><td>41</td><td></td><td>39</td><td></td><td>37</td><td>35</td><td></td><td></td><td></td></tr> <tr><td>73</td><td></td><td>32</td><td></td><td>30</td><td></td><td></td><td>27</td><td>25</td><td>24</td><td></td><td></td><td>21</td><td>20</td><td>19</td><td>18</td><td>17</td></tr> <tr><td></td><td></td><td>16</td><td>15</td><td></td><td>13</td><td></td><td>10</td><td>9</td><td>8</td><td></td><td>6</td><td>5</td><td></td><td>3</td><td>2</td><td>1</td></tr> </table>		70	68	67	66	65							58	57	55				49	47			44	43	42	41		39		37	35				73		32		30			27	25	24			21	20	19	18	17			16	15		13		10	9	8		6	5		3	2	1
	70	68	67	66	65							58	57	55																																																													
	49	47			44	43	42	41		39		37	35																																																														
73		32		30			27	25	24			21	20	19	18	17																																																											
		16	15		13		10	9	8		6	5		3	2	1																																																											
AVAILABLE	NOT APPLICABLE	34566-1743	G	0	A	BLACK	<table border="1"> <tr><td></td><td>70</td><td></td><td>67</td><td>66</td><td>65</td><td></td><td></td><td></td><td></td><td></td><td></td><td>58</td><td>57</td><td>55</td><td></td><td></td></tr> <tr><td></td><td>49</td><td></td><td>47</td><td></td><td>44</td><td>43</td><td>42</td><td>41</td><td></td><td>39</td><td></td><td>37</td><td>35</td><td></td><td></td><td></td></tr> <tr><td>73</td><td></td><td>32</td><td></td><td>30</td><td></td><td></td><td>27</td><td>25</td><td>24</td><td></td><td></td><td>21</td><td>20</td><td>19</td><td>18</td><td>17</td></tr> <tr><td></td><td></td><td>16</td><td>15</td><td></td><td>13</td><td></td><td>10</td><td>9</td><td>8</td><td></td><td>6</td><td>5</td><td></td><td>3</td><td>2</td><td>1</td></tr> </table>		70		67	66	65							58	57	55				49		47		44	43	42	41		39		37	35				73		32		30			27	25	24			21	20	19	18	17			16	15		13		10	9	8		6	5		3	2	1
	70		67	66	65							58	57	55																																																													
	49		47		44	43	42	41		39		37	35																																																														
73		32		30			27	25	24			21	20	19	18	17																																																											
		16	15		13		10	9	8		6	5		3	2	1																																																											
AVAILABLE	NOT APPLICABLE	34566-1753	G	0	A	BLACK	<table border="1"> <tr><td></td><td>70</td><td></td><td>67</td><td>66</td><td>65</td><td></td><td></td><td></td><td></td><td></td><td></td><td>58</td><td>57</td><td>55</td><td></td><td></td></tr> <tr><td></td><td>49</td><td></td><td>47</td><td></td><td>44</td><td>43</td><td>42</td><td>41</td><td></td><td>39</td><td></td><td>37</td><td>35</td><td></td><td></td><td></td></tr> <tr><td>73</td><td></td><td>32</td><td></td><td></td><td></td><td>27</td><td>25</td><td>24</td><td></td><td></td><td></td><td>21</td><td>20</td><td>19</td><td>18</td><td>17</td></tr> <tr><td></td><td></td><td></td><td>15</td><td></td><td>13</td><td></td><td></td><td>9</td><td>8</td><td></td><td>6</td><td>5</td><td></td><td>3</td><td></td><td>1</td></tr> </table>		70		67	66	65							58	57	55				49		47		44	43	42	41		39		37	35				73		32				27	25	24				21	20	19	18	17				15		13			9	8		6	5		3		1
	70		67	66	65							58	57	55																																																													
	49		47		44	43	42	41		39		37	35																																																														
73		32				27	25	24				21	20	19	18	17																																																											
			15		13			9	8		6	5		3		1																																																											
AVAILABLE	NOT APPLICABLE	34566-1763	G	0	B	ST GRAY	<table border="1"> <tr><td></td><td></td><td></td><td>67</td><td>65</td><td></td><td></td><td></td><td>61</td><td>60</td><td>59</td><td>58</td><td>57</td><td></td><td></td><td>54</td><td>53</td></tr> <tr><td>51</td><td>50</td><td>49</td><td>48</td><td>47</td><td>46</td><td>45</td><td>43</td><td></td><td>40</td><td>39</td><td></td><td>37</td><td></td><td></td><td>34</td><td>33</td></tr> <tr><td>73</td><td></td><td></td><td>32</td><td>31</td><td>30</td><td></td><td></td><td></td><td>26</td><td>24</td><td>23</td><td>22</td><td>21</td><td>20</td><td></td><td></td></tr> <tr><td></td><td></td><td></td><td>16</td><td>15</td><td>14</td><td>13</td><td></td><td>10</td><td>9</td><td>8</td><td>7</td><td>6</td><td>5</td><td>4</td><td></td><td></td></tr> </table>				67	65				61	60	59	58	57			54	53	51	50	49	48	47	46	45	43		40	39		37			34	33	73			32	31	30				26	24	23	22	21	20						16	15	14	13		10	9	8	7	6	5	4		
			67	65				61	60	59	58	57			54	53																																																											
51	50	49	48	47	46	45	43		40	39		37			34	33																																																											
73			32	31	30				26	24	23	22	21	20																																																													
			16	15	14	13		10	9	8	7	6	5	4																																																													

ENTER DESCRIPTION EC NO: UAU2013-0662 DRAWN BY: CHYKD APPR: WOSHY 2012/11/21 786	QUALITY SYMBOLS ∇=0 ∇=0 ∇=0	GENERAL TOLERANCES (UNLESS SPECIFIED) <table border="1"> <tr><th></th><th>mm</th><th>INCH</th></tr> <tr><td>4 PLACES</td><td>±----</td><td>±----</td></tr> <tr><td>3 PLACES</td><td>±----</td><td>±----</td></tr> <tr><td>2 PLACES</td><td>±----</td><td>±----</td></tr> <tr><td>1 PLACE</td><td>±----</td><td>±----</td></tr> <tr><td>0 PLACE</td><td>±----</td><td>±----</td></tr> </table>		mm	INCH	4 PLACES	±----	±----	3 PLACES	±----	±----	2 PLACES	±----	±----	1 PLACE	±----	±----	0 PLACE	±----	±----	DIMENSION STYLE MM ONLY	SCALE METRIC	DESIGN UNITS METRIC	THIRD ANGLE PROJECTION
		mm	INCH																					
	4 PLACES	±----	±----																					
	3 PLACES	±----	±----																					
2 PLACES	±----	±----																						
1 PLACE	±----	±----																						
0 PLACE	±----	±----																						
DRAWN BY SKRAJENDRANA DATE 2011/02/14 CHECKED BY MVANSLAMBROU DATE 2011/02/14 APPROVED BY	TITLE MX123 66/73/80CKT HRNS CONN ASSY molex	MATERIAL NO. SEE BOM TABLE	DOCUMENT NO. SD-34566-001	SHEET NO. 22 OF 59																				
DRAFT WHERE APPLICABLE MUST REMAIN WITHIN DIMENSIONS																								
THIS DRAWING CONTAINS INFORMATION THAT IS PROPRIETARY TO MOLEX INCORPORATED AND SHOULD NOT BE USED WITHOUT WRITTEN PERMISSION																								

19 18 17 16 15 14 13 12 11 10 9 8 7 6 5 4 3 2 1

STATUS	GM PART #	MATERIAL #	PART/MATERIAL REVISION	WIRE DRESS OPTION	KEY OPTION	COLOR (TPA)	NUMBERS INDICATE CAVITIES OPEN FOR CIRCUITS																																																																														
AVAILABLE	NOT APPLICABLE	34566-1973	G	0	A	BLACK	<table border="1"> <tr><td></td><td></td><td>69</td><td></td><td></td><td></td><td>63</td><td></td><td></td><td></td><td></td><td></td><td>56</td><td>55</td><td>54</td><td>53</td></tr> <tr><td>52</td><td>51</td><td>49</td><td></td><td></td><td></td><td>44</td><td>43</td><td>42</td><td>41</td><td></td><td></td><td></td><td>36</td><td>35</td><td>34</td><td>33</td></tr> <tr><td></td><td></td><td>73</td><td></td><td>32</td><td></td><td>28</td><td>26</td><td></td><td>23</td><td></td><td>21</td><td>19</td><td>18</td><td></td><td></td></tr> <tr><td></td><td></td><td></td><td></td><td>16</td><td></td><td>12</td><td>10</td><td>8</td><td></td><td>5</td><td>3</td><td></td><td></td><td></td><td></td></tr> </table>			69				63						56	55	54	53	52	51	49				44	43	42	41				36	35	34	33			73		32		28	26		23		21	19	18							16		12	10	8		5	3																	
		69				63						56	55	54	53																																																																						
52	51	49				44	43	42	41				36	35	34	33																																																																					
		73		32		28	26		23		21	19	18																																																																								
				16		12	10	8		5	3																																																																										
AVAILABLE	NOT APPLICABLE	34566-2013	G	0	A	BLACK	<table border="1"> <tr><td></td><td>71</td><td>70</td><td></td><td></td><td></td><td>65</td><td></td><td></td><td></td><td></td><td>60</td><td>59</td><td>58</td><td>57</td><td></td><td>54</td><td>53</td></tr> <tr><td>51</td><td>50</td><td>49</td><td>48</td><td>46</td><td>45</td><td>43</td><td>41</td><td>40</td><td>39</td><td></td><td>37</td><td>36</td><td>35</td><td></td><td></td><td></td><td>33</td></tr> <tr><td></td><td></td><td>73</td><td></td><td>32</td><td>31</td><td>30</td><td></td><td></td><td></td><td>24</td><td>23</td><td>22</td><td></td><td>20</td><td></td><td></td><td></td></tr> <tr><td></td><td></td><td></td><td></td><td>16</td><td>15</td><td>13</td><td>12</td><td>11</td><td>10</td><td>9</td><td>8</td><td>7</td><td>6</td><td>5</td><td>4</td><td></td><td></td></tr> </table>		71	70				65					60	59	58	57		54	53	51	50	49	48	46	45	43	41	40	39		37	36	35				33			73		32	31	30				24	23	22		20								16	15	13	12	11	10	9	8	7	6	5	4								
	71	70				65					60	59	58	57		54	53																																																																				
51	50	49	48	46	45	43	41	40	39		37	36	35				33																																																																				
		73		32	31	30				24	23	22		20																																																																							
				16	15	13	12	11	10	9	8	7	6	5	4																																																																						
AVAILABLE	NOT APPLICABLE	34566-2023	G	0	A	BLACK	<table border="1"> <tr><td></td><td></td><td>70</td><td>68</td><td>67</td><td>66</td><td>65</td><td></td><td></td><td></td><td></td><td></td><td>58</td><td>57</td><td></td><td>55</td><td></td><td></td></tr> <tr><td></td><td></td><td>49</td><td></td><td>47</td><td></td><td></td><td>44</td><td>43</td><td>42</td><td>41</td><td>39</td><td>37</td><td>35</td><td></td><td></td><td></td><td></td></tr> <tr><td></td><td></td><td>73</td><td></td><td>32</td><td></td><td>30</td><td></td><td></td><td>27</td><td>25</td><td>24</td><td></td><td>21</td><td>20</td><td>19</td><td>18</td><td>17</td></tr> <tr><td></td><td></td><td></td><td></td><td></td><td>15</td><td>13</td><td></td><td></td><td>9</td><td>8</td><td></td><td>6</td><td>5</td><td></td><td>3</td><td></td><td>1</td></tr> </table>			70	68	67	66	65						58	57		55					49		47			44	43	42	41	39	37	35							73		32		30			27	25	24		21	20	19	18	17						15	13			9	8		6	5		3		1						
		70	68	67	66	65						58	57		55																																																																						
		49		47			44	43	42	41	39	37	35																																																																								
		73		32		30			27	25	24		21	20	19	18	17																																																																				
					15	13			9	8		6	5		3		1																																																																				
AVAILABLE	NOT APPLICABLE	34566-2033	G	0	A	BLACK	<table border="1"> <tr><td></td><td>71</td><td>70</td><td></td><td></td><td></td><td>65</td><td>64</td><td></td><td></td><td></td><td>60</td><td>59</td><td>58</td><td>57</td><td></td><td>55</td><td>54</td><td>53</td></tr> <tr><td>51</td><td>50</td><td>49</td><td>48</td><td>46</td><td>45</td><td>43</td><td>41</td><td>40</td><td>39</td><td></td><td>37</td><td>36</td><td>35</td><td></td><td></td><td></td><td></td><td>33</td></tr> <tr><td></td><td></td><td>73</td><td></td><td>32</td><td>31</td><td>30</td><td></td><td></td><td></td><td>24</td><td>23</td><td>22</td><td></td><td>20</td><td></td><td></td><td></td><td></td></tr> <tr><td></td><td></td><td></td><td></td><td>16</td><td>15</td><td>13</td><td>12</td><td>11</td><td>10</td><td>9</td><td>8</td><td>7</td><td>6</td><td>5</td><td>4</td><td>3</td><td>2</td><td>1</td></tr> </table>		71	70				65	64				60	59	58	57		55	54	53	51	50	49	48	46	45	43	41	40	39		37	36	35					33			73		32	31	30				24	23	22		20									16	15	13	12	11	10	9	8	7	6	5	4	3	2	1		
	71	70				65	64				60	59	58	57		55	54	53																																																																			
51	50	49	48	46	45	43	41	40	39		37	36	35					33																																																																			
		73		32	31	30				24	23	22		20																																																																							
				16	15	13	12	11	10	9	8	7	6	5	4	3	2	1																																																																			
AVAILABLE	NOT APPLICABLE	34566-2043	G	0	A	BLACK	<table border="1"> <tr><td></td><td></td><td>70</td><td></td><td>67</td><td>66</td><td>65</td><td></td><td></td><td></td><td></td><td></td><td>58</td><td>57</td><td></td><td>55</td><td></td><td></td><td></td></tr> <tr><td></td><td></td><td>49</td><td></td><td>47</td><td></td><td></td><td>44</td><td>43</td><td>42</td><td>41</td><td>39</td><td>37</td><td>35</td><td></td><td></td><td></td><td></td><td></td></tr> <tr><td></td><td></td><td>73</td><td></td><td>32</td><td></td><td>30</td><td></td><td></td><td>27</td><td>25</td><td>24</td><td></td><td>21</td><td>20</td><td>19</td><td>18</td><td>17</td><td></td></tr> <tr><td></td><td></td><td></td><td></td><td></td><td>15</td><td>13</td><td></td><td></td><td>9</td><td>8</td><td></td><td>6</td><td>5</td><td></td><td>3</td><td></td><td>1</td><td></td></tr> </table>			70		67	66	65						58	57		55						49		47			44	43	42	41	39	37	35								73		32		30			27	25	24		21	20	19	18	17							15	13			9	8		6	5		3		1			
		70		67	66	65						58	57		55																																																																						
		49		47			44	43	42	41	39	37	35																																																																								
		73		32		30			27	25	24		21	20	19	18	17																																																																				
					15	13			9	8		6	5		3		1																																																																				
AVAILABLE	NOT APPLICABLE	34566-2053	G	0	B	ST GRAY	<table border="1"> <tr><td></td><td></td><td>70</td><td>68</td><td>67</td><td>66</td><td>65</td><td></td><td></td><td></td><td></td><td></td><td>58</td><td>57</td><td></td><td>55</td><td></td><td></td><td></td></tr> <tr><td></td><td></td><td>49</td><td></td><td>47</td><td></td><td></td><td>44</td><td>43</td><td>42</td><td>41</td><td>39</td><td>37</td><td></td><td></td><td></td><td></td><td></td><td></td></tr> <tr><td></td><td></td><td>73</td><td></td><td>32</td><td></td><td>30</td><td></td><td></td><td>27</td><td>25</td><td>24</td><td>23</td><td>21</td><td>20</td><td>19</td><td>18</td><td></td><td></td></tr> <tr><td></td><td></td><td></td><td></td><td></td><td></td><td>13</td><td></td><td></td><td></td><td>8</td><td></td><td>6</td><td>5</td><td></td><td>3</td><td></td><td>1</td><td></td></tr> </table>			70	68	67	66	65						58	57		55						49		47			44	43	42	41	39	37									73		32		30			27	25	24	23	21	20	19	18									13				8		6	5		3		1			
		70	68	67	66	65						58	57		55																																																																						
		49		47			44	43	42	41	39	37																																																																									
		73		32		30			27	25	24	23	21	20	19	18																																																																					
						13				8		6	5		3		1																																																																				
AVAILABLE	NOT APPLICABLE	34566-2063	G	0	H	ST GRAY	<table border="1"> <tr><td></td><td></td><td></td><td>78</td><td></td><td></td><td></td><td></td><td>72</td><td>71</td><td>70</td><td>69</td><td>68</td><td></td><td>66</td><td>65</td><td>64</td><td>63</td><td>61</td></tr> <tr><td></td><td></td><td>58</td><td>57</td><td>56</td><td></td><td></td><td>53</td><td>52</td><td></td><td>50</td><td></td><td></td><td></td><td></td><td></td><td>44</td><td>43</td><td>41</td></tr> <tr><td>40</td><td></td><td></td><td>37</td><td></td><td>35</td><td>34</td><td></td><td>32</td><td></td><td>30</td><td>29</td><td></td><td>27</td><td>26</td><td></td><td></td><td></td><td>22</td><td>21</td></tr> <tr><td>20</td><td>19</td><td>18</td><td>17</td><td>16</td><td></td><td></td><td>14</td><td>12</td><td></td><td>10</td><td>9</td><td>8</td><td></td><td>6</td><td>5</td><td></td><td>3</td><td>2</td><td>1</td></tr> </table>				78					72	71	70	69	68		66	65	64	63	61			58	57	56			53	52		50						44	43	41	40			37		35	34		32		30	29		27	26				22	21	20	19	18	17	16			14	12		10	9	8		6	5		3	2	1
			78					72	71	70	69	68		66	65	64	63	61																																																																			
		58	57	56			53	52		50						44	43	41																																																																			
40			37		35	34		32		30	29		27	26				22	21																																																																		
20	19	18	17	16			14	12		10	9	8		6	5		3	2	1																																																																		
AVAILABLE	NOT APPLICABLE	34566-2073	G	0	H	ST GRAY	<table border="1"> <tr><td></td><td></td><td></td><td>78</td><td></td><td></td><td></td><td></td><td>72</td><td>71</td><td>70</td><td>69</td><td>68</td><td></td><td>66</td><td>65</td><td>64</td><td>63</td><td>61</td></tr> <tr><td></td><td></td><td>58</td><td>57</td><td>56</td><td></td><td></td><td>53</td><td>52</td><td></td><td>50</td><td></td><td></td><td></td><td></td><td></td><td>44</td><td>43</td><td>41</td></tr> <tr><td>40</td><td></td><td></td><td>37</td><td></td><td>35</td><td>34</td><td></td><td>32</td><td></td><td>30</td><td>29</td><td></td><td>27</td><td>26</td><td></td><td></td><td></td><td>22</td><td>21</td></tr> <tr><td>20</td><td>19</td><td>18</td><td>17</td><td>16</td><td></td><td></td><td></td><td>12</td><td></td><td></td><td></td><td>8</td><td></td><td>6</td><td>5</td><td></td><td>3</td><td>2</td><td>1</td></tr> </table>				78					72	71	70	69	68		66	65	64	63	61			58	57	56			53	52		50						44	43	41	40			37		35	34		32		30	29		27	26				22	21	20	19	18	17	16				12				8		6	5		3	2	1
			78					72	71	70	69	68		66	65	64	63	61																																																																			
		58	57	56			53	52		50						44	43	41																																																																			
40			37		35	34		32		30	29		27	26				22	21																																																																		
20	19	18	17	16				12				8		6	5		3	2	1																																																																		
AVAILABLE	NOT APPLICABLE	34566-2083	G	0	H	ST GRAY	<table border="1"> <tr><td></td><td></td><td></td><td>78</td><td></td><td></td><td></td><td></td><td>72</td><td>71</td><td>70</td><td>69</td><td>68</td><td>67</td><td>66</td><td>65</td><td>64</td><td>63</td><td>61</td></tr> <tr><td></td><td></td><td>58</td><td>57</td><td>56</td><td></td><td></td><td>53</td><td>52</td><td>51</td><td>50</td><td></td><td></td><td></td><td></td><td></td><td>44</td><td>43</td><td>41</td></tr> <tr><td>40</td><td></td><td></td><td>37</td><td></td><td>35</td><td>34</td><td></td><td>32</td><td></td><td>30</td><td>29</td><td></td><td>27</td><td>26</td><td></td><td></td><td></td><td>22</td><td>21</td></tr> <tr><td>20</td><td>19</td><td>18</td><td>17</td><td>16</td><td></td><td></td><td></td><td>12</td><td></td><td></td><td></td><td>8</td><td>7</td><td>6</td><td>5</td><td></td><td>3</td><td>2</td><td>1</td></tr> </table>				78					72	71	70	69	68	67	66	65	64	63	61			58	57	56			53	52	51	50						44	43	41	40			37		35	34		32		30	29		27	26				22	21	20	19	18	17	16				12				8	7	6	5		3	2	1
			78					72	71	70	69	68	67	66	65	64	63	61																																																																			
		58	57	56			53	52	51	50						44	43	41																																																																			
40			37		35	34		32		30	29		27	26				22	21																																																																		
20	19	18	17	16				12				8	7	6	5		3	2	1																																																																		

ENTER DESCRIPTION EC NO: UAU2013-0662 DRAWN BY: DRANKATE CHKD: APPR: IKOSHY REV: 186 DESCRIPTION: 2012/11/21	QUALITY SYMBOLS	GENERAL TOLERANCES (UNLESS SPECIFIED)	DIMENSION STYLE	SCALE	DESIGN UNITS	THIRD ANGLE PROJECTION	
	∇=0 ∇=0 ∇=0	4 PLACES ±---+--- 3 PLACES ±---+--- 2 PLACES ±---+--- 1 PLACE ±---+--- 0 PLACE ±---+---	mm INCH ±--- ±--- ±--- ±--- ±--- ±--- ±--- ±---	MM ONLY DRAWN BY: SKRAJENDRANA CHECKED BY: MYANSLAMBROU APPROVED BY:	DATE: 2011/02/14 DATE: 2011/02/14 DATE:	METRIC TITLE: MX123 66/73/80CKT HRNS CONN ASSY	M THIRD ANGLE PROJECTION
	ANGULAR ±---° DRAFT WHERE APPLICABLE MUST REMAIN WITHIN DIMENSIONS	MATERIAL NO. SEE BOM TABLE	DOCUMENT NO. SD-34566-001	SHEET NO. 25 OF 59			
	THIS DRAWING CONTAINS INFORMATION THAT IS PROPRIETARY TO MOLEX INCORPORATED AND SHOULD NOT BE USED WITHOUT WRITTEN PERMISSION						

STATUS	GM PART #	MATERIAL #	PART/MATERIAL REVISION	WIRE DRESS OPTION	KEY OPTION	COLOR (TPA)	NUMBERS INDICATE CAVITIES OPEN FOR CIRCUITS																																																																																
AVAILABLE	NOT APPLICABLE	34566-2193	G	0	A	BLACK	<table border="1"> <tr><td></td><td>70</td><td></td><td>67</td><td>66</td><td>65</td><td></td><td></td><td></td><td></td><td></td><td></td><td>58</td><td>57</td><td>55</td><td></td><td></td></tr> <tr><td></td><td></td><td>49</td><td>47</td><td></td><td></td><td>44</td><td>43</td><td>42</td><td>41</td><td></td><td>39</td><td></td><td>37</td><td></td><td>20</td><td>19</td><td>18</td><td>17</td></tr> <tr><td>73</td><td></td><td></td><td>32</td><td>30</td><td></td><td></td><td></td><td>27</td><td></td><td>25</td><td>24</td><td></td><td></td><td>21</td><td>20</td><td>19</td><td>18</td><td>17</td></tr> <tr><td></td><td></td><td></td><td></td><td>15</td><td></td><td>13</td><td></td><td></td><td></td><td>9</td><td>8</td><td></td><td>6</td><td>5</td><td></td><td>3</td><td></td><td>1</td></tr> </table>		70		67	66	65							58	57	55					49	47			44	43	42	41		39		37		20	19	18	17	73			32	30				27		25	24			21	20	19	18	17					15		13				9	8		6	5		3		1						
	70		67	66	65							58	57	55																																																																									
		49	47			44	43	42	41		39		37		20	19	18	17																																																																					
73			32	30				27		25	24			21	20	19	18	17																																																																					
				15		13				9	8		6	5		3		1																																																																					
AVAILABLE	NOT APPLICABLE	34566-2213	G	9	H	ST GRAY	<table border="1"> <tr><td></td><td>79</td><td>78</td><td>77</td><td>76</td><td>75</td><td>74</td><td>73</td><td>72</td><td>71</td><td>70</td><td>69</td><td>68</td><td></td><td>66</td><td>65</td><td>64</td><td>63</td><td></td><td>61</td></tr> <tr><td>60</td><td>59</td><td>58</td><td>57</td><td>56</td><td></td><td></td><td>53</td><td></td><td></td><td>50</td><td></td><td></td><td></td><td></td><td></td><td>44</td><td>43</td><td></td><td>41</td></tr> <tr><td>40</td><td>39</td><td>38</td><td>37</td><td></td><td>35</td><td>34</td><td>33</td><td>32</td><td></td><td>30</td><td>29</td><td></td><td>27</td><td>26</td><td></td><td>24</td><td>23</td><td></td><td>21</td></tr> <tr><td>20</td><td>19</td><td>18</td><td>17</td><td></td><td></td><td>14</td><td>13</td><td>12</td><td>11</td><td>10</td><td>9</td><td>8</td><td></td><td>6</td><td>5</td><td></td><td>3</td><td></td><td>2</td></tr> </table>		79	78	77	76	75	74	73	72	71	70	69	68		66	65	64	63		61	60	59	58	57	56			53			50						44	43		41	40	39	38	37		35	34	33	32		30	29		27	26		24	23		21	20	19	18	17			14	13	12	11	10	9	8		6	5		3		2
	79	78	77	76	75	74	73	72	71	70	69	68		66	65	64	63		61																																																																				
60	59	58	57	56			53			50						44	43		41																																																																				
40	39	38	37		35	34	33	32		30	29		27	26		24	23		21																																																																				
20	19	18	17			14	13	12	11	10	9	8		6	5		3		2																																																																				
AVAILABLE	NOT APPLICABLE	34566-2223	G	0	A	BLACK	<table border="1"> <tr><td>72</td><td>71</td><td>70</td><td>69</td><td>68</td><td>67</td><td>66</td><td></td><td>64</td><td>63</td><td>62</td><td></td><td>60</td><td>59</td><td></td><td></td><td></td><td>55</td><td>54</td><td>53</td></tr> <tr><td>52</td><td></td><td>49</td><td>48</td><td>46</td><td></td><td></td><td>44</td><td>43</td><td>42</td><td></td><td>40</td><td>39</td><td></td><td></td><td></td><td></td><td>35</td><td>34</td><td>33</td></tr> <tr><td></td><td></td><td></td><td>32</td><td></td><td></td><td></td><td></td><td>29</td><td></td><td>27</td><td></td><td>24</td><td>23</td><td></td><td></td><td></td><td>19</td><td>18</td><td>17</td></tr> <tr><td>73</td><td></td><td></td><td></td><td>16</td><td></td><td>14</td><td>13</td><td>12</td><td>11</td><td></td><td>9</td><td>8</td><td>7</td><td>6</td><td>5</td><td>4</td><td>3</td><td>2</td><td>1</td></tr> </table>	72	71	70	69	68	67	66		64	63	62		60	59				55	54	53	52		49	48	46			44	43	42		40	39					35	34	33				32					29		27		24	23				19	18	17	73				16		14	13	12	11		9	8	7	6	5	4	3	2	1
72	71	70	69	68	67	66		64	63	62		60	59				55	54	53																																																																				
52		49	48	46			44	43	42		40	39					35	34	33																																																																				
			32					29		27		24	23				19	18	17																																																																				
73				16		14	13	12	11		9	8	7	6	5	4	3	2	1																																																																				
AVAILABLE	NOT APPLICABLE	34566-2233	G	0	A	BLACK	<table border="1"> <tr><td></td><td></td><td>69</td><td></td><td></td><td></td><td></td><td></td><td>63</td><td></td><td></td><td></td><td></td><td></td><td>58</td><td></td><td>56</td><td></td><td>54</td><td></td></tr> <tr><td>52</td><td>51</td><td>49</td><td></td><td></td><td></td><td></td><td>44</td><td>43</td><td>42</td><td>41</td><td></td><td></td><td></td><td></td><td></td><td>36</td><td>35</td><td>34</td><td>33</td></tr> <tr><td></td><td></td><td></td><td>32</td><td></td><td></td><td></td><td></td><td>28</td><td></td><td>26</td><td></td><td></td><td></td><td></td><td></td><td></td><td>19</td><td>18</td><td></td></tr> <tr><td>73</td><td></td><td></td><td></td><td>16</td><td></td><td></td><td></td><td>12</td><td></td><td>10</td><td></td><td></td><td></td><td></td><td></td><td></td><td>3</td><td></td><td></td></tr> </table>			69						63						58		56		54		52	51	49					44	43	42	41						36	35	34	33				32					28		26							19	18		73				16				12		10							3		
		69						63						58		56		54																																																																					
52	51	49					44	43	42	41						36	35	34	33																																																																				
			32					28		26							19	18																																																																					
73				16				12		10							3																																																																						
AVAILABLE	NOT APPLICABLE	34566-2243	G	0	H	ST GRAY	<table border="1"> <tr><td></td><td>79</td><td>78</td><td>77</td><td>76</td><td>75</td><td>74</td><td>73</td><td>72</td><td>71</td><td>70</td><td>69</td><td>68</td><td></td><td>66</td><td>65</td><td>64</td><td>63</td><td></td><td>61</td></tr> <tr><td>60</td><td>59</td><td>58</td><td>57</td><td>56</td><td></td><td></td><td>53</td><td>52</td><td></td><td>50</td><td></td><td></td><td></td><td></td><td></td><td>44</td><td>43</td><td></td><td>41</td></tr> <tr><td>40</td><td>39</td><td>38</td><td>37</td><td></td><td>35</td><td>34</td><td>33</td><td>32</td><td></td><td>30</td><td>29</td><td></td><td>27</td><td>26</td><td></td><td>24</td><td>23</td><td></td><td>21</td></tr> <tr><td>20</td><td>19</td><td>18</td><td>17</td><td></td><td>16</td><td></td><td>14</td><td>13</td><td>12</td><td>11</td><td>10</td><td>9</td><td>8</td><td></td><td>6</td><td>5</td><td></td><td>3</td><td>2</td></tr> </table>		79	78	77	76	75	74	73	72	71	70	69	68		66	65	64	63		61	60	59	58	57	56			53	52		50						44	43		41	40	39	38	37		35	34	33	32		30	29		27	26		24	23		21	20	19	18	17		16		14	13	12	11	10	9	8		6	5		3	2
	79	78	77	76	75	74	73	72	71	70	69	68		66	65	64	63		61																																																																				
60	59	58	57	56			53	52		50						44	43		41																																																																				
40	39	38	37		35	34	33	32		30	29		27	26		24	23		21																																																																				
20	19	18	17		16		14	13	12	11	10	9	8		6	5		3	2																																																																				
AVAILABLE	NOT APPLICABLE	34566-2253	G	0	A	BLACK	<table border="1"> <tr><td>72</td><td>71</td><td>70</td><td>69</td><td>68</td><td></td><td>66</td><td>65</td><td>64</td><td>63</td><td></td><td>61</td><td></td><td>59</td><td>58</td><td></td><td>56</td><td></td><td>54</td><td>53</td></tr> <tr><td>52</td><td></td><td>50</td><td>49</td><td>47</td><td></td><td></td><td></td><td></td><td>42</td><td>41</td><td></td><td></td><td>38</td><td>37</td><td>36</td><td></td><td>34</td><td>33</td><td></td></tr> <tr><td></td><td></td><td></td><td>32</td><td>31</td><td>30</td><td></td><td>29</td><td>28</td><td>27</td><td>26</td><td></td><td>24</td><td>23</td><td>22</td><td>21</td><td>20</td><td>19</td><td>18</td><td>17</td></tr> <tr><td>73</td><td></td><td></td><td></td><td></td><td>16</td><td></td><td></td><td>13</td><td>12</td><td>11</td><td>10</td><td>9</td><td>8</td><td></td><td></td><td></td><td></td><td></td><td>1</td></tr> </table>	72	71	70	69	68		66	65	64	63		61		59	58		56		54	53	52		50	49	47					42	41			38	37	36		34	33					32	31	30		29	28	27	26		24	23	22	21	20	19	18	17	73					16			13	12	11	10	9	8						1
72	71	70	69	68		66	65	64	63		61		59	58		56		54	53																																																																				
52		50	49	47					42	41			38	37	36		34	33																																																																					
			32	31	30		29	28	27	26		24	23	22	21	20	19	18	17																																																																				
73					16			13	12	11	10	9	8						1																																																																				
AVAILABLE	NOT APPLICABLE	34566-2263	G	0	A	BLACK	<table border="1"> <tr><td></td><td></td><td>69</td><td></td><td></td><td></td><td></td><td></td><td>63</td><td></td><td></td><td></td><td></td><td></td><td>58</td><td></td><td>56</td><td>55</td><td>54</td><td>53</td></tr> <tr><td>52</td><td>51</td><td>50</td><td>49</td><td></td><td></td><td></td><td>44</td><td>43</td><td>42</td><td>41</td><td></td><td></td><td></td><td></td><td></td><td>36</td><td>35</td><td>34</td><td>33</td></tr> <tr><td></td><td></td><td></td><td>32</td><td></td><td></td><td></td><td></td><td>28</td><td></td><td>26</td><td></td><td></td><td></td><td></td><td></td><td></td><td>19</td><td>18</td><td></td></tr> <tr><td>73</td><td></td><td></td><td></td><td>16</td><td></td><td>14</td><td></td><td>12</td><td></td><td>10</td><td></td><td></td><td></td><td></td><td></td><td></td><td>3</td><td></td><td></td></tr> </table>			69						63						58		56	55	54	53	52	51	50	49				44	43	42	41						36	35	34	33				32					28		26							19	18		73				16		14		12		10							3		
		69						63						58		56	55	54	53																																																																				
52	51	50	49				44	43	42	41						36	35	34	33																																																																				
			32					28		26							19	18																																																																					
73				16		14		12		10							3																																																																						
AVAILABLE	NOT APPLICABLE	34566-2273	G	0	A	BLACK	<table border="1"> <tr><td></td><td></td><td>69</td><td></td><td></td><td></td><td></td><td></td><td>63</td><td>62</td><td>61</td><td></td><td></td><td></td><td>58</td><td>57</td><td>56</td><td>55</td><td>54</td><td>53</td></tr> <tr><td>52</td><td>51</td><td>50</td><td>49</td><td></td><td></td><td></td><td>44</td><td>43</td><td>42</td><td>41</td><td></td><td></td><td></td><td></td><td>37</td><td>36</td><td>35</td><td>34</td><td>33</td></tr> <tr><td></td><td></td><td></td><td>32</td><td></td><td></td><td></td><td></td><td>29</td><td>28</td><td>27</td><td>26</td><td></td><td></td><td></td><td></td><td></td><td>19</td><td>18</td><td></td></tr> <tr><td>73</td><td></td><td></td><td></td><td>16</td><td></td><td>14</td><td>13</td><td>12</td><td>11</td><td>10</td><td></td><td></td><td></td><td></td><td></td><td></td><td>3</td><td></td><td></td></tr> </table>			69						63	62	61				58	57	56	55	54	53	52	51	50	49				44	43	42	41					37	36	35	34	33				32					29	28	27	26						19	18		73				16		14	13	12	11	10							3		
		69						63	62	61				58	57	56	55	54	53																																																																				
52	51	50	49				44	43	42	41					37	36	35	34	33																																																																				
			32					29	28	27	26						19	18																																																																					
73				16		14	13	12	11	10							3																																																																						
AVAILABLE	NOT APPLICABLE	34566-2283	G	0	B	ST. GRAY	<table border="1"> <tr><td></td><td></td><td></td><td>68</td><td>67</td><td>66</td><td>65</td><td>64</td><td>63</td><td></td><td></td><td></td><td></td><td></td><td></td><td></td><td></td><td>55</td><td></td><td></td></tr> <tr><td></td><td></td><td>49</td><td>48</td><td>46</td><td>45</td><td>44</td><td>43</td><td></td><td></td><td></td><td></td><td></td><td></td><td></td><td></td><td></td><td></td><td></td><td></td></tr> <tr><td></td><td></td><td></td><td>32</td><td></td><td>30</td><td>29</td><td>28</td><td>27</td><td></td><td></td><td></td><td></td><td></td><td></td><td></td><td></td><td></td><td></td><td>17</td></tr> <tr><td>73</td><td></td><td></td><td></td><td>16</td><td></td><td></td><td></td><td></td><td>10</td><td></td><td></td><td></td><td></td><td></td><td></td><td></td><td></td><td></td><td></td></tr> </table>				68	67	66	65	64	63									55					49	48	46	45	44	43																32		30	29	28	27											17	73				16					10										
			68	67	66	65	64	63									55																																																																						
		49	48	46	45	44	43																																																																																
			32		30	29	28	27											17																																																																				
73				16					10																																																																														

ENTER DESCRIPTION ELEC NO: UAU2013-0662 DRAWN BY: DRWNTYE CHKD: APPR:WOSHY 2012/11/21 2012/11/21 F86	QUALITY SYMBOLS	GENERAL TOLERANCES (UNLESS SPECIFIED)	DIMENSION STYLE	SCALE	DESIGN UNITS	THIRD ANGLE PROJECTION	
	∇=0 ∇=0 ∇=0	4 PLACES ± --- + --- 3 PLACES ± --- + --- 2 PLACES ± --- + --- 1 PLACE ± --- + --- 0 PLACE ± --- + ---	mm INCH ± --- ± --- ± --- ± --- ± --- ± --- ± --- ± --- ± --- ± ---	MM ONLY DRAWN BY: SKRAJENDRANA DATE: 2011/02/14 CHECKED BY: MVANSLAMBROU DATE: 2011/02/14 APPROVED BY:	METRIC	METRIC	TITLE: MX123 66/73/80CKT HRNS CONN ASSY molex
	ANGULAR ± --- ° DRAFT WHERE APPLICABLE MUST REMAIN WITHIN DIMENSIONS	MATERIAL NO. SEE BOM TABLE	DOCUMENT NO. SD-34566-001	SHEET NO. 27 OF 59			
	THIS DRAWING CONTAINS INFORMATION THAT IS PROPRIETARY TO MOLEX INCORPORATED AND SHOULD NOT BE USED WITHOUT WRITTEN PERMISSION						

STATUS	GM PART #	MATERIAL #	PART/MATERIAL REVISION	WIRE DRESS OPTION	KEY OPTION	COLOR (TPA)	NUMBERS INDICATE CAVITIES OPEN FOR CIRCUITS																																																																
AVAILABLE	NOT APPLICABLE	34566-2293	G	0	C	BLUE	<table border="1"> <tr><td>72</td><td>70</td><td>68</td><td>66</td><td>63</td><td>59</td><td>57</td><td>53</td></tr> <tr><td>52</td><td>51</td><td>48</td><td>47</td><td>46</td><td>44</td><td>42</td><td>40</td><td>39</td><td>34</td><td>33</td></tr> <tr><td colspan="2">73</td><td>30</td><td>26</td><td>25</td><td>22</td><td>21</td><td></td><td></td><td></td><td></td></tr> <tr><td colspan="2"></td><td>15</td><td>14</td><td>10</td><td>9</td><td>6</td><td></td><td></td><td></td><td></td></tr> </table>	72	70	68	66	63	59	57	53	52	51	48	47	46	44	42	40	39	34	33	73		30	26	25	22	21							15	14	10	9	6																											
72	70	68	66	63	59	57	53																																																																
52	51	48	47	46	44	42	40	39	34	33																																																													
73		30	26	25	22	21																																																																	
		15	14	10	9	6																																																																	
AVAILABLE	NOT APPLICABLE	34566-2313	G	0	C	BLUE	<table border="1"> <tr><td>72</td><td>70</td><td>66</td><td>63</td><td>59</td><td>57</td><td>53</td></tr> <tr><td>52</td><td>51</td><td>46</td><td>44</td><td>42</td><td>40</td><td>39</td><td>34</td><td>33</td></tr> <tr><td colspan="2">73</td><td>30</td><td>26</td><td>25</td><td>22</td><td>21</td><td></td><td></td><td></td></tr> <tr><td colspan="2"></td><td>15</td><td>14</td><td>10</td><td>9</td><td>6</td><td></td><td></td><td></td></tr> </table>	72	70	66	63	59	57	53	52	51	46	44	42	40	39	34	33	73		30	26	25	22	21						15	14	10	9	6																															
72	70	66	63	59	57	53																																																																	
52	51	46	44	42	40	39	34	33																																																															
73		30	26	25	22	21																																																																	
		15	14	10	9	6																																																																	
AVAILABLE	NOT APPLICABLE	34566-2323	G	0	C	BLUE	<table border="1"> <tr><td>72</td><td>70</td><td>68</td><td>66</td><td>63</td><td>59</td><td>57</td><td>53</td></tr> <tr><td>52</td><td>51</td><td>48</td><td>47</td><td>46</td><td>44</td><td>42</td><td>40</td><td>39</td><td>34</td><td>33</td></tr> <tr><td colspan="2">73</td><td>30</td><td>26</td><td>25</td><td>22</td><td>21</td><td>20</td><td></td><td></td><td></td></tr> <tr><td colspan="2"></td><td>15</td><td>14</td><td>10</td><td>9</td><td>6</td><td>5</td><td>4</td><td></td><td></td></tr> </table>	72	70	68	66	63	59	57	53	52	51	48	47	46	44	42	40	39	34	33	73		30	26	25	22	21	20						15	14	10	9	6	5	4																									
72	70	68	66	63	59	57	53																																																																
52	51	48	47	46	44	42	40	39	34	33																																																													
73		30	26	25	22	21	20																																																																
		15	14	10	9	6	5	4																																																															
AVAILABLE	NOT APPLICABLE	34566-2333	G	0	A	BLACK	<table border="1"> <tr><td>71</td><td>69</td><td>68</td><td>65</td><td>64</td><td>63</td><td>61</td><td>59</td><td>57</td><td>56</td><td>34</td><td>33</td></tr> <tr><td>52</td><td>50</td><td>49</td><td>47</td><td>30</td><td>29</td><td>28</td><td>27</td><td>24</td><td>23</td><td>22</td><td>20</td><td>19</td><td>18</td></tr> <tr><td colspan="2">73</td><td>32</td><td>31</td><td>30</td><td>29</td><td>28</td><td>27</td><td>24</td><td>23</td><td>22</td><td>20</td><td>19</td><td>18</td></tr> <tr><td colspan="2"></td><td>16</td><td>13</td><td>12</td><td>11</td><td>10</td><td>9</td><td></td><td></td><td></td><td></td><td></td><td>1</td></tr> </table>	71	69	68	65	64	63	61	59	57	56	34	33	52	50	49	47	30	29	28	27	24	23	22	20	19	18	73		32	31	30	29	28	27	24	23	22	20	19	18			16	13	12	11	10	9						1										
71	69	68	65	64	63	61	59	57	56	34	33																																																												
52	50	49	47	30	29	28	27	24	23	22	20	19	18																																																										
73		32	31	30	29	28	27	24	23	22	20	19	18																																																										
		16	13	12	11	10	9						1																																																										
AVAILABLE	NOT APPLICABLE	34566-2343	G	0	A	BLACK	<table border="1"> <tr><td>72</td><td>70</td><td>68</td><td>67</td><td>66</td><td>65</td><td>58</td><td>57</td><td>55</td><td></td><td></td><td></td></tr> <tr><td></td><td>49</td><td>47</td><td>44</td><td>43</td><td>42</td><td>41</td><td>39</td><td>37</td><td>35</td><td></td><td></td></tr> <tr><td colspan="2">73</td><td>32</td><td>30</td><td>27</td><td>25</td><td>24</td><td>21</td><td>20</td><td>19</td><td>18</td><td>17</td></tr> <tr><td colspan="2"></td><td>15</td><td>14</td><td>13</td><td>9</td><td>8</td><td>6</td><td>5</td><td>3</td><td>1</td><td></td></tr> </table>	72	70	68	67	66	65	58	57	55					49	47	44	43	42	41	39	37	35			73		32	30	27	25	24	21	20	19	18	17			15	14	13	9	8	6	5	3	1																	
72	70	68	67	66	65	58	57	55																																																															
	49	47	44	43	42	41	39	37	35																																																														
73		32	30	27	25	24	21	20	19	18	17																																																												
		15	14	13	9	8	6	5	3	1																																																													
AVAILABLE	NOT APPLICABLE	34566-2353	G	0	A	BLACK	<table border="1"> <tr><td>72</td><td>70</td><td>67</td><td>66</td><td>65</td><td>58</td><td>57</td><td>55</td><td></td><td></td><td></td><td></td></tr> <tr><td></td><td>49</td><td>47</td><td>44</td><td>43</td><td>42</td><td>41</td><td>39</td><td>37</td><td>35</td><td></td><td></td></tr> <tr><td colspan="2">73</td><td>32</td><td>30</td><td>27</td><td>25</td><td>24</td><td>21</td><td>20</td><td>19</td><td>18</td><td>17</td></tr> <tr><td colspan="2"></td><td>15</td><td>14</td><td>13</td><td>9</td><td>8</td><td>6</td><td>5</td><td>3</td><td>1</td><td></td></tr> </table>	72	70	67	66	65	58	57	55						49	47	44	43	42	41	39	37	35			73		32	30	27	25	24	21	20	19	18	17			15	14	13	9	8	6	5	3	1																	
72	70	67	66	65	58	57	55																																																																
	49	47	44	43	42	41	39	37	35																																																														
73		32	30	27	25	24	21	20	19	18	17																																																												
		15	14	13	9	8	6	5	3	1																																																													
AVAILABLE	NOT APPLICABLE	34566-2363	G	0	C	BLUE	<table border="1"> <tr><td>72</td><td>70</td><td>67</td><td>66</td><td>63</td><td>62</td><td>59</td><td>57</td><td>53</td></tr> <tr><td>52</td><td>51</td><td>46</td><td>44</td><td>42</td><td>40</td><td>39</td><td>38</td><td>34</td><td>33</td></tr> <tr><td colspan="2">73</td><td>32</td><td>30</td><td>27</td><td>26</td><td>25</td><td>22</td><td>21</td><td>20</td><td></td></tr> <tr><td colspan="2"></td><td>15</td><td>14</td><td>10</td><td>9</td><td>6</td><td>5</td><td>4</td><td></td><td></td></tr> </table>	72	70	67	66	63	62	59	57	53	52	51	46	44	42	40	39	38	34	33	73		32	30	27	26	25	22	21	20				15	14	10	9	6	5	4																									
72	70	67	66	63	62	59	57	53																																																															
52	51	46	44	42	40	39	38	34	33																																																														
73		32	30	27	26	25	22	21	20																																																														
		15	14	10	9	6	5	4																																																															
AVAILABLE	NOT APPLICABLE	34566-2373	G	0	B	ST GRAY	<table border="1"> <tr><td>68</td><td>67</td><td>66</td><td>65</td><td>64</td><td>61</td><td>60</td><td>59</td><td>58</td><td>57</td><td>55</td><td>54</td><td>53</td></tr> <tr><td>51</td><td>50</td><td>49</td><td>48</td><td>47</td><td>46</td><td>45</td><td>43</td><td>42</td><td>41</td><td>40</td><td>39</td><td>38</td><td>37</td><td>35</td><td>34</td><td>33</td></tr> <tr><td colspan="2">73</td><td>32</td><td>31</td><td>30</td><td>26</td><td>24</td><td>23</td><td>22</td><td>21</td><td>20</td><td></td><td></td><td></td><td></td><td></td><td></td></tr> <tr><td colspan="2"></td><td>16</td><td>15</td><td>14</td><td>13</td><td>10</td><td>9</td><td>8</td><td>7</td><td>6</td><td>5</td><td>4</td><td>3</td><td>2</td><td></td><td></td></tr> </table>	68	67	66	65	64	61	60	59	58	57	55	54	53	51	50	49	48	47	46	45	43	42	41	40	39	38	37	35	34	33	73		32	31	30	26	24	23	22	21	20									16	15	14	13	10	9	8	7	6	5	4	3	2		
68	67	66	65	64	61	60	59	58	57	55	54	53																																																											
51	50	49	48	47	46	45	43	42	41	40	39	38	37	35	34	33																																																							
73		32	31	30	26	24	23	22	21	20																																																													
		16	15	14	13	10	9	8	7	6	5	4	3	2																																																									
AVAILABLE	NOT APPLICABLE	34566-2383	G	0	B	ST GRAY	<table border="1"> <tr><td>65</td><td>59</td><td>57</td><td>55</td><td>53</td></tr> <tr><td>50</td><td>49</td><td>48</td><td>46</td><td>39</td><td>37</td><td>35</td><td>33</td></tr> <tr><td colspan="2">73</td><td>29</td><td>24</td><td>23</td><td>21</td><td></td><td></td></tr> <tr><td colspan="2"></td><td>15</td><td>7</td><td>6</td><td>5</td><td>4</td><td>3</td></tr> </table>	65	59	57	55	53	50	49	48	46	39	37	35	33	73		29	24	23	21					15	7	6	5	4	3																																			
65	59	57	55	53																																																																			
50	49	48	46	39	37	35	33																																																																
73		29	24	23	21																																																																		
		15	7	6	5	4	3																																																																

ENTER DESCRIPTION EC NO: UAU2013-0662 DRAWN BY: 2012/11/01 CHKD: 2012/11/21 APPR: VIOSHY REV: 186	QUALITY SYMBOLS	GENERAL TOLERANCES (UNLESS SPECIFIED)	DIMENSION STYLE	SCALE	DESIGN UNITS	THIRD ANGLE PROJECTION	
	$\nabla=0$ $\nabla=0$ $\nabla=0$	mm INCH 4 PLACES ± 3 PLACES ± 2 PLACES ± 1 PLACE ± 0 PLACE ±	MM ONLY	DRAWN BY: SKRAJENDRANA CHECKED BY: MVANSLAMBROU APPROVED BY:	DATE: 2011/02/14	DATE: 2011/02/14	DATE:
	ANGULAR ± DRAFT WHERE APPLICABLE MUST REMAIN WITHIN DIMENSIONS	SEE BOM TABLE	MATERIAL NO. SD-34566-001	DOCUMENT NO.	TITLE: MX123 66/73/80CKT HRNS CONN ASSY molex		SHEET NO. 28 OF 59
	THIS DRAWING CONTAINS INFORMATION THAT IS PROPRIETARY TO MOLEX INCORPORATED AND SHOULD NOT BE USED WITHOUT WRITTEN PERMISSION						

STATUS	GM PART #	MATERIAL #	PART/MATERIAL REVISION	WIRE DRESS OPTION	KEY OPTION	COLOR (TPA)	NUMBERS INDICATE CAVITIES OPEN FOR CIRCUITS																																																																																																																			
AVAILABLE	NOT APPLICABLE	34566-2483	G	0	A	BLACK	<table border="1"> <tr><td></td><td></td><td></td><td>69</td><td></td><td></td><td></td><td></td><td></td><td></td><td>63</td><td>62</td><td>61</td><td></td><td></td><td>58</td><td>57</td><td>56</td><td>55</td><td>54</td><td>53</td></tr> <tr><td>52</td><td>51</td><td>49</td><td></td><td></td><td></td><td></td><td></td><td></td><td>44</td><td>43</td><td>42</td><td>41</td><td></td><td></td><td></td><td>37</td><td>36</td><td>35</td><td>34</td><td>33</td></tr> <tr><td colspan="20">73</td></tr> <tr><td></td><td></td><td></td><td>32</td><td></td><td></td><td></td><td></td><td></td><td>29</td><td>28</td><td>27</td><td>26</td><td></td><td></td><td>23</td><td></td><td></td><td></td><td>19</td><td>18</td></tr> <tr><td></td><td></td><td></td><td>16</td><td></td><td></td><td></td><td></td><td></td><td>13</td><td>12</td><td>11</td><td>10</td><td></td><td></td><td>8</td><td></td><td></td><td></td><td>3</td><td></td></tr> </table>				69							63	62	61			58	57	56	55	54	53	52	51	49							44	43	42	41				37	36	35	34	33	73																							32						29	28	27	26			23				19	18				16						13	12	11	10			8				3												
			69							63	62	61			58	57	56	55	54	53																																																																																																						
52	51	49							44	43	42	41				37	36	35	34	33																																																																																																						
73																																																																																																																										
			32						29	28	27	26			23				19	18																																																																																																						
			16						13	12	11	10			8				3																																																																																																							
AVAILABLE	NOT APPLICABLE	34566-2493	G	0	B	ST GRY	<table border="1"> <tr><td>72</td><td>71</td><td>70</td><td></td><td></td><td>68</td><td>67</td><td>66</td><td></td><td></td><td></td><td></td><td>62</td><td>61</td><td>60</td><td>59</td><td>58</td><td>57</td><td>56</td><td>55</td><td>54</td><td>53</td></tr> <tr><td>52</td><td>51</td><td>50</td><td></td><td></td><td>48</td><td>47</td><td>46</td><td></td><td></td><td></td><td></td><td>42</td><td>41</td><td>40</td><td>39</td><td>38</td><td>37</td><td>36</td><td>35</td><td>34</td><td>33</td></tr> <tr><td colspan="20">73</td></tr> <tr><td></td><td></td><td></td><td>32</td><td></td><td>31</td><td>30</td><td>29</td><td>28</td><td>27</td><td>26</td><td>25</td><td>24</td><td></td><td></td><td></td><td></td><td></td><td></td><td></td><td>17</td></tr> <tr><td></td><td></td><td></td><td>16</td><td></td><td>15</td><td>14</td><td>13</td><td></td><td></td><td></td><td></td><td>10</td><td></td><td></td><td>8</td><td></td><td></td><td></td><td></td><td>2</td><td>1</td></tr> </table>	72	71	70			68	67	66					62	61	60	59	58	57	56	55	54	53	52	51	50			48	47	46					42	41	40	39	38	37	36	35	34	33	73																							32		31	30	29	28	27	26	25	24								17				16		15	14	13					10			8					2	1								
72	71	70			68	67	66					62	61	60	59	58	57	56	55	54	53																																																																																																					
52	51	50			48	47	46					42	41	40	39	38	37	36	35	34	33																																																																																																					
73																																																																																																																										
			32		31	30	29	28	27	26	25	24								17																																																																																																						
			16		15	14	13					10			8					2	1																																																																																																					
AVAILABLE	NOT APPLICABLE	34566-2513	G	0	C	BLUE	<table border="1"> <tr><td>72</td><td>71</td><td>70</td><td></td><td></td><td>68</td><td>67</td><td>66</td><td></td><td></td><td></td><td>63</td><td>62</td><td></td><td></td><td>59</td><td></td><td>57</td><td></td><td></td><td></td><td>53</td></tr> <tr><td>52</td><td>51</td><td></td><td></td><td></td><td>48</td><td>47</td><td>46</td><td></td><td></td><td></td><td>44</td><td>42</td><td></td><td></td><td>40</td><td>39</td><td></td><td></td><td></td><td></td><td>34</td><td>33</td></tr> <tr><td colspan="20">73</td></tr> <tr><td></td><td></td><td></td><td>32</td><td></td><td></td><td>30</td><td></td><td></td><td></td><td></td><td>27</td><td>26</td><td>25</td><td></td><td></td><td></td><td>22</td><td>21</td><td>20</td><td></td><td></td></tr> <tr><td></td><td></td><td></td><td></td><td></td><td>15</td><td>14</td><td></td><td></td><td></td><td></td><td>10</td><td>9</td><td></td><td></td><td></td><td></td><td>6</td><td>5</td><td>4</td><td></td><td></td></tr> </table>	72	71	70			68	67	66				63	62			59		57				53	52	51				48	47	46				44	42			40	39					34	33	73																							32			30					27	26	25				22	21	20								15	14					10	9					6	5	4								
72	71	70			68	67	66				63	62			59		57				53																																																																																																					
52	51				48	47	46				44	42			40	39					34	33																																																																																																				
73																																																																																																																										
			32			30					27	26	25				22	21	20																																																																																																							
					15	14					10	9					6	5	4																																																																																																							
AVAILABLE	NOT APPLICABLE	34566-2523	G	0	A	BLACK	<table border="1"> <tr><td>72</td><td>71</td><td>70</td><td>69</td><td>68</td><td>67</td><td>66</td><td></td><td></td><td>65</td><td>64</td><td>63</td><td>62</td><td></td><td></td><td>60</td><td>59</td><td></td><td></td><td></td><td>55</td><td>54</td><td>53</td></tr> <tr><td>52</td><td></td><td></td><td>49</td><td>48</td><td></td><td></td><td></td><td></td><td>45</td><td>44</td><td>43</td><td>42</td><td></td><td></td><td>41</td><td>40</td><td>39</td><td></td><td></td><td></td><td>35</td><td>34</td><td>33</td></tr> <tr><td colspan="20">73</td></tr> <tr><td></td><td></td><td></td><td>32</td><td></td><td></td><td></td><td></td><td></td><td>29</td><td>28</td><td>27</td><td>26</td><td>25</td><td>24</td><td>23</td><td></td><td></td><td></td><td></td><td></td><td>19</td><td>18</td><td>17</td></tr> <tr><td></td><td></td><td></td><td>16</td><td></td><td></td><td></td><td></td><td></td><td>13</td><td>12</td><td>11</td><td></td><td></td><td></td><td>9</td><td>8</td><td>7</td><td>6</td><td>5</td><td>4</td><td>3</td><td>2</td><td>1</td></tr> </table>	72	71	70	69	68	67	66			65	64	63	62			60	59				55	54	53	52			49	48					45	44	43	42			41	40	39				35	34	33	73																							32						29	28	27	26	25	24	23						19	18	17				16						13	12	11				9	8	7	6	5	4	3	2	1
72	71	70	69	68	67	66			65	64	63	62			60	59				55	54	53																																																																																																				
52			49	48					45	44	43	42			41	40	39				35	34	33																																																																																																			
73																																																																																																																										
			32						29	28	27	26	25	24	23						19	18	17																																																																																																			
			16						13	12	11				9	8	7	6	5	4	3	2	1																																																																																																			
AVAILABLE	NOT APPLICABLE	34566-2533	G	0	B	ST GRY	<table border="1"> <tr><td></td><td></td><td></td><td></td><td></td><td>67</td><td>66</td><td>65</td><td></td><td></td><td></td><td></td><td></td><td></td><td></td><td>59</td><td>58</td><td>57</td><td>56</td><td>55</td><td></td><td>53</td></tr> <tr><td></td><td></td><td>50</td><td>49</td><td>48</td><td></td><td>46</td><td>45</td><td>43</td><td></td><td></td><td></td><td></td><td></td><td></td><td>39</td><td>38</td><td>37</td><td>36</td><td>35</td><td>34</td><td>33</td></tr> <tr><td colspan="20">73</td></tr> <tr><td></td><td></td><td></td><td></td><td></td><td></td><td></td><td></td><td>29</td><td></td><td>27</td><td></td><td></td><td></td><td></td><td>23</td><td>22</td><td>21</td><td></td><td></td><td></td><td>18</td></tr> <tr><td></td><td></td><td></td><td></td><td></td><td></td><td></td><td></td><td>16</td><td></td><td>15</td><td>14</td><td>13</td><td></td><td></td><td></td><td>8</td><td>7</td><td>6</td><td>5</td><td>4</td><td>3</td><td></td></tr> </table>						67	66	65								59	58	57	56	55		53			50	49	48		46	45	43							39	38	37	36	35	34	33	73																												29		27					23	22	21				18									16		15	14	13				8	7	6	5	4	3							
					67	66	65								59	58	57	56	55		53																																																																																																					
		50	49	48		46	45	43							39	38	37	36	35	34	33																																																																																																					
73																																																																																																																										
								29		27					23	22	21				18																																																																																																					
								16		15	14	13				8	7	6	5	4	3																																																																																																					
AVAILABLE	NOT APPLICABLE	34566-2543	G	0	C	BLUE	<table border="1"> <tr><td>72</td><td>71</td><td>70</td><td></td><td></td><td></td><td></td><td>66</td><td></td><td></td><td></td><td></td><td>63</td><td></td><td></td><td></td><td>59</td><td></td><td>57</td><td></td><td></td><td></td><td>53</td></tr> <tr><td>52</td><td>51</td><td></td><td></td><td></td><td></td><td></td><td>46</td><td></td><td></td><td></td><td></td><td>44</td><td></td><td></td><td>42</td><td></td><td>40</td><td>39</td><td></td><td></td><td></td><td>34</td><td>33</td></tr> <tr><td colspan="20">73</td></tr> <tr><td></td><td></td><td></td><td></td><td></td><td></td><td></td><td>32</td><td></td><td></td><td></td><td></td><td>27</td><td>26</td><td>25</td><td></td><td></td><td></td><td>22</td><td>21</td><td></td><td></td><td></td></tr> <tr><td></td><td></td><td></td><td></td><td></td><td></td><td></td><td></td><td></td><td></td><td></td><td></td><td>10</td><td>9</td><td></td><td></td><td></td><td></td><td>6</td><td>5</td><td>4</td><td></td><td></td></tr> </table>	72	71	70					66					63				59		57				53	52	51						46					44			42		40	39				34	33	73																											32					27	26	25				22	21																10	9					6	5	4				
72	71	70					66					63				59		57				53																																																																																																				
52	51						46					44			42		40	39				34	33																																																																																																			
73																																																																																																																										
							32					27	26	25				22	21																																																																																																							
												10	9					6	5	4																																																																																																						
AVAILABLE	NOT APPLICABLE	34566-2553	G	9	B	ST GRY	<table border="1"> <tr><td>72</td><td>71</td><td>70</td><td></td><td></td><td>68</td><td>67</td><td>66</td><td></td><td></td><td></td><td></td><td>62</td><td>61</td><td>60</td><td>59</td><td>58</td><td>57</td><td>56</td><td>55</td><td>54</td><td>53</td></tr> <tr><td>52</td><td>51</td><td>50</td><td></td><td></td><td>48</td><td>47</td><td>46</td><td></td><td></td><td></td><td></td><td>42</td><td>41</td><td>40</td><td>39</td><td>38</td><td>37</td><td>36</td><td>35</td><td>34</td><td>33</td></tr> <tr><td colspan="20">73</td></tr> <tr><td></td><td></td><td></td><td></td><td></td><td>32</td><td>31</td><td>30</td><td>29</td><td>28</td><td>27</td><td>26</td><td>25</td><td>24</td><td>23</td><td></td><td></td><td></td><td></td><td></td><td></td><td></td></tr> <tr><td></td><td></td><td></td><td></td><td></td><td>16</td><td>15</td><td>14</td><td>13</td><td></td><td></td><td></td><td>10</td><td>9</td><td>8</td><td></td><td></td><td></td><td></td><td></td><td></td><td></td><td></td></tr> </table>	72	71	70			68	67	66					62	61	60	59	58	57	56	55	54	53	52	51	50			48	47	46					42	41	40	39	38	37	36	35	34	33	73																									32	31	30	29	28	27	26	25	24	23													16	15	14	13				10	9	8														
72	71	70			68	67	66					62	61	60	59	58	57	56	55	54	53																																																																																																					
52	51	50			48	47	46					42	41	40	39	38	37	36	35	34	33																																																																																																					
73																																																																																																																										
					32	31	30	29	28	27	26	25	24	23																																																																																																												
					16	15	14	13				10	9	8																																																																																																												
AVAILABLE	NOT APPLICABLE	34566-2563	G	9	A	BLACK	<table border="1"> <tr><td></td><td></td><td></td><td>69</td><td></td><td></td><td></td><td></td><td></td><td></td><td></td><td></td><td>63</td><td>62</td><td>61</td><td></td><td></td><td>58</td><td>57</td><td>56</td><td>55</td><td>54</td><td>53</td></tr> <tr><td>52</td><td>51</td><td>50</td><td>49</td><td></td><td></td><td></td><td></td><td></td><td></td><td></td><td></td><td>44</td><td>43</td><td>42</td><td>41</td><td></td><td></td><td>37</td><td>36</td><td>35</td><td>34</td><td>33</td></tr> <tr><td colspan="20">73</td></tr> <tr><td></td><td></td><td></td><td></td><td></td><td></td><td></td><td></td><td></td><td></td><td></td><td></td><td>29</td><td>28</td><td>27</td><td>26</td><td></td><td></td><td></td><td></td><td></td><td>19</td><td>18</td></tr> <tr><td></td><td></td><td></td><td></td><td></td><td></td><td></td><td></td><td></td><td></td><td></td><td></td><td>16</td><td></td><td>14</td><td>13</td><td>12</td><td>11</td><td>10</td><td></td><td></td><td></td><td>3</td></tr> </table>				69									63	62	61			58	57	56	55	54	53	52	51	50	49									44	43	42	41			37	36	35	34	33	73																																29	28	27	26						19	18													16		14	13	12	11	10				3			
			69									63	62	61			58	57	56	55	54	53																																																																																																				
52	51	50	49									44	43	42	41			37	36	35	34	33																																																																																																				
73																																																																																																																										
												29	28	27	26						19	18																																																																																																				
												16		14	13	12	11	10				3																																																																																																				
AVAILABLE	NOT APPLICABLE	34566-2573	G	9	C	BLUE	<table border="1"> <tr><td>72</td><td>71</td><td>70</td><td></td><td></td><td></td><td></td><td>67</td><td>66</td><td></td><td></td><td></td><td>63</td><td>62</td><td></td><td></td><td>59</td><td></td><td>57</td><td></td><td></td><td></td><td>53</td></tr> <tr><td>52</td><td>51</td><td></td><td></td><td></td><td></td><td></td><td>46</td><td>44</td><td></td><td></td><td></td><td>42</td><td></td><td></td><td>40</td><td>39</td><td></td><td></td><td></td><td></td><td></td><td>34</td><td>33</td></tr> <tr><td colspan="20">73</td></tr> <tr><td></td><td></td><td></td><td></td><td></td><td></td><td></td><td></td><td>30</td><td></td><td></td><td></td><td>26</td><td>25</td><td></td><td></td><td></td><td></td><td>22</td><td>21</td><td>20</td><td></td><td></td></tr> <tr><td></td><td></td><td></td><td></td><td></td><td></td><td></td><td></td><td></td><td></td><td></td><td></td><td>10</td><td>9</td><td></td><td></td><td></td><td></td><td>6</td><td>5</td><td>4</td><td></td><td></td></tr> </table>	72	71	70					67	66				63	62			59		57				53	52	51						46	44				42			40	39						34	33	73																												30				26	25					22	21	20															10	9					6	5	4				
72	71	70					67	66				63	62			59		57				53																																																																																																				
52	51						46	44				42			40	39						34	33																																																																																																			
73																																																																																																																										
								30				26	25					22	21	20																																																																																																						
												10	9					6	5	4																																																																																																						

ENTER DESCRIPTION ELC NO: UAU2013-0662 DRAWN BY: 2012/11/01 CHKD: APPR: IKOSHY 2012/11/21 REV: 186	QUALITY SYMBOLS	GENERAL TOLERANCES (UNLESS SPECIFIED)	DIMENSION STYLE	SCALE	DESIGN UNITS	THIRD ANGLE PROJECTION
	▽=0	4 PLACES ±--- INCH	MM ONLY		METRIC	
	▽=0	3 PLACES ±--- INCH	DRAWN BY: SKRA JENDRANA 2011/02/14	DATE		TITLE
	▽=0	2 PLACES ±--- INCH	CHECKED BY: MYANSLAMBROU 2011/02/14	DATE		
	1 PLACE ±--- INCH	APPROVED BY:	DATE			
	0 PLACE ±--- INCH					
	ANGULAR ±---°	DRAFT WHERE APPLICABLE MUST REMAIN WITHIN DIMENSIONS	MATERIAL NO.	DOCUMENT NO.		
			SEE BOM TABLE	SD-34566-001		
			THIS DRAWING CONTAINS INFORMATION THAT IS PROPRIETARY TO MOLEX INCORPORATED AND SHOULD NOT BE USED WITHOUT WRITTEN PERMISSION			

MX123
66/73/80CKT
HRNS CONN ASSY

molex

SHEET NO.
30 OF 59

STATUS	GM PART #	MATERIAL #	PART/MATERIAL REVISION	WIRE DRESS OPTION	KEY OPTION	COLOR (TPA)	NUMBERS INDICATE CAVITIES OPEN FOR CIRCUITS																																																																										
AVAILABLE	NOT APPLICABLE	34566-2583	G	0	A	BLACK	<table border="1"> <tr><td></td><td></td><td>69</td><td></td><td></td><td></td><td>63</td><td></td><td></td><td>58</td><td>56</td><td>55</td><td>54</td><td>53</td></tr> <tr><td>52</td><td>51</td><td>50</td><td>49</td><td></td><td></td><td>44</td><td>43</td><td>42</td><td>41</td><td>39</td><td></td><td>36</td><td>35</td><td>34</td><td>33</td></tr> <tr><td></td><td></td><td>73</td><td></td><td>32</td><td></td><td>28</td><td>26</td><td></td><td></td><td></td><td></td><td>19</td><td>18</td><td></td><td></td></tr> <tr><td></td><td></td><td></td><td></td><td>16</td><td></td><td>14</td><td>12</td><td>10</td><td></td><td></td><td></td><td>3</td><td></td><td></td><td></td></tr> </table>			69				63			58	56	55	54	53	52	51	50	49			44	43	42	41	39		36	35	34	33			73		32		28	26					19	18							16		14	12	10				3															
		69				63			58	56	55	54	53																																																																				
52	51	50	49			44	43	42	41	39		36	35	34	33																																																																		
		73		32		28	26					19	18																																																																				
				16		14	12	10				3																																																																					
AVAILABLE	NOT APPLICABLE	34566-2593	G	0	C	BLUE	<table border="1"> <tr><td>72</td><td>70</td><td></td><td></td><td>66</td><td></td><td>63</td><td>62</td><td></td><td>59</td><td>57</td><td></td><td></td><td></td><td>53</td><td></td></tr> <tr><td>52</td><td>51</td><td></td><td></td><td>46</td><td>44</td><td>42</td><td>40</td><td>39</td><td></td><td></td><td></td><td></td><td></td><td>34</td><td>33</td></tr> <tr><td></td><td></td><td>73</td><td></td><td>32</td><td>30</td><td></td><td>27</td><td>26</td><td>25</td><td></td><td>22</td><td>21</td><td></td><td></td><td></td></tr> <tr><td></td><td></td><td></td><td></td><td>15</td><td>14</td><td></td><td></td><td>10</td><td>9</td><td></td><td>6</td><td></td><td></td><td></td><td></td></tr> </table>	72	70			66		63	62		59	57				53		52	51			46	44	42	40	39						34	33			73		32	30		27	26	25		22	21								15	14			10	9		6														
72	70			66		63	62		59	57				53																																																																			
52	51			46	44	42	40	39						34	33																																																																		
		73		32	30		27	26	25		22	21																																																																					
				15	14			10	9		6																																																																						
AVAILABLE	NOT APPLICABLE	34566-2613	G	9	C	BLUE	<table border="1"> <tr><td>72</td><td>70</td><td></td><td>67</td><td>66</td><td></td><td>63</td><td>62</td><td></td><td>59</td><td>57</td><td></td><td></td><td></td><td>53</td><td></td></tr> <tr><td>52</td><td>51</td><td></td><td></td><td>46</td><td>44</td><td>42</td><td>40</td><td>39</td><td></td><td></td><td></td><td></td><td></td><td>34</td><td>33</td></tr> <tr><td></td><td></td><td>73</td><td></td><td></td><td>30</td><td></td><td>27</td><td>26</td><td>25</td><td></td><td>22</td><td>21</td><td>20</td><td></td><td></td></tr> <tr><td></td><td></td><td></td><td></td><td>15</td><td>14</td><td></td><td></td><td>10</td><td>9</td><td></td><td>6</td><td>5</td><td>4</td><td></td><td></td></tr> </table>	72	70		67	66		63	62		59	57				53		52	51			46	44	42	40	39						34	33			73			30		27	26	25		22	21	20							15	14			10	9		6	5	4												
72	70		67	66		63	62		59	57				53																																																																			
52	51			46	44	42	40	39						34	33																																																																		
		73			30		27	26	25		22	21	20																																																																				
				15	14			10	9		6	5	4																																																																				
AVAILABLE	NOT APPLICABLE	34566-2623	G	0	A	BLACK	<table border="1"> <tr><td>71</td><td>69</td><td>68</td><td>67</td><td></td><td>65</td><td>64</td><td>63</td><td></td><td>61</td><td>59</td><td></td><td>57</td><td>56</td><td></td><td></td></tr> <tr><td></td><td>50</td><td>49</td><td></td><td>47</td><td></td><td></td><td></td><td></td><td>41</td><td></td><td></td><td>38</td><td>37</td><td>36</td><td>34</td><td>33</td></tr> <tr><td></td><td></td><td>73</td><td></td><td>32</td><td>31</td><td>30</td><td>29</td><td>28</td><td>27</td><td></td><td>24</td><td>23</td><td></td><td>20</td><td>19</td><td>18</td></tr> <tr><td></td><td></td><td></td><td></td><td>16</td><td></td><td></td><td>13</td><td>12</td><td>11</td><td>10</td><td>9</td><td>7</td><td></td><td>4</td><td></td><td></td></tr> </table>	71	69	68	67		65	64	63		61	59		57	56				50	49		47					41			38	37	36	34	33			73		32	31	30	29	28	27		24	23		20	19	18					16			13	12	11	10	9	7		4									
71	69	68	67		65	64	63		61	59		57	56																																																																				
	50	49		47					41			38	37	36	34	33																																																																	
		73		32	31	30	29	28	27		24	23		20	19	18																																																																	
				16			13	12	11	10	9	7		4																																																																			
AVAILABLE	NOT APPLICABLE	34566-2633	G	0	A	BLACK	<table border="1"> <tr><td>71</td><td>69</td><td>68</td><td>67</td><td></td><td>65</td><td>64</td><td></td><td></td><td>61</td><td>59</td><td></td><td>57</td><td>56</td><td></td><td></td></tr> <tr><td></td><td>50</td><td>49</td><td></td><td>47</td><td></td><td></td><td></td><td></td><td>41</td><td></td><td></td><td>38</td><td>37</td><td>36</td><td></td><td>33</td></tr> <tr><td></td><td></td><td>73</td><td></td><td>32</td><td>31</td><td>30</td><td>29</td><td>28</td><td>27</td><td></td><td>24</td><td>23</td><td></td><td>20</td><td>19</td><td>18</td></tr> <tr><td></td><td></td><td></td><td></td><td>16</td><td></td><td></td><td></td><td></td><td>11</td><td>10</td><td>9</td><td>7</td><td></td><td>4</td><td></td><td></td></tr> </table>	71	69	68	67		65	64			61	59		57	56				50	49		47					41			38	37	36		33			73		32	31	30	29	28	27		24	23		20	19	18					16					11	10	9	7		4									
71	69	68	67		65	64			61	59		57	56																																																																				
	50	49		47					41			38	37	36		33																																																																	
		73		32	31	30	29	28	27		24	23		20	19	18																																																																	
				16					11	10	9	7		4																																																																			
AVAILABLE	NOT APPLICABLE	34566-2643	G	0	A	BLACK	<table border="1"> <tr><td>71</td><td>69</td><td>68</td><td>67</td><td></td><td>65</td><td>64</td><td>63</td><td></td><td>61</td><td>59</td><td></td><td>57</td><td>56</td><td></td><td></td></tr> <tr><td></td><td>50</td><td>49</td><td></td><td>47</td><td></td><td></td><td></td><td></td><td>41</td><td>39</td><td>38</td><td>37</td><td>36</td><td></td><td>34</td><td>33</td></tr> <tr><td></td><td></td><td>73</td><td></td><td>32</td><td>31</td><td>30</td><td>29</td><td>28</td><td>27</td><td></td><td>24</td><td>23</td><td>22</td><td>20</td><td>19</td><td>18</td></tr> <tr><td></td><td></td><td></td><td></td><td>16</td><td></td><td></td><td></td><td>13</td><td>12</td><td>11</td><td>10</td><td>9</td><td>7</td><td></td><td>4</td><td></td></tr> </table>	71	69	68	67		65	64	63		61	59		57	56				50	49		47					41	39	38	37	36		34	33			73		32	31	30	29	28	27		24	23	22	20	19	18					16				13	12	11	10	9	7		4								
71	69	68	67		65	64	63		61	59		57	56																																																																				
	50	49		47					41	39	38	37	36		34	33																																																																	
		73		32	31	30	29	28	27		24	23	22	20	19	18																																																																	
				16				13	12	11	10	9	7		4																																																																		
AVAILABLE	NOT APPLICABLE	34566-2653	G	0	A	BLACK	<table border="1"> <tr><td>71</td><td>69</td><td>68</td><td>67</td><td></td><td>65</td><td>64</td><td></td><td></td><td>61</td><td>59</td><td></td><td>57</td><td>56</td><td></td><td></td></tr> <tr><td></td><td>50</td><td>49</td><td></td><td>47</td><td></td><td></td><td></td><td></td><td>41</td><td>39</td><td>38</td><td>37</td><td>36</td><td></td><td>34</td><td>33</td></tr> <tr><td></td><td></td><td>73</td><td></td><td>32</td><td>31</td><td>30</td><td>29</td><td>28</td><td>27</td><td></td><td>24</td><td>23</td><td>22</td><td>20</td><td>19</td><td>18</td></tr> <tr><td></td><td></td><td></td><td></td><td>16</td><td></td><td></td><td></td><td></td><td>11</td><td>10</td><td>9</td><td>7</td><td></td><td>4</td><td></td><td></td></tr> </table>	71	69	68	67		65	64			61	59		57	56				50	49		47					41	39	38	37	36		34	33			73		32	31	30	29	28	27		24	23	22	20	19	18					16					11	10	9	7		4									
71	69	68	67		65	64			61	59		57	56																																																																				
	50	49		47					41	39	38	37	36		34	33																																																																	
		73		32	31	30	29	28	27		24	23	22	20	19	18																																																																	
				16					11	10	9	7		4																																																																			
AVAILABLE	NOT APPLICABLE	34566-2663	G	0	H	ST GRAY	<table border="1"> <tr><td>79</td><td>78</td><td>77</td><td>76</td><td>75</td><td>74</td><td>73</td><td>72</td><td>71</td><td>70</td><td>69</td><td>68</td><td></td><td>66</td><td>65</td><td>64</td><td>63</td><td>61</td></tr> <tr><td>60</td><td>59</td><td>58</td><td>57</td><td>56</td><td></td><td></td><td>53</td><td>52</td><td>50</td><td></td><td></td><td></td><td></td><td></td><td>44</td><td>43</td><td>41</td></tr> <tr><td>40</td><td>39</td><td>38</td><td>37</td><td></td><td>35</td><td>34</td><td></td><td>32</td><td>30</td><td>29</td><td></td><td>27</td><td>26</td><td></td><td></td><td></td><td>22</td><td>21</td></tr> <tr><td>20</td><td>19</td><td>18</td><td>17</td><td></td><td></td><td></td><td>13</td><td>12</td><td></td><td></td><td></td><td>8</td><td>6</td><td>5</td><td></td><td>3</td><td>2</td><td></td></tr> </table>	79	78	77	76	75	74	73	72	71	70	69	68		66	65	64	63	61	60	59	58	57	56			53	52	50						44	43	41	40	39	38	37		35	34		32	30	29		27	26				22	21	20	19	18	17				13	12				8	6	5		3	2	
79	78	77	76	75	74	73	72	71	70	69	68		66	65	64	63	61																																																																
60	59	58	57	56			53	52	50						44	43	41																																																																
40	39	38	37		35	34		32	30	29		27	26				22	21																																																															
20	19	18	17				13	12				8	6	5		3	2																																																																
AVAILABLE	NOT APPLICABLE	34566-2673	G	0	H	ST GRAY	<table border="1"> <tr><td>79</td><td>78</td><td>77</td><td>76</td><td>75</td><td>74</td><td>73</td><td>72</td><td>71</td><td>70</td><td>69</td><td>68</td><td></td><td>66</td><td>65</td><td>64</td><td>63</td><td>61</td></tr> <tr><td>60</td><td>59</td><td>58</td><td>57</td><td>56</td><td></td><td></td><td>53</td><td>52</td><td>50</td><td></td><td></td><td></td><td></td><td></td><td>44</td><td>43</td><td>41</td></tr> <tr><td>40</td><td>39</td><td>38</td><td>37</td><td></td><td>35</td><td>34</td><td></td><td>32</td><td>30</td><td>29</td><td></td><td>27</td><td>26</td><td></td><td></td><td></td><td>22</td><td>21</td></tr> <tr><td>20</td><td>19</td><td>18</td><td>17</td><td>16</td><td></td><td></td><td>13</td><td>12</td><td></td><td></td><td></td><td>8</td><td>6</td><td>5</td><td></td><td>3</td><td>2</td><td></td></tr> </table>	79	78	77	76	75	74	73	72	71	70	69	68		66	65	64	63	61	60	59	58	57	56			53	52	50						44	43	41	40	39	38	37		35	34		32	30	29		27	26				22	21	20	19	18	17	16			13	12				8	6	5		3	2	
79	78	77	76	75	74	73	72	71	70	69	68		66	65	64	63	61																																																																
60	59	58	57	56			53	52	50						44	43	41																																																																
40	39	38	37		35	34		32	30	29		27	26				22	21																																																															
20	19	18	17	16			13	12				8	6	5		3	2																																																																

ENTER DESCRIPTION IEC NO: UAU2013-0662 DRAWN BY: 2012/11/01 CHKD: 2012/11/21 APPR: IKOSHY F86	QUALITY SYMBOLS ∇=0 ∇=0 ∇=0	GENERAL TOLERANCES (UNLESS SPECIFIED) mm INCH 4 PLACES ±--- ±--- 3 PLACES ±--- ±--- 2 PLACES ±--- ±--- 1 PLACE ±--- ±--- 0 PLACE ±--- ±--- ANGULAR ±---° DRAFT WHERE APPLICABLE MUST REMAIN WITHIN DIMENSIONS	DIMENSION STYLE MM ONLY DRAWN BY: SKRAJENDRANA 2011/02/14 CHECKED BY: DATE MYANSLAMBROU 2011/02/14 APPROVED BY: DATE	SCALE METRIC	DESIGN UNITS METRIC	THIRD ANGLE PROJECTION
	TITLE MX123 66/73/80CKT HRNS CONN ASSY			MATERIAL NO. DOCUMENT NO. SD-34566-001		SHEET NO. 31 OF 59
	THIS DRAWING CONTAINS INFORMATION THAT IS PROPRIETARY TO MOLEX INCORPORATED AND SHOULD NOT BE USED WITHOUT WRITTEN PERMISSION					
	SIZE D					

STATUS	GM PART #	MATERIAL #	PART/MATERIAL REVISION	WIRE DRESS OPTION	KEY OPTION	COLOR (TPA)	NUMBERS INDICATE CAVITIES OPEN FOR CIRCUITS																																																																																		
AVAILABLE	NOT APPLICABLE	34566-2793	G	9	A	BLACK	<table border="1"> <tr><td></td><td></td><td></td><td></td><td>67</td><td>66</td><td></td><td></td><td></td><td></td><td></td><td></td><td></td><td></td><td></td><td></td><td></td><td></td><td></td><td></td><td></td></tr> <tr><td></td><td></td><td></td><td></td><td>48</td><td>47</td><td></td><td></td><td></td><td></td><td>41</td><td></td><td></td><td></td><td></td><td></td><td></td><td></td><td></td><td></td><td></td></tr> <tr><td></td><td></td><td>73</td><td></td><td>32</td><td>31</td><td>30</td><td>29</td><td></td><td>27</td><td></td><td>25</td><td></td><td></td><td>22</td><td>21</td><td></td><td>19</td><td>18</td><td>17</td></tr> <tr><td></td><td></td><td></td><td></td><td>16</td><td>15</td><td>14</td><td>13</td><td></td><td>11</td><td>10</td><td>9</td><td>8</td><td>7</td><td>6</td><td>5</td><td>4</td><td>3</td><td></td><td>1</td></tr> </table>					67	66																				48	47					41													73		32	31	30	29		27		25			22	21		19	18	17					16	15	14	13		11	10	9	8	7	6	5	4	3		1
				67	66																																																																																				
				48	47					41																																																																															
		73		32	31	30	29		27		25			22	21		19	18	17																																																																						
				16	15	14	13		11	10	9	8	7	6	5	4	3		1																																																																						
AVAILABLE	NOT APPLICABLE	34566-2813	G	9	B	ST GRY	<table border="1"> <tr><td>72</td><td>71</td><td>70</td><td>69</td><td>68</td><td>67</td><td>66</td><td>65</td><td>64</td><td></td><td>62</td><td>61</td><td>60</td><td>59</td><td>58</td><td>57</td><td>56</td><td>55</td><td>54</td><td></td></tr> <tr><td>52</td><td>51</td><td>50</td><td>49</td><td>48</td><td>46</td><td>44</td><td></td><td></td><td></td><td></td><td>40</td><td></td><td></td><td></td><td>37</td><td>36</td><td></td><td></td><td></td></tr> <tr><td></td><td></td><td>73</td><td></td><td>32</td><td>31</td><td>30</td><td>29</td><td>28</td><td>27</td><td></td><td>25</td><td>24</td><td></td><td></td><td>21</td><td>20</td><td></td><td>18</td><td></td></tr> <tr><td></td><td></td><td></td><td></td><td>16</td><td>14</td><td>13</td><td>12</td><td>11</td><td>10</td><td>9</td><td></td><td>7</td><td>6</td><td></td><td>4</td><td>3</td><td>2</td><td></td><td></td></tr> </table>	72	71	70	69	68	67	66	65	64		62	61	60	59	58	57	56	55	54		52	51	50	49	48	46	44					40				37	36						73		32	31	30	29	28	27		25	24			21	20		18						16	14	13	12	11	10	9		7	6		4	3	2				
72	71	70	69	68	67	66	65	64		62	61	60	59	58	57	56	55	54																																																																							
52	51	50	49	48	46	44					40				37	36																																																																									
		73		32	31	30	29	28	27		25	24			21	20		18																																																																							
				16	14	13	12	11	10	9		7	6		4	3	2																																																																								
AVAILABLE	NOT APPLICABLE	34566-2823	G	0	A	BLACK	<table border="1"> <tr><td></td><td></td><td></td><td></td><td>67</td><td>66</td><td></td><td></td><td></td><td></td><td></td><td></td><td></td><td></td><td></td><td></td><td></td><td></td><td></td><td></td><td></td></tr> <tr><td></td><td></td><td></td><td></td><td>47</td><td></td><td></td><td></td><td></td><td></td><td>41</td><td></td><td></td><td></td><td></td><td></td><td></td><td></td><td></td><td></td><td></td></tr> <tr><td></td><td></td><td>73</td><td></td><td>32</td><td>31</td><td>30</td><td>29</td><td></td><td>27</td><td></td><td>25</td><td></td><td></td><td>22</td><td>21</td><td></td><td>19</td><td>18</td><td>17</td></tr> <tr><td></td><td></td><td></td><td></td><td>16</td><td>15</td><td>14</td><td>13</td><td></td><td></td><td>10</td><td>9</td><td>8</td><td>7</td><td>6</td><td>5</td><td>4</td><td>3</td><td></td><td></td></tr> </table>					67	66																				47						41													73		32	31	30	29		27		25			22	21		19	18	17					16	15	14	13			10	9	8	7	6	5	4	3		
				67	66																																																																																				
				47						41																																																																															
		73		32	31	30	29		27		25			22	21		19	18	17																																																																						
				16	15	14	13			10	9	8	7	6	5	4	3																																																																								
AVAILABLE	NOT APPLICABLE	34566-2833	G	0	B	ST GRY	<table border="1"> <tr><td>72</td><td>71</td><td>70</td><td>69</td><td>68</td><td>67</td><td>66</td><td>65</td><td></td><td></td><td>61</td><td>60</td><td></td><td></td><td></td><td>57</td><td>56</td><td>55</td><td>54</td><td></td></tr> <tr><td>52</td><td>51</td><td>50</td><td>49</td><td>48</td><td>46</td><td>44</td><td></td><td></td><td></td><td></td><td>40</td><td></td><td></td><td></td><td>37</td><td>36</td><td></td><td></td><td></td></tr> <tr><td></td><td></td><td>73</td><td></td><td>32</td><td>31</td><td>30</td><td>29</td><td>28</td><td>27</td><td></td><td>24</td><td></td><td></td><td></td><td>21</td><td>20</td><td></td><td>19</td><td>18</td></tr> <tr><td></td><td></td><td></td><td></td><td>16</td><td>14</td><td>13</td><td>12</td><td>11</td><td>10</td><td>9</td><td></td><td>7</td><td>6</td><td></td><td>4</td><td>3</td><td>2</td><td></td><td></td></tr> </table>	72	71	70	69	68	67	66	65			61	60				57	56	55	54		52	51	50	49	48	46	44					40				37	36						73		32	31	30	29	28	27		24				21	20		19	18					16	14	13	12	11	10	9		7	6		4	3	2				
72	71	70	69	68	67	66	65			61	60				57	56	55	54																																																																							
52	51	50	49	48	46	44					40				37	36																																																																									
		73		32	31	30	29	28	27		24				21	20		19	18																																																																						
				16	14	13	12	11	10	9		7	6		4	3	2																																																																								
AVAILABLE	NOT APPLICABLE	34566-2843	G	0	A	BLACK	<table border="1"> <tr><td></td><td></td><td></td><td></td><td>67</td><td>66</td><td></td><td></td><td></td><td></td><td></td><td></td><td></td><td></td><td></td><td></td><td></td><td></td><td></td><td></td><td></td></tr> <tr><td></td><td></td><td></td><td></td><td>47</td><td></td><td></td><td></td><td></td><td></td><td>41</td><td></td><td></td><td></td><td></td><td></td><td></td><td></td><td></td><td></td><td></td></tr> <tr><td></td><td></td><td>73</td><td></td><td>32</td><td>31</td><td>30</td><td>29</td><td></td><td>27</td><td></td><td>25</td><td></td><td></td><td>22</td><td>21</td><td></td><td>19</td><td>18</td><td>17</td></tr> <tr><td></td><td></td><td></td><td></td><td>16</td><td>15</td><td>14</td><td>13</td><td></td><td></td><td>10</td><td>9</td><td>8</td><td>7</td><td>6</td><td>5</td><td>4</td><td>3</td><td></td><td>1</td></tr> </table>					67	66																				47						41													73		32	31	30	29		27		25			22	21		19	18	17					16	15	14	13			10	9	8	7	6	5	4	3		1
				67	66																																																																																				
				47						41																																																																															
		73		32	31	30	29		27		25			22	21		19	18	17																																																																						
				16	15	14	13			10	9	8	7	6	5	4	3		1																																																																						
AVAILABLE	NOT APPLICABLE	34566-2853	G	0	B	ST GRY	<table border="1"> <tr><td>72</td><td>71</td><td>70</td><td>69</td><td>68</td><td>67</td><td>66</td><td>65</td><td>64</td><td>63</td><td></td><td>61</td><td>60</td><td></td><td></td><td>57</td><td>56</td><td>55</td><td>54</td><td></td></tr> <tr><td>52</td><td>51</td><td>50</td><td>49</td><td>48</td><td>46</td><td>44</td><td></td><td></td><td></td><td></td><td>40</td><td></td><td></td><td></td><td>37</td><td>36</td><td></td><td></td><td></td></tr> <tr><td></td><td></td><td>73</td><td></td><td>32</td><td>31</td><td>30</td><td>29</td><td>28</td><td>27</td><td></td><td>24</td><td></td><td></td><td></td><td>21</td><td>20</td><td>19</td><td>18</td><td></td></tr> <tr><td></td><td></td><td></td><td></td><td>16</td><td>14</td><td>13</td><td>12</td><td>11</td><td>10</td><td>9</td><td></td><td>7</td><td>6</td><td></td><td>4</td><td>3</td><td>2</td><td></td><td></td></tr> </table>	72	71	70	69	68	67	66	65	64	63		61	60			57	56	55	54		52	51	50	49	48	46	44					40				37	36						73		32	31	30	29	28	27		24				21	20	19	18						16	14	13	12	11	10	9		7	6		4	3	2				
72	71	70	69	68	67	66	65	64	63		61	60			57	56	55	54																																																																							
52	51	50	49	48	46	44					40				37	36																																																																									
		73		32	31	30	29	28	27		24				21	20	19	18																																																																							
				16	14	13	12	11	10	9		7	6		4	3	2																																																																								
AVAILABLE	NOT APPLICABLE	34566-2863	G	0	A	BLACK	<table border="1"> <tr><td>72</td><td>71</td><td>70</td><td>69</td><td>68</td><td>67</td><td>66</td><td></td><td>64</td><td>63</td><td>62</td><td></td><td>60</td><td>59</td><td></td><td></td><td></td><td>55</td><td>54</td><td>53</td></tr> <tr><td>52</td><td></td><td></td><td>49</td><td>48</td><td>46</td><td>44</td><td>43</td><td>42</td><td></td><td></td><td>40</td><td>39</td><td></td><td></td><td></td><td></td><td>35</td><td>34</td><td>33</td></tr> <tr><td></td><td></td><td>73</td><td></td><td>32</td><td></td><td></td><td>29</td><td>28</td><td>27</td><td></td><td>24</td><td>23</td><td></td><td></td><td></td><td></td><td>19</td><td>18</td><td>17</td></tr> <tr><td></td><td></td><td></td><td></td><td>16</td><td>14</td><td>13</td><td>12</td><td>11</td><td></td><td>9</td><td>8</td><td>7</td><td>6</td><td>5</td><td>4</td><td>3</td><td>2</td><td>1</td><td></td></tr> </table>	72	71	70	69	68	67	66		64	63	62		60	59				55	54	53	52			49	48	46	44	43	42			40	39					35	34	33			73		32			29	28	27		24	23					19	18	17					16	14	13	12	11		9	8	7	6	5	4	3	2	1			
72	71	70	69	68	67	66		64	63	62		60	59				55	54	53																																																																						
52			49	48	46	44	43	42			40	39					35	34	33																																																																						
		73		32			29	28	27		24	23					19	18	17																																																																						
				16	14	13	12	11		9	8	7	6	5	4	3	2	1																																																																							
AVAILABLE	NOT APPLICABLE	34566-2873	G	0	B	ST GRY	<table border="1"> <tr><td>72</td><td>71</td><td>70</td><td>69</td><td>68</td><td>67</td><td>66</td><td></td><td></td><td></td><td></td><td></td><td></td><td>59</td><td>58</td><td>57</td><td>56</td><td>55</td><td></td><td>53</td></tr> <tr><td>52</td><td>51</td><td>50</td><td>49</td><td>48</td><td>47</td><td></td><td></td><td></td><td></td><td></td><td></td><td></td><td>39</td><td>38</td><td>37</td><td>36</td><td>35</td><td></td><td>33</td></tr> <tr><td></td><td></td><td>73</td><td></td><td></td><td></td><td></td><td></td><td></td><td></td><td></td><td></td><td></td><td>23</td><td>22</td><td>21</td><td></td><td></td><td></td><td></td></tr> <tr><td></td><td></td><td></td><td></td><td></td><td>15</td><td></td><td></td><td></td><td>11</td><td>10</td><td></td><td>8</td><td></td><td>6</td><td>5</td><td>4</td><td>3</td><td></td><td></td></tr> </table>	72	71	70	69	68	67	66							59	58	57	56	55		53	52	51	50	49	48	47								39	38	37	36	35		33			73											23	22	21										15				11	10		8		6	5	4	3				
72	71	70	69	68	67	66							59	58	57	56	55		53																																																																						
52	51	50	49	48	47								39	38	37	36	35		33																																																																						
		73											23	22	21																																																																										
					15				11	10		8		6	5	4	3																																																																								
AVAILABLE	NOT APPLICABLE	34566-2883	G	0	A	BLACK	<table border="1"> <tr><td></td><td></td><td>70</td><td>69</td><td></td><td></td><td></td><td></td><td>63</td><td>62</td><td>61</td><td></td><td></td><td></td><td>58</td><td>57</td><td>56</td><td>55</td><td>54</td><td>53</td></tr> <tr><td>52</td><td>51</td><td></td><td>49</td><td></td><td></td><td></td><td></td><td>44</td><td>43</td><td>42</td><td>41</td><td></td><td></td><td></td><td></td><td>37</td><td>36</td><td></td><td>34</td></tr> <tr><td></td><td></td><td>73</td><td></td><td>32</td><td></td><td></td><td></td><td>29</td><td>28</td><td>27</td><td>26</td><td></td><td></td><td></td><td></td><td></td><td>19</td><td>18</td><td></td></tr> <tr><td></td><td></td><td></td><td></td><td>16</td><td></td><td></td><td></td><td>13</td><td>12</td><td>11</td><td>10</td><td></td><td></td><td></td><td></td><td></td><td>3</td><td></td><td></td></tr> </table>			70	69					63	62	61				58	57	56	55	54	53	52	51		49					44	43	42	41					37	36		34			73		32				29	28	27	26						19	18						16				13	12	11	10						3				
		70	69					63	62	61				58	57	56	55	54	53																																																																						
52	51		49					44	43	42	41					37	36		34																																																																						
		73		32				29	28	27	26						19	18																																																																							
				16				13	12	11	10						3																																																																								

ENTER DESCRIPTION ELEC NO: UAU2013-0662 DRAWN BY: CHKO CHKD: APPR:WKSHY 2012/11/21 REV: 06	QUALITY SYMBOLS	GENERAL TOLERANCES (UNLESS SPECIFIED)	DIMENSION STYLE	SCALE	DESIGN UNITS	THIRD ANGLE PROJECTION	
	$\nabla=0$ $\nabla=0$ $\nabla=0$	4 PLACES ±--- INCH 3 PLACES ±--- INCH 2 PLACES ±--- INCH 1 PLACE ±--- INCH 0 PLACE ±--- INCH	mm INCH ANGULAR ±--- DRAFT WHERE APPLICABLE MUST REMAIN WITHIN DIMENSIONS	MM ONLY DRAWN BY: SKRA JENDRANA 2011/02/14 CHECKED BY: MVANSLAMBROU 2011/02/14 APPROVED BY: DATE		METRIC	MX123 66/73/80CKT HRNS CONN ASSY molex
							MATERIAL NO. SD-34566-001 DOCUMENT NO. SD-34566-001 SHEET NO. 33 OF 59
				SEE BOM TABLE			THIS DRAWING CONTAINS INFORMATION THAT IS PROPRIETARY TO MOLEX INCORPORATED AND SHOULD NOT BE USED WITHOUT WRITTEN PERMISSION

STATUS	GM PART #	MATERIAL #	PART/MATERIAL REVISION	WIRE DRESS OPTION	KEY OPTION	COLOR (TPA)	NUMBERS INDICATE CAVITIES OPEN FOR CIRCUITS																																																																	
AVAILABLE	NOT APPLICABLE	34566-2893	G	0	A	BLACK	<table border="1"> <tr><td>72</td><td></td><td>69</td><td>67</td><td>65</td><td>63</td><td></td><td>60</td><td></td><td>57</td><td>56</td><td></td><td>53</td></tr> <tr><td></td><td></td><td>49</td><td>47</td><td>46</td><td>44</td><td>43</td><td></td><td>40</td><td></td><td>37</td><td>36</td><td>35</td><td>33</td></tr> <tr><td></td><td>73</td><td></td><td>31</td><td>30</td><td>29</td><td>28</td><td></td><td>24</td><td></td><td>21</td><td>20</td><td></td><td>17</td></tr> <tr><td></td><td></td><td></td><td>16</td><td>15</td><td>14</td><td>13</td><td></td><td>11</td><td>10</td><td></td><td>5</td><td>4</td><td>3</td><td>2</td><td>1</td></tr> </table>	72		69	67	65	63		60		57	56		53			49	47	46	44	43		40		37	36	35	33		73		31	30	29	28		24		21	20		17				16	15	14	13		11	10		5	4	3	2	1								
72		69	67	65	63		60		57	56		53																																																												
		49	47	46	44	43		40		37	36	35	33																																																											
	73		31	30	29	28		24		21	20		17																																																											
			16	15	14	13		11	10		5	4	3	2	1																																																									
AVAILABLE	NOT APPLICABLE	34566-2913	G	0	B	ST GRAY	<table border="1"> <tr><td></td><td></td><td>68</td><td>67</td><td></td><td>64</td><td></td><td></td><td></td><td>58</td><td></td><td></td><td></td><td></td><td></td><td></td></tr> <tr><td></td><td></td><td></td><td></td><td>46</td><td>45</td><td></td><td></td><td></td><td>38</td><td></td><td></td><td></td><td></td><td></td><td></td></tr> <tr><td></td><td>73</td><td></td><td>32</td><td>30</td><td>29</td><td>28</td><td>27</td><td></td><td></td><td>22</td><td></td><td></td><td></td><td></td><td>17</td></tr> <tr><td></td><td></td><td></td><td></td><td>15</td><td>14</td><td>13</td><td></td><td>10</td><td></td><td></td><td></td><td></td><td></td><td></td><td>1</td></tr> </table>			68	67		64				58											46	45				38								73		32	30	29	28	27			22					17					15	14	13		10							1	
		68	67		64				58																																																															
				46	45				38																																																															
	73		32	30	29	28	27			22					17																																																									
				15	14	13		10							1																																																									
AVAILABLE	NOT APPLICABLE	34566-2923	G	0	B	ST GRAY	<table border="1"> <tr><td></td><td></td><td>68</td><td>67</td><td></td><td>64</td><td></td><td></td><td></td><td></td><td></td><td></td><td></td><td></td><td></td><td></td></tr> <tr><td></td><td></td><td></td><td></td><td>46</td><td>45</td><td></td><td></td><td></td><td></td><td></td><td></td><td></td><td></td><td></td><td></td></tr> <tr><td></td><td>73</td><td></td><td>32</td><td>30</td><td>29</td><td>28</td><td>27</td><td></td><td></td><td></td><td></td><td></td><td></td><td></td><td>17</td></tr> <tr><td></td><td></td><td></td><td></td><td>15</td><td>14</td><td>13</td><td></td><td>10</td><td></td><td></td><td></td><td></td><td></td><td></td><td></td></tr> </table>			68	67		64															46	45												73		32	30	29	28	27								17					15	14	13		10								
		68	67		64																																																																			
				46	45																																																																			
	73		32	30	29	28	27								17																																																									
				15	14	13		10																																																																
AVAILABLE	NOT APPLICABLE	34566-2933	G	0	A	BLACK	<table border="1"> <tr><td>72</td><td></td><td>69</td><td>67</td><td>65</td><td>63</td><td></td><td>60</td><td></td><td>57</td><td>56</td><td></td><td>53</td></tr> <tr><td></td><td></td><td>49</td><td>47</td><td>46</td><td>44</td><td>43</td><td></td><td>40</td><td></td><td>37</td><td>36</td><td>35</td><td>33</td></tr> <tr><td></td><td>73</td><td></td><td>31</td><td>30</td><td>29</td><td>28</td><td></td><td>24</td><td></td><td>21</td><td>20</td><td></td><td>17</td></tr> <tr><td></td><td></td><td></td><td>16</td><td>15</td><td>14</td><td>13</td><td></td><td>11</td><td>10</td><td></td><td>5</td><td>4</td><td>3</td><td>2</td><td>1</td></tr> </table>	72		69	67	65	63		60		57	56		53			49	47	46	44	43		40		37	36	35	33		73		31	30	29	28		24		21	20		17				16	15	14	13		11	10		5	4	3	2	1								
72		69	67	65	63		60		57	56		53																																																												
		49	47	46	44	43		40		37	36	35	33																																																											
	73		31	30	29	28		24		21	20		17																																																											
			16	15	14	13		11	10		5	4	3	2	1																																																									
AVAILABLE	NOT APPLICABLE	34566-2943	G	0	B	ST GRAY	<table border="1"> <tr><td></td><td></td><td>68</td><td>67</td><td></td><td>64</td><td>63</td><td></td><td></td><td>59</td><td>57</td><td></td><td></td><td></td><td></td><td></td></tr> <tr><td></td><td></td><td></td><td></td><td>46</td><td>45</td><td>43</td><td></td><td></td><td>39</td><td>37</td><td></td><td></td><td></td><td></td><td></td></tr> <tr><td></td><td>73</td><td></td><td>32</td><td>30</td><td>29</td><td>28</td><td>27</td><td></td><td></td><td>21</td><td></td><td></td><td></td><td></td><td></td></tr> <tr><td></td><td></td><td></td><td></td><td></td><td></td><td></td><td>10</td><td></td><td></td><td>6</td><td>5</td><td>4</td><td>3</td><td></td><td></td></tr> </table>			68	67		64	63			59	57										46	45	43			39	37							73		32	30	29	28	27			21													10			6	5	4	3			
		68	67		64	63			59	57																																																														
				46	45	43			39	37																																																														
	73		32	30	29	28	27			21																																																														
							10			6	5	4	3																																																											
AVAILABLE	NOT APPLICABLE	34566-2953	G	0	B	ST GRAY	<table border="1"> <tr><td></td><td></td><td>68</td><td>67</td><td></td><td>64</td><td>63</td><td></td><td></td><td>59</td><td></td><td></td><td></td><td></td><td></td><td>34</td></tr> <tr><td></td><td></td><td></td><td></td><td>46</td><td>45</td><td>43</td><td></td><td></td><td>39</td><td></td><td></td><td></td><td></td><td></td><td></td></tr> <tr><td></td><td>73</td><td></td><td>32</td><td>30</td><td>29</td><td>28</td><td>27</td><td></td><td></td><td></td><td></td><td></td><td></td><td></td><td></td></tr> <tr><td></td><td></td><td></td><td></td><td></td><td></td><td></td><td>10</td><td></td><td></td><td>6</td><td>5</td><td>4</td><td>3</td><td></td><td></td></tr> </table>			68	67		64	63			59						34					46	45	43			39								73		32	30	29	28	27																10			6	5	4	3			
		68	67		64	63			59						34																																																									
				46	45	43			39																																																															
	73		32	30	29	28	27																																																																	
							10			6	5	4	3																																																											
AVAILABLE	NOT APPLICABLE	34566-2963	G	0	H	ST GRAY	<table border="1"> <tr><td></td><td>79</td><td></td><td></td><td>74</td><td>73</td><td>72</td><td>71</td><td>69</td><td>68</td><td>67</td><td></td><td>64</td><td>62</td><td>61</td></tr> <tr><td></td><td>59</td><td></td><td></td><td>54</td><td>53</td><td>52</td><td></td><td>49</td><td>48</td><td>47</td><td></td><td></td><td>42</td><td>41</td></tr> <tr><td></td><td></td><td>38</td><td></td><td></td><td>33</td><td></td><td></td><td>29</td><td>27</td><td>25</td><td></td><td></td><td></td><td>21</td></tr> <tr><td></td><td></td><td></td><td></td><td>15</td><td>14</td><td></td><td>11</td><td>10</td><td>9</td><td>8</td><td>7</td><td></td><td></td><td></td></tr> </table>		79			74	73	72	71	69	68	67		64	62	61		59			54	53	52		49	48	47			42	41			38			33			29	27	25				21					15	14		11	10	9	8	7								
	79			74	73	72	71	69	68	67		64	62	61																																																										
	59			54	53	52		49	48	47			42	41																																																										
		38			33			29	27	25				21																																																										
				15	14		11	10	9	8	7																																																													
AVAILABLE	NOT APPLICABLE	34566-2973	G	0	G	BLUE	<table border="1"> <tr><td>80</td><td>78</td><td>77</td><td>75</td><td>74</td><td>73</td><td>72</td><td>70</td><td>69</td><td>67</td><td>65</td><td>64</td><td>63</td><td>62</td><td></td><td></td></tr> <tr><td>60</td><td>58</td><td>57</td><td></td><td>55</td><td>54</td><td>52</td><td>51</td><td>50</td><td>49</td><td>47</td><td>45</td><td></td><td></td><td></td><td></td></tr> <tr><td>40</td><td>38</td><td>37</td><td></td><td></td><td>33</td><td>32</td><td>31</td><td></td><td></td><td>27</td><td>26</td><td>25</td><td>24</td><td></td><td></td></tr> <tr><td>20</td><td>18</td><td>17</td><td></td><td></td><td></td><td></td><td></td><td>10</td><td>9</td><td>8</td><td>6</td><td>5</td><td></td><td>3</td><td>2</td><td>1</td></tr> </table>	80	78	77	75	74	73	72	70	69	67	65	64	63	62			60	58	57		55	54	52	51	50	49	47	45					40	38	37			33	32	31			27	26	25	24			20	18	17						10	9	8	6	5		3	2	1
80	78	77	75	74	73	72	70	69	67	65	64	63	62																																																											
60	58	57		55	54	52	51	50	49	47	45																																																													
40	38	37			33	32	31			27	26	25	24																																																											
20	18	17						10	9	8	6	5		3	2	1																																																								

ENTER DESCRIPTION EC NO: UAU2013-0662 DRAWN BY: 2012/11/01 CHKD: APPR: IKOSHY 2012/11/21 REV: T86	QUALITY SYMBOLS	GENERAL TOLERANCES (UNLESS SPECIFIED)	DIMENSION STYLE	SCALE	DESIGN UNITS	THIRD ANGLE PROJECTION	
	∇=0 ∇=0 ∇=0	4 PLACES ±---+--- 3 PLACES ±---+--- 2 PLACES ±---+--- 1 PLACE ±---+--- 0 PLACE ±---+---	mm INCH ANGULAR ±---° DRAFT WHERE APPLICABLE MUST REMAIN WITHIN DIMENSIONS	MM ONLY DRAWN BY: SKRA JENDRANA 2011/02/14 CHECKED BY: DATE MVANSLAMBROU 2011/02/14 APPROVED BY: DATE	DATE DATE DATE	METRIC	TITLE MX123 66/73/80CKT HRNS CONN ASSY molex
	MATERIAL NO.	DOCUMENT NO.	SEE BOM TABLE				
		SD-34566-001	SHEET NO. 34 OF 59				

THIS DRAWING CONTAINS INFORMATION THAT IS PROPRIETARY TO MOLEX INCORPORATED AND SHOULD NOT BE USED WITHOUT WRITTEN PERMISSION

STATUS	GM PART #	MATERIAL #	PART/MATERIAL REVISION	WIRE DRESS OPTION	KEY OPTION	COLOR (TPA)	NUMBERS INDICATE CAVITIES OPEN FOR CIRCUITS																																																																																								
AVAILABLE	NOT APPLICABLE	34566-2983	G	9	A	BLACK	<table border="1"> <tr><td></td><td></td><td>70</td><td>69</td><td></td><td></td><td></td><td></td><td></td><td></td><td>63</td><td>62</td><td>61</td><td></td><td></td><td>58</td><td>57</td><td>56</td><td>55</td><td>54</td><td>53</td></tr> <tr><td>52</td><td>51</td><td></td><td>49</td><td></td><td></td><td></td><td></td><td></td><td></td><td>44</td><td>43</td><td>42</td><td>41</td><td></td><td></td><td>37</td><td>36</td><td></td><td></td><td>34</td></tr> <tr><td></td><td></td><td></td><td></td><td>73</td><td></td><td></td><td></td><td></td><td></td><td></td><td></td><td></td><td></td><td></td><td></td><td></td><td></td><td></td><td></td><td>19</td><td>18</td><td>17</td></tr> <tr><td></td><td></td><td></td><td></td><td></td><td></td><td></td><td></td><td></td><td></td><td></td><td></td><td></td><td></td><td></td><td></td><td></td><td></td><td></td><td></td><td>3</td><td>2</td><td>1</td></tr> </table>			70	69							63	62	61			58	57	56	55	54	53	52	51		49							44	43	42	41			37	36			34					73																19	18	17																					3	2	1
		70	69							63	62	61			58	57	56	55	54	53																																																																											
52	51		49							44	43	42	41			37	36			34																																																																											
				73																19	18	17																																																																									
																				3	2	1																																																																									
AVAILABLE	NOT APPLICABLE	34566-2993	G	9	B	ST GRY	<table border="1"> <tr><td>72</td><td>71</td><td>70</td><td></td><td>68</td><td>67</td><td>66</td><td></td><td></td><td></td><td>62</td><td>61</td><td>60</td><td>59</td><td>58</td><td>57</td><td>56</td><td>55</td><td>54</td><td>53</td></tr> <tr><td>52</td><td>51</td><td>50</td><td></td><td>48</td><td>47</td><td>46</td><td></td><td></td><td></td><td>42</td><td>41</td><td>40</td><td>39</td><td>38</td><td>37</td><td>36</td><td>35</td><td>34</td><td>33</td></tr> <tr><td></td><td></td><td></td><td></td><td></td><td></td><td></td><td></td><td></td><td></td><td></td><td></td><td></td><td></td><td></td><td></td><td></td><td></td><td></td><td></td><td></td><td></td><td></td></tr> <tr><td></td><td></td><td></td><td></td><td></td><td></td><td></td><td></td><td></td><td></td><td></td><td></td><td></td><td></td><td></td><td></td><td></td><td></td><td></td><td></td><td></td><td></td><td></td></tr> </table>	72	71	70		68	67	66				62	61	60	59	58	57	56	55	54	53	52	51	50		48	47	46				42	41	40	39	38	37	36	35	34	33																																																
72	71	70		68	67	66				62	61	60	59	58	57	56	55	54	53																																																																												
52	51	50		48	47	46				42	41	40	39	38	37	36	35	34	33																																																																												
AVAILABLE	NOT APPLICABLE	34566-3013	G	9	C	BLUE	<table border="1"> <tr><td>72</td><td>71</td><td>70</td><td>69</td><td>68</td><td>67</td><td>66</td><td></td><td></td><td></td><td>63</td><td>62</td><td></td><td>59</td><td></td><td>57</td><td>56</td><td>55</td><td></td><td>53</td></tr> <tr><td>52</td><td>51</td><td></td><td></td><td></td><td></td><td></td><td></td><td></td><td></td><td>46</td><td>44</td><td></td><td>42</td><td>40</td><td>39</td><td>38</td><td></td><td></td><td>34</td><td>33</td></tr> <tr><td></td><td></td><td></td><td></td><td></td><td></td><td></td><td></td><td></td><td></td><td></td><td></td><td></td><td></td><td></td><td></td><td></td><td></td><td></td><td></td><td></td><td></td><td></td></tr> <tr><td></td><td></td><td></td><td></td><td></td><td></td><td></td><td></td><td></td><td></td><td></td><td></td><td></td><td></td><td></td><td></td><td></td><td></td><td></td><td></td><td></td><td></td><td></td></tr> </table>	72	71	70	69	68	67	66				63	62		59		57	56	55		53	52	51									46	44		42	40	39	38			34	33																																															
72	71	70	69	68	67	66				63	62		59		57	56	55		53																																																																												
52	51									46	44		42	40	39	38			34	33																																																																											
AVAILABLE	NOT APPLICABLE	34566-3023	G	0	G	BLUE	<table border="1"> <tr><td></td><td>79</td><td></td><td></td><td>76</td><td></td><td></td><td></td><td></td><td></td><td>71</td><td></td><td></td><td>68</td><td>66</td><td></td><td></td><td></td><td></td><td></td><td>61</td></tr> <tr><td></td><td>59</td><td></td><td></td><td>56</td><td></td><td></td><td>53</td><td></td><td></td><td></td><td></td><td></td><td>48</td><td>46</td><td></td><td>44</td><td>43</td><td>42</td><td>41</td><td></td></tr> <tr><td></td><td>39</td><td></td><td></td><td>36</td><td>35</td><td>34</td><td></td><td></td><td></td><td></td><td></td><td>30</td><td>29</td><td>28</td><td></td><td></td><td></td><td></td><td>23</td><td>22</td><td>21</td></tr> <tr><td></td><td>19</td><td></td><td></td><td>16</td><td>15</td><td>14</td><td>13</td><td>12</td><td>11</td><td></td><td></td><td></td><td>7</td><td></td><td></td><td>4</td><td></td><td></td><td></td><td></td><td></td></tr> </table>		79			76						71			68	66						61		59			56			53						48	46		44	43	42	41			39			36	35	34						30	29	28					23	22	21		19			16	15	14	13	12	11				7			4							
	79			76						71			68	66						61																																																																											
	59			56			53						48	46		44	43	42	41																																																																												
	39			36	35	34						30	29	28					23	22	21																																																																										
	19			16	15	14	13	12	11				7			4																																																																															
AVAILABLE	NOT APPLICABLE	34566-3033	G	0	H	ST GRY	<table border="1"> <tr><td>80</td><td>78</td><td>77</td><td>76</td><td>75</td><td></td><td></td><td></td><td></td><td></td><td>70</td><td></td><td></td><td></td><td>66</td><td>65</td><td></td><td>63</td><td></td><td></td><td></td><td></td></tr> <tr><td>60</td><td>58</td><td>57</td><td>56</td><td>55</td><td></td><td></td><td></td><td></td><td></td><td>51</td><td>50</td><td></td><td></td><td>46</td><td>45</td><td>44</td><td>43</td><td></td><td></td><td></td><td></td></tr> <tr><td>40</td><td>39</td><td></td><td>37</td><td>36</td><td>35</td><td>34</td><td></td><td></td><td></td><td>32</td><td>31</td><td>30</td><td></td><td>28</td><td>26</td><td></td><td>24</td><td>23</td><td>22</td><td></td><td></td></tr> <tr><td>20</td><td>19</td><td>18</td><td>17</td><td>16</td><td></td><td></td><td></td><td></td><td></td><td></td><td></td><td></td><td></td><td></td><td>6</td><td>5</td><td>4</td><td>3</td><td>2</td><td>1</td><td></td></tr> </table>	80	78	77	76	75						70				66	65		63					60	58	57	56	55						51	50			46	45	44	43					40	39		37	36	35	34				32	31	30		28	26		24	23	22			20	19	18	17	16											6	5	4	3	2	1	
80	78	77	76	75						70				66	65		63																																																																														
60	58	57	56	55						51	50			46	45	44	43																																																																														
40	39		37	36	35	34				32	31	30		28	26		24	23	22																																																																												
20	19	18	17	16											6	5	4	3	2	1																																																																											
AVAILABLE	NOT APPLICABLE	34566-3043	G	0	C	BLUE	<table border="1"> <tr><td>72</td><td>70</td><td></td><td>68</td><td></td><td>66</td><td></td><td></td><td></td><td></td><td>63</td><td>62</td><td></td><td>59</td><td></td><td>57</td><td></td><td></td><td></td><td></td><td>53</td></tr> <tr><td>52</td><td>51</td><td></td><td>48</td><td>47</td><td>46</td><td></td><td></td><td></td><td></td><td>44</td><td>42</td><td></td><td>40</td><td>39</td><td></td><td></td><td></td><td></td><td></td><td>34</td><td>33</td></tr> <tr><td></td><td></td><td></td><td></td><td></td><td></td><td></td><td></td><td></td><td></td><td></td><td></td><td></td><td></td><td></td><td></td><td></td><td></td><td></td><td></td><td></td><td></td></tr> <tr><td></td><td></td><td></td><td></td><td></td><td></td><td></td><td></td><td></td><td></td><td></td><td></td><td></td><td></td><td></td><td></td><td></td><td></td><td></td><td></td><td></td><td></td></tr> </table>	72	70		68		66					63	62		59		57					53	52	51		48	47	46					44	42		40	39						34	33																																													
72	70		68		66					63	62		59		57					53																																																																											
52	51		48	47	46					44	42		40	39						34	33																																																																										
AVAILABLE	NOT APPLICABLE	34566-3053	G	0	C	BLUE	<table border="1"> <tr><td>72</td><td>70</td><td></td><td>68</td><td></td><td>66</td><td></td><td></td><td></td><td></td><td>63</td><td>62</td><td></td><td>59</td><td></td><td>57</td><td></td><td></td><td></td><td></td><td>53</td></tr> <tr><td>52</td><td>51</td><td></td><td>48</td><td>47</td><td>46</td><td></td><td></td><td></td><td></td><td>44</td><td>42</td><td></td><td>40</td><td>39</td><td>38</td><td></td><td></td><td></td><td></td><td>34</td><td>33</td></tr> <tr><td></td><td></td><td></td><td></td><td></td><td></td><td></td><td></td><td></td><td></td><td></td><td></td><td></td><td></td><td></td><td></td><td></td><td></td><td></td><td></td><td></td><td></td></tr> <tr><td></td><td></td><td></td><td></td><td></td><td></td><td></td><td></td><td></td><td></td><td></td><td></td><td></td><td></td><td></td><td></td><td></td><td></td><td></td><td></td><td></td><td></td></tr> </table>	72	70		68		66					63	62		59		57					53	52	51		48	47	46					44	42		40	39	38					34	33																																													
72	70		68		66					63	62		59		57					53																																																																											
52	51		48	47	46					44	42		40	39	38					34	33																																																																										
AVAILABLE	NOT APPLICABLE	34566-3063	G	0	A	BLACK	<table border="1"> <tr><td></td><td>71</td><td></td><td>69</td><td></td><td></td><td></td><td></td><td></td><td></td><td>65</td><td>64</td><td>63</td><td></td><td></td><td>60</td><td>58</td><td>57</td><td>56</td><td>55</td><td>54</td><td>53</td></tr> <tr><td>52</td><td>51</td><td></td><td>49</td><td></td><td></td><td></td><td></td><td></td><td></td><td>45</td><td>44</td><td>43</td><td>42</td><td>41</td><td></td><td></td><td>37</td><td>36</td><td>35</td><td>34</td><td>33</td></tr> <tr><td></td><td></td><td></td><td></td><td></td><td></td><td></td><td></td><td></td><td></td><td></td><td></td><td></td><td></td><td></td><td></td><td></td><td></td><td></td><td></td><td></td><td></td></tr> <tr><td></td><td></td><td></td><td></td><td></td><td></td><td></td><td></td><td></td><td></td><td></td><td></td><td></td><td></td><td></td><td></td><td></td><td></td><td></td><td></td><td></td><td></td></tr> </table>		71		69							65	64	63			60	58	57	56	55	54	53	52	51		49							45	44	43	42	41			37	36	35	34	33																																												
	71		69							65	64	63			60	58	57	56	55	54	53																																																																										
52	51		49							45	44	43	42	41			37	36	35	34	33																																																																										

ENTER DESCRIPTION EC NO: UAU2013-0662 DRAWN BY: 2012/11/01 CHKD: 2012/11/21 APPR: WOSHY REV:	QUALITY SYMBOLS	GENERAL TOLERANCES (UNLESS SPECIFIED)	DIMENSION STYLE	SCALE	DESIGN UNITS	THIRD ANGLE PROJECTION	
	$\nabla=0$ $\nabla=0$ $\nabla=0$	4 PLACES ±---+--- 3 PLACES ±---+--- 2 PLACES ±---+--- 1 PLACE ±---+--- 0 PLACE ±---+---	mm INCH ±---+--- ±---+--- ±---+--- ±---+--- ±---+--- ±---+--- ±---+--- ±---+---	MM ONLY		METRIC	
		ANGULAR ±---+--- DRAFT WHERE APPLICABLE MUST REMAIN WITHIN DIMENSIONS	DRAWN BY: SKRAJENDRANA 2011/02/14 CHECKED BY: MYANSLAMBROU 2011/02/14 APPROVED BY:	DATE	DATE	DATE	MX123 66/73/80CKT HRNS CONN ASSY
				SEE BOM TABLE			MATERIAL NO. SD-34566-001 DOCUMENT NO. SD-34566-001 SHEET NO. 36 OF 59

STATUS	GM PART #	MATERIAL #	PART/MATERIAL REVISION	WIRE DRESS OPTION	KEY OPTION	COLOR (TPA)	NUMBERS INDICATE CAVITIES OPEN FOR CIRCUITS															
AVAILABLE	NOT APPLICABLE	34566-3073	G	0	A	BLACK	71	69			65	64	63		60		57	56	55	54	53	
							52	51	49			45	44	43	42	41		37	36	35	34	33
							73			32	30		28	26		23				19	18	
									16			12	10		8	7	6			3		
AVAILABLE	NOT APPLICABLE	34566-3083	G	0	A	BLACK	71	69			65	64	63		60		58	57	56	55	54	53
							52	51	49			45	44	43	42	41		37	36	35	34	33
							73			32	30		28	26						19	18	
									16			11	10							3		
AVAILABLE	NOT APPLICABLE	34566-3093	G	0	A	BLACK	71	69			64	63	62		60		57	56	55	54	53	
							52	51	49			45	44	43	42	41		37	36	35	34	33
							73			32	30		28	26		23				19	18	
									16			12	10							3		
AVAILABLE	NOT APPLICABLE	34566-3113	G	0	A	BLACK	71	69			65	64	63		60		57	56	55	54	53	
							52	51	49			45	44	43	42	41		37	36	35	34	33
							73			32	30		28	26		23	21			19	18	
									16			12	10		8		5			3		
AVAILABLE	NOT APPLICABLE	34566-3123	G	0	B	ST GRY	72	70	68	66					60	59			55	54	53	
							52	51	50	48	46				40	39			35	34	33	
							73			32	31	30	29	28	27	26	25	24				
									16					10	9	8						
AVAILABLE	NOT APPLICABLE	34566-3133	G	0	C	BLUE	72	70	68	67	66		63	62		59	57			53		
							52	51		48	47	46	44	42	40	39				34	33	
							73			32		30		26	25		22	21	20			
									15	14			10	9		6	5	4				
AVAILABLE	NOT APPLICABLE	34566-3143	G	0	C	BLUE	72	70			66		63	62		59	57			53		
							52	51			46	44	42	40	39		37	36		34	33	
							73			32		30		26	25		22	21				
									15	14			10	9		6						
AVAILABLE	NOT APPLICABLE	34566-3153	G	0	A	BLACK		70	69						63			58	56	54		
							52	51	49	47		44	43	42	41			36	34			
							73			32			28	26					19	18		
									16				12	10					3			

ENTER DESCRIPTION ELEC NO: UAU2013-0662 DRAWN BY: CHKO: CHKD: APPR: IKOSHY REV: 2012/11/21	QUALITY SYMBOLS	GENERAL TOLERANCES (UNLESS SPECIFIED)	DIMENSION STYLE	SCALE	DESIGN UNITS	THIRD ANGLE PROJECTION
	▽=0	4 PLACES ±---+---	MM ONLY		METRIC	
	▽=0	3 PLACES ±---+---	INCH	DRAWN BY: SKRAJENDRANA	DATE: 2011/02/14	TITLE: MX123
	▽=0	2 PLACES ±---+---		CHECKED BY: MYANSLAMBROU	DATE: 2011/02/14	HRNS CONN ASSY
		1 PLACE ±---+---		APPROVED BY:	DATE:	molex
		0 PLACE ±---+---				DOCUMENT NO. SD-34566-001
		ANGULAR ±---+---				SHEET NO. 37 OF 59
		DRAFT WHERE APPLICABLE MUST REMAIN WITHIN DIMENSIONS				THIS DRAWING CONTAINS INFORMATION THAT IS PROPRIETARY TO MOLEX INCORPORATED AND SHOULD NOT BE USED WITHOUT WRITTEN PERMISSION

STATUS	GM PART #	MATERIAL #	PART/MATERIAL REVISION	WIRE DRESS OPTION	KEY OPTION	COLOR (TPA)	NUMBERS INDICATE CAVITIES OPEN FOR CIRCUITS																																																																			
AVAILABLE	NOT APPLICABLE	34566-3163	G	0	C	BLUE	<table border="1"> <tr><td>72</td><td>70</td><td></td><td></td><td></td><td></td><td>63</td><td>62</td><td></td><td>59</td><td>57</td><td>56</td><td>55</td><td>53</td></tr> <tr><td>52</td><td>51</td><td></td><td></td><td></td><td>46</td><td>44</td><td>42</td><td>40</td><td>39</td><td>37</td><td>36</td><td></td><td>34</td><td>33</td></tr> <tr><td></td><td></td><td>73</td><td></td><td></td><td>32</td><td>30</td><td></td><td>26</td><td>25</td><td></td><td>22</td><td>21</td><td>19</td><td>18</td></tr> <tr><td></td><td></td><td></td><td></td><td></td><td>15</td><td>14</td><td></td><td>10</td><td>9</td><td></td><td>6</td><td></td><td>3</td><td></td></tr> </table>	72	70					63	62		59	57	56	55	53	52	51				46	44	42	40	39	37	36		34	33			73			32	30		26	25		22	21	19	18						15	14		10	9		6		3									
72	70					63	62		59	57	56	55	53																																																													
52	51				46	44	42	40	39	37	36		34	33																																																												
		73			32	30		26	25		22	21	19	18																																																												
					15	14		10	9		6		3																																																													
AVAILABLE	NOT APPLICABLE	34566-3173	G	0	A	BLACK	<table border="1"> <tr><td></td><td>70</td><td>69</td><td></td><td></td><td></td><td>63</td><td></td><td></td><td></td><td>58</td><td>56</td><td>55</td><td>54</td></tr> <tr><td>52</td><td>51</td><td>49</td><td></td><td></td><td>47</td><td></td><td>44</td><td>43</td><td>42</td><td>41</td><td></td><td>36</td><td>34</td></tr> <tr><td></td><td></td><td></td><td>73</td><td></td><td>32</td><td></td><td>28</td><td>26</td><td></td><td></td><td></td><td>19</td><td>18</td><td>17</td></tr> <tr><td></td><td></td><td></td><td></td><td></td><td>16</td><td></td><td>12</td><td>10</td><td></td><td></td><td></td><td>3</td><td>2</td><td>1</td></tr> </table>		70	69				63				58	56	55	54	52	51	49			47		44	43	42	41		36	34				73		32		28	26				19	18	17						16		12	10				3	2	1									
	70	69				63				58	56	55	54																																																													
52	51	49			47		44	43	42	41		36	34																																																													
			73		32		28	26				19	18	17																																																												
					16		12	10				3	2	1																																																												
AVAILABLE	NOT APPLICABLE	34566-3183	G	0	C	BLUE	<table border="1"> <tr><td>72</td><td>70</td><td></td><td></td><td></td><td>66</td><td></td><td>63</td><td>62</td><td></td><td>59</td><td>57</td><td>56</td><td>55</td><td>53</td></tr> <tr><td>52</td><td>51</td><td></td><td></td><td></td><td>46</td><td>44</td><td>42</td><td>40</td><td>39</td><td></td><td></td><td></td><td></td><td>34</td><td>33</td></tr> <tr><td></td><td></td><td>73</td><td></td><td></td><td>30</td><td></td><td></td><td>26</td><td>25</td><td></td><td>22</td><td>21</td><td></td><td></td><td></td></tr> <tr><td></td><td></td><td></td><td></td><td></td><td>15</td><td>14</td><td></td><td>10</td><td>9</td><td></td><td>6</td><td></td><td></td><td></td><td></td></tr> </table>	72	70				66		63	62		59	57	56	55	53	52	51				46	44	42	40	39					34	33			73			30			26	25		22	21									15	14		10	9		6								
72	70				66		63	62		59	57	56	55	53																																																												
52	51				46	44	42	40	39					34	33																																																											
		73			30			26	25		22	21																																																														
					15	14		10	9		6																																																															
AVAILABLE	NOT APPLICABLE	34566-3193	G	0	A	BLACK	<table border="1"> <tr><td></td><td></td><td>69</td><td></td><td></td><td></td><td>63</td><td></td><td></td><td></td><td>58</td><td>56</td><td>55</td><td>54</td><td>53</td></tr> <tr><td>52</td><td>51</td><td>49</td><td></td><td></td><td></td><td>44</td><td>43</td><td>42</td><td>41</td><td></td><td></td><td>36</td><td>35</td><td>34</td><td>33</td></tr> <tr><td></td><td></td><td></td><td>73</td><td></td><td>32</td><td></td><td>28</td><td>26</td><td></td><td></td><td></td><td></td><td>19</td><td>18</td><td>17</td></tr> <tr><td></td><td></td><td></td><td></td><td></td><td>16</td><td></td><td>12</td><td>10</td><td></td><td></td><td></td><td></td><td>3</td><td>2</td><td>1</td></tr> </table>			69				63				58	56	55	54	53	52	51	49				44	43	42	41			36	35	34	33				73		32		28	26					19	18	17						16		12	10					3	2	1				
		69				63				58	56	55	54	53																																																												
52	51	49				44	43	42	41			36	35	34	33																																																											
			73		32		28	26					19	18	17																																																											
					16		12	10					3	2	1																																																											
AVAILABLE	NOT APPLICABLE	34566-3213	G	0	C	BLUE	<table border="1"> <tr><td>72</td><td>70</td><td></td><td></td><td></td><td>67</td><td>66</td><td></td><td>63</td><td>62</td><td></td><td>59</td><td></td><td>56</td><td></td><td>53</td></tr> <tr><td>52</td><td>51</td><td></td><td></td><td></td><td>46</td><td>44</td><td></td><td>42</td><td>40</td><td></td><td></td><td></td><td></td><td></td><td>34</td><td>33</td></tr> <tr><td></td><td></td><td>73</td><td></td><td></td><td>32</td><td>30</td><td></td><td></td><td>26</td><td>25</td><td></td><td>22</td><td>21</td><td></td><td></td><td></td></tr> <tr><td></td><td></td><td></td><td></td><td></td><td>15</td><td>14</td><td></td><td></td><td>10</td><td>9</td><td></td><td>6</td><td>5</td><td>4</td><td></td><td></td></tr> </table>	72	70				67	66		63	62		59		56		53	52	51				46	44		42	40						34	33			73			32	30			26	25		22	21									15	14			10	9		6	5	4		
72	70				67	66		63	62		59		56		53																																																											
52	51				46	44		42	40						34	33																																																										
		73			32	30			26	25		22	21																																																													
					15	14			10	9		6	5	4																																																												
AVAILABLE	NOT APPLICABLE	34566-3223	G	0	C	BLUE	<table border="1"> <tr><td>72</td><td>70</td><td></td><td></td><td></td><td>67</td><td>66</td><td></td><td>63</td><td>62</td><td></td><td>59</td><td>57</td><td></td><td></td><td>53</td></tr> <tr><td>52</td><td>51</td><td></td><td></td><td></td><td>46</td><td>44</td><td></td><td>42</td><td>40</td><td>39</td><td></td><td></td><td></td><td></td><td>34</td><td>33</td></tr> <tr><td></td><td></td><td>73</td><td></td><td></td><td>32</td><td>30</td><td></td><td>27</td><td>26</td><td>25</td><td></td><td>22</td><td>21</td><td></td><td></td><td></td></tr> <tr><td></td><td></td><td></td><td></td><td></td><td>15</td><td>14</td><td></td><td></td><td>10</td><td>9</td><td></td><td>6</td><td>5</td><td>4</td><td></td><td></td></tr> </table>	72	70				67	66		63	62		59	57			53	52	51				46	44		42	40	39					34	33			73			32	30		27	26	25		22	21									15	14			10	9		6	5	4		
72	70				67	66		63	62		59	57			53																																																											
52	51				46	44		42	40	39					34	33																																																										
		73			32	30		27	26	25		22	21																																																													
					15	14			10	9		6	5	4																																																												
AVAILABLE	NOT APPLICABLE	34566-3233	G	0	A	BLACK	<table border="1"> <tr><td></td><td>70</td><td>69</td><td></td><td></td><td></td><td>63</td><td>62</td><td>61</td><td></td><td>58</td><td>57</td><td>56</td><td>55</td><td>54</td><td>53</td></tr> <tr><td>52</td><td>51</td><td>49</td><td></td><td></td><td></td><td>44</td><td>43</td><td>42</td><td>41</td><td></td><td></td><td>37</td><td>36</td><td>34</td><td></td></tr> <tr><td></td><td></td><td></td><td>73</td><td></td><td>32</td><td></td><td>29</td><td>28</td><td>27</td><td>26</td><td></td><td></td><td></td><td>19</td><td>18</td></tr> <tr><td></td><td></td><td></td><td></td><td></td><td>16</td><td>15</td><td>13</td><td>12</td><td>11</td><td>10</td><td></td><td></td><td></td><td>3</td><td></td></tr> </table>		70	69				63	62	61		58	57	56	55	54	53	52	51	49				44	43	42	41			37	36	34					73		32		29	28	27	26				19	18						16	15	13	12	11	10				3				
	70	69				63	62	61		58	57	56	55	54	53																																																											
52	51	49				44	43	42	41			37	36	34																																																												
			73		32		29	28	27	26				19	18																																																											
					16	15	13	12	11	10				3																																																												
AVAILABLE	NOT APPLICABLE	34566-3243	G	0	C	BLUE	<table border="1"> <tr><td>72</td><td>70</td><td></td><td></td><td></td><td>66</td><td></td><td>63</td><td>62</td><td></td><td>59</td><td>57</td><td></td><td></td><td></td><td>53</td></tr> <tr><td>52</td><td>51</td><td></td><td></td><td></td><td>46</td><td>44</td><td></td><td>42</td><td>40</td><td>39</td><td></td><td></td><td></td><td></td><td>34</td><td>33</td></tr> <tr><td></td><td></td><td>73</td><td></td><td></td><td>32</td><td>30</td><td></td><td></td><td>26</td><td>25</td><td></td><td>22</td><td>21</td><td></td><td></td><td></td></tr> <tr><td></td><td></td><td></td><td></td><td></td><td>15</td><td>14</td><td></td><td></td><td>10</td><td>9</td><td></td><td>6</td><td>5</td><td>4</td><td></td><td></td></tr> </table>	72	70				66		63	62		59	57				53	52	51				46	44		42	40	39					34	33			73			32	30			26	25		22	21									15	14			10	9		6	5	4		
72	70				66		63	62		59	57				53																																																											
52	51				46	44		42	40	39					34	33																																																										
		73			32	30			26	25		22	21																																																													
					15	14			10	9		6	5	4																																																												

ENTER DESCRIPTION EC NO: UAU2013-0662 DRAWN BY: DRINKATE CHKD: FB8 APPR: WOSHY DATE: 2012/11/21 REV:	QUALITY SYMBOLS	GENERAL TOLERANCES (UNLESS SPECIFIED)	DIMENSION STYLE	SCALE	DESIGN UNITS	THIRD ANGLE PROJECTION	
	$\nabla=0$ $\nabla=0$ $\nabla=0$	4 PLACES ±---+--- 3 PLACES ±---+--- 2 PLACES ±---+--- 1 PLACE ±---+--- 0 PLACE ±---+---	mm INCH ANGULAR ±---° DRAFT WHERE APPLICABLE MUST REMAIN WITHIN DIMENSIONS	MM ONLY DRAWN BY: SKRAJENDRANA CHECKED BY: MYANSLAMBROU APPROVED BY:	DATE: 2011/02/14 DATE: 2011/02/14 DATE:	METRIC MX123 66/73/80CKT HRNS CONN ASSY molex	<input checked="" type="checkbox"/>
	MATERIAL NO.	DOCUMENT NO.	SHEET NO. 38 OF 59 THIS DRAWING CONTAINS INFORMATION THAT IS PROPRIETARY TO MOLEX INCORPORATED AND SHOULD NOT BE USED WITHOUT WRITTEN PERMISSION				
	SEE BOM TABLE	SD-34566-001					

STATUS	GM PART #	MATERIAL #	PART/MATERIAL REVISION	WIRE DRESS OPTION	KEY OPTION	COLOR (TPA)	NUMBERS INDICATE CAVITIES OPEN FOR CIRCUITS																																																																								
AVAILABLE	NOT APPLICABLE	34566-3253	G	0	A	BLACK	<table border="1"> <tr><td></td><td>70</td><td>69</td><td></td><td></td><td></td><td>63</td><td></td><td></td><td></td><td>58</td><td>56</td><td>55</td><td>54</td><td>53</td></tr> <tr><td>52</td><td>51</td><td>49</td><td></td><td></td><td></td><td>44</td><td>43</td><td>42</td><td>41</td><td></td><td></td><td>36</td><td>34</td><td></td></tr> <tr><td></td><td></td><td>73</td><td>32</td><td></td><td></td><td>28</td><td>26</td><td></td><td></td><td></td><td></td><td>19</td><td>18</td><td></td></tr> <tr><td></td><td></td><td></td><td>16</td><td>15</td><td></td><td>12</td><td>10</td><td></td><td></td><td></td><td></td><td>3</td><td></td><td></td></tr> </table>		70	69				63				58	56	55	54	53	52	51	49				44	43	42	41			36	34				73	32			28	26					19	18					16	15		12	10					3														
	70	69				63				58	56	55	54	53																																																																	
52	51	49				44	43	42	41			36	34																																																																		
		73	32			28	26					19	18																																																																		
			16	15		12	10					3																																																																			
AVAILABLE	NOT APPLICABLE	34566-3263	G	0	C	BLUE	<table border="1"> <tr><td>72</td><td>70</td><td></td><td></td><td>66</td><td></td><td>63</td><td>62</td><td></td><td></td><td>59</td><td>57</td><td>56</td><td>55</td><td>53</td></tr> <tr><td>52</td><td>51</td><td></td><td></td><td>46</td><td>44</td><td>42</td><td>40</td><td>39</td><td></td><td></td><td></td><td></td><td>34</td><td>33</td></tr> <tr><td></td><td></td><td>73</td><td>32</td><td>30</td><td></td><td>26</td><td>25</td><td></td><td></td><td>22</td><td>21</td><td>19</td><td>18</td><td></td></tr> <tr><td></td><td></td><td></td><td>15</td><td>14</td><td></td><td>10</td><td>9</td><td></td><td></td><td>6</td><td>5</td><td>4</td><td>3</td><td></td></tr> </table>	72	70			66		63	62			59	57	56	55	53	52	51			46	44	42	40	39					34	33			73	32	30		26	25			22	21	19	18					15	14		10	9			6	5	4	3													
72	70			66		63	62			59	57	56	55	53																																																																	
52	51			46	44	42	40	39					34	33																																																																	
		73	32	30		26	25			22	21	19	18																																																																		
			15	14		10	9			6	5	4	3																																																																		
AVAILABLE	NOT APPLICABLE	34566-3273	G	0	A	BLACK	<table border="1"> <tr><td></td><td>70</td><td>69</td><td></td><td></td><td></td><td>63</td><td></td><td></td><td></td><td>58</td><td>56</td><td>55</td><td>54</td><td>53</td></tr> <tr><td>52</td><td>51</td><td>49</td><td></td><td></td><td></td><td>44</td><td>43</td><td>42</td><td>41</td><td></td><td></td><td>36</td><td>34</td><td></td></tr> <tr><td></td><td></td><td>73</td><td>32</td><td></td><td></td><td>28</td><td>26</td><td></td><td></td><td></td><td></td><td>19</td><td>18</td><td>17</td></tr> <tr><td></td><td></td><td></td><td>16</td><td>15</td><td></td><td>12</td><td>10</td><td></td><td></td><td></td><td></td><td>3</td><td>2</td><td>1</td></tr> </table>		70	69				63				58	56	55	54	53	52	51	49				44	43	42	41			36	34				73	32			28	26					19	18	17				16	15		12	10					3	2	1												
	70	69				63				58	56	55	54	53																																																																	
52	51	49				44	43	42	41			36	34																																																																		
		73	32			28	26					19	18	17																																																																	
			16	15		12	10					3	2	1																																																																	
AVAILABLE	NOT APPLICABLE	34566-3283	G	0	C	BLUE	<table border="1"> <tr><td>72</td><td>70</td><td></td><td>67</td><td>66</td><td></td><td>63</td><td>62</td><td></td><td></td><td>59</td><td>57</td><td></td><td></td><td>53</td></tr> <tr><td>52</td><td>51</td><td></td><td></td><td>46</td><td>44</td><td>42</td><td>40</td><td>39</td><td></td><td></td><td></td><td></td><td>34</td><td>33</td></tr> <tr><td></td><td></td><td>73</td><td></td><td>30</td><td></td><td>26</td><td>25</td><td></td><td></td><td>22</td><td>21</td><td></td><td></td><td></td></tr> <tr><td></td><td></td><td></td><td>15</td><td>14</td><td></td><td>10</td><td>9</td><td></td><td></td><td>6</td><td>5</td><td>4</td><td></td><td></td></tr> </table>	72	70		67	66		63	62			59	57			53	52	51			46	44	42	40	39					34	33			73		30		26	25			22	21							15	14		10	9			6	5	4														
72	70		67	66		63	62			59	57			53																																																																	
52	51			46	44	42	40	39					34	33																																																																	
		73		30		26	25			22	21																																																																				
			15	14		10	9			6	5	4																																																																			
AVAILABLE	NOT APPLICABLE	34566-3293	G	0	B	ST GRAY	<table border="1"> <tr><td>72</td><td>71</td><td>70</td><td>68</td><td>67</td><td>66</td><td></td><td></td><td>62</td><td>61</td><td>60</td><td>59</td><td>58</td><td>57</td><td>56</td><td>55</td><td>54</td><td>53</td></tr> <tr><td>52</td><td>51</td><td>50</td><td>48</td><td>47</td><td></td><td></td><td></td><td>42</td><td>41</td><td>40</td><td>39</td><td>38</td><td>37</td><td>36</td><td>35</td><td>34</td><td>33</td></tr> <tr><td></td><td></td><td>73</td><td>32</td><td>31</td><td>30</td><td>29</td><td>28</td><td>27</td><td>26</td><td>25</td><td>24</td><td>23</td><td></td><td></td><td></td><td></td><td></td></tr> <tr><td></td><td></td><td></td><td>16</td><td>15</td><td>14</td><td>13</td><td></td><td></td><td>10</td><td>9</td><td>8</td><td></td><td></td><td></td><td></td><td></td><td></td></tr> </table>	72	71	70	68	67	66			62	61	60	59	58	57	56	55	54	53	52	51	50	48	47				42	41	40	39	38	37	36	35	34	33			73	32	31	30	29	28	27	26	25	24	23									16	15	14	13			10	9	8						
72	71	70	68	67	66			62	61	60	59	58	57	56	55	54	53																																																														
52	51	50	48	47				42	41	40	39	38	37	36	35	34	33																																																														
		73	32	31	30	29	28	27	26	25	24	23																																																																			
			16	15	14	13			10	9	8																																																																				
AVAILABLE	NOT APPLICABLE	34566-3313	G	0	C	BLUE	<table border="1"> <tr><td>72</td><td>70</td><td></td><td></td><td></td><td></td><td>63</td><td>62</td><td></td><td></td><td>59</td><td>57</td><td></td><td></td><td>53</td></tr> <tr><td>52</td><td>51</td><td></td><td></td><td>46</td><td>44</td><td>42</td><td>40</td><td>39</td><td></td><td></td><td></td><td></td><td>34</td><td>33</td></tr> <tr><td></td><td></td><td>73</td><td>32</td><td>30</td><td></td><td>26</td><td>25</td><td></td><td></td><td>22</td><td>21</td><td></td><td></td><td></td></tr> <tr><td></td><td></td><td></td><td>15</td><td>14</td><td></td><td></td><td></td><td></td><td></td><td>6</td><td>5</td><td>4</td><td></td><td></td></tr> </table>	72	70					63	62			59	57			53	52	51			46	44	42	40	39					34	33			73	32	30		26	25			22	21							15	14						6	5	4														
72	70					63	62			59	57			53																																																																	
52	51			46	44	42	40	39					34	33																																																																	
		73	32	30		26	25			22	21																																																																				
			15	14						6	5	4																																																																			
AVAILABLE	NOT APPLICABLE	34566-3323	G	0	B	ST GRAY	<table border="1"> <tr><td></td><td></td><td></td><td>68</td><td>67</td><td>66</td><td>65</td><td>64</td><td>63</td><td></td><td></td><td></td><td>58</td><td></td><td>55</td><td></td><td></td><td></td></tr> <tr><td></td><td></td><td>49</td><td>48</td><td>46</td><td>45</td><td>44</td><td>43</td><td></td><td></td><td></td><td></td><td>38</td><td></td><td></td><td></td><td></td><td></td></tr> <tr><td></td><td></td><td>73</td><td>32</td><td>30</td><td>29</td><td>28</td><td>27</td><td></td><td></td><td></td><td>22</td><td></td><td></td><td></td><td></td><td></td><td>17</td></tr> <tr><td></td><td></td><td></td><td>16</td><td></td><td></td><td></td><td></td><td>10</td><td></td><td></td><td></td><td></td><td></td><td></td><td></td><td></td><td></td></tr> </table>				68	67	66	65	64	63				58		55						49	48	46	45	44	43					38								73	32	30	29	28	27				22						17				16					10									
			68	67	66	65	64	63				58		55																																																																	
		49	48	46	45	44	43					38																																																																			
		73	32	30	29	28	27				22						17																																																														
			16					10																																																																							
AVAILABLE	NOT APPLICABLE	34566-3333	G	0	A	BLACK	<table border="1"> <tr><td>72</td><td>71</td><td>70</td><td>69</td><td>68</td><td></td><td>65</td><td>64</td><td>63</td><td>61</td><td>59</td><td>58</td><td>57</td><td>56</td><td>54</td><td></td><td></td><td></td></tr> <tr><td>52</td><td>51</td><td>50</td><td>49</td><td>47</td><td></td><td></td><td></td><td>42</td><td>41</td><td></td><td></td><td>38</td><td>37</td><td>36</td><td>34</td><td>33</td><td></td></tr> <tr><td></td><td></td><td>73</td><td>32</td><td>31</td><td>30</td><td>29</td><td>28</td><td>27</td><td>26</td><td>24</td><td>23</td><td></td><td></td><td>20</td><td>19</td><td>18</td><td>17</td></tr> <tr><td></td><td></td><td></td><td>16</td><td></td><td></td><td>13</td><td>12</td><td>11</td><td>10</td><td>9</td><td></td><td></td><td></td><td>3</td><td>2</td><td>1</td><td></td></tr> </table>	72	71	70	69	68		65	64	63	61	59	58	57	56	54				52	51	50	49	47				42	41			38	37	36	34	33				73	32	31	30	29	28	27	26	24	23			20	19	18	17				16			13	12	11	10	9				3	2	1	
72	71	70	69	68		65	64	63	61	59	58	57	56	54																																																																	
52	51	50	49	47				42	41			38	37	36	34	33																																																															
		73	32	31	30	29	28	27	26	24	23			20	19	18	17																																																														
			16			13	12	11	10	9				3	2	1																																																															

ENTER DESCRIPTION EC NO: UAU2013-0662 DRAWN BY: CHKO APPR: IKOSHY DATE: 2012/11/01 REV: 1	QUALITY SYMBOLS	GENERAL TOLERANCES (UNLESS SPECIFIED)	DIMENSION STYLE	SCALE	DESIGN UNITS	THIRD ANGLE PROJECTION	
	$\nabla=0$ $\nabla=0$ $\nabla=0$	4 PLACES #--- #--- 3 PLACES #--- #--- 2 PLACES #--- #--- 1 PLACE #--- #--- 0 PLACE #--- #---	mm INCH ± ± ± ± ± ± ± ± ± ±	MM ONLY		METRIC	
				DRAWN BY: SKRA JENDRANA	DATE: 2011/02/14	TITLE: MX123 66/73/80CKT HRNS CONN ASSY	
				CHECKED BY: MVANSLAMBROU	DATE: 2011/02/14	APPROVED BY: [Signature]	
			MATERIAL NO. SEE BOM TABLE		DOCUMENT NO. SD-34566-001	SHEET NO. 39 OF 59	
THIS DRAWING CONTAINS INFORMATION THAT IS PROPRIETARY TO MOLEX INCORPORATED AND SHOULD NOT BE USED WITHOUT WRITTEN PERMISSION							

STATUS	GM PART #	MATERIAL #	PART / MATERIAL REVISION	WIRE DRESS OPTION	KEY OPTION	COLOR (TPA)	NUMBERS INDICATE CAVITIES OPEN FOR CIRCUITS																																																																						
AVAILABLE	NOT APPLICABLE	34566-3343	G	0	A	BLACK	<table border="1"> <tr><td>72</td><td></td><td>69</td><td>67</td><td>66</td><td>65</td><td>63</td><td></td><td>60</td><td></td><td>57</td><td>56</td><td></td><td>53</td></tr> <tr><td></td><td></td><td>49</td><td>47</td><td></td><td>44</td><td>43</td><td>42</td><td>40</td><td></td><td>37</td><td>36</td><td>35</td><td>33</td></tr> <tr><td>73</td><td></td><td></td><td>31</td><td>30</td><td>29</td><td>28</td><td>26</td><td>24</td><td></td><td>21</td><td>20</td><td></td><td>17</td></tr> <tr><td></td><td></td><td>16</td><td>15</td><td>14</td><td>13</td><td></td><td>11</td><td>10</td><td></td><td></td><td>5</td><td>4</td><td>3</td><td>2</td><td>1</td></tr> </table>	72		69	67	66	65	63		60		57	56		53			49	47		44	43	42	40		37	36	35	33	73			31	30	29	28	26	24		21	20		17			16	15	14	13		11	10			5	4	3	2	1												
72		69	67	66	65	63		60		57	56		53																																																																
		49	47		44	43	42	40		37	36	35	33																																																																
73			31	30	29	28	26	24		21	20		17																																																																
		16	15	14	13		11	10			5	4	3	2	1																																																														
AVAILABLE	NOT APPLICABLE	34566-3353	G	0	B	ST GRY	<table border="1"> <tr><td></td><td></td><td></td><td>68</td><td>67</td><td></td><td>64</td><td></td><td></td><td></td><td>59</td><td>58</td><td></td><td></td><td>54</td></tr> <tr><td></td><td></td><td></td><td></td><td>46</td><td>45</td><td></td><td></td><td></td><td></td><td>39</td><td>38</td><td></td><td></td><td></td></tr> <tr><td>73</td><td></td><td></td><td>32</td><td>30</td><td>29</td><td>28</td><td>27</td><td></td><td></td><td>23</td><td>22</td><td></td><td></td><td>17</td></tr> <tr><td></td><td></td><td></td><td></td><td></td><td></td><td>12</td><td>10</td><td></td><td>8</td><td></td><td></td><td></td><td></td><td></td><td>1</td></tr> </table>				68	67		64				59	58			54					46	45					39	38				73			32	30	29	28	27			23	22			17							12	10		8						1									
			68	67		64				59	58			54																																																															
				46	45					39	38																																																																		
73			32	30	29	28	27			23	22			17																																																															
						12	10		8						1																																																														
AVAILABLE	NOT APPLICABLE	34566-3363	G	0	A	BLACK	<table border="1"> <tr><td></td><td>71</td><td>69</td><td>68</td><td></td><td>65</td><td>64</td><td>63</td><td></td><td>61</td><td></td><td>59</td><td></td><td>57</td><td>56</td><td></td><td>54</td></tr> <tr><td>52</td><td></td><td>50</td><td>49</td><td></td><td>47</td><td></td><td></td><td>42</td><td>41</td><td>40</td><td>39</td><td>38</td><td>37</td><td>36</td><td></td><td>34</td><td>33</td></tr> <tr><td>73</td><td></td><td></td><td>32</td><td>31</td><td>30</td><td>29</td><td>28</td><td>27</td><td>26</td><td>24</td><td>23</td><td>22</td><td></td><td>20</td><td>19</td><td>18</td></tr> <tr><td></td><td></td><td></td><td>16</td><td></td><td></td><td>13</td><td>12</td><td>11</td><td>10</td><td>9</td><td></td><td></td><td></td><td></td><td></td><td></td><td>1</td></tr> </table>		71	69	68		65	64	63		61		59		57	56		54	52		50	49		47			42	41	40	39	38	37	36		34	33	73			32	31	30	29	28	27	26	24	23	22		20	19	18				16			13	12	11	10	9							1
	71	69	68		65	64	63		61		59		57	56		54																																																													
52		50	49		47			42	41	40	39	38	37	36		34	33																																																												
73			32	31	30	29	28	27	26	24	23	22		20	19	18																																																													
			16			13	12	11	10	9							1																																																												
AVAILABLE	NOT APPLICABLE	34566-3373	G	9	C	BLUE	<table border="1"> <tr><td>72</td><td>70</td><td>68</td><td>67</td><td>66</td><td></td><td>63</td><td>62</td><td></td><td>59</td><td></td><td>57</td><td>56</td><td>55</td><td></td><td>53</td></tr> <tr><td>52</td><td>51</td><td></td><td>48</td><td>47</td><td>46</td><td>44</td><td>42</td><td></td><td>40</td><td>39</td><td>38</td><td></td><td></td><td></td><td>34</td><td>33</td></tr> <tr><td>73</td><td></td><td></td><td>32</td><td>30</td><td></td><td></td><td>26</td><td>25</td><td></td><td></td><td>22</td><td>21</td><td></td><td>19</td><td>18</td></tr> <tr><td></td><td></td><td></td><td>15</td><td>14</td><td></td><td></td><td>10</td><td>9</td><td></td><td></td><td>6</td><td>5</td><td>4</td><td>3</td><td></td><td></td></tr> </table>	72	70	68	67	66		63	62		59		57	56	55		53	52	51		48	47	46	44	42		40	39	38				34	33	73			32	30			26	25			22	21		19	18				15	14			10	9			6	5	4	3						
72	70	68	67	66		63	62		59		57	56	55		53																																																														
52	51		48	47	46	44	42		40	39	38				34	33																																																													
73			32	30			26	25			22	21		19	18																																																														
			15	14			10	9			6	5	4	3																																																															
AVAILABLE	NOT APPLICABLE	34566-3383	G	0	A	BLACK	<table border="1"> <tr><td></td><td>70</td><td>69</td><td>68</td><td></td><td>65</td><td>64</td><td>63</td><td></td><td>61</td><td></td><td>59</td><td>58</td><td>57</td><td>56</td><td></td><td>54</td></tr> <tr><td>52</td><td></td><td>50</td><td>49</td><td>48</td><td>47</td><td></td><td></td><td>42</td><td>41</td><td></td><td></td><td>38</td><td>37</td><td>36</td><td></td><td>34</td><td>33</td></tr> <tr><td>73</td><td></td><td></td><td>32</td><td>31</td><td>30</td><td>29</td><td>28</td><td>27</td><td>26</td><td></td><td>24</td><td>23</td><td></td><td>20</td><td>19</td><td>18</td></tr> <tr><td></td><td></td><td></td><td>16</td><td></td><td></td><td>13</td><td>12</td><td>11</td><td>10</td><td>9</td><td></td><td></td><td></td><td></td><td></td><td></td><td>1</td></tr> </table>		70	69	68		65	64	63		61		59	58	57	56		54	52		50	49	48	47			42	41			38	37	36		34	33	73			32	31	30	29	28	27	26		24	23		20	19	18				16			13	12	11	10	9							1
	70	69	68		65	64	63		61		59	58	57	56		54																																																													
52		50	49	48	47			42	41			38	37	36		34	33																																																												
73			32	31	30	29	28	27	26		24	23		20	19	18																																																													
			16			13	12	11	10	9							1																																																												
AVAILABLE	NOT APPLICABLE	34566-3393	G	0	C	BLUE	<table border="1"> <tr><td>72</td><td>70</td><td>68</td><td>67</td><td>66</td><td></td><td>63</td><td>62</td><td></td><td>59</td><td></td><td>57</td><td></td><td></td><td></td><td>53</td></tr> <tr><td>52</td><td>51</td><td></td><td>48</td><td>47</td><td>46</td><td>44</td><td>42</td><td></td><td>40</td><td>39</td><td></td><td></td><td></td><td></td><td>34</td><td>33</td></tr> <tr><td>73</td><td></td><td></td><td>32</td><td>30</td><td></td><td></td><td>26</td><td>25</td><td></td><td></td><td>22</td><td>21</td><td></td><td></td><td></td><td></td></tr> <tr><td></td><td></td><td></td><td>15</td><td>14</td><td></td><td></td><td>10</td><td>9</td><td></td><td></td><td>6</td><td>5</td><td>4</td><td></td><td></td><td></td></tr> </table>	72	70	68	67	66		63	62		59		57				53	52	51		48	47	46	44	42		40	39					34	33	73			32	30			26	25			22	21								15	14			10	9			6	5	4						
72	70	68	67	66		63	62		59		57				53																																																														
52	51		48	47	46	44	42		40	39					34	33																																																													
73			32	30			26	25			22	21																																																																	
			15	14			10	9			6	5	4																																																																
AVAILABLE	NOT APPLICABLE	34566-3413	G	0	A	BLACK	<table border="1"> <tr><td>72</td><td>70</td><td></td><td>67</td><td>66</td><td>65</td><td></td><td></td><td>61</td><td></td><td></td><td>58</td><td>57</td><td></td><td>55</td><td>54</td><td></td></tr> <tr><td></td><td>50</td><td>49</td><td>47</td><td>47</td><td>45</td><td>44</td><td>43</td><td>42</td><td>41</td><td>39</td><td></td><td>37</td><td>35</td><td></td><td></td><td></td></tr> <tr><td>73</td><td></td><td></td><td>32</td><td>30</td><td></td><td></td><td>27</td><td>26</td><td>25</td><td>24</td><td></td><td>21</td><td>20</td><td>19</td><td>18</td><td>17</td></tr> <tr><td></td><td></td><td></td><td>16</td><td>15</td><td>13</td><td></td><td>11</td><td>10</td><td>9</td><td>8</td><td></td><td>6</td><td>5</td><td>3</td><td>2</td><td>1</td></tr> </table>	72	70		67	66	65			61			58	57		55	54			50	49	47	47	45	44	43	42	41	39		37	35				73			32	30			27	26	25	24		21	20	19	18	17				16	15	13		11	10	9	8		6	5	3	2	1		
72	70		67	66	65			61			58	57		55	54																																																														
	50	49	47	47	45	44	43	42	41	39		37	35																																																																
73			32	30			27	26	25	24		21	20	19	18	17																																																													
			16	15	13		11	10	9	8		6	5	3	2	1																																																													
AVAILABLE	NOT APPLICABLE	34566-3423	G	9	C	BLUE	<table border="1"> <tr><td></td><td></td><td>69</td><td></td><td></td><td></td><td>63</td><td></td><td></td><td></td><td></td><td>58</td><td>56</td><td>55</td><td>54</td><td>53</td></tr> <tr><td>52</td><td>51</td><td>49</td><td></td><td></td><td></td><td>44</td><td>43</td><td>42</td><td>41</td><td></td><td></td><td>36</td><td>35</td><td>34</td><td>33</td></tr> <tr><td>73</td><td></td><td></td><td></td><td></td><td></td><td>28</td><td>26</td><td></td><td></td><td></td><td></td><td></td><td></td><td>19</td><td>18</td><td>17</td></tr> <tr><td></td><td></td><td></td><td></td><td></td><td></td><td>12</td><td>10</td><td></td><td></td><td></td><td></td><td></td><td></td><td>3</td><td>2</td><td>1</td></tr> </table>			69				63					58	56	55	54	53	52	51	49				44	43	42	41			36	35	34	33	73						28	26							19	18	17							12	10							3	2	1				
		69				63					58	56	55	54	53																																																														
52	51	49				44	43	42	41			36	35	34	33																																																														
73						28	26							19	18	17																																																													
						12	10							3	2	1																																																													

ENTER DESCRIPTION ELEC NO: UAU2013-0662 DRAWN BY: 2012/11/01 CHKD: APPR: WJOSH 2012/11/21 REV:	QUALITY SYMBOLS	GENERAL TOLERANCES (UNLESS SPECIFIED)	DIMENSION STYLE	SCALE	DESIGN UNITS	THIRD ANGLE PROJECTION
	▽=0	4 PLACES ± mm / INCH	MM ONLY		METRIC	
	▽=0	3 PLACES ± mm / INCH				
	▽=0	2 PLACES ± mm / INCH				
	1 PLACE ± mm / INCH					
	0 PLACE ± mm / INCH					
	ANGULAR ± mm / INCH					
	DRAFT WHERE APPLICABLE MUST REMAIN WITHIN DIMENSIONS					
			DRAWN BY: SKRAJENDRANA 2011/02/14	DATE:	TITLE:	
			CHECKED BY: MYANSLAMBROU 2011/02/14	DATE:		
			APPROVED BY:	DATE:		
			MATERIAL NO.:	DOCUMENT NO.:		
			SEE BOM TABLE	SD-34566-001		
			THIS DRAWING CONTAINS INFORMATION THAT IS PROPRIETARY TO MOLEX INCORPORATED AND SHOULD NOT BE USED WITHOUT WRITTEN PERMISSION			
					SHEET NO. 40 OF 59	

STATUS	GM PART #	MATERIAL #	PART/MATERIAL REVISION	WIRE DRESS OPTION	KEY OPTION	COLOR (TPA)	NUMBERS INDICATE CAVITIES OPEN FOR CIRCUITS																																																																																
AVAILABLE	NOT APPLICABLE	34566-3433	G	9	C	BLUE	<table border="1"> <tr><td>72</td><td>70</td><td></td><td></td><td>66</td><td></td><td>63</td><td>62</td><td></td><td></td><td>59</td><td></td><td>57</td><td>56</td><td>55</td><td>53</td></tr> <tr><td>52</td><td>51</td><td></td><td></td><td>46</td><td>44</td><td>42</td><td>40</td><td>39</td><td></td><td>22</td><td>21</td><td></td><td></td><td>34</td><td>33</td></tr> <tr><td></td><td></td><td>73</td><td></td><td>30</td><td></td><td>26</td><td>25</td><td></td><td></td><td>6</td><td></td><td></td><td></td><td></td><td></td></tr> <tr><td></td><td></td><td></td><td></td><td>15</td><td>14</td><td></td><td>10</td><td>9</td><td></td><td></td><td></td><td></td><td></td><td></td><td></td></tr> </table>	72	70			66		63	62			59		57	56	55	53	52	51			46	44	42	40	39		22	21			34	33			73		30		26	25			6										15	14		10	9																							
72	70			66		63	62			59		57	56	55	53																																																																								
52	51			46	44	42	40	39		22	21			34	33																																																																								
		73		30		26	25			6																																																																													
				15	14		10	9																																																																															
AVAILABLE	NOT APPLICABLE	34566-3443	G	0	A	BLACK	<table border="1"> <tr><td></td><td>71</td><td>69</td><td></td><td></td><td>65</td><td>64</td><td>63</td><td></td><td>60</td><td></td><td></td><td>57</td><td>56</td><td>55</td><td>54</td><td>53</td></tr> <tr><td>52</td><td>51</td><td>49</td><td></td><td></td><td>45</td><td>44</td><td>43</td><td>42</td><td>41</td><td></td><td>23</td><td></td><td></td><td>19</td><td>18</td><td></td></tr> <tr><td></td><td></td><td></td><td>73</td><td></td><td>32</td><td>30</td><td>28</td><td>26</td><td></td><td></td><td></td><td></td><td></td><td>3</td><td></td><td></td></tr> <tr><td></td><td></td><td></td><td></td><td></td><td>16</td><td></td><td>12</td><td>10</td><td></td><td></td><td></td><td></td><td></td><td></td><td></td><td></td></tr> </table>		71	69			65	64	63		60			57	56	55	54	53	52	51	49			45	44	43	42	41		23			19	18					73		32	30	28	26						3								16		12	10																				
	71	69			65	64	63		60			57	56	55	54	53																																																																							
52	51	49			45	44	43	42	41		23			19	18																																																																								
			73		32	30	28	26						3																																																																									
					16		12	10																																																																															
AVAILABLE	NOT APPLICABLE	34566-3453	G	0	A	BLACK	<table border="1"> <tr><td></td><td></td><td></td><td></td><td></td><td></td><td></td><td></td><td></td><td></td><td>61</td><td></td><td></td><td></td><td></td><td></td><td></td></tr> <tr><td></td><td></td><td></td><td></td><td></td><td></td><td></td><td></td><td></td><td></td><td></td><td></td><td></td><td></td><td></td><td>20</td><td></td></tr> <tr><td></td><td></td><td></td><td>73</td><td></td><td></td><td></td><td></td><td></td><td></td><td></td><td>9</td><td></td><td></td><td>5</td><td></td><td>1</td></tr> </table>											61																						20					73								9			5		1																													
										61																																																																													
															20																																																																								
			73								9			5		1																																																																							
AVAILABLE	NOT APPLICABLE	34566-3463	G	9	H	ST GRY	<table border="1"> <tr><td></td><td></td><td></td><td></td><td></td><td></td><td></td><td></td><td></td><td></td><td></td><td></td><td></td><td></td><td></td><td></td><td>61</td></tr> <tr><td></td><td></td><td></td><td></td><td></td><td></td><td></td><td></td><td></td><td></td><td></td><td></td><td></td><td></td><td></td><td></td><td></td></tr> <tr><td>20</td><td></td><td></td><td></td><td></td><td></td><td></td><td></td><td></td><td></td><td>9</td><td></td><td></td><td>5</td><td></td><td></td><td>1</td></tr> </table>																	61																		20										9			5			1																													
																61																																																																							
20										9			5			1																																																																							
AVAILABLE	NOT APPLICABLE	34566-3473	G	9	B	ST GRY	<table border="1"> <tr><td>72</td><td>71</td><td>70</td><td>69</td><td>68</td><td>67</td><td>66</td><td>65</td><td>64</td><td></td><td>62</td><td>61</td><td>60</td><td>59</td><td>58</td><td>57</td><td>56</td><td>55</td><td>54</td></tr> <tr><td>52</td><td>51</td><td>50</td><td>49</td><td></td><td>46</td><td>44</td><td></td><td></td><td></td><td></td><td>40</td><td>38</td><td>37</td><td>36</td><td></td><td></td><td></td><td></td></tr> <tr><td></td><td></td><td></td><td></td><td>73</td><td></td><td>32</td><td>31</td><td>30</td><td>29</td><td>28</td><td>27</td><td>25</td><td>24</td><td></td><td>21</td><td>20</td><td>18</td><td>17</td></tr> <tr><td></td><td></td><td></td><td></td><td></td><td></td><td>16</td><td>15</td><td>14</td><td>13</td><td>12</td><td>10</td><td>9</td><td>7</td><td>6</td><td>5</td><td>4</td><td>3</td><td>2</td></tr> </table>	72	71	70	69	68	67	66	65	64		62	61	60	59	58	57	56	55	54	52	51	50	49		46	44					40	38	37	36									73		32	31	30	29	28	27	25	24		21	20	18	17							16	15	14	13	12	10	9	7	6	5	4	3	2				
72	71	70	69	68	67	66	65	64		62	61	60	59	58	57	56	55	54																																																																					
52	51	50	49		46	44					40	38	37	36																																																																									
				73		32	31	30	29	28	27	25	24		21	20	18	17																																																																					
						16	15	14	13	12	10	9	7	6	5	4	3	2																																																																					
AVAILABLE	NOT APPLICABLE	34566-3483	G	0	B	ST GRY	<table border="1"> <tr><td>72</td><td>71</td><td>70</td><td>69</td><td>68</td><td>67</td><td>66</td><td>65</td><td></td><td></td><td>61</td><td>60</td><td></td><td></td><td>57</td><td>56</td><td>55</td><td>54</td></tr> <tr><td>52</td><td>51</td><td>50</td><td>49</td><td>48</td><td>46</td><td>44</td><td></td><td></td><td></td><td>40</td><td>38</td><td>37</td><td>36</td><td></td><td></td><td></td><td></td></tr> <tr><td></td><td></td><td></td><td></td><td>73</td><td></td><td>32</td><td>31</td><td>30</td><td>29</td><td>28</td><td>27</td><td>24</td><td></td><td>21</td><td>20</td><td>19</td><td>18</td><td>17</td></tr> <tr><td></td><td></td><td></td><td></td><td></td><td></td><td>16</td><td>15</td><td>14</td><td>13</td><td>12</td><td>11</td><td>10</td><td>9</td><td>7</td><td>6</td><td>5</td><td>4</td><td>2</td></tr> </table>	72	71	70	69	68	67	66	65			61	60			57	56	55	54	52	51	50	49	48	46	44				40	38	37	36									73		32	31	30	29	28	27	24		21	20	19	18	17							16	15	14	13	12	11	10	9	7	6	5	4	2						
72	71	70	69	68	67	66	65			61	60			57	56	55	54																																																																						
52	51	50	49	48	46	44				40	38	37	36																																																																										
				73		32	31	30	29	28	27	24		21	20	19	18	17																																																																					
						16	15	14	13	12	11	10	9	7	6	5	4	2																																																																					
AVAILABLE	NOT APPLICABLE	34566-3493	G	0	A	BLACK	<table border="1"> <tr><td>72</td><td>70</td><td></td><td></td><td>67</td><td>66</td><td>65</td><td></td><td></td><td></td><td>61</td><td></td><td></td><td>58</td><td>57</td><td></td><td>55</td><td>54</td></tr> <tr><td></td><td></td><td>49</td><td></td><td>47</td><td>45</td><td>44</td><td>43</td><td>42</td><td>41</td><td></td><td>39</td><td></td><td>37</td><td></td><td>35</td><td></td><td></td></tr> <tr><td></td><td></td><td></td><td>73</td><td></td><td>32</td><td></td><td>30</td><td></td><td>27</td><td>26</td><td>25</td><td>24</td><td></td><td>21</td><td>20</td><td>19</td><td>18</td><td>17</td></tr> <tr><td></td><td></td><td></td><td></td><td></td><td>16</td><td>15</td><td>13</td><td></td><td>11</td><td>10</td><td>9</td><td>8</td><td></td><td>6</td><td>5</td><td>3</td><td>2</td><td>1</td></tr> </table>	72	70			67	66	65				61			58	57		55	54			49		47	45	44	43	42	41		39		37		35						73		32		30		27	26	25	24		21	20	19	18	17						16	15	13		11	10	9	8		6	5	3	2	1						
72	70			67	66	65				61			58	57		55	54																																																																						
		49		47	45	44	43	42	41		39		37		35																																																																								
			73		32		30		27	26	25	24		21	20	19	18	17																																																																					
					16	15	13		11	10	9	8		6	5	3	2	1																																																																					
AVAILABLE	NOT APPLICABLE	34566-3513	G	0	A	BLACK	<table border="1"> <tr><td></td><td>70</td><td>69</td><td></td><td></td><td></td><td></td><td></td><td>63</td><td>62</td><td>61</td><td>60</td><td></td><td></td><td>58</td><td>57</td><td>56</td><td>55</td><td>54</td><td>53</td></tr> <tr><td>52</td><td>51</td><td>49</td><td></td><td></td><td></td><td></td><td></td><td>44</td><td>43</td><td>42</td><td>41</td><td></td><td></td><td></td><td>37</td><td>36</td><td>34</td><td></td><td></td></tr> <tr><td></td><td></td><td></td><td>73</td><td></td><td></td><td></td><td></td><td>29</td><td>28</td><td>27</td><td>26</td><td></td><td></td><td></td><td></td><td></td><td>19</td><td>18</td><td></td></tr> <tr><td></td><td></td><td></td><td></td><td></td><td></td><td></td><td></td><td>16</td><td>15</td><td>13</td><td>12</td><td>11</td><td>10</td><td></td><td></td><td></td><td>3</td><td></td><td></td></tr> </table>		70	69						63	62	61	60			58	57	56	55	54	53	52	51	49						44	43	42	41				37	36	34						73					29	28	27	26						19	18										16	15	13	12	11	10				3		
	70	69						63	62	61	60			58	57	56	55	54	53																																																																				
52	51	49						44	43	42	41				37	36	34																																																																						
			73					29	28	27	26						19	18																																																																					
								16	15	13	12	11	10				3																																																																						

ENTER DESCRIPTION EC NO: UAU2013-0662 DRAWN BY: 2012/11/01 CHKD: APPR: IKOSHY 2012/11/21 REV: 1/06	QUALITY SYMBOLS	GENERAL TOLERANCES (UNLESS SPECIFIED)	DIMENSION STYLE	SCALE	DESIGN UNITS	THIRD ANGLE PROJECTION
	▽=0	mm INCH	MM ONLY		METRIC	
	▽=0	4 PLACES #---#	DRAWN BY: SKRAJENDRANA 2011/02/14	DATE: 2011/02/14	TITLE: MX123 66/73/80CKT HRNS CONN ASSY	
	▽=0	3 PLACES #---#	CHECKED BY: MVANSLAMBROU 2011/02/14	DATE: 2011/02/14	APPROVED BY: DATE: _____	
	ANGULAR ±---°	DRAFT WHERE APPLICABLE MUST REMAIN WITHIN DIMENSIONS	SEE BOM TABLE	MATERIAL NO. SD-34566-001	DOCUMENT NO. SD-34566-001	SHEET NO. 41 OF 59
			THIS DRAWING CONTAINS INFORMATION THAT IS PROPRIETARY TO MOLEX INCORPORATED AND SHOULD NOT BE USED WITHOUT WRITTEN PERMISSION			

STATUS	GM PART #	MATERIAL #	PART/MATERIAL REVISION	WIRE DRESS OPTION	KEY OPTION	COLOR (TPA)	NUMBERS INDICATE CAVITIES OPEN FOR CIRCUITS																																																																											
SALEABLE	NOT APPLICABLE	34566-3523	G	0	A	BLACK	<table border="1"> <tr><td>72</td><td>70</td><td></td><td></td><td>66</td><td></td><td>63</td><td>62</td><td></td><td></td><td></td><td></td><td>56</td><td>55</td><td>54</td></tr> <tr><td>52</td><td></td><td>49</td><td></td><td></td><td></td><td>43</td><td>42</td><td></td><td></td><td></td><td></td><td>36</td><td>35</td><td>34</td></tr> <tr><td></td><td></td><td></td><td>73</td><td></td><td>31</td><td></td><td>28</td><td>26</td><td></td><td></td><td></td><td>21</td><td>20</td><td>19</td></tr> <tr><td></td><td></td><td></td><td></td><td>16</td><td>15</td><td></td><td>12</td><td>10</td><td>9</td><td></td><td></td><td>5</td><td></td><td>2</td></tr> <tr><td></td><td></td><td></td><td></td><td></td><td></td><td></td><td></td><td></td><td></td><td></td><td></td><td></td><td></td><td>1</td></tr> </table>	72	70			66		63	62					56	55	54	52		49				43	42					36	35	34				73		31		28	26				21	20	19					16	15		12	10	9			5		2															1
72	70			66		63	62					56	55	54																																																																				
52		49				43	42					36	35	34																																																																				
			73		31		28	26				21	20	19																																																																				
				16	15		12	10	9			5		2																																																																				
														1																																																																				
SALEABLE	NOT APPLICABLE	34566-3533	G	9	A	BLACK	<table border="1"> <tr><td></td><td></td><td>69</td><td></td><td></td><td></td><td>63</td><td></td><td></td><td></td><td></td><td>58</td><td>56</td><td>55</td><td>54</td><td>53</td></tr> <tr><td>52</td><td>51</td><td>49</td><td></td><td></td><td></td><td>44</td><td>43</td><td>42</td><td>41</td><td></td><td></td><td>36</td><td>35</td><td>34</td><td>33</td></tr> <tr><td></td><td></td><td></td><td>73</td><td></td><td>32</td><td></td><td>28</td><td>26</td><td></td><td></td><td></td><td></td><td>19</td><td>18</td><td>17</td></tr> <tr><td></td><td></td><td></td><td></td><td>16</td><td></td><td></td><td>12</td><td>10</td><td></td><td></td><td></td><td></td><td>3</td><td>2</td><td>1</td></tr> </table>			69				63					58	56	55	54	53	52	51	49				44	43	42	41			36	35	34	33				73		32		28	26					19	18	17					16			12	10					3	2	1											
		69				63					58	56	55	54	53																																																																			
52	51	49				44	43	42	41			36	35	34	33																																																																			
			73		32		28	26					19	18	17																																																																			
				16			12	10					3	2	1																																																																			
AVAILABLE	NOT APPLICABLE	34566-3543	G	9	A	BLACK	<table border="1"> <tr><td>72</td><td>70</td><td></td><td></td><td>66</td><td></td><td>63</td><td>62</td><td></td><td></td><td></td><td>59</td><td>57</td><td>56</td><td>55</td><td>53</td></tr> <tr><td>52</td><td>51</td><td></td><td></td><td>46</td><td>44</td><td>42</td><td>40</td><td>39</td><td></td><td></td><td></td><td></td><td></td><td></td><td>34</td></tr> <tr><td></td><td></td><td></td><td>73</td><td></td><td>30</td><td></td><td>26</td><td>25</td><td></td><td></td><td>22</td><td>21</td><td></td><td></td><td></td></tr> <tr><td></td><td></td><td></td><td></td><td>15</td><td>14</td><td></td><td>10</td><td>9</td><td></td><td></td><td>6</td><td></td><td></td><td></td><td></td></tr> </table>	72	70			66		63	62				59	57	56	55	53	52	51			46	44	42	40	39							34				73		30		26	25			22	21								15	14		10	9			6															
72	70			66		63	62				59	57	56	55	53																																																																			
52	51			46	44	42	40	39							34																																																																			
			73		30		26	25			22	21																																																																						
				15	14		10	9			6																																																																							
AVAILABLE	NOT APPLICABLE	34566-3553	G	9	C	BLUE	<table border="1"> <tr><td>72</td><td>71</td><td>70</td><td>69</td><td>68</td><td>67</td><td>66</td><td>65</td><td>63</td><td>62</td><td>61</td><td>59</td><td>58</td><td>57</td><td>56</td><td>55</td><td>54</td><td>53</td></tr> <tr><td>52</td><td>51</td><td>50</td><td>49</td><td>48</td><td>46</td><td>45</td><td>44</td><td>43</td><td>42</td><td>41</td><td>40</td><td>39</td><td>38</td><td>36</td><td>35</td><td>34</td><td>33</td></tr> <tr><td></td><td></td><td></td><td>73</td><td></td><td>31</td><td>30</td><td>29</td><td>28</td><td>27</td><td>26</td><td>25</td><td>22</td><td>20</td><td>19</td><td>18</td><td>17</td><td></td></tr> <tr><td></td><td></td><td></td><td></td><td>16</td><td>15</td><td>14</td><td></td><td></td><td>11</td><td>10</td><td>9</td><td>7</td><td>6</td><td>5</td><td>3</td><td>2</td><td>1</td></tr> </table>	72	71	70	69	68	67	66	65	63	62	61	59	58	57	56	55	54	53	52	51	50	49	48	46	45	44	43	42	41	40	39	38	36	35	34	33				73		31	30	29	28	27	26	25	22	20	19	18	17						16	15	14			11	10	9	7	6	5	3	2	1			
72	71	70	69	68	67	66	65	63	62	61	59	58	57	56	55	54	53																																																																	
52	51	50	49	48	46	45	44	43	42	41	40	39	38	36	35	34	33																																																																	
			73		31	30	29	28	27	26	25	22	20	19	18	17																																																																		
				16	15	14			11	10	9	7	6	5	3	2	1																																																																	
AVAILABLE	NOT APPLICABLE	34566-3563	G	9	C	BLUE	<table border="1"> <tr><td>72</td><td>70</td><td></td><td></td><td>68</td><td>67</td><td>66</td><td></td><td>63</td><td>62</td><td></td><td>59</td><td>57</td><td></td><td></td><td></td><td>53</td></tr> <tr><td>52</td><td>51</td><td></td><td></td><td>48</td><td>47</td><td>46</td><td>44</td><td>42</td><td>40</td><td>39</td><td>38</td><td></td><td></td><td></td><td></td><td>34</td></tr> <tr><td></td><td></td><td></td><td>73</td><td></td><td>32</td><td>30</td><td></td><td>27</td><td>26</td><td>25</td><td></td><td>22</td><td>21</td><td></td><td></td><td></td></tr> <tr><td></td><td></td><td></td><td></td><td>15</td><td>14</td><td></td><td></td><td>10</td><td>9</td><td></td><td>6</td><td>5</td><td>4</td><td></td><td></td><td></td></tr> </table>	72	70			68	67	66		63	62		59	57				53	52	51			48	47	46	44	42	40	39	38					34				73		32	30		27	26	25		22	21								15	14			10	9		6	5	4										
72	70			68	67	66		63	62		59	57				53																																																																		
52	51			48	47	46	44	42	40	39	38					34																																																																		
			73		32	30		27	26	25		22	21																																																																					
				15	14			10	9		6	5	4																																																																					
AVAILABLE	NOT APPLICABLE	34566-3573	G	9	C	BLUE	<table border="1"> <tr><td></td><td>70</td><td>69</td><td>68</td><td></td><td></td><td></td><td></td><td>63</td><td>62</td><td>61</td><td></td><td>58</td><td>57</td><td>56</td><td>55</td><td>54</td><td>53</td></tr> <tr><td>52</td><td>51</td><td>50</td><td>49</td><td>48</td><td>47</td><td></td><td></td><td>44</td><td>43</td><td>42</td><td>41</td><td></td><td></td><td>37</td><td>36</td><td>34</td><td></td></tr> <tr><td></td><td></td><td></td><td>73</td><td></td><td>32</td><td></td><td>29</td><td>28</td><td>27</td><td>26</td><td></td><td></td><td></td><td></td><td>19</td><td>18</td><td></td></tr> <tr><td></td><td></td><td></td><td></td><td>16</td><td>15</td><td>14</td><td>13</td><td>12</td><td>11</td><td>10</td><td></td><td></td><td></td><td></td><td>3</td><td></td><td></td></tr> </table>		70	69	68					63	62	61		58	57	56	55	54	53	52	51	50	49	48	47			44	43	42	41			37	36	34					73		32		29	28	27	26					19	18						16	15	14	13	12	11	10					3					
	70	69	68					63	62	61		58	57	56	55	54	53																																																																	
52	51	50	49	48	47			44	43	42	41			37	36	34																																																																		
			73		32		29	28	27	26					19	18																																																																		
				16	15	14	13	12	11	10					3																																																																			
AVAILABLE	NOT APPLICABLE	34566-3583	G	9	A	BLACK	<table border="1"> <tr><td></td><td>70</td><td>69</td><td></td><td></td><td></td><td></td><td></td><td>63</td><td>62</td><td>61</td><td></td><td>58</td><td>57</td><td>56</td><td>55</td><td>54</td><td>53</td></tr> <tr><td>52</td><td>51</td><td>50</td><td>49</td><td></td><td></td><td></td><td></td><td>44</td><td>43</td><td>42</td><td>41</td><td></td><td></td><td>37</td><td>36</td><td>34</td><td></td></tr> <tr><td></td><td></td><td></td><td>73</td><td></td><td>32</td><td></td><td>29</td><td>28</td><td>27</td><td>26</td><td></td><td></td><td></td><td></td><td>19</td><td>18</td><td></td></tr> <tr><td></td><td></td><td></td><td></td><td>16</td><td>15</td><td>14</td><td>13</td><td>12</td><td>11</td><td>10</td><td></td><td></td><td></td><td></td><td>3</td><td></td><td></td></tr> </table>		70	69						63	62	61		58	57	56	55	54	53	52	51	50	49					44	43	42	41			37	36	34					73		32		29	28	27	26					19	18						16	15	14	13	12	11	10					3					
	70	69						63	62	61		58	57	56	55	54	53																																																																	
52	51	50	49					44	43	42	41			37	36	34																																																																		
			73		32		29	28	27	26					19	18																																																																		
				16	15	14	13	12	11	10					3																																																																			
AVAILABLE	NOT APPLICABLE	34566-3593	G	0	A	BLACK	<table border="1"> <tr><td></td><td>71</td><td>69</td><td></td><td></td><td></td><td></td><td></td><td>64</td><td>63</td><td></td><td>60</td><td>58</td><td>57</td><td>56</td><td>55</td><td>54</td><td>53</td></tr> <tr><td>52</td><td>51</td><td>49</td><td></td><td></td><td></td><td></td><td></td><td>45</td><td>44</td><td>43</td><td>42</td><td>41</td><td></td><td></td><td>37</td><td>36</td><td>35</td></tr> <tr><td></td><td></td><td></td><td>73</td><td></td><td>32</td><td>30</td><td>28</td><td>27</td><td>26</td><td></td><td></td><td></td><td></td><td></td><td>19</td><td>18</td><td></td></tr> <tr><td></td><td></td><td></td><td></td><td>16</td><td>15</td><td></td><td>12</td><td>10</td><td></td><td></td><td></td><td></td><td></td><td></td><td>3</td><td></td><td></td></tr> </table>		71	69						64	63		60	58	57	56	55	54	53	52	51	49						45	44	43	42	41			37	36	35				73		32	30	28	27	26						19	18						16	15		12	10							3					
	71	69						64	63		60	58	57	56	55	54	53																																																																	
52	51	49						45	44	43	42	41			37	36	35																																																																	
			73		32	30	28	27	26						19	18																																																																		
				16	15		12	10							3																																																																			
AVAILABLE	NOT APPLICABLE	34566-3613	G	0	B	ST GRAY	<table border="1"> <tr><td></td><td></td><td></td><td></td><td>68</td><td>67</td><td></td><td></td><td>64</td><td>63</td><td></td><td></td><td>59</td><td></td><td></td><td></td><td></td><td></td></tr> <tr><td></td><td></td><td></td><td></td><td>46</td><td>45</td><td></td><td></td><td>43</td><td></td><td></td><td></td><td>39</td><td></td><td></td><td></td><td></td><td></td></tr> <tr><td></td><td></td><td></td><td>73</td><td></td><td>32</td><td>30</td><td>29</td><td>28</td><td>27</td><td></td><td></td><td></td><td></td><td></td><td></td><td></td><td></td></tr> <tr><td></td><td></td><td></td><td></td><td></td><td></td><td></td><td></td><td></td><td>10</td><td></td><td></td><td>6</td><td>5</td><td>4</td><td>3</td><td></td><td></td></tr> </table>					68	67			64	63			59										46	45			43				39									73		32	30	29	28	27																		10			6	5	4	3					
				68	67			64	63			59																																																																						
				46	45			43				39																																																																						
			73		32	30	29	28	27																																																																									
									10			6	5	4	3																																																																			

ENTER DESCRIPTION EC NO: UAU2013-0662 DRAWN BY: 2012/11/06 CHKD: 2012/11/21 APPR: IKOSHY REV: DESCRIPTION	QUALITY SYMBOLS	GENERAL TOLERANCES (UNLESS SPECIFIED)	DIMENSION STYLE	SCALE	DESIGN UNITS	THIRD ANGLE PROJECTION
	∇=0 ∇=0 ∇=0	mm INCH 4 PLACES ± --- ± --- 3 PLACES ± --- ± --- 2 PLACES ± --- ± --- 1 PLACE ± --- ± --- 0 PLACE ± --- ± ---	MM ONLY		METRIC	SKRA JENDRANA 2011/02/14 MVANSLAMBROU 2011/02/14
	ANGULAR ± --- °	DRAFT WHERE APPLICABLE MUST REMAIN WITHIN DIMENSIONS	SEE BOM TABLE			MX123 66/73/80CKT HRNS CONN ASSY molex
						MATERIAL NO. SD-34566-001 DOCUMENT NO. SD-34566-001 SHEET NO. 42 OF 59

STATUS	GM PART #	MATERIAL #	PART/MATERIAL REVISION	WIRE DRESS OPTION	KEY OPTION	COLOR (TPA)	NUMBERS INDICATE CAVITIES OPEN FOR CIRCUITS																																																																																								
AVAILABLE	NOT APPLICABLE	34566-3623	G	0	A	BLACK	<table border="1"> <tr><td>72</td><td>70</td><td>69</td><td></td><td></td><td></td><td></td><td></td><td>63</td><td>62</td><td>61</td><td>60</td><td>59</td><td>58</td><td>57</td><td>56</td><td>55</td><td>54</td><td>53</td></tr> <tr><td>52</td><td>51</td><td>49</td><td></td><td></td><td></td><td></td><td></td><td>44</td><td>43</td><td>42</td><td>41</td><td></td><td></td><td></td><td>37</td><td>36</td><td>34</td><td></td></tr> <tr><td></td><td></td><td></td><td>32</td><td></td><td></td><td></td><td></td><td>29</td><td>28</td><td>27</td><td>26</td><td></td><td></td><td></td><td></td><td></td><td>19</td><td>18</td></tr> <tr><td></td><td></td><td></td><td>16</td><td>15</td><td></td><td></td><td></td><td>13</td><td>12</td><td>11</td><td>10</td><td></td><td>8</td><td></td><td></td><td></td><td>3</td><td></td></tr> </table>	72	70	69						63	62	61	60	59	58	57	56	55	54	53	52	51	49						44	43	42	41				37	36	34					32					29	28	27	26						19	18				16	15				13	12	11	10		8				3													
72	70	69						63	62	61	60	59	58	57	56	55	54	53																																																																													
52	51	49						44	43	42	41				37	36	34																																																																														
			32					29	28	27	26						19	18																																																																													
			16	15				13	12	11	10		8				3																																																																														
AVAILABLE	NOT APPLICABLE	34566-3633	G	0	C	BLUE	<table border="1"> <tr><td>72</td><td>70</td><td>68</td><td>67</td><td>66</td><td></td><td></td><td></td><td>63</td><td>62</td><td></td><td></td><td></td><td>59</td><td>57</td><td></td><td></td><td></td><td>53</td></tr> <tr><td>52</td><td>51</td><td></td><td>48</td><td>47</td><td>46</td><td></td><td></td><td>44</td><td></td><td></td><td></td><td></td><td>40</td><td>39</td><td>38</td><td>37</td><td>36</td><td>34</td><td>33</td></tr> <tr><td></td><td></td><td></td><td>32</td><td></td><td>30</td><td></td><td></td><td></td><td></td><td></td><td></td><td></td><td>26</td><td>25</td><td>24</td><td>23</td><td>22</td><td>21</td><td></td></tr> <tr><td></td><td></td><td></td><td></td><td></td><td>15</td><td>14</td><td></td><td></td><td></td><td></td><td></td><td></td><td>10</td><td>9</td><td>8</td><td>7</td><td>6</td><td>5</td><td>4</td><td>2</td></tr> </table>	72	70	68	67	66				63	62				59	57				53	52	51		48	47	46			44					40	39	38	37	36	34	33				32		30								26	25	24	23	22	21							15	14							10	9	8	7	6	5	4	2								
72	70	68	67	66				63	62				59	57				53																																																																													
52	51		48	47	46			44					40	39	38	37	36	34	33																																																																												
			32		30								26	25	24	23	22	21																																																																													
					15	14							10	9	8	7	6	5	4	2																																																																											
AVAILABLE	NOT APPLICABLE	34566-3643	G	0	B	ST GRAY	<table border="1"> <tr><td>72</td><td>71</td><td>70</td><td>68</td><td>67</td><td>66</td><td></td><td></td><td>64</td><td>63</td><td></td><td></td><td></td><td>59</td><td></td><td></td><td></td><td></td><td></td><td>53</td></tr> <tr><td>52</td><td>51</td><td>50</td><td>48</td><td>47</td><td>46</td><td></td><td></td><td></td><td></td><td></td><td></td><td></td><td>39</td><td></td><td></td><td></td><td></td><td></td><td>34</td><td>33</td></tr> <tr><td></td><td></td><td></td><td>32</td><td>31</td><td>30</td><td>29</td><td>28</td><td>27</td><td>26</td><td>25</td><td>24</td><td></td><td></td><td></td><td></td><td></td><td></td><td></td><td>17</td><td></td></tr> <tr><td></td><td></td><td></td><td>16</td><td>15</td><td>14</td><td>13</td><td></td><td></td><td></td><td>10</td><td>8</td><td></td><td></td><td></td><td></td><td></td><td></td><td></td><td>2</td><td>1</td></tr> </table>	72	71	70	68	67	66			64	63				59						53	52	51	50	48	47	46								39						34	33				32	31	30	29	28	27	26	25	24								17					16	15	14	13				10	8								2	1					
72	71	70	68	67	66			64	63				59						53																																																																												
52	51	50	48	47	46								39						34	33																																																																											
			32	31	30	29	28	27	26	25	24								17																																																																												
			16	15	14	13				10	8								2	1																																																																											
AVAILABLE	NOT APPLICABLE	34566-3653	G	0	B	ST GRAY	<table border="1"> <tr><td>72</td><td>71</td><td>70</td><td>69</td><td>68</td><td>67</td><td>66</td><td></td><td></td><td>65</td><td>64</td><td>63</td><td></td><td></td><td>59</td><td></td><td></td><td></td><td></td><td></td><td>53</td></tr> <tr><td>52</td><td>51</td><td>50</td><td>49</td><td>48</td><td>47</td><td>46</td><td></td><td></td><td>45</td><td>44</td><td>43</td><td></td><td></td><td>39</td><td></td><td></td><td></td><td></td><td></td><td>34</td><td>33</td></tr> <tr><td></td><td></td><td></td><td>32</td><td>31</td><td>30</td><td>29</td><td>28</td><td>27</td><td>26</td><td>25</td><td>24</td><td></td><td></td><td></td><td></td><td></td><td></td><td></td><td></td><td>17</td><td></td></tr> <tr><td></td><td></td><td></td><td>16</td><td>15</td><td>14</td><td>13</td><td>12</td><td>11</td><td>10</td><td>8</td><td></td><td></td><td></td><td></td><td></td><td></td><td></td><td></td><td></td><td>3</td><td>2</td><td>1</td></tr> </table>	72	71	70	69	68	67	66			65	64	63			59						53	52	51	50	49	48	47	46			45	44	43			39						34	33				32	31	30	29	28	27	26	25	24									17					16	15	14	13	12	11	10	8										3	2	1
72	71	70	69	68	67	66			65	64	63			59						53																																																																											
52	51	50	49	48	47	46			45	44	43			39						34	33																																																																										
			32	31	30	29	28	27	26	25	24									17																																																																											
			16	15	14	13	12	11	10	8										3	2	1																																																																									
AVAILABLE	NOT APPLICABLE	34566-3663	G	0	A	BLACK	<table border="1"> <tr><td>72</td><td>70</td><td>69</td><td></td><td></td><td></td><td></td><td></td><td></td><td>63</td><td>62</td><td>61</td><td>60</td><td>59</td><td>58</td><td>57</td><td>56</td><td>55</td><td>54</td><td>53</td></tr> <tr><td>52</td><td>51</td><td>49</td><td></td><td></td><td></td><td></td><td></td><td></td><td>44</td><td>43</td><td>42</td><td>41</td><td></td><td></td><td></td><td>37</td><td>36</td><td>34</td><td></td></tr> <tr><td></td><td></td><td></td><td>32</td><td></td><td></td><td></td><td></td><td></td><td>29</td><td>28</td><td>27</td><td>26</td><td></td><td></td><td></td><td></td><td></td><td>19</td><td>18</td></tr> <tr><td></td><td></td><td></td><td>16</td><td>15</td><td></td><td></td><td></td><td></td><td>13</td><td>12</td><td>11</td><td>10</td><td></td><td>7</td><td>6</td><td></td><td></td><td>3</td><td></td></tr> </table>	72	70	69							63	62	61	60	59	58	57	56	55	54	53	52	51	49							44	43	42	41				37	36	34					32						29	28	27	26						19	18				16	15					13	12	11	10		7	6			3									
72	70	69							63	62	61	60	59	58	57	56	55	54	53																																																																												
52	51	49							44	43	42	41				37	36	34																																																																													
			32						29	28	27	26						19	18																																																																												
			16	15					13	12	11	10		7	6			3																																																																													
AVAILABLE	NOT APPLICABLE	34566-3673	G	9	C	BLUE	<table border="1"> <tr><td></td><td>71</td><td>70</td><td>69</td><td>68</td><td>67</td><td></td><td></td><td>65</td><td>63</td><td>62</td><td>61</td><td></td><td></td><td>59</td><td>58</td><td>57</td><td>56</td><td>55</td><td>54</td><td>53</td></tr> <tr><td></td><td>51</td><td>50</td><td>49</td><td>48</td><td></td><td></td><td></td><td>45</td><td>44</td><td>43</td><td>42</td><td>41</td><td>40</td><td>39</td><td>38</td><td></td><td>36</td><td>35</td><td>34</td><td>33</td></tr> <tr><td></td><td></td><td></td><td></td><td></td><td></td><td>31</td><td>30</td><td>29</td><td>28</td><td>27</td><td>26</td><td></td><td></td><td></td><td></td><td>22</td><td></td><td>20</td><td>19</td><td>18</td><td>17</td></tr> <tr><td></td><td></td><td></td><td></td><td></td><td></td><td>16</td><td>15</td><td>14</td><td></td><td></td><td></td><td></td><td></td><td>9</td><td>7</td><td>6</td><td>5</td><td></td><td>3</td><td>2</td><td>1</td></tr> </table>		71	70	69	68	67			65	63	62	61			59	58	57	56	55	54	53		51	50	49	48				45	44	43	42	41	40	39	38		36	35	34	33							31	30	29	28	27	26					22		20	19	18	17							16	15	14						9	7	6	5		3	2	1		
	71	70	69	68	67			65	63	62	61			59	58	57	56	55	54	53																																																																											
	51	50	49	48				45	44	43	42	41	40	39	38		36	35	34	33																																																																											
						31	30	29	28	27	26					22		20	19	18	17																																																																										
						16	15	14						9	7	6	5		3	2	1																																																																										
AVAILABLE	NOT APPLICABLE	34566-3683	G	9	H	ST GRAY	<table border="1"> <tr><td></td><td></td><td></td><td></td><td></td><td></td><td></td><td></td><td></td><td></td><td></td><td></td><td></td><td></td><td></td><td></td><td></td><td></td><td></td><td></td><td></td><td>61</td></tr> <tr><td></td><td></td><td></td><td></td><td></td><td></td><td></td><td></td><td></td><td></td><td></td><td>32</td><td></td><td></td><td></td><td></td><td></td><td></td><td></td><td></td><td></td><td></td></tr> <tr><td></td><td></td><td></td><td></td><td></td><td></td><td></td><td></td><td></td><td></td><td></td><td></td><td></td><td></td><td></td><td></td><td></td><td></td><td></td><td></td><td></td><td></td></tr> <tr><td></td><td></td><td></td><td></td><td></td><td></td><td></td><td></td><td></td><td></td><td></td><td></td><td></td><td></td><td></td><td></td><td></td><td></td><td></td><td></td><td></td><td>1</td></tr> </table>																						61												32																																																						1
																					61																																																																										
											32																																																																																				
																					1																																																																										
AVAILABLE	NOT APPLICABLE	34566-3693	G	0	C	BLUE	<table border="1"> <tr><td>72</td><td>70</td><td>68</td><td>67</td><td>66</td><td></td><td></td><td></td><td>63</td><td>62</td><td></td><td></td><td></td><td>59</td><td>57</td><td></td><td></td><td></td><td></td><td></td><td>53</td></tr> <tr><td>52</td><td>51</td><td></td><td>48</td><td>47</td><td>46</td><td></td><td></td><td>44</td><td>42</td><td></td><td></td><td></td><td>40</td><td>39</td><td>38</td><td></td><td></td><td></td><td>34</td><td>33</td></tr> <tr><td></td><td></td><td></td><td>32</td><td></td><td>30</td><td></td><td></td><td></td><td>27</td><td>26</td><td>25</td><td></td><td></td><td></td><td></td><td>22</td><td>21</td><td></td><td></td><td></td></tr> <tr><td></td><td></td><td></td><td></td><td></td><td>15</td><td>14</td><td></td><td></td><td></td><td></td><td>10</td><td>9</td><td></td><td></td><td></td><td>6</td><td>5</td><td>4</td><td></td><td></td></tr> </table>	72	70	68	67	66				63	62				59	57						53	52	51		48	47	46			44	42				40	39	38				34	33				32		30				27	26	25					22	21									15	14					10	9				6	5	4						
72	70	68	67	66				63	62				59	57						53																																																																											
52	51		48	47	46			44	42				40	39	38				34	33																																																																											
			32		30				27	26	25					22	21																																																																														
					15	14					10	9				6	5	4																																																																													
AVAILABLE	NOT APPLICABLE	34566-3713	G	0	C	BLUE	<table border="1"> <tr><td>72</td><td>70</td><td>68</td><td>67</td><td>66</td><td></td><td></td><td></td><td>63</td><td>62</td><td></td><td></td><td></td><td>59</td><td>57</td><td></td><td></td><td></td><td></td><td></td><td>53</td></tr> <tr><td>52</td><td>51</td><td></td><td>48</td><td>47</td><td>46</td><td></td><td></td><td>44</td><td>42</td><td></td><td></td><td></td><td>40</td><td>39</td><td></td><td></td><td></td><td></td><td>34</td><td>33</td></tr> <tr><td></td><td></td><td></td><td>32</td><td></td><td>30</td><td></td><td></td><td></td><td>27</td><td>26</td><td>25</td><td></td><td></td><td></td><td></td><td>22</td><td>21</td><td></td><td></td><td></td></tr> <tr><td></td><td></td><td></td><td></td><td></td><td>15</td><td>14</td><td></td><td></td><td></td><td></td><td>10</td><td>9</td><td></td><td></td><td></td><td>6</td><td>5</td><td>4</td><td></td><td></td></tr> </table>	72	70	68	67	66				63	62				59	57						53	52	51		48	47	46			44	42				40	39					34	33				32		30				27	26	25					22	21									15	14					10	9				6	5	4						
72	70	68	67	66				63	62				59	57						53																																																																											
52	51		48	47	46			44	42				40	39					34	33																																																																											
			32		30				27	26	25					22	21																																																																														
					15	14					10	9				6	5	4																																																																													

ENTER DESCRIPTION EC NO: UAU2013-0662 DRAWN BY: CHYD CHECKED BY: APPR:KOSHY DATE: 2012/11/21 REV: 1/06	QUALITY SYMBOLS	GENERAL TOLERANCES (UNLESS SPECIFIED)	DIMENSION STYLE	SCALE	DESIGN UNITS	THIRD ANGLE PROJECTION
	▽=0	4 PLACES ±---+---	MM ONLY	1:1	METRIC	☉
	▽=0	3 PLACES ±---+---				
	▽=0	2 PLACES ±---+---				
	1 PLACE ±---+---					
	0 PLACE ±---+---					
	ANGULAR ±---+---					
	DRAFT WHERE APPLICABLE MUST REMAIN WITHIN DIMENSIONS					
			DRAWN BY: SKRAJENDRANA	DATE: 2011/02/14	TITLE: MX123 66/73/80CKT HRNS CONN ASSY	
			CHECKED BY: MYANSLAMBROU	DATE: 2011/02/14		
			APPROVED BY:	DATE:		
			MATERIAL NO. SEE BOM TABLE	DOCUMENT NO. SD-34566-001	SHEET NO. 43 OF 59	
			THIS DRAWING CONTAINS INFORMATION THAT IS PROPRIETARY TO MOLEX INCORPORATED AND SHOULD NOT BE USED WITHOUT WRITTEN PERMISSION			

STATUS	GM PART #	MATERIAL #	PART/MATERIAL REVISION	WIRE DRESS OPTION	KEY OPTION	COLOR (TPA)	NUMBERS INDICATE CAVITIES OPEN FOR CIRCUITS																																																																																					
AVAILABLE	NOT APPLICABLE	34566-3823	G	0	A	BLACK	<table border="1"> <tr><td></td><td>70</td><td>69</td><td></td><td></td><td></td><td>63</td><td>61</td><td></td><td></td><td>58</td><td>57</td><td>56</td><td>55</td><td>54</td><td>53</td></tr> <tr><td>52</td><td>51</td><td>49</td><td></td><td></td><td></td><td>44</td><td>43</td><td>41</td><td></td><td></td><td></td><td>37</td><td>36</td><td></td><td>34</td></tr> <tr><td></td><td></td><td></td><td>73</td><td>32</td><td></td><td></td><td>27</td><td>26</td><td></td><td></td><td></td><td></td><td></td><td>19</td><td>18</td></tr> <tr><td></td><td></td><td></td><td></td><td>16</td><td>15</td><td></td><td></td><td>11</td><td>10</td><td></td><td></td><td></td><td></td><td>3</td><td></td></tr> </table>		70	69				63	61			58	57	56	55	54	53	52	51	49				44	43	41				37	36		34				73	32			27	26						19	18					16	15			11	10					3																						
	70	69				63	61			58	57	56	55	54	53																																																																													
52	51	49				44	43	41				37	36		34																																																																													
			73	32			27	26						19	18																																																																													
				16	15			11	10					3																																																																														
AVAILABLE	NOT APPLICABLE	34566-3833	G	0	A	BLACK	<table border="1"> <tr><td></td><td>70</td><td>69</td><td></td><td></td><td></td><td>63</td><td>62</td><td>61</td><td></td><td></td><td></td><td>57</td><td>56</td><td>55</td><td>54</td><td>53</td></tr> <tr><td>52</td><td>51</td><td>49</td><td></td><td></td><td></td><td>44</td><td>43</td><td>42</td><td>41</td><td></td><td></td><td></td><td>37</td><td>36</td><td></td><td>34</td></tr> <tr><td></td><td></td><td></td><td>73</td><td>32</td><td></td><td>29</td><td>28</td><td>27</td><td>26</td><td></td><td>23</td><td></td><td></td><td></td><td>19</td><td>18</td></tr> <tr><td></td><td></td><td></td><td></td><td>16</td><td>15</td><td>13</td><td>12</td><td>11</td><td>10</td><td>8</td><td></td><td></td><td></td><td></td><td>3</td><td></td></tr> </table>		70	69				63	62	61				57	56	55	54	53	52	51	49				44	43	42	41				37	36		34				73	32		29	28	27	26		23				19	18					16	15	13	12	11	10	8					3																		
	70	69				63	62	61				57	56	55	54	53																																																																												
52	51	49				44	43	42	41				37	36		34																																																																												
			73	32		29	28	27	26		23				19	18																																																																												
				16	15	13	12	11	10	8					3																																																																													
AVAILABLE	NOT APPLICABLE	34566-3843	G	0	A	BLACK	<table border="1"> <tr><td>72</td><td>71</td><td>70</td><td>69</td><td>68</td><td>67</td><td>66</td><td></td><td>64</td><td>63</td><td>62</td><td></td><td>60</td><td>59</td><td></td><td></td><td>55</td><td>54</td><td>53</td></tr> <tr><td>52</td><td></td><td></td><td>49</td><td>48</td><td></td><td></td><td></td><td>44</td><td>43</td><td>42</td><td>41</td><td>40</td><td>39</td><td></td><td></td><td></td><td>35</td><td>34</td><td>33</td></tr> <tr><td></td><td></td><td></td><td></td><td></td><td></td><td></td><td>73</td><td>32</td><td></td><td>29</td><td>28</td><td>27</td><td>25</td><td>24</td><td>23</td><td></td><td></td><td>19</td><td>18</td><td>17</td></tr> <tr><td></td><td></td><td></td><td></td><td></td><td></td><td></td><td></td><td>16</td><td></td><td>13</td><td>12</td><td>11</td><td>9</td><td>8</td><td>7</td><td>6</td><td>5</td><td>4</td><td>3</td><td>2</td><td>1</td></tr> </table>	72	71	70	69	68	67	66		64	63	62		60	59			55	54	53	52			49	48				44	43	42	41	40	39				35	34	33								73	32		29	28	27	25	24	23			19	18	17									16		13	12	11	9	8	7	6	5	4	3	2	1			
72	71	70	69	68	67	66		64	63	62		60	59			55	54	53																																																																										
52			49	48				44	43	42	41	40	39				35	34	33																																																																									
							73	32		29	28	27	25	24	23			19	18	17																																																																								
								16		13	12	11	9	8	7	6	5	4	3	2	1																																																																							
AVAILABLE	NOT APPLICABLE	34566-3853	G	0	A	BLACK	<table border="1"> <tr><td>72</td><td>71</td><td>70</td><td>69</td><td>68</td><td>67</td><td>66</td><td>65</td><td>64</td><td>63</td><td>62</td><td></td><td>60</td><td>59</td><td></td><td></td><td>55</td><td>54</td><td>53</td></tr> <tr><td>52</td><td></td><td></td><td>49</td><td>48</td><td></td><td></td><td></td><td>45</td><td>44</td><td>43</td><td>42</td><td>41</td><td>40</td><td>39</td><td></td><td></td><td>35</td><td>34</td><td>33</td></tr> <tr><td></td><td></td><td></td><td></td><td></td><td></td><td></td><td></td><td></td><td></td><td></td><td></td><td></td><td></td><td></td><td></td><td></td><td></td><td>19</td><td>18</td><td>17</td></tr> <tr><td></td><td></td><td></td><td></td><td></td><td></td><td></td><td></td><td></td><td></td><td></td><td></td><td></td><td></td><td></td><td></td><td></td><td></td><td></td><td></td><td></td><td>1</td></tr> </table>	72	71	70	69	68	67	66	65	64	63	62		60	59			55	54	53	52			49	48				45	44	43	42	41	40	39			35	34	33																			19	18	17																						1			
72	71	70	69	68	67	66	65	64	63	62		60	59			55	54	53																																																																										
52			49	48				45	44	43	42	41	40	39			35	34	33																																																																									
																		19	18	17																																																																								
																					1																																																																							
AVAILABLE	NOT APPLICABLE	34566-3863	G	0	B	ST GRAY	<table border="1"> <tr><td>72</td><td>71</td><td>70</td><td></td><td>68</td><td>67</td><td>66</td><td></td><td></td><td></td><td>62</td><td>61</td><td>60</td><td>59</td><td>58</td><td>57</td><td>56</td><td>55</td><td>54</td><td>53</td></tr> <tr><td>52</td><td>51</td><td>50</td><td></td><td>48</td><td>47</td><td>46</td><td></td><td></td><td></td><td>42</td><td>41</td><td>40</td><td>39</td><td>38</td><td>37</td><td>36</td><td>35</td><td>34</td><td>33</td></tr> <tr><td></td><td></td><td></td><td></td><td></td><td></td><td></td><td>73</td><td>32</td><td>31</td><td>30</td><td>29</td><td>28</td><td>27</td><td>26</td><td>25</td><td>24</td><td></td><td></td><td>17</td></tr> <tr><td></td><td></td><td></td><td></td><td></td><td></td><td></td><td></td><td>16</td><td>15</td><td>14</td><td>13</td><td></td><td></td><td>10</td><td>8</td><td></td><td></td><td></td><td></td><td>2</td><td>1</td></tr> </table>	72	71	70		68	67	66				62	61	60	59	58	57	56	55	54	53	52	51	50		48	47	46				42	41	40	39	38	37	36	35	34	33								73	32	31	30	29	28	27	26	25	24			17									16	15	14	13			10	8					2	1			
72	71	70		68	67	66				62	61	60	59	58	57	56	55	54	53																																																																									
52	51	50		48	47	46				42	41	40	39	38	37	36	35	34	33																																																																									
							73	32	31	30	29	28	27	26	25	24			17																																																																									
								16	15	14	13			10	8					2	1																																																																							
AVAILABLE	NOT APPLICABLE	34566-3873	G	0	B	ST GRAY	<table border="1"> <tr><td></td><td></td><td></td><td></td><td></td><td></td><td></td><td></td><td></td><td>63</td><td></td><td></td><td></td><td>59</td><td>58</td><td>57</td><td>56</td><td>55</td><td></td><td></td></tr> <tr><td></td><td></td><td></td><td>50</td><td>49</td><td>48</td><td></td><td></td><td>46</td><td>45</td><td>43</td><td></td><td></td><td>39</td><td>38</td><td>37</td><td>36</td><td>35</td><td>34</td><td></td></tr> <tr><td></td><td></td><td></td><td></td><td></td><td></td><td></td><td></td><td></td><td></td><td>29</td><td>27</td><td></td><td></td><td>23</td><td>22</td><td>21</td><td></td><td></td><td>18</td></tr> <tr><td></td><td></td><td></td><td></td><td></td><td></td><td></td><td></td><td></td><td></td><td></td><td></td><td></td><td></td><td>7</td><td>6</td><td>5</td><td>4</td><td>3</td><td></td><td></td></tr> </table>										63				59	58	57	56	55						50	49	48			46	45	43			39	38	37	36	35	34												29	27			23	22	21			18															7	6	5	4	3						
									63				59	58	57	56	55																																																																											
			50	49	48			46	45	43			39	38	37	36	35	34																																																																										
										29	27			23	22	21			18																																																																									
														7	6	5	4	3																																																																										
AVAILABLE	NOT APPLICABLE	34566-3883	G	0	B	ST GRAY	<table border="1"> <tr><td></td><td></td><td></td><td></td><td></td><td></td><td>67</td><td>66</td><td></td><td></td><td></td><td></td><td></td><td>59</td><td>58</td><td>57</td><td>56</td><td>55</td><td></td><td>53</td></tr> <tr><td></td><td></td><td></td><td></td><td></td><td></td><td></td><td></td><td></td><td></td><td></td><td></td><td></td><td></td><td>39</td><td>38</td><td>37</td><td>36</td><td>35</td><td>34</td><td>33</td></tr> <tr><td></td><td></td><td></td><td></td><td></td><td></td><td></td><td></td><td></td><td></td><td></td><td></td><td></td><td></td><td></td><td></td><td></td><td></td><td></td><td>18</td><td></td></tr> <tr><td></td><td></td><td></td><td></td><td></td><td></td><td></td><td></td><td></td><td></td><td></td><td></td><td></td><td></td><td></td><td>8</td><td>7</td><td>6</td><td>5</td><td>4</td><td>3</td><td></td></tr> </table>							67	66						59	58	57	56	55		53															39	38	37	36	35	34	33																				18																	8	7	6	5	4	3		
						67	66						59	58	57	56	55		53																																																																									
														39	38	37	36	35	34	33																																																																								
																			18																																																																									
															8	7	6	5	4	3																																																																								
AVAILABLE	NOT APPLICABLE	34566-3893	G	0	C	BLUE	<table border="1"> <tr><td>72</td><td>70</td><td></td><td>68</td><td>67</td><td>66</td><td></td><td></td><td></td><td>63</td><td>62</td><td></td><td></td><td>59</td><td>57</td><td></td><td></td><td></td><td></td><td>53</td></tr> <tr><td>52</td><td>51</td><td></td><td>48</td><td>47</td><td>46</td><td></td><td></td><td>44</td><td></td><td>42</td><td></td><td></td><td></td><td></td><td></td><td></td><td></td><td></td><td>34</td><td>33</td></tr> <tr><td></td><td></td><td></td><td></td><td></td><td></td><td></td><td></td><td></td><td></td><td></td><td></td><td></td><td></td><td></td><td></td><td></td><td></td><td></td><td></td><td></td><td></td></tr> <tr><td></td><td></td><td></td><td></td><td></td><td></td><td></td><td></td><td></td><td></td><td></td><td></td><td></td><td></td><td></td><td></td><td></td><td></td><td></td><td></td><td></td><td></td></tr> </table>	72	70		68	67	66				63	62			59	57					53	52	51		48	47	46			44		42									34	33																																												
72	70		68	67	66				63	62			59	57					53																																																																									
52	51		48	47	46			44		42									34	33																																																																								

ENTER DESCRIPTION EC NO: UAU2013-0662 DRAWN BY: T806 CHECKED BY: T806 APPR: IKOSHY DATE: 2012/11/21 REV:	QUALITY SYMBOLS ∇=0 ∇=0 ∇=0	GENERAL TOLERANCES (UNLESS SPECIFIED): mm INCH 4 PLACES ±---+--- 3 PLACES ±---+--- 2 PLACES ±---+--- 1 PLACE ±---+--- 0 PLACE ±---+---	DIMENSION STYLE MM ONLY	SCALE METRIC	DESIGN UNITS METRIC	THIRD ANGLE PROJECTION
	DRAWN BY: SKRAJENDRANA DATE: 2011/02/14 CHECKED BY: MYANSLAMBROU DATE: 2011/02/14 APPROVED BY:	TITLE MX123 66/73/80CKT HRNS CONN ASSY	MATERIAL NO. SEE BOM TABLE	DOCUMENT NO. SD-34566-001	SHEET NO. 45 OF 59	

STATUS	GM PART #	MATERIAL #	PART/MATERIAL REVISION	WIRE DRESS OPTION	KEY OPTION	COLOR (TPA)	NUMBERS INDICATE CAVITIES OPEN FOR CIRCUITS																																																																																					
AVAILABLE	NOT APPLICABLE	34566-3913	G	0	A	BLACK	<table border="1"> <tr><td>71</td><td>70</td><td>69</td><td></td><td></td><td></td><td>64</td><td>63</td><td></td><td>60</td><td>58</td><td>57</td><td>56</td><td>55</td><td>54</td><td>53</td></tr> <tr><td>52</td><td>51</td><td>49</td><td></td><td></td><td></td><td>45</td><td>44</td><td>43</td><td>42</td><td>41</td><td></td><td></td><td>37</td><td>36</td><td>34</td></tr> <tr><td></td><td></td><td></td><td>32</td><td>30</td><td></td><td>28</td><td>26</td><td></td><td></td><td>23</td><td></td><td></td><td>21</td><td>19</td><td>18</td></tr> <tr><td></td><td></td><td></td><td>16</td><td>15</td><td></td><td>12</td><td>10</td><td></td><td></td><td>8</td><td></td><td></td><td>5</td><td>3</td><td></td></tr> <tr><td></td><td></td><td></td><td></td><td></td><td></td><td></td><td></td><td></td><td></td><td></td><td></td><td></td><td></td><td></td><td></td></tr> </table>	71	70	69				64	63		60	58	57	56	55	54	53	52	51	49				45	44	43	42	41			37	36	34				32	30		28	26			23			21	19	18				16	15		12	10			8			5	3																						
71	70	69				64	63		60	58	57	56	55	54	53																																																																													
52	51	49				45	44	43	42	41			37	36	34																																																																													
			32	30		28	26			23			21	19	18																																																																													
			16	15		12	10			8			5	3																																																																														
AVAILABLE	NOT APPLICABLE	34566-3923	G	0	B	ST GRAY	<table border="1"> <tr><td>72</td><td>70</td><td>68</td><td>66</td><td></td><td></td><td></td><td></td><td></td><td>60</td><td>59</td><td></td><td></td><td>55</td><td>54</td><td>53</td></tr> <tr><td>52</td><td></td><td>50</td><td>48</td><td>46</td><td></td><td></td><td></td><td></td><td>40</td><td>39</td><td></td><td></td><td>35</td><td>34</td><td>33</td></tr> <tr><td></td><td></td><td></td><td>32</td><td>31</td><td>30</td><td>29</td><td>28</td><td>27</td><td>26</td><td>25</td><td>24</td><td>23</td><td></td><td>19</td><td>18</td></tr> <tr><td></td><td></td><td></td><td>16</td><td></td><td></td><td></td><td></td><td></td><td>10</td><td>9</td><td>8</td><td>7</td><td></td><td></td><td></td></tr> <tr><td></td><td></td><td></td><td></td><td></td><td></td><td></td><td></td><td></td><td></td><td></td><td></td><td></td><td></td><td></td><td></td></tr> </table>	72	70	68	66						60	59			55	54	53	52		50	48	46					40	39			35	34	33				32	31	30	29	28	27	26	25	24	23		19	18				16						10	9	8	7																								
72	70	68	66						60	59			55	54	53																																																																													
52		50	48	46					40	39			35	34	33																																																																													
			32	31	30	29	28	27	26	25	24	23		19	18																																																																													
			16						10	9	8	7																																																																																
AVAILABLE	NOT APPLICABLE	34566-3933	G	0	A	BLACK	<table border="1"> <tr><td>71</td><td>70</td><td>69</td><td></td><td></td><td></td><td>64</td><td>63</td><td></td><td>60</td><td>58</td><td>57</td><td>56</td><td>55</td><td>54</td><td>53</td></tr> <tr><td>52</td><td>51</td><td>49</td><td></td><td></td><td></td><td>45</td><td>44</td><td>43</td><td>42</td><td>41</td><td></td><td></td><td></td><td></td><td>34</td></tr> <tr><td></td><td></td><td></td><td>32</td><td>30</td><td></td><td>28</td><td>26</td><td></td><td></td><td></td><td></td><td></td><td></td><td>19</td><td>18</td></tr> <tr><td></td><td></td><td></td><td>16</td><td>15</td><td></td><td>12</td><td>10</td><td></td><td></td><td></td><td></td><td></td><td></td><td>3</td><td></td></tr> <tr><td></td><td></td><td></td><td></td><td></td><td></td><td></td><td></td><td></td><td></td><td></td><td></td><td></td><td></td><td></td><td></td></tr> </table>	71	70	69				64	63		60	58	57	56	55	54	53	52	51	49				45	44	43	42	41					34				32	30		28	26							19	18				16	15		12	10							3																						
71	70	69				64	63		60	58	57	56	55	54	53																																																																													
52	51	49				45	44	43	42	41					34																																																																													
			32	30		28	26							19	18																																																																													
			16	15		12	10							3																																																																														
AVAILABLE	NOT APPLICABLE	34566-3943	G	0	C	BLUE	<table border="1"> <tr><td>72</td><td>70</td><td>68</td><td>66</td><td></td><td></td><td></td><td></td><td></td><td>60</td><td>59</td><td></td><td></td><td>55</td><td>54</td><td>53</td></tr> <tr><td>52</td><td></td><td>50</td><td>48</td><td>46</td><td></td><td></td><td></td><td></td><td>40</td><td>39</td><td></td><td></td><td>35</td><td>34</td><td>33</td></tr> <tr><td></td><td></td><td></td><td>32</td><td>31</td><td>30</td><td>29</td><td>28</td><td>27</td><td>26</td><td>25</td><td>24</td><td></td><td></td><td></td><td></td></tr> <tr><td></td><td></td><td></td><td>16</td><td></td><td></td><td></td><td></td><td></td><td>10</td><td>9</td><td>8</td><td></td><td></td><td></td><td></td></tr> <tr><td></td><td></td><td></td><td></td><td></td><td></td><td></td><td></td><td></td><td></td><td></td><td></td><td></td><td></td><td></td><td></td></tr> </table>	72	70	68	66						60	59			55	54	53	52		50	48	46					40	39			35	34	33				32	31	30	29	28	27	26	25	24								16						10	9	8																									
72	70	68	66						60	59			55	54	53																																																																													
52		50	48	46					40	39			35	34	33																																																																													
			32	31	30	29	28	27	26	25	24																																																																																	
			16						10	9	8																																																																																	
AVAILABLE	NOT APPLICABLE	34566-3953	G	0	C	BLUE	<table border="1"> <tr><td>72</td><td>70</td><td>68</td><td></td><td></td><td></td><td>63</td><td>62</td><td></td><td>59</td><td>57</td><td></td><td></td><td></td><td></td><td>53</td></tr> <tr><td>52</td><td>51</td><td></td><td>48</td><td>47</td><td>46</td><td>44</td><td>42</td><td>40</td><td>39</td><td></td><td></td><td></td><td></td><td></td><td>34</td></tr> <tr><td></td><td></td><td></td><td>32</td><td>30</td><td></td><td></td><td>26</td><td>25</td><td></td><td>23</td><td>22</td><td>21</td><td>20</td><td></td><td></td></tr> <tr><td></td><td></td><td></td><td>15</td><td>14</td><td>13</td><td></td><td></td><td></td><td>7</td><td>6</td><td>5</td><td>4</td><td></td><td></td><td></td></tr> <tr><td></td><td></td><td></td><td></td><td></td><td></td><td></td><td></td><td></td><td></td><td></td><td></td><td></td><td></td><td></td><td></td></tr> </table>	72	70	68				63	62		59	57					53	52	51		48	47	46	44	42	40	39						34				32	30			26	25		23	22	21	20						15	14	13				7	6	5	4																								
72	70	68				63	62		59	57					53																																																																													
52	51		48	47	46	44	42	40	39						34																																																																													
			32	30			26	25		23	22	21	20																																																																															
			15	14	13				7	6	5	4																																																																																
AVAILABLE	NOT APPLICABLE	34566-3963	G	0	C	BLUE	<table border="1"> <tr><td>72</td><td>70</td><td>68</td><td>67</td><td>66</td><td></td><td>63</td><td>62</td><td></td><td>59</td><td>57</td><td></td><td></td><td></td><td></td><td>53</td></tr> <tr><td>52</td><td>51</td><td></td><td>48</td><td>47</td><td>46</td><td>44</td><td>42</td><td>40</td><td>39</td><td>38</td><td></td><td></td><td></td><td></td><td>34</td></tr> <tr><td></td><td></td><td></td><td>32</td><td>30</td><td></td><td></td><td>26</td><td>25</td><td></td><td></td><td>22</td><td>21</td><td></td><td></td><td></td></tr> <tr><td></td><td></td><td></td><td>15</td><td>14</td><td></td><td></td><td>10</td><td>9</td><td></td><td></td><td>6</td><td>5</td><td>4</td><td></td><td></td></tr> <tr><td></td><td></td><td></td><td></td><td></td><td></td><td></td><td></td><td></td><td></td><td></td><td></td><td></td><td></td><td></td><td></td></tr> </table>	72	70	68	67	66		63	62		59	57					53	52	51		48	47	46	44	42	40	39	38					34				32	30			26	25			22	21							15	14			10	9			6	5	4																							
72	70	68	67	66		63	62		59	57					53																																																																													
52	51		48	47	46	44	42	40	39	38					34																																																																													
			32	30			26	25			22	21																																																																																
			15	14			10	9			6	5	4																																																																															
AVAILABLE	NOT APPLICABLE	34566-3973	G	0	C	BLUE	<table border="1"> <tr><td>72</td><td>70</td><td>68</td><td>67</td><td></td><td></td><td>63</td><td>62</td><td></td><td>59</td><td>57</td><td></td><td></td><td></td><td></td><td>53</td></tr> <tr><td>52</td><td>51</td><td></td><td>48</td><td>47</td><td>46</td><td>44</td><td>42</td><td>40</td><td>39</td><td>38</td><td></td><td></td><td></td><td></td><td>34</td></tr> <tr><td></td><td></td><td></td><td>32</td><td>30</td><td></td><td></td><td>26</td><td>25</td><td></td><td></td><td>22</td><td>21</td><td></td><td></td><td></td></tr> <tr><td></td><td></td><td></td><td>15</td><td>14</td><td></td><td></td><td></td><td></td><td></td><td></td><td>6</td><td>5</td><td>4</td><td></td><td></td></tr> <tr><td></td><td></td><td></td><td></td><td></td><td></td><td></td><td></td><td></td><td></td><td></td><td></td><td></td><td></td><td></td><td></td></tr> </table>	72	70	68	67			63	62		59	57					53	52	51		48	47	46	44	42	40	39	38					34				32	30			26	25			22	21							15	14							6	5	4																							
72	70	68	67			63	62		59	57					53																																																																													
52	51		48	47	46	44	42	40	39	38					34																																																																													
			32	30			26	25			22	21																																																																																
			15	14							6	5	4																																																																															
AVAILABLE	NOT APPLICABLE	34566-3983	G	0	A	BLACK	<table border="1"> <tr><td>72</td><td>71</td><td>70</td><td>69</td><td></td><td></td><td>64</td><td>63</td><td></td><td>60</td><td>59</td><td>58</td><td>57</td><td>56</td><td>55</td><td>54</td><td>53</td></tr> <tr><td>52</td><td>51</td><td></td><td>49</td><td></td><td></td><td>45</td><td>44</td><td>43</td><td>42</td><td>41</td><td>40</td><td></td><td></td><td>37</td><td>36</td><td>34</td></tr> <tr><td></td><td></td><td></td><td></td><td></td><td></td><td>32</td><td>30</td><td></td><td>28</td><td>26</td><td></td><td></td><td></td><td></td><td>19</td><td>18</td></tr> <tr><td></td><td></td><td></td><td></td><td></td><td></td><td>16</td><td>15</td><td></td><td>12</td><td>10</td><td></td><td></td><td></td><td></td><td>3</td><td></td></tr> <tr><td></td><td></td><td></td><td></td><td></td><td></td><td></td><td></td><td></td><td></td><td></td><td></td><td></td><td></td><td></td><td></td><td></td></tr> </table>	72	71	70	69			64	63		60	59	58	57	56	55	54	53	52	51		49			45	44	43	42	41	40			37	36	34							32	30		28	26					19	18							16	15		12	10					3																		
72	71	70	69			64	63		60	59	58	57	56	55	54	53																																																																												
52	51		49			45	44	43	42	41	40			37	36	34																																																																												
						32	30		28	26					19	18																																																																												
						16	15		12	10					3																																																																													
AVAILABLE	NOT APPLICABLE	34566-3993	G	0	A	BLACK	<table border="1"> <tr><td></td><td>70</td><td>69</td><td></td><td></td><td></td><td>63</td><td>62</td><td>61</td><td>60</td><td>58</td><td>57</td><td>56</td><td>55</td><td>54</td><td>53</td></tr> <tr><td>52</td><td>51</td><td>49</td><td></td><td></td><td></td><td>44</td><td>43</td><td>42</td><td>41</td><td>40</td><td></td><td></td><td>37</td><td>36</td><td>34</td></tr> <tr><td></td><td></td><td></td><td>32</td><td></td><td></td><td>29</td><td>28</td><td>27</td><td>26</td><td></td><td></td><td></td><td></td><td>19</td><td>18</td></tr> <tr><td></td><td></td><td></td><td>16</td><td>15</td><td></td><td>13</td><td>12</td><td>11</td><td>10</td><td></td><td></td><td></td><td></td><td>3</td><td></td></tr> <tr><td></td><td></td><td></td><td></td><td></td><td></td><td></td><td></td><td></td><td></td><td></td><td></td><td></td><td></td><td></td><td></td></tr> </table>		70	69				63	62	61	60	58	57	56	55	54	53	52	51	49				44	43	42	41	40			37	36	34				32			29	28	27	26					19	18				16	15		13	12	11	10					3																						
	70	69				63	62	61	60	58	57	56	55	54	53																																																																													
52	51	49				44	43	42	41	40			37	36	34																																																																													
			32			29	28	27	26					19	18																																																																													
			16	15		13	12	11	10					3																																																																														

ENTER DESCRIPTION ELEC NO: UAU2013-0662 DRAWN BY: CHKD: APPR: WOSHY 2012/11/21 F86	QUALITY SYMBOLS	GENERAL TOLERANCES (UNLESS SPECIFIED)	DIMENSION STYLE	SCALE	DESIGN UNITS	THIRD ANGLE PROJECTION	
	∇=0 ∇=0 ∇=0	4 PLACES +---+ 3 PLACES +---+ 2 PLACES +---+ 1 PLACE +---+ 0 PLACE +---+	mm INCH +---+ +---+ +---+ +---+ +---+	MM ONLY DRAWN BY: SKRA JENDRANA 2011/02/14 CHECKED BY: MYANSLAMBROU 2011/02/14 APPROVED BY:	DATE: 2012/11/21 DATE: 2011/02/14 DATE:	METRIC	MX123 66/73/80CKT HRNS CONN ASSY
	ANGULAR ±---° DRAFT WHERE APPLICABLE MUST REMAIN WITHIN DIMENSIONS	SEE BOM TABLE	MATERIAL NO. DOCUMENT NO.	SD-34566-001	SHEET NO. 46 OF 59		
	THIS DRAWING CONTAINS INFORMATION THAT IS PROPRIETARY TO MOLEX INCORPORATED AND SHOULD NOT BE USED WITHOUT WRITTEN PERMISSION						

STATUS	GM PART #	MATERIAL #	PART/MATERIAL REVISION	WIRE DRESS OPTION	KEY OPTION	COLOR (TPA)	NUMBERS INDICATE CAVITIES OPEN FOR CIRCUITS																																																																											
AVAILABLE	NOT APPLICABLE	34566-4013	G	0	B	ST GRAY	<table border="1"> <tr><td>72</td><td>70</td><td>68</td><td>66</td><td></td><td></td><td></td><td></td><td>60</td><td>59</td><td></td><td></td><td>55</td><td>54</td><td>53</td></tr> <tr><td>52</td><td>50</td><td>48</td><td>46</td><td></td><td></td><td></td><td></td><td>40</td><td>39</td><td></td><td></td><td>35</td><td>34</td><td>33</td></tr> <tr><td colspan="2">73</td><td>32</td><td>31</td><td>30</td><td>29</td><td>28</td><td>27</td><td>26</td><td>25</td><td>24</td><td></td><td></td><td></td><td>17</td></tr> <tr><td colspan="2"></td><td>16</td><td>15</td><td>14</td><td>13</td><td></td><td></td><td>10</td><td>9</td><td>8</td><td></td><td></td><td></td><td>2</td><td>1</td></tr> </table>	72	70	68	66					60	59			55	54	53	52	50	48	46					40	39			35	34	33	73		32	31	30	29	28	27	26	25	24				17			16	15	14	13			10	9	8				2	1														
72	70	68	66					60	59			55	54	53																																																																				
52	50	48	46					40	39			35	34	33																																																																				
73		32	31	30	29	28	27	26	25	24				17																																																																				
		16	15	14	13			10	9	8				2	1																																																																			
AVAILABLE	NOT APPLICABLE	34566-4023	G	0	B	ST GRAY	<table border="1"> <tr><td>72</td><td>71</td><td>70</td><td>68</td><td>67</td><td>66</td><td></td><td></td><td>62</td><td>61</td><td>60</td><td>59</td><td>58</td><td>57</td><td>56</td><td>55</td><td>54</td><td>53</td></tr> <tr><td>52</td><td>51</td><td>50</td><td>48</td><td>47</td><td>46</td><td></td><td></td><td>42</td><td>41</td><td>40</td><td>39</td><td>38</td><td>37</td><td>36</td><td>35</td><td>34</td><td>33</td></tr> <tr><td colspan="2">73</td><td>32</td><td>31</td><td>30</td><td>29</td><td>28</td><td>27</td><td>26</td><td>25</td><td>24</td><td></td><td></td><td></td><td></td><td></td><td></td><td></td></tr> <tr><td colspan="2"></td><td>16</td><td>15</td><td>14</td><td>13</td><td></td><td></td><td>10</td><td>9</td><td>8</td><td></td><td></td><td></td><td></td><td></td><td></td><td></td></tr> </table>	72	71	70	68	67	66			62	61	60	59	58	57	56	55	54	53	52	51	50	48	47	46			42	41	40	39	38	37	36	35	34	33	73		32	31	30	29	28	27	26	25	24										16	15	14	13			10	9	8										
72	71	70	68	67	66			62	61	60	59	58	57	56	55	54	53																																																																	
52	51	50	48	47	46			42	41	40	39	38	37	36	35	34	33																																																																	
73		32	31	30	29	28	27	26	25	24																																																																								
		16	15	14	13			10	9	8																																																																								
AVAILABLE	NOT APPLICABLE	34566-4033	G	0	C	BLUE	<table border="1"> <tr><td>72</td><td>70</td><td>68</td><td></td><td></td><td></td><td></td><td>63</td><td>62</td><td></td><td>59</td><td>58</td><td>57</td><td></td><td></td><td></td><td></td><td>53</td></tr> <tr><td>52</td><td>51</td><td></td><td>48</td><td>47</td><td></td><td>44</td><td>42</td><td>41</td><td>40</td><td>39</td><td>38</td><td></td><td></td><td></td><td></td><td></td><td>34</td><td>33</td></tr> <tr><td colspan="2">73</td><td>32</td><td></td><td>30</td><td></td><td></td><td>26</td><td>25</td><td>24</td><td></td><td></td><td>22</td><td>21</td><td>20</td><td></td><td></td><td></td><td>17</td></tr> <tr><td colspan="2"></td><td></td><td>15</td><td>14</td><td>13</td><td></td><td></td><td></td><td></td><td></td><td></td><td>6</td><td>5</td><td>4</td><td></td><td></td><td></td><td>1</td></tr> </table>	72	70	68					63	62		59	58	57					53	52	51		48	47		44	42	41	40	39	38						34	33	73		32		30			26	25	24			22	21	20				17				15	14	13							6	5	4				1
72	70	68					63	62		59	58	57					53																																																																	
52	51		48	47		44	42	41	40	39	38						34	33																																																																
73		32		30			26	25	24			22	21	20				17																																																																
			15	14	13							6	5	4				1																																																																
AVAILABLE	NOT APPLICABLE	34566-4043	G	0	A	BLACK	<table border="1"> <tr><td></td><td>71</td><td>70</td><td>69</td><td>67</td><td></td><td>64</td><td>63</td><td></td><td>60</td><td></td><td></td><td>57</td><td>56</td><td>55</td><td>54</td><td>53</td></tr> <tr><td>52</td><td>51</td><td></td><td>49</td><td></td><td></td><td>45</td><td>44</td><td>43</td><td>42</td><td>41</td><td></td><td></td><td>37</td><td>36</td><td></td><td>34</td></tr> <tr><td colspan="2">73</td><td>32</td><td></td><td>30</td><td></td><td>28</td><td>26</td><td></td><td>23</td><td></td><td></td><td></td><td></td><td>19</td><td>18</td><td></td></tr> <tr><td colspan="2"></td><td>16</td><td>15</td><td></td><td></td><td>12</td><td>10</td><td></td><td></td><td></td><td></td><td></td><td></td><td>3</td><td></td><td></td></tr> </table>		71	70	69	67		64	63		60			57	56	55	54	53	52	51		49			45	44	43	42	41			37	36		34	73		32		30		28	26		23					19	18				16	15			12	10							3									
	71	70	69	67		64	63		60			57	56	55	54	53																																																																		
52	51		49			45	44	43	42	41			37	36		34																																																																		
73		32		30		28	26		23					19	18																																																																			
		16	15			12	10							3																																																																				
AVAILABLE	NOT APPLICABLE	34566-4053	G	0	A	BLACK	<table border="1"> <tr><td>72</td><td></td><td>69</td><td>67</td><td>66</td><td>65</td><td>63</td><td></td><td>60</td><td></td><td></td><td>57</td><td>56</td><td></td><td></td><td></td><td></td><td>53</td></tr> <tr><td></td><td></td><td>49</td><td></td><td>47</td><td>46</td><td>44</td><td>43</td><td>42</td><td>40</td><td></td><td>37</td><td>36</td><td>35</td><td></td><td></td><td></td><td>33</td></tr> <tr><td colspan="2">73</td><td>31</td><td>30</td><td>29</td><td>28</td><td>27</td><td>26</td><td>24</td><td></td><td></td><td>21</td><td>20</td><td></td><td></td><td></td><td></td><td>17</td></tr> <tr><td colspan="2"></td><td>16</td><td>15</td><td>14</td><td>13</td><td></td><td>11</td><td>10</td><td></td><td></td><td></td><td>5</td><td>4</td><td>3</td><td>2</td><td>1</td><td></td></tr> </table>	72		69	67	66	65	63		60			57	56					53			49		47	46	44	43	42	40		37	36	35				33	73		31	30	29	28	27	26	24			21	20					17			16	15	14	13		11	10				5	4	3	2	1				
72		69	67	66	65	63		60			57	56					53																																																																	
		49		47	46	44	43	42	40		37	36	35				33																																																																	
73		31	30	29	28	27	26	24			21	20					17																																																																	
		16	15	14	13		11	10				5	4	3	2	1																																																																		
AVAILABLE	NOT APPLICABLE	34566-4063	G	0	B	ST GRAY	<table border="1"> <tr><td></td><td></td><td></td><td>68</td><td>67</td><td></td><td>64</td><td></td><td></td><td></td><td>59</td><td>58</td><td></td><td></td><td></td><td></td><td></td><td>54</td></tr> <tr><td></td><td></td><td></td><td></td><td>46</td><td>45</td><td></td><td></td><td></td><td></td><td>39</td><td>38</td><td></td><td></td><td></td><td></td><td></td><td></td></tr> <tr><td colspan="2">73</td><td>32</td><td></td><td>30</td><td>29</td><td>28</td><td>27</td><td></td><td></td><td>23</td><td>22</td><td></td><td></td><td></td><td></td><td></td><td>17</td></tr> <tr><td colspan="2"></td><td></td><td>15</td><td>14</td><td>13</td><td></td><td>10</td><td>8</td><td></td><td></td><td></td><td></td><td></td><td></td><td></td><td></td><td>1</td></tr> </table>				68	67		64				59	58						54					46	45					39	38							73		32		30	29	28	27			23	22						17				15	14	13		10	8									1			
			68	67		64				59	58						54																																																																	
				46	45					39	38																																																																							
73		32		30	29	28	27			23	22						17																																																																	
			15	14	13		10	8									1																																																																	
AVAILABLE	NOT APPLICABLE	34566-4073	G	0	A	BLACK	<table border="1"> <tr><td>72</td><td>70</td><td></td><td></td><td>66</td><td></td><td>63</td><td>62</td><td></td><td>59</td><td></td><td>57</td><td>56</td><td>55</td><td>53</td></tr> <tr><td>52</td><td>51</td><td></td><td></td><td>46</td><td>44</td><td>42</td><td>40</td><td>39</td><td></td><td>37</td><td>36</td><td></td><td>34</td><td>33</td></tr> <tr><td colspan="2">73</td><td>32</td><td>30</td><td></td><td></td><td>26</td><td>25</td><td></td><td>22</td><td>21</td><td></td><td>19</td><td>18</td><td></td></tr> <tr><td colspan="2"></td><td></td><td>15</td><td>14</td><td></td><td></td><td>10</td><td>9</td><td></td><td>6</td><td></td><td>3</td><td></td><td></td></tr> </table>	72	70			66		63	62		59		57	56	55	53	52	51			46	44	42	40	39		37	36		34	33	73		32	30			26	25		22	21		19	18					15	14			10	9		6		3																	
72	70			66		63	62		59		57	56	55	53																																																																				
52	51			46	44	42	40	39		37	36		34	33																																																																				
73		32	30			26	25		22	21		19	18																																																																					
			15	14			10	9		6		3																																																																						

ENTER DESCRIPTION DEC NO: UAU2013-0662 DRAWN BY: T88 CHKD: T88 APPR: WOSHY 2012/11/21 DESCRIPTION	QUALITY SYMBOLS	GENERAL TOLERANCES (UNLESS SPECIFIED)	DIMENSION STYLE	SCALE	DESIGN UNITS	THIRD ANGLE PROJECTION
	▽=0	mm INCH	MM ONLY		METRIC	
	▽=0	4 PLACES ± --- ± ---	DRAWN BY: SKRA JENDRANA	DATE: 2011/02/14	TITLE:	MX123
	▽=0	3 PLACES ± --- ± ---	CHECKED BY: MVANSLAMBROU	DATE: 2011/02/14		66/73/80CKT
	2 PLACES ± --- ± ---	1 PLACE ± --- ± ---	APPROVED BY:	DATE:		HRNS CONN ASSY
	0 PLACE ± --- ± ---	ANGULAR ± ---°	MATERIAL NO.	DOCUMENT NO.		molex
	DRAFT WHERE APPLICABLE MUST REMAIN WITHIN DIMENSIONS	SEE BOM TABLE				SD-34566-001
						SHEET NO. 47 OF 59

STATUS	GM PART #	MATERIAL #	PART/MATERIAL REVISION	WIRE DRESS OPTION	KEY OPTION	COLOR (TPA)	NUMBERS INDICATE CAVITIES OPEN FOR CIRCUITS																																																																								
AVAILABLE	NOT APPLICABLE	34566-4083	G	0	C	BLUE	<table border="1"> <tr><td>72</td><td>70</td><td>68</td><td></td><td></td><td></td><td>63</td><td>62</td><td></td><td></td><td>59</td><td>58</td><td>57</td><td></td><td></td><td>53</td></tr> <tr><td>52</td><td>51</td><td></td><td>48</td><td>47</td><td></td><td>44</td><td>42</td><td></td><td>40</td><td>39</td><td>38</td><td>37</td><td>36</td><td></td><td>34</td><td>33</td></tr> <tr><td></td><td></td><td></td><td>32</td><td></td><td>30</td><td></td><td></td><td></td><td>27</td><td>26</td><td>25</td><td>24</td><td></td><td>22</td><td>21</td><td>20</td></tr> <tr><td>73</td><td></td><td></td><td>15</td><td>14</td><td>13</td><td></td><td></td><td></td><td></td><td>8</td><td></td><td>6</td><td>5</td><td>4</td><td></td><td>2</td><td>1</td></tr> </table>	72	70	68				63	62			59	58	57			53	52	51		48	47		44	42		40	39	38	37	36		34	33				32		30				27	26	25	24		22	21	20	73			15	14	13					8		6	5	4		2	1				
72	70	68				63	62			59	58	57			53																																																																
52	51		48	47		44	42		40	39	38	37	36		34	33																																																															
			32		30				27	26	25	24		22	21	20																																																															
73			15	14	13					8		6	5	4		2	1																																																														
AVAILABLE	NOT APPLICABLE	34566-4093	G	0	A	BLACK	<table border="1"> <tr><td>71</td><td>70</td><td>69</td><td></td><td>67</td><td></td><td>64</td><td>63</td><td></td><td></td><td>60</td><td></td><td></td><td>57</td><td>56</td><td>55</td><td>54</td><td>53</td></tr> <tr><td>52</td><td>51</td><td></td><td>49</td><td></td><td>47</td><td></td><td>45</td><td>44</td><td>43</td><td>42</td><td>41</td><td></td><td></td><td>37</td><td>36</td><td></td><td>34</td></tr> <tr><td></td><td></td><td></td><td>32</td><td></td><td>30</td><td></td><td></td><td>28</td><td></td><td>26</td><td></td><td></td><td>23</td><td></td><td></td><td>19</td><td>18</td></tr> <tr><td>73</td><td></td><td></td><td>16</td><td>15</td><td></td><td></td><td>12</td><td></td><td>10</td><td></td><td></td><td></td><td></td><td></td><td></td><td>3</td><td></td></tr> </table>	71	70	69		67		64	63			60			57	56	55	54	53	52	51		49		47		45	44	43	42	41			37	36		34				32		30			28		26			23			19	18	73			16	15			12		10							3	
71	70	69		67		64	63			60			57	56	55	54	53																																																														
52	51		49		47		45	44	43	42	41			37	36		34																																																														
			32		30			28		26			23			19	18																																																														
73			16	15			12		10							3																																																															
AVAILABLE	NOT APPLICABLE	34566-4113	G	0	B	ST GRAY	<table border="1"> <tr><td></td><td></td><td></td><td>68</td><td>67</td><td></td><td>64</td><td></td><td></td><td></td><td></td><td></td><td></td><td>58</td><td></td><td></td><td></td><td></td></tr> <tr><td></td><td></td><td></td><td></td><td></td><td>46</td><td>45</td><td></td><td></td><td></td><td></td><td></td><td></td><td>38</td><td></td><td></td><td></td><td></td></tr> <tr><td></td><td></td><td></td><td>32</td><td></td><td>30</td><td>29</td><td>28</td><td>27</td><td></td><td></td><td></td><td></td><td>22</td><td></td><td></td><td></td><td>17</td></tr> <tr><td>73</td><td></td><td></td><td>15</td><td></td><td>13</td><td></td><td></td><td>10</td><td></td><td></td><td></td><td></td><td></td><td></td><td></td><td></td><td>1</td></tr> </table>				68	67		64							58										46	45							38								32		30	29	28	27					22				17	73			15		13			10									1
			68	67		64							58																																																																		
					46	45							38																																																																		
			32		30	29	28	27					22				17																																																														
73			15		13			10									1																																																														
AVAILABLE	NOT APPLICABLE	34566-4123	G	9	A	BLACK	<table border="1"> <tr><td>72</td><td></td><td>69</td><td></td><td>67</td><td>66</td><td>65</td><td></td><td>63</td><td></td><td>60</td><td></td><td></td><td>57</td><td>56</td><td></td><td></td><td>53</td></tr> <tr><td></td><td></td><td>49</td><td></td><td>47</td><td>46</td><td></td><td>44</td><td>43</td><td>42</td><td>40</td><td></td><td></td><td>37</td><td>36</td><td>35</td><td></td><td>33</td></tr> <tr><td></td><td></td><td></td><td>31</td><td>30</td><td>29</td><td>28</td><td></td><td>26</td><td></td><td>24</td><td></td><td></td><td>21</td><td>20</td><td></td><td></td><td>17</td></tr> <tr><td>73</td><td></td><td></td><td>16</td><td>15</td><td>14</td><td>13</td><td></td><td>11</td><td>10</td><td></td><td></td><td></td><td>5</td><td>4</td><td>3</td><td>2</td><td>1</td></tr> </table>	72		69		67	66	65		63		60			57	56			53			49		47	46		44	43	42	40			37	36	35		33				31	30	29	28		26		24			21	20			17	73			16	15	14	13		11	10				5	4	3	2	1
72		69		67	66	65		63		60			57	56			53																																																														
		49		47	46		44	43	42	40			37	36	35		33																																																														
			31	30	29	28		26		24			21	20			17																																																														
73			16	15	14	13		11	10				5	4	3	2	1																																																														
AVAILABLE	NOT APPLICABLE	34566-4133	G	9	B	ST GRAY	<table border="1"> <tr><td></td><td></td><td></td><td>68</td><td>67</td><td></td><td>64</td><td></td><td></td><td></td><td></td><td></td><td>59</td><td>58</td><td></td><td></td><td></td><td>54</td></tr> <tr><td></td><td></td><td></td><td></td><td></td><td>46</td><td>45</td><td></td><td></td><td></td><td></td><td></td><td>39</td><td>38</td><td></td><td></td><td></td><td></td></tr> <tr><td></td><td></td><td></td><td>32</td><td></td><td>30</td><td>29</td><td>28</td><td>27</td><td></td><td></td><td></td><td>23</td><td>22</td><td></td><td></td><td></td><td>17</td></tr> <tr><td>73</td><td></td><td></td><td>15</td><td></td><td>13</td><td></td><td></td><td>10</td><td>9</td><td>8</td><td></td><td></td><td></td><td></td><td></td><td></td><td>1</td></tr> </table>				68	67		64						59	58				54						46	45						39	38								32		30	29	28	27				23	22				17	73			15		13			10	9	8							1
			68	67		64						59	58				54																																																														
					46	45						39	38																																																																		
			32		30	29	28	27				23	22				17																																																														
73			15		13			10	9	8							1																																																														
AVAILABLE	NOT APPLICABLE	34566-4143	G	0	B	ST GRAY	<table border="1"> <tr><td></td><td></td><td></td><td>68</td><td>67</td><td></td><td>64</td><td></td><td></td><td></td><td></td><td></td><td>59</td><td>58</td><td></td><td></td><td></td><td>54</td></tr> <tr><td></td><td></td><td></td><td></td><td></td><td>46</td><td>45</td><td></td><td></td><td></td><td></td><td></td><td>39</td><td>38</td><td></td><td></td><td></td><td></td></tr> <tr><td></td><td></td><td></td><td>32</td><td></td><td>30</td><td>29</td><td>28</td><td>27</td><td></td><td></td><td></td><td>23</td><td>22</td><td></td><td></td><td></td><td>17</td></tr> <tr><td>73</td><td></td><td></td><td></td><td></td><td></td><td></td><td></td><td>10</td><td>9</td><td></td><td></td><td></td><td></td><td></td><td></td><td></td><td>1</td></tr> </table>				68	67		64						59	58				54						46	45						39	38								32		30	29	28	27				23	22				17	73								10	9								1
			68	67		64						59	58				54																																																														
					46	45						39	38																																																																		
			32		30	29	28	27				23	22				17																																																														
73								10	9								1																																																														
AVAILABLE	NOT APPLICABLE	34566-4153	G	0	B	ST GRAY	<table border="1"> <tr><td>72</td><td>70</td><td>68</td><td></td><td>66</td><td></td><td></td><td></td><td></td><td></td><td>60</td><td>59</td><td></td><td></td><td></td><td>55</td><td>54</td><td>53</td></tr> <tr><td>52</td><td>50</td><td></td><td>48</td><td>46</td><td></td><td>44</td><td></td><td></td><td></td><td>40</td><td>39</td><td></td><td></td><td></td><td>35</td><td>34</td><td>33</td></tr> <tr><td></td><td></td><td></td><td>32</td><td>31</td><td>30</td><td>29</td><td>28</td><td>27</td><td>26</td><td>25</td><td>24</td><td>23</td><td></td><td></td><td>19</td><td>18</td><td></td></tr> <tr><td></td><td></td><td></td><td>16</td><td></td><td></td><td></td><td></td><td>10</td><td>9</td><td>8</td><td>7</td><td></td><td></td><td></td><td></td><td></td><td></td></tr> </table>	72	70	68		66						60	59				55	54	53	52	50		48	46		44				40	39				35	34	33				32	31	30	29	28	27	26	25	24	23			19	18					16					10	9	8	7						
72	70	68		66						60	59				55	54	53																																																														
52	50		48	46		44				40	39				35	34	33																																																														
			32	31	30	29	28	27	26	25	24	23			19	18																																																															
			16					10	9	8	7																																																																				
AVAILABLE	NOT APPLICABLE	34566-4163	G	0	B	ST GRAY	<table border="1"> <tr><td>72</td><td>70</td><td>68</td><td></td><td>66</td><td></td><td></td><td></td><td></td><td></td><td>60</td><td>59</td><td></td><td></td><td></td><td>55</td><td>54</td><td>53</td></tr> <tr><td>52</td><td>50</td><td></td><td>48</td><td>46</td><td></td><td>44</td><td></td><td></td><td></td><td>40</td><td>39</td><td></td><td></td><td></td><td>35</td><td>34</td><td>33</td></tr> <tr><td></td><td></td><td></td><td>32</td><td>31</td><td>30</td><td>29</td><td>28</td><td>27</td><td>26</td><td>25</td><td>24</td><td>23</td><td></td><td></td><td>19</td><td>18</td><td></td></tr> <tr><td></td><td></td><td></td><td>16</td><td></td><td></td><td></td><td></td><td>10</td><td>9</td><td>8</td><td>7</td><td></td><td></td><td></td><td></td><td></td><td>1</td></tr> </table>	72	70	68		66						60	59				55	54	53	52	50		48	46		44				40	39				35	34	33				32	31	30	29	28	27	26	25	24	23			19	18					16					10	9	8	7						1
72	70	68		66						60	59				55	54	53																																																														
52	50		48	46		44				40	39				35	34	33																																																														
			32	31	30	29	28	27	26	25	24	23			19	18																																																															
			16					10	9	8	7						1																																																														
AVAILABLE	NOT APPLICABLE	34566-4173	G	0	A	BLACK	<table border="1"> <tr><td>72</td><td>71</td><td>70</td><td>69</td><td></td><td></td><td>64</td><td>63</td><td></td><td></td><td>60</td><td>59</td><td>58</td><td></td><td>56</td><td>55</td><td>54</td><td>53</td></tr> <tr><td>52</td><td>51</td><td></td><td>49</td><td></td><td>47</td><td></td><td>45</td><td>44</td><td>43</td><td>42</td><td>41</td><td></td><td></td><td>38</td><td></td><td>36</td><td>34</td></tr> <tr><td></td><td></td><td></td><td>32</td><td></td><td>30</td><td></td><td></td><td>28</td><td></td><td>26</td><td>25</td><td></td><td></td><td>21</td><td></td><td>19</td><td>18</td></tr> <tr><td></td><td></td><td></td><td>16</td><td>15</td><td></td><td></td><td>12</td><td></td><td>10</td><td>9</td><td>8</td><td></td><td></td><td>5</td><td></td><td>3</td><td></td></tr> </table>	72	71	70	69			64	63			60	59	58		56	55	54	53	52	51		49		47		45	44	43	42	41			38		36	34				32		30			28		26	25			21		19	18				16	15			12		10	9	8			5		3	
72	71	70	69			64	63			60	59	58		56	55	54	53																																																														
52	51		49		47		45	44	43	42	41			38		36	34																																																														
			32		30			28		26	25			21		19	18																																																														
			16	15			12		10	9	8			5		3																																																															

ENTER DESCRIPTION EC NO: UAU2013-0662 DRAWN BY: CHKD APPR: IKOSHY 2012/11/21	QUALITY SYMBOLS	GENERAL TOLERANCES (UNLESS SPECIFIED)	DIMENSION STYLE	SCALE	DESIGN UNITS	THIRD ANGLE PROJECTION	
	∇=0 ∇=0 ∇=0	mm INCH 4 PLACES #--- #--- 3 PLACES #--- #--- 2 PLACES #--- #--- 1 PLACE #--- #--- 0 PLACE #--- #---	MM ONLY	DRAWN BY: SKRAJENDRANA DATE: 2011/02/14 CHECKED BY: MYANSLAMBROU DATE: 2011/02/14 APPROVED BY:	METRIC		
	ANGULAR ±---° DRAFT WHERE APPLICABLE MUST REMAIN WITHIN DIMENSIONS	MATERIAL NO. DOCUMENT NO.	TITLE MX123 66/73/80CKT HRNS CONN ASSY molex SD-34566-001	SHEET NO. 48 OF 59			
	THIS DRAWING CONTAINS INFORMATION THAT IS PROPRIETARY TO MOLEX INCORPORATED AND SHOULD NOT BE USED WITHOUT WRITTEN PERMISSION						

STATUS	GM PART #	MATERIAL #	PART/MATERIAL REVISION	WIRE DRESS OPTION	KEY OPTION	COLOR (TPA)	NUMBERS INDICATE CAVITIES OPEN FOR CIRCUITS																																																																																																			
							<table border="1"> <tr> <td>72</td><td>70</td><td>68</td><td>66</td><td></td><td>63</td><td>62</td><td></td><td>59</td><td>58</td><td>57</td><td></td><td></td><td></td><td></td><td></td><td></td><td></td><td></td><td></td><td>53</td> </tr> <tr> <td>52</td><td>51</td><td>48</td><td>47</td><td>46</td><td>44</td><td>42</td><td>40</td><td>39</td><td></td><td></td><td></td><td></td><td></td><td></td><td></td><td></td><td></td><td></td><td></td><td>34</td><td>33</td> </tr> <tr> <td colspan="2">73</td><td></td><td>32</td><td>30</td><td></td><td></td><td>26</td><td>25</td><td>23</td><td>22</td><td>21</td><td>20</td><td></td><td></td><td></td><td></td><td></td><td></td><td></td><td></td><td>17</td> </tr> <tr> <td></td><td></td><td></td><td>15</td><td>14</td><td>13</td><td></td><td></td><td>10</td><td>9</td><td>7</td><td>6</td><td>5</td><td>4</td><td></td><td></td><td></td><td></td><td></td><td></td><td></td><td>1</td> </tr> </table>																				72	70	68	66		63	62		59	58	57										53	52	51	48	47	46	44	42	40	39												34	33	73			32	30			26	25	23	22	21	20									17				15	14	13			10	9	7	6	5	4	
72	70	68	66		63	62		59	58	57										53																																																																																						
52	51	48	47	46	44	42	40	39												34	33																																																																																					
73			32	30			26	25	23	22	21	20									17																																																																																					
			15	14	13			10	9	7	6	5	4								1																																																																																					
AVAILABLE	NOT APPLICABLE	34566-4183	G	0	C	BLUE																																																																																																				
AVAILABLE	NOT APPLICABLE	34566-4193	G	0	C	BLUE																																																																																																				
AVAILABLE	NOT APPLICABLE	34566-4213	G	0	A	BLACK																																																																																																				
AVAILABLE	NOT APPLICABLE	34566-4223	G	0	A	BLACK																																																																																																				
AVAILABLE	NOT APPLICABLE	34566-4233	G	0	B	ST GRAY																																																																																																				
AVAILABLE	NOT APPLICABLE	34566-4243	G	0	A	BLACK																																																																																																				
AVAILABLE	NOT APPLICABLE	34566-4253	G	0	A	BLACK																																																																																																				
AVAILABLE	NOT APPLICABLE	34566-4263	G	0	B	ST GRAY																																																																																																				
AVAILABLE	NOT APPLICABLE	34566-4273	G	0	B	ST GRAY																																																																																																				

ENTER DESCRIPTION EC NO: UAU2013-0662 DRAWN BY: CHKO. APPR: IKOSHY 2012/11/01 2012/11/21	QUALITY SYMBOLS ∇=0 ∇=0 ∇=0	GENERAL TOLERANCES (UNLESS SPECIFIED) <table border="1"> <tr> <th></th> <th>mm</th> <th>INCH</th> </tr> <tr> <td>4 PLACES</td> <td>±---</td> <td>±---</td> </tr> <tr> <td>3 PLACES</td> <td>±---</td> <td>±---</td> </tr> <tr> <td>2 PLACES</td> <td>±---</td> <td>±---</td> </tr> <tr> <td>1 PLACE</td> <td>±---</td> <td>±---</td> </tr> <tr> <td>0 PLACE</td> <td>±---</td> <td>±---</td> </tr> </table>		mm	INCH	4 PLACES	±---	±---	3 PLACES	±---	±---	2 PLACES	±---	±---	1 PLACE	±---	±---	0 PLACE	±---	±---	DIMENSION STYLE MM ONLY	SCALE METRIC	DESIGN UNITS METRIC	THIRD ANGLE PROJECTION
		mm	INCH																					
	4 PLACES	±---	±---																					
	3 PLACES	±---	±---																					
2 PLACES	±---	±---																						
1 PLACE	±---	±---																						
0 PLACE	±---	±---																						
DRAWN BY: SKRA JENDRANA 2011/02/14 CHECKED BY: MYANSLAMBROU 2011/02/14 APPROVED BY:	DATE:	DATE:	DATE:	DATE:	TITLE MX123 66/73/80CKT HRNS CONN ASSY	SHEET NO. 49 OF 59																		
MATERIAL NO. SEE BOM TABLE	DOCUMENT NO. SD-34566-001	THIS DRAWING CONTAINS INFORMATION THAT IS PROPRIETARY TO MOLEX INCORPORATED AND SHOULD NOT BE USED WITHOUT WRITTEN PERMISSION																						

STATUS	GM PART #	MATERIAL #	PART/MATERIAL REVISION	WIRE DRESS OPTION	KEY OPTION	COLOR (TPA)	NUMBERS INDICATE CAVITIES OPEN FOR CIRCUITS																																																																																											
AVAILABLE	NOT APPLICABLE	34566-4283	G	0	A	BLACK	<table border="1"> <tr><td></td><td>70</td><td>69</td><td></td><td></td><td></td><td></td><td></td><td>63</td><td>62</td><td>61</td><td>60</td><td></td><td></td><td>57</td><td>56</td><td>55</td><td>54</td><td>53</td></tr> <tr><td>52</td><td>51</td><td>49</td><td></td><td></td><td></td><td></td><td></td><td>44</td><td>43</td><td>42</td><td>41</td><td></td><td></td><td></td><td>37</td><td>36</td><td></td><td>34</td></tr> <tr><td></td><td></td><td></td><td>32</td><td></td><td></td><td></td><td></td><td>29</td><td>28</td><td>27</td><td>26</td><td></td><td></td><td>23</td><td></td><td></td><td></td><td>19</td><td>18</td></tr> <tr><td></td><td></td><td></td><td>16</td><td>15</td><td>14</td><td>13</td><td>12</td><td>11</td><td>10</td><td></td><td></td><td>8</td><td></td><td></td><td></td><td></td><td></td><td>3</td><td></td></tr> </table>		70	69						63	62	61	60			57	56	55	54	53	52	51	49						44	43	42	41				37	36		34				32					29	28	27	26			23				19	18				16	15	14	13	12	11	10			8						3														
	70	69						63	62	61	60			57	56	55	54	53																																																																																
52	51	49						44	43	42	41				37	36		34																																																																																
			32					29	28	27	26			23				19	18																																																																															
			16	15	14	13	12	11	10			8						3																																																																																
AVAILABLE	NOT APPLICABLE	34566-4293	G	0	B	ST GRAY	<table border="1"> <tr><td></td><td></td><td></td><td></td><td>67</td><td>66</td><td></td><td></td><td></td><td>63</td><td></td><td></td><td></td><td></td><td>59</td><td>58</td><td>57</td><td>56</td><td>55</td><td>54</td><td>53</td></tr> <tr><td></td><td></td><td>50</td><td>49</td><td>48</td><td></td><td></td><td></td><td>45</td><td>43</td><td></td><td></td><td></td><td></td><td>39</td><td>38</td><td>37</td><td>36</td><td>35</td><td>34</td><td>33</td></tr> <tr><td></td><td></td><td></td><td></td><td></td><td></td><td></td><td></td><td>29</td><td>27</td><td></td><td></td><td></td><td></td><td>23</td><td>22</td><td>21</td><td></td><td></td><td></td><td>18</td></tr> <tr><td></td><td></td><td></td><td></td><td></td><td></td><td></td><td></td><td>16</td><td>15</td><td>14</td><td>13</td><td></td><td></td><td>8</td><td>7</td><td>6</td><td>5</td><td>4</td><td>3</td><td></td></tr> </table>					67	66				63					59	58	57	56	55	54	53			50	49	48				45	43					39	38	37	36	35	34	33									29	27					23	22	21				18									16	15	14	13			8	7	6	5	4	3								
				67	66				63					59	58	57	56	55	54	53																																																																														
		50	49	48				45	43					39	38	37	36	35	34	33																																																																														
								29	27					23	22	21				18																																																																														
								16	15	14	13			8	7	6	5	4	3																																																																															
AVAILABLE	NOT APPLICABLE	34566-4313	G	0	B	ST GRAY	<table border="1"> <tr><td></td><td></td><td></td><td></td><td></td><td></td><td></td><td></td><td></td><td>63</td><td></td><td></td><td></td><td></td><td>59</td><td>58</td><td>57</td><td>56</td><td>55</td><td>54</td><td>53</td></tr> <tr><td></td><td></td><td>50</td><td>49</td><td>48</td><td></td><td></td><td></td><td>46</td><td>43</td><td></td><td></td><td></td><td></td><td>39</td><td>38</td><td>37</td><td>36</td><td>35</td><td>34</td><td>33</td></tr> <tr><td></td><td></td><td></td><td></td><td></td><td></td><td></td><td></td><td>29</td><td>27</td><td></td><td></td><td></td><td></td><td>23</td><td>22</td><td>21</td><td></td><td></td><td></td><td>18</td></tr> <tr><td></td><td></td><td></td><td></td><td></td><td></td><td></td><td></td><td>16</td><td>15</td><td>14</td><td>13</td><td></td><td></td><td>7</td><td>6</td><td>5</td><td>4</td><td>3</td><td></td><td></td></tr> </table>										63					59	58	57	56	55	54	53			50	49	48				46	43					39	38	37	36	35	34	33									29	27					23	22	21				18									16	15	14	13			7	6	5	4	3									
									63					59	58	57	56	55	54	53																																																																														
		50	49	48				46	43					39	38	37	36	35	34	33																																																																														
								29	27					23	22	21				18																																																																														
								16	15	14	13			7	6	5	4	3																																																																																
AVAILABLE	NOT APPLICABLE	34566-4323	G	0	B	ST GRAY	<table border="1"> <tr><td>72</td><td>70</td><td>68</td><td></td><td>66</td><td></td><td></td><td></td><td></td><td></td><td></td><td></td><td>60</td><td>59</td><td></td><td></td><td></td><td></td><td>55</td><td>54</td><td>53</td></tr> <tr><td>52</td><td>51</td><td>48</td><td></td><td>46</td><td></td><td></td><td></td><td></td><td></td><td></td><td></td><td>40</td><td>39</td><td></td><td></td><td></td><td></td><td></td><td>35</td><td>34</td><td>33</td></tr> <tr><td></td><td></td><td></td><td>32</td><td>31</td><td>30</td><td>29</td><td>28</td><td>27</td><td>26</td><td>25</td><td>24</td><td></td><td></td><td></td><td></td><td></td><td></td><td></td><td>19</td><td>18</td><td>17</td></tr> <tr><td></td><td></td><td></td><td>16</td><td></td><td></td><td></td><td></td><td></td><td></td><td></td><td>10</td><td>8</td><td>7</td><td></td><td></td><td></td><td></td><td></td><td></td><td></td><td>2</td><td>1</td></tr> </table>	72	70	68		66								60	59					55	54	53	52	51	48		46								40	39						35	34	33				32	31	30	29	28	27	26	25	24								19	18	17				16								10	8	7								2	1			
72	70	68		66								60	59					55	54	53																																																																														
52	51	48		46								40	39						35	34	33																																																																													
			32	31	30	29	28	27	26	25	24								19	18	17																																																																													
			16								10	8	7								2	1																																																																												
AVAILABLE	NOT APPLICABLE	34566-4333	G	0	A	BLACK	<table border="1"> <tr><td>72</td><td>71</td><td>70</td><td>69</td><td></td><td>67</td><td></td><td></td><td></td><td>64</td><td>63</td><td></td><td></td><td>60</td><td>59</td><td></td><td></td><td></td><td>56</td><td>55</td><td>54</td><td>53</td></tr> <tr><td>52</td><td>51</td><td>49</td><td></td><td></td><td>47</td><td></td><td></td><td>45</td><td>44</td><td>43</td><td>42</td><td>41</td><td></td><td></td><td>38</td><td></td><td></td><td>36</td><td></td><td>34</td><td></td></tr> <tr><td></td><td></td><td></td><td></td><td>32</td><td></td><td>30</td><td></td><td></td><td>28</td><td>26</td><td>25</td><td></td><td></td><td>23</td><td></td><td></td><td></td><td></td><td>19</td><td>18</td><td></td></tr> <tr><td></td><td></td><td></td><td></td><td>16</td><td>15</td><td></td><td></td><td></td><td>12</td><td>10</td><td>9</td><td></td><td></td><td></td><td></td><td></td><td></td><td></td><td></td><td>3</td><td></td></tr> </table>	72	71	70	69		67				64	63			60	59				56	55	54	53	52	51	49			47			45	44	43	42	41			38			36		34						32		30			28	26	25			23					19	18						16	15				12	10	9									3				
72	71	70	69		67				64	63			60	59				56	55	54	53																																																																													
52	51	49			47			45	44	43	42	41			38			36		34																																																																														
				32		30			28	26	25			23					19	18																																																																														
				16	15				12	10	9									3																																																																														
AVAILABLE	NOT APPLICABLE	34566-4343	G	0	A	BLACK	<table border="1"> <tr><td>72</td><td>71</td><td>70</td><td>69</td><td></td><td></td><td></td><td></td><td></td><td>64</td><td>63</td><td></td><td></td><td>60</td><td>59</td><td>58</td><td></td><td></td><td>56</td><td>55</td><td>54</td><td>53</td></tr> <tr><td>52</td><td>51</td><td>49</td><td></td><td></td><td>47</td><td></td><td></td><td>45</td><td>44</td><td>43</td><td>42</td><td>41</td><td></td><td></td><td>38</td><td></td><td></td><td>36</td><td></td><td>34</td><td></td></tr> <tr><td></td><td></td><td></td><td></td><td>32</td><td></td><td>30</td><td></td><td></td><td>28</td><td>26</td><td>25</td><td></td><td></td><td></td><td></td><td></td><td></td><td></td><td>19</td><td>18</td><td></td></tr> <tr><td></td><td></td><td></td><td></td><td>16</td><td>15</td><td></td><td></td><td></td><td>12</td><td>10</td><td>9</td><td></td><td></td><td></td><td></td><td></td><td></td><td></td><td></td><td>3</td><td></td></tr> </table>	72	71	70	69						64	63			60	59	58			56	55	54	53	52	51	49			47			45	44	43	42	41			38			36		34						32		30			28	26	25								19	18						16	15				12	10	9									3				
72	71	70	69						64	63			60	59	58			56	55	54	53																																																																													
52	51	49			47			45	44	43	42	41			38			36		34																																																																														
				32		30			28	26	25								19	18																																																																														
				16	15				12	10	9									3																																																																														
AVAILABLE	NOT APPLICABLE	34566-4353	G	0	C	BLUE	<table border="1"> <tr><td>72</td><td>70</td><td>68</td><td></td><td></td><td></td><td></td><td></td><td></td><td>63</td><td>62</td><td></td><td></td><td>59</td><td>58</td><td>57</td><td></td><td></td><td></td><td></td><td></td><td>53</td></tr> <tr><td>52</td><td>51</td><td></td><td>48</td><td>47</td><td></td><td></td><td></td><td>44</td><td>42</td><td>40</td><td>39</td><td></td><td></td><td></td><td></td><td></td><td></td><td></td><td></td><td></td><td>34</td><td>33</td></tr> <tr><td></td><td></td><td></td><td>32</td><td></td><td>30</td><td></td><td></td><td></td><td>26</td><td>25</td><td></td><td></td><td>23</td><td>22</td><td>21</td><td>20</td><td></td><td></td><td></td><td></td><td>17</td><td></td></tr> <tr><td></td><td></td><td></td><td></td><td></td><td>15</td><td>14</td><td>13</td><td></td><td></td><td></td><td></td><td></td><td>7</td><td>6</td><td>5</td><td>4</td><td></td><td></td><td></td><td></td><td></td><td>1</td></tr> </table>	72	70	68							63	62			59	58	57						53	52	51		48	47				44	42	40	39										34	33				32		30				26	25			23	22	21	20					17							15	14	13						7	6	5	4						1
72	70	68							63	62			59	58	57						53																																																																													
52	51		48	47				44	42	40	39										34	33																																																																												
			32		30				26	25			23	22	21	20					17																																																																													
					15	14	13						7	6	5	4						1																																																																												
AVAILABLE	NOT APPLICABLE	34566-4363	G	0	A	BLACK	<table border="1"> <tr><td></td><td>70</td><td>69</td><td></td><td></td><td></td><td></td><td></td><td></td><td>63</td><td>62</td><td>61</td><td>60</td><td></td><td></td><td>58</td><td>57</td><td>56</td><td>55</td><td>54</td><td>53</td></tr> <tr><td>52</td><td>51</td><td>49</td><td></td><td></td><td></td><td></td><td></td><td></td><td>44</td><td>43</td><td>42</td><td>41</td><td></td><td></td><td></td><td>37</td><td>36</td><td></td><td>34</td><td></td></tr> <tr><td></td><td></td><td></td><td>32</td><td></td><td></td><td></td><td></td><td></td><td>29</td><td>28</td><td>27</td><td>26</td><td></td><td></td><td>23</td><td></td><td></td><td></td><td></td><td>19</td><td>18</td></tr> <tr><td></td><td></td><td></td><td>16</td><td>15</td><td>14</td><td>13</td><td>12</td><td>11</td><td>10</td><td></td><td></td><td>8</td><td></td><td></td><td></td><td></td><td></td><td></td><td></td><td>3</td><td></td></tr> </table>		70	69							63	62	61	60			58	57	56	55	54	53	52	51	49							44	43	42	41				37	36		34					32						29	28	27	26			23					19	18				16	15	14	13	12	11	10			8								3						
	70	69							63	62	61	60			58	57	56	55	54	53																																																																														
52	51	49							44	43	42	41				37	36		34																																																																															
			32						29	28	27	26			23					19	18																																																																													
			16	15	14	13	12	11	10			8								3																																																																														
AVAILABLE	NOT APPLICABLE	34566-4373	G	0	A	BLACK	<table border="1"> <tr><td></td><td>70</td><td>69</td><td></td><td></td><td></td><td></td><td></td><td></td><td>63</td><td></td><td></td><td></td><td></td><td></td><td>58</td><td></td><td></td><td></td><td>56</td><td></td><td>54</td></tr> <tr><td>52</td><td>51</td><td>49</td><td></td><td></td><td></td><td></td><td></td><td></td><td>44</td><td>43</td><td>42</td><td>41</td><td>40</td><td></td><td></td><td></td><td></td><td></td><td>36</td><td></td><td>34</td></tr> <tr><td></td><td></td><td></td><td>32</td><td></td><td></td><td></td><td></td><td></td><td>28</td><td>26</td><td></td><td></td><td></td><td></td><td></td><td></td><td></td><td></td><td></td><td>19</td><td>18</td><td>17</td></tr> <tr><td></td><td></td><td></td><td>16</td><td></td><td></td><td></td><td></td><td></td><td>12</td><td>10</td><td></td><td></td><td></td><td></td><td></td><td></td><td></td><td></td><td></td><td>3</td><td>2</td><td>1</td></tr> </table>		70	69							63						58				56		54	52	51	49							44	43	42	41	40						36		34				32						28	26										19	18	17				16						12	10										3	2	1	
	70	69							63						58				56		54																																																																													
52	51	49							44	43	42	41	40						36		34																																																																													
			32						28	26										19	18	17																																																																												
			16						12	10										3	2	1																																																																												

ENTER DESCRIPTION EC NO: UAU2013-0662 DRAWN BY: 2012/11/01 CHKD: 2012/11/21 APPR: IKOSHY	QUALITY SYMBOLS	GENERAL TOLERANCES (UNLESS SPECIFIED)	DIMENSION STYLE	SCALE	DESIGN UNITS	THIRD ANGLE PROJECTION
	∇=0 ∇=0 ∇=0	mm INCH 4 PLACES #--- #--- 3 PLACES #--- #--- 2 PLACES #--- #--- 1 PLACE #--- #--- 0 PLACE #--- #---	MM ONLY	MM ONLY	METRIC	
	ANGULAR ±---° DRAFT WHERE APPLICABLE MUST REMAIN WITHIN DIMENSIONS	DRAWN BY: SKRAJENDRANA 2011/02/14 CHECKED BY: MVANSLAMBROU 2011/02/14 APPROVED BY:	TITLE	MX123 66/73/80CKT HRNS CONN ASSY		
	MATERIAL NO. DOCUMENT NO.	SEE BOM TABLE	SD-34566-001			SHEET NO. 50 OF 59

STATUS	GM PART #	MATERIAL #	PART/MATERIAL REVISION	WIRE DRESS OPTION	KEY OPTION	COLOR (TPA)	NUMBERS INDICATE CAVITIES OPEN FOR CIRCUITS																																																																																										
AVAILABLE	NOT APPLICABLE	34566-4383	G	0	H	ST GRY	<table border="1"> <tr><td></td><td>79</td><td></td><td></td><td></td><td>74</td><td>73</td><td>72</td><td>71</td><td></td><td>69</td><td>68</td><td>67</td><td></td><td></td><td>64</td><td></td><td>62</td><td>61</td></tr> <tr><td></td><td>59</td><td></td><td></td><td></td><td>54</td><td></td><td>52</td><td></td><td></td><td>49</td><td>48</td><td>47</td><td></td><td></td><td></td><td></td><td>42</td><td>41</td></tr> <tr><td></td><td></td><td>38</td><td></td><td></td><td></td><td></td><td>33</td><td></td><td></td><td>29</td><td></td><td>27</td><td></td><td></td><td>25</td><td></td><td></td><td></td></tr> <tr><td></td><td></td><td></td><td>18</td><td></td><td>15</td><td>14</td><td></td><td></td><td>11</td><td>10</td><td>9</td><td>8</td><td>7</td><td></td><td></td><td></td><td></td><td></td></tr> </table>		79				74	73	72	71		69	68	67			64		62	61		59				54		52			49	48	47					42	41			38					33			29		27			25							18		15	14			11	10	9	8	7																			
	79				74	73	72	71		69	68	67			64		62	61																																																																															
	59				54		52			49	48	47					42	41																																																																															
		38					33			29		27			25																																																																																		
			18		15	14			11	10	9	8	7																																																																																				
AVAILABLE	NOT APPLICABLE	34566-4393	G	0	G	BLUE	<table border="1"> <tr><td></td><td></td><td>78</td><td>77</td><td></td><td>75</td><td>74</td><td></td><td>72</td><td></td><td>70</td><td>69</td><td></td><td>67</td><td></td><td>65</td><td>64</td><td>63</td><td>62</td></tr> <tr><td>60</td><td></td><td>58</td><td>57</td><td></td><td>55</td><td>54</td><td></td><td>52</td><td>51</td><td>50</td><td>49</td><td></td><td>47</td><td></td><td>45</td><td></td><td></td><td></td></tr> <tr><td>40</td><td></td><td>38</td><td>37</td><td></td><td></td><td></td><td></td><td>33</td><td>32</td><td>31</td><td></td><td></td><td>27</td><td>26</td><td>25</td><td>24</td><td></td><td></td></tr> <tr><td>20</td><td></td><td>18</td><td>17</td><td></td><td></td><td></td><td></td><td></td><td></td><td>10</td><td>9</td><td>8</td><td></td><td>6</td><td>5</td><td></td><td>3</td><td>2</td><td>1</td></tr> </table>			78	77		75	74		72		70	69		67		65	64	63	62	60		58	57		55	54		52	51	50	49		47		45				40		38	37					33	32	31			27	26	25	24			20		18	17							10	9	8		6	5		3	2	1													
		78	77		75	74		72		70	69		67		65	64	63	62																																																																															
60		58	57		55	54		52	51	50	49		47		45																																																																																		
40		38	37					33	32	31			27	26	25	24																																																																																	
20		18	17							10	9	8		6	5		3	2	1																																																																														
AVAILABLE	NOT APPLICABLE	34566-4413	G	0	B	ST GRY	<table border="1"> <tr><td></td><td></td><td></td><td></td><td></td><td></td><td></td><td></td><td></td><td>63</td><td></td><td></td><td>59</td><td>58</td><td>57</td><td>56</td><td>55</td><td></td><td>53</td></tr> <tr><td></td><td></td><td>50</td><td>49</td><td>48</td><td></td><td>46</td><td></td><td>43</td><td></td><td></td><td></td><td>39</td><td>38</td><td>37</td><td>36</td><td>35</td><td>34</td><td>33</td></tr> <tr><td></td><td></td><td></td><td></td><td></td><td></td><td></td><td>29</td><td>27</td><td></td><td></td><td></td><td>23</td><td>22</td><td>21</td><td></td><td></td><td>18</td><td></td></tr> <tr><td></td><td>73</td><td></td><td></td><td></td><td>16</td><td>15</td><td>14</td><td></td><td></td><td></td><td></td><td>7</td><td>6</td><td>5</td><td>4</td><td>3</td><td></td><td></td></tr> </table>										63			59	58	57	56	55		53			50	49	48		46		43				39	38	37	36	35	34	33								29	27				23	22	21			18			73				16	15	14					7	6	5	4	3																
									63			59	58	57	56	55		53																																																																															
		50	49	48		46		43				39	38	37	36	35	34	33																																																																															
							29	27				23	22	21			18																																																																																
	73				16	15	14					7	6	5	4	3																																																																																	
AVAILABLE	NOT APPLICABLE	34566-4423	G	9	C	BLUE	<table border="1"> <tr><td>72</td><td>70</td><td></td><td>68</td><td>67</td><td>66</td><td></td><td></td><td>63</td><td>62</td><td></td><td></td><td>59</td><td></td><td>57</td><td></td><td></td><td></td><td>53</td></tr> <tr><td>52</td><td>51</td><td></td><td>48</td><td>47</td><td>46</td><td></td><td>44</td><td>43</td><td>42</td><td></td><td>40</td><td>39</td><td>38</td><td>37</td><td>36</td><td></td><td></td><td>34</td><td>33</td></tr> <tr><td></td><td></td><td></td><td>32</td><td></td><td>30</td><td></td><td></td><td>27</td><td>26</td><td>25</td><td>24</td><td></td><td>22</td><td>21</td><td></td><td></td><td></td><td></td><td></td></tr> <tr><td></td><td>73</td><td></td><td></td><td>15</td><td>14</td><td></td><td></td><td></td><td>10</td><td>9</td><td>8</td><td></td><td>6</td><td>5</td><td>4</td><td></td><td></td><td>2</td><td></td></tr> </table>	72	70		68	67	66			63	62			59		57				53	52	51		48	47	46		44	43	42		40	39	38	37	36			34	33				32		30			27	26	25	24		22	21							73			15	14				10	9	8		6	5	4			2												
72	70		68	67	66			63	62			59		57				53																																																																															
52	51		48	47	46		44	43	42		40	39	38	37	36			34	33																																																																														
			32		30			27	26	25	24		22	21																																																																																			
	73			15	14				10	9	8		6	5	4			2																																																																															
AVAILABLE	NOT APPLICABLE	34566-4433	G	9	A	BLACK	<table border="1"> <tr><td></td><td></td><td>70</td><td>69</td><td></td><td></td><td></td><td></td><td></td><td>63</td><td>62</td><td>61</td><td>60</td><td></td><td>58</td><td>57</td><td>56</td><td>55</td><td>54</td><td>53</td></tr> <tr><td>52</td><td>51</td><td>50</td><td>49</td><td></td><td></td><td></td><td></td><td>44</td><td>43</td><td>42</td><td>41</td><td>40</td><td></td><td></td><td>37</td><td>36</td><td></td><td></td><td>34</td></tr> <tr><td></td><td></td><td></td><td></td><td></td><td></td><td></td><td>32</td><td></td><td>29</td><td>28</td><td>27</td><td>26</td><td></td><td></td><td></td><td></td><td></td><td>19</td><td>18</td></tr> <tr><td></td><td>73</td><td></td><td></td><td></td><td>16</td><td>15</td><td>14</td><td>13</td><td>12</td><td>11</td><td>10</td><td></td><td></td><td></td><td></td><td></td><td>3</td><td></td><td></td></tr> </table>			70	69						63	62	61	60		58	57	56	55	54	53	52	51	50	49					44	43	42	41	40			37	36			34								32		29	28	27	26						19	18		73				16	15	14	13	12	11	10						3												
		70	69						63	62	61	60		58	57	56	55	54	53																																																																														
52	51	50	49					44	43	42	41	40			37	36			34																																																																														
							32		29	28	27	26						19	18																																																																														
	73				16	15	14	13	12	11	10						3																																																																																
AVAILABLE	NOT APPLICABLE	34566-4443	G	9	A	BLACK	<table border="1"> <tr><td></td><td></td><td></td><td></td><td></td><td>67</td><td>66</td><td></td><td></td><td></td><td></td><td></td><td></td><td></td><td></td><td></td><td></td><td></td><td></td><td></td></tr> <tr><td></td><td></td><td></td><td></td><td></td><td>48</td><td>47</td><td></td><td></td><td></td><td>41</td><td></td><td></td><td></td><td></td><td></td><td></td><td></td><td></td><td></td></tr> <tr><td></td><td></td><td></td><td></td><td></td><td>32</td><td>31</td><td>30</td><td>29</td><td></td><td>27</td><td>26</td><td>25</td><td></td><td></td><td>22</td><td>21</td><td></td><td>19</td><td>18</td><td>17</td></tr> <tr><td></td><td></td><td></td><td></td><td></td><td>16</td><td>15</td><td>14</td><td>13</td><td></td><td>11</td><td>10</td><td>9</td><td>8</td><td>7</td><td>6</td><td>5</td><td>4</td><td>3</td><td></td><td>1</td></tr> </table>						67	66																			48	47				41															32	31	30	29		27	26	25			22	21		19	18	17						16	15	14	13		11	10	9	8	7	6	5	4	3		1								
					67	66																																																																																											
					48	47				41																																																																																							
					32	31	30	29		27	26	25			22	21		19	18	17																																																																													
					16	15	14	13		11	10	9	8	7	6	5	4	3		1																																																																													
AVAILABLE	NOT APPLICABLE	34566-4453	G	0	A	BLACK	<table border="1"> <tr><td>72</td><td>71</td><td>70</td><td>69</td><td>68</td><td></td><td></td><td></td><td>65</td><td>64</td><td>63</td><td>62</td><td>61</td><td>60</td><td>59</td><td>58</td><td>57</td><td>56</td><td>55</td><td>54</td><td>53</td></tr> <tr><td>52</td><td>51</td><td>50</td><td>49</td><td>48</td><td></td><td></td><td></td><td>46</td><td>45</td><td>44</td><td>43</td><td>42</td><td>40</td><td>39</td><td>38</td><td>37</td><td>36</td><td>35</td><td>34</td><td>33</td></tr> <tr><td></td><td></td><td></td><td></td><td></td><td></td><td></td><td></td><td></td><td></td><td>28</td><td></td><td></td><td></td><td>24</td><td>23</td><td></td><td>20</td><td></td><td></td><td></td></tr> <tr><td></td><td></td><td></td><td></td><td></td><td></td><td></td><td></td><td></td><td></td><td>12</td><td>11</td><td></td><td></td><td></td><td></td><td></td><td></td><td></td><td>2</td><td>1</td></tr> </table>	72	71	70	69	68				65	64	63	62	61	60	59	58	57	56	55	54	53	52	51	50	49	48				46	45	44	43	42	40	39	38	37	36	35	34	33											28				24	23		20														12	11								2	1						
72	71	70	69	68				65	64	63	62	61	60	59	58	57	56	55	54	53																																																																													
52	51	50	49	48				46	45	44	43	42	40	39	38	37	36	35	34	33																																																																													
										28				24	23		20																																																																																
										12	11								2	1																																																																													
AVAILABLE	NOT APPLICABLE	34566-4463	G	9	B	ST GRY	<table border="1"> <tr><td></td><td></td><td></td><td></td><td></td><td></td><td></td><td></td><td></td><td>63</td><td></td><td></td><td></td><td></td><td></td><td></td><td></td><td></td><td></td><td>53</td></tr> <tr><td></td><td></td><td></td><td></td><td></td><td></td><td></td><td></td><td></td><td>48</td><td>47</td><td></td><td>45</td><td>43</td><td>42</td><td></td><td>39</td><td></td><td></td><td>35</td><td>34</td><td>33</td></tr> <tr><td></td><td></td><td></td><td></td><td></td><td></td><td></td><td></td><td></td><td></td><td></td><td></td><td></td><td></td><td>26</td><td></td><td>23</td><td>22</td><td></td><td></td><td>19</td><td></td></tr> <tr><td></td><td></td><td></td><td></td><td></td><td></td><td></td><td></td><td></td><td></td><td></td><td></td><td></td><td></td><td></td><td></td><td></td><td></td><td></td><td></td><td></td><td>1</td></tr> </table>										63										53										48	47		45	43	42		39			35	34	33															26		23	22			19																							1				
									63										53																																																																														
									48	47		45	43	42		39			35	34	33																																																																												
														26		23	22			19																																																																													
																					1																																																																												
AVAILABLE	NOT APPLICABLE	34566-4473	G	0	B	ST GRY	<table border="1"> <tr><td></td><td></td><td></td><td></td><td></td><td></td><td></td><td></td><td></td><td>64</td><td>63</td><td>62</td><td></td><td></td><td>59</td><td>58</td><td></td><td></td><td></td><td></td><td>53</td></tr> <tr><td></td><td></td><td></td><td></td><td></td><td></td><td></td><td></td><td></td><td>47</td><td>45</td><td></td><td>43</td><td>42</td><td></td><td>39</td><td></td><td></td><td></td><td></td><td>35</td><td>34</td><td>33</td></tr> <tr><td></td><td></td><td></td><td></td><td></td><td></td><td></td><td></td><td></td><td></td><td></td><td></td><td></td><td>26</td><td>25</td><td></td><td>23</td><td>22</td><td></td><td></td><td></td><td></td><td></td></tr> <tr><td></td><td></td><td></td><td></td><td></td><td></td><td></td><td></td><td></td><td></td><td></td><td></td><td></td><td></td><td></td><td></td><td></td><td></td><td></td><td></td><td>3</td><td></td><td>1</td></tr> </table>										64	63	62			59	58					53										47	45		43	42		39					35	34	33														26	25		23	22																										3		1
									64	63	62			59	58					53																																																																													
									47	45		43	42		39					35	34	33																																																																											
													26	25		23	22																																																																																
																				3		1																																																																											

ENTER DESCRIPTION EC NO: UAU2013-0662 DRAWN BY: [] CHKD: [] APPR: IKOSHY 2012/11/21	QUALITY SYMBOLS	GENERAL TOLERANCES (UNLESS SPECIFIED)	DIMENSION STYLE	SCALE	DESIGN UNITS	THIRD ANGLE PROJECTION
	▽=0	mm INCH	MM ONLY		METRIC	
	▽=0	4 PLACES	DRAWN BY: SKRA JENDRANA	DATE: 2011/02/14	TITLE: MX123	
	▽=0	3 PLACES	CHECKED BY: MYANSLAMBROU	DATE: 2011/02/14	HRNS CONN ASSY	
	ANGULAR ±	DRAFT WHERE APPLICABLE	MATERIAL NO.	DOCUMENT NO.		SHEET NO.
	MUST REMAIN WITHIN DIMENSIONS	SEE BOM TABLE	SD-34566-001			51 OF 59
			THIS DRAWING CONTAINS INFORMATION THAT IS PROPRIETARY TO MOLEX INCORPORATED AND SHOULD NOT BE USED WITHOUT WRITTEN PERMISSION			

STATUS	GM PART #	MATERIAL #	PART/MATERIAL REVISION	WIRE DRESS OPTION	KEY OPTION	COLOR (TPA)	NUMBERS INDICATE CAVITIES OPEN FOR CIRCUITS																																																																																		
AVAILABLE	NOT APPLICABLE	34566-4683	G	9	B	ST GRAY	<table border="1"> <tr><td>72</td><td>71</td><td>70</td><td>69</td><td>68</td><td>67</td><td>66</td><td>65</td><td>64</td><td></td><td>62</td><td>61</td><td>60</td><td>59</td><td>58</td><td>57</td><td>56</td><td>55</td><td>54</td></tr> <tr><td>52</td><td>51</td><td>50</td><td>49</td><td></td><td></td><td>46</td><td>44</td><td></td><td></td><td>41</td><td>40</td><td></td><td>38</td><td>37</td><td>36</td><td></td><td></td><td></td></tr> <tr><td></td><td></td><td></td><td></td><td>73</td><td></td><td>32</td><td>31</td><td>30</td><td>29</td><td>28</td><td>27</td><td>25</td><td>24</td><td></td><td>21</td><td>20</td><td></td><td>18</td><td>17</td></tr> <tr><td></td><td></td><td></td><td></td><td></td><td></td><td>16</td><td>15</td><td>14</td><td>13</td><td>12</td><td></td><td>10</td><td>9</td><td>8</td><td>7</td><td>6</td><td>5</td><td>4</td><td>3</td><td>2</td></tr> </table>	72	71	70	69	68	67	66	65	64		62	61	60	59	58	57	56	55	54	52	51	50	49			46	44			41	40		38	37	36								73		32	31	30	29	28	27	25	24		21	20		18	17							16	15	14	13	12		10	9	8	7	6	5	4	3	2			
72	71	70	69	68	67	66	65	64		62	61	60	59	58	57	56	55	54																																																																							
52	51	50	49			46	44			41	40		38	37	36																																																																										
				73		32	31	30	29	28	27	25	24		21	20		18	17																																																																						
						16	15	14	13	12		10	9	8	7	6	5	4	3	2																																																																					
AVAILABLE	NOT APPLICABLE	34566-4693	G	0	B	ST GRAY	<table border="1"> <tr><td>72</td><td>71</td><td>70</td><td>69</td><td>68</td><td>67</td><td>66</td><td>65</td><td></td><td></td><td>61</td><td>60</td><td></td><td></td><td>57</td><td>56</td><td>55</td><td>54</td><td></td><td></td></tr> <tr><td>52</td><td>51</td><td>50</td><td>49</td><td>48</td><td></td><td>46</td><td>44</td><td></td><td></td><td>41</td><td>40</td><td></td><td>38</td><td>37</td><td>36</td><td></td><td></td><td></td><td></td></tr> <tr><td></td><td></td><td></td><td></td><td>73</td><td></td><td>32</td><td>31</td><td>30</td><td>29</td><td>28</td><td>27</td><td></td><td>24</td><td></td><td>21</td><td>20</td><td>19</td><td>18</td><td>17</td></tr> <tr><td></td><td></td><td></td><td></td><td></td><td></td><td>16</td><td>15</td><td>14</td><td>13</td><td>12</td><td>11</td><td>10</td><td>9</td><td>8</td><td>7</td><td>6</td><td>5</td><td>4</td><td>3</td><td>2</td></tr> </table>	72	71	70	69	68	67	66	65			61	60			57	56	55	54			52	51	50	49	48		46	44			41	40		38	37	36									73		32	31	30	29	28	27		24		21	20	19	18	17							16	15	14	13	12	11	10	9	8	7	6	5	4	3	2	
72	71	70	69	68	67	66	65			61	60			57	56	55	54																																																																								
52	51	50	49	48		46	44			41	40		38	37	36																																																																										
				73		32	31	30	29	28	27		24		21	20	19	18	17																																																																						
						16	15	14	13	12	11	10	9	8	7	6	5	4	3	2																																																																					
AVAILABLE	NOT APPLICABLE	34566-47B	G	0	A	BLACK	<table border="1"> <tr><td>72</td><td>71</td><td>70</td><td>69</td><td></td><td>67</td><td></td><td></td><td>64</td><td>63</td><td></td><td></td><td>60</td><td>59</td><td></td><td></td><td>56</td><td>55</td><td>54</td><td>53</td></tr> <tr><td>52</td><td>51</td><td></td><td>49</td><td></td><td>47</td><td></td><td>45</td><td>44</td><td>43</td><td>42</td><td>41</td><td></td><td></td><td></td><td></td><td>36</td><td></td><td></td><td></td></tr> <tr><td></td><td></td><td></td><td></td><td>73</td><td></td><td>32</td><td></td><td>30</td><td></td><td>28</td><td>26</td><td></td><td></td><td>23</td><td></td><td></td><td></td><td>19</td><td>18</td></tr> <tr><td></td><td></td><td></td><td></td><td></td><td></td><td>16</td><td>15</td><td></td><td></td><td>12</td><td>10</td><td></td><td></td><td></td><td></td><td></td><td></td><td>3</td><td></td></tr> </table>	72	71	70	69		67			64	63			60	59			56	55	54	53	52	51		49		47		45	44	43	42	41					36								73		32		30		28	26			23				19	18							16	15			12	10							3			
72	71	70	69		67			64	63			60	59			56	55	54	53																																																																						
52	51		49		47		45	44	43	42	41					36																																																																									
				73		32		30		28	26			23				19	18																																																																						
						16	15			12	10							3																																																																							
AVAILABLE	NOT APPLICABLE	34566-4723	G	0	A	BLACK	<table border="1"> <tr><td>72</td><td>71</td><td>70</td><td>69</td><td></td><td></td><td></td><td></td><td>64</td><td>63</td><td></td><td></td><td>60</td><td>59</td><td>58</td><td></td><td>56</td><td>55</td><td>54</td><td>53</td></tr> <tr><td>52</td><td>51</td><td></td><td>49</td><td></td><td>47</td><td></td><td>45</td><td>44</td><td>43</td><td>42</td><td>41</td><td></td><td></td><td></td><td></td><td>36</td><td></td><td></td><td></td></tr> <tr><td></td><td></td><td></td><td></td><td>73</td><td></td><td>32</td><td></td><td>30</td><td></td><td>28</td><td>26</td><td></td><td></td><td></td><td></td><td></td><td></td><td>19</td><td>18</td></tr> <tr><td></td><td></td><td></td><td></td><td></td><td></td><td>16</td><td>15</td><td></td><td></td><td>12</td><td>10</td><td></td><td></td><td></td><td></td><td></td><td></td><td>3</td><td></td></tr> </table>	72	71	70	69					64	63			60	59	58		56	55	54	53	52	51		49		47		45	44	43	42	41					36								73		32		30		28	26							19	18							16	15			12	10							3			
72	71	70	69					64	63			60	59	58		56	55	54	53																																																																						
52	51		49		47		45	44	43	42	41					36																																																																									
				73		32		30		28	26							19	18																																																																						
						16	15			12	10							3																																																																							
AVAILABLE	NOT APPLICABLE	34566-4733	G	0	A	BLACK	<table border="1"> <tr><td>72</td><td>71</td><td>70</td><td>69</td><td></td><td></td><td></td><td></td><td>64</td><td>63</td><td></td><td></td><td>60</td><td>59</td><td>58</td><td></td><td>56</td><td>55</td><td>54</td><td>53</td></tr> <tr><td>52</td><td>51</td><td></td><td>49</td><td></td><td>47</td><td></td><td>45</td><td>44</td><td>43</td><td>42</td><td>41</td><td></td><td></td><td></td><td></td><td>36</td><td></td><td></td><td></td></tr> <tr><td></td><td></td><td></td><td></td><td>73</td><td></td><td>32</td><td></td><td>30</td><td></td><td>28</td><td>26</td><td></td><td></td><td></td><td></td><td>21</td><td>19</td><td>18</td><td></td></tr> <tr><td></td><td></td><td></td><td></td><td></td><td></td><td>16</td><td>15</td><td></td><td></td><td>12</td><td>10</td><td></td><td>8</td><td></td><td>5</td><td></td><td>3</td><td></td><td></td></tr> </table>	72	71	70	69					64	63			60	59	58		56	55	54	53	52	51		49		47		45	44	43	42	41					36								73		32		30		28	26					21	19	18								16	15			12	10		8		5		3				
72	71	70	69					64	63			60	59	58		56	55	54	53																																																																						
52	51		49		47		45	44	43	42	41					36																																																																									
				73		32		30		28	26					21	19	18																																																																							
						16	15			12	10		8		5		3																																																																								
AVAILABLE	NOT APPLICABLE	34566-4743	G	9	A	BLACK	<table border="1"> <tr><td>72</td><td>71</td><td>70</td><td>69</td><td></td><td>67</td><td></td><td>65</td><td>64</td><td>63</td><td>62</td><td>61</td><td>60</td><td>59</td><td>58</td><td>57</td><td>56</td><td>55</td><td>54</td><td>53</td></tr> <tr><td>52</td><td>51</td><td>50</td><td>49</td><td>48</td><td>47</td><td></td><td>45</td><td>44</td><td>43</td><td>42</td><td>41</td><td>40</td><td>39</td><td></td><td>37</td><td>36</td><td></td><td></td><td>34</td></tr> <tr><td></td><td></td><td></td><td></td><td>73</td><td></td><td>32</td><td></td><td>30</td><td>29</td><td>28</td><td>27</td><td>26</td><td></td><td>24</td><td>23</td><td></td><td>21</td><td>19</td><td>18</td><td>17</td></tr> <tr><td></td><td></td><td></td><td></td><td></td><td></td><td>16</td><td>15</td><td>14</td><td>13</td><td>12</td><td>11</td><td>10</td><td></td><td>8</td><td></td><td>5</td><td></td><td>3</td><td>2</td><td>1</td></tr> </table>	72	71	70	69		67		65	64	63	62	61	60	59	58	57	56	55	54	53	52	51	50	49	48	47		45	44	43	42	41	40	39		37	36			34					73		32		30	29	28	27	26		24	23		21	19	18	17							16	15	14	13	12	11	10		8		5		3	2	1
72	71	70	69		67		65	64	63	62	61	60	59	58	57	56	55	54	53																																																																						
52	51	50	49	48	47		45	44	43	42	41	40	39		37	36			34																																																																						
				73		32		30	29	28	27	26		24	23		21	19	18	17																																																																					
						16	15	14	13	12	11	10		8		5		3	2	1																																																																					
AVAILABLE	NOT APPLICABLE	34566-4753	G	0	B	ST.GRAY	<table border="1"> <tr><td></td><td></td><td></td><td></td><td>68</td><td>67</td><td></td><td></td><td>64</td><td></td><td></td><td></td><td></td><td></td><td></td><td></td><td>58</td><td></td><td></td><td></td></tr> <tr><td></td><td></td><td></td><td></td><td></td><td></td><td>46</td><td>45</td><td></td><td></td><td></td><td></td><td></td><td></td><td></td><td></td><td>38</td><td></td><td></td><td></td></tr> <tr><td></td><td></td><td></td><td></td><td>73</td><td></td><td>32</td><td></td><td>30</td><td>29</td><td>28</td><td>27</td><td></td><td></td><td></td><td>22</td><td></td><td></td><td></td><td>17</td></tr> <tr><td></td><td></td><td></td><td></td><td></td><td></td><td>15</td><td></td><td>13</td><td></td><td></td><td>10</td><td></td><td></td><td>6</td><td></td><td></td><td></td><td></td><td>1</td></tr> </table>					68	67			64								58										46	45									38								73		32		30	29	28	27				22				17							15		13			10			6					1		
				68	67			64								58																																																																									
						46	45									38																																																																									
				73		32		30	29	28	27				22				17																																																																						
						15		13			10			6					1																																																																						
AVAILABLE	NOT APPLICABLE	34566-4763	G	0	B	ST.GRAY	<table border="1"> <tr><td></td><td></td><td></td><td></td><td>68</td><td>67</td><td></td><td></td><td>64</td><td></td><td></td><td></td><td></td><td></td><td></td><td></td><td></td><td></td><td></td><td></td></tr> <tr><td></td><td></td><td></td><td></td><td></td><td></td><td>46</td><td>45</td><td></td><td></td><td></td><td></td><td></td><td></td><td></td><td></td><td></td><td></td><td></td><td></td></tr> <tr><td></td><td></td><td></td><td></td><td>73</td><td></td><td>32</td><td></td><td>30</td><td>29</td><td>28</td><td>27</td><td></td><td></td><td></td><td></td><td></td><td></td><td></td><td>17</td></tr> <tr><td></td><td></td><td></td><td></td><td></td><td></td><td>15</td><td></td><td>13</td><td></td><td></td><td>10</td><td></td><td></td><td>6</td><td></td><td></td><td></td><td></td><td></td></tr> </table>					68	67			64																		46	45																	73		32		30	29	28	27								17							15		13			10			6							
				68	67			64																																																																																	
						46	45																																																																																		
				73		32		30	29	28	27								17																																																																						
						15		13			10			6																																																																											
AVAILABLE	NOT APPLICABLE	34566-4773	G	0	B	ST.GRAY	<table border="1"> <tr><td></td><td></td><td></td><td></td><td>68</td><td>67</td><td></td><td></td><td>64</td><td></td><td></td><td></td><td></td><td></td><td>59</td><td>58</td><td></td><td></td><td></td><td>54</td></tr> <tr><td></td><td></td><td></td><td></td><td></td><td></td><td>46</td><td>45</td><td></td><td></td><td></td><td></td><td></td><td></td><td></td><td>39</td><td>38</td><td></td><td></td><td></td></tr> <tr><td></td><td></td><td></td><td></td><td>73</td><td></td><td>32</td><td></td><td>30</td><td>29</td><td>28</td><td>27</td><td></td><td></td><td>23</td><td>22</td><td></td><td></td><td></td><td>17</td></tr> <tr><td></td><td></td><td></td><td></td><td></td><td></td><td>15</td><td></td><td>13</td><td></td><td></td><td>10</td><td></td><td>8</td><td>6</td><td></td><td></td><td></td><td></td><td>1</td></tr> </table>					68	67			64						59	58				54							46	45								39	38								73		32		30	29	28	27			23	22				17							15		13			10		8	6					1		
				68	67			64						59	58				54																																																																						
						46	45								39	38																																																																									
				73		32		30	29	28	27			23	22				17																																																																						
						15		13			10		8	6					1																																																																						

ENTER DESCRIPTION EC NO: UAU2013-0662 DRAWN BY: 2012/11/01 CHKD: 2012/11/21 APPR: VIOSHY REV:	QUALITY SYMBOLS	GENERAL TOLERANCES (UNLESS SPECIFIED)	DIMENSION STYLE	SCALE	DESIGN UNITS	THIRD ANGLE PROJECTION
	∇=0 ∇=0 ∇=0	mm INCH 4 PLACES ± --- ± --- 3 PLACES ± --- ± --- 2 PLACES ± --- ± --- 1 PLACE ± --- ± --- 0 PLACE ± --- ± ---	MM ONLY	1:1	METRIC	SKRA JENDRANA 2011/02/14 MYANSLAMBROU 2011/02/14
	ANGULAR ± ---° DRAFT WHERE APPLICABLE MUST REMAIN WITHIN DIMENSIONS	DRAWN BY: SKRA JENDRANA 2011/02/14 CHECKED BY: MYANSLAMBROU 2011/02/14 APPROVED BY:	MATERIAL NO. SEE BOM TABLE DOCUMENT NO. SD-34566-001	TITLE: MX123 66/73/80CKT HRNS CONN ASSY molex	SHEET NO. 54 OF 59	
	THIS DRAWING CONTAINS INFORMATION THAT IS PROPRIETARY TO MOLEX INCORPORATED AND SHOULD NOT BE USED WITHOUT WRITTEN PERMISSION					

STATUS	GM PART #	MATERIAL #	PART/MATERIAL REVISION	WIRE DRESS OPTION	KEY OPTION	COLOR (TPA)	NUMBERS INDICATE CAVITIES OPEN FOR CIRCUITS																																																																															
AVAILABLE	NOT APPLICABLE	34566-4783	G	0	B	ST.GRY	<table border="1"> <tr><td></td><td></td><td></td><td>68</td><td>67</td><td></td><td></td><td>64</td><td>63</td><td></td><td></td><td></td><td></td><td>58</td><td></td><td>55</td><td></td><td></td></tr> <tr><td></td><td></td><td></td><td></td><td></td><td>46</td><td>45</td><td></td><td>43</td><td></td><td></td><td></td><td></td><td>38</td><td></td><td>35</td><td></td><td></td></tr> <tr><td>73</td><td></td><td></td><td>32</td><td>31</td><td>30</td><td>29</td><td>28</td><td>27</td><td></td><td></td><td></td><td></td><td>22</td><td></td><td>19</td><td></td><td>17</td></tr> <tr><td></td><td></td><td></td><td></td><td>15</td><td></td><td>13</td><td></td><td></td><td>10</td><td></td><td></td><td></td><td>6</td><td></td><td></td><td></td><td>1</td></tr> </table>				68	67			64	63					58		55								46	45		43					38		35			73			32	31	30	29	28	27					22		19		17					15		13			10				6				1							
			68	67			64	63					58		55																																																																							
					46	45		43					38		35																																																																							
73			32	31	30	29	28	27					22		19		17																																																																					
				15		13			10				6				1																																																																					
AVAILABLE	NOT APPLICABLE	34566-4793	G	0	B	ST.GRY	<table border="1"> <tr><td></td><td></td><td></td><td>68</td><td>67</td><td></td><td></td><td>64</td><td>63</td><td></td><td></td><td></td><td></td><td>58</td><td></td><td></td><td></td><td></td></tr> <tr><td></td><td></td><td></td><td></td><td></td><td>46</td><td>45</td><td></td><td>43</td><td></td><td></td><td></td><td></td><td>38</td><td></td><td></td><td></td><td></td></tr> <tr><td>73</td><td></td><td></td><td>32</td><td>31</td><td>30</td><td>29</td><td>28</td><td>27</td><td></td><td></td><td></td><td></td><td>22</td><td></td><td>19</td><td></td><td>17</td></tr> <tr><td></td><td></td><td></td><td></td><td>15</td><td></td><td>13</td><td></td><td></td><td>10</td><td></td><td></td><td></td><td>6</td><td></td><td></td><td></td><td></td></tr> </table>				68	67			64	63					58										46	45		43					38					73			32	31	30	29	28	27					22		19		17					15		13			10				6											
			68	67			64	63					58																																																																									
					46	45		43					38																																																																									
73			32	31	30	29	28	27					22		19		17																																																																					
				15		13			10				6																																																																									
AVAILABLE	NOT APPLICABLE	34566-4813	G	9	B	ST.GRY	<table border="1"> <tr><td></td><td></td><td></td><td>68</td><td>67</td><td></td><td></td><td>64</td><td></td><td></td><td></td><td></td><td></td><td>59</td><td>58</td><td></td><td></td><td>54</td></tr> <tr><td></td><td></td><td></td><td></td><td></td><td>46</td><td>45</td><td></td><td></td><td></td><td></td><td></td><td></td><td>39</td><td>38</td><td></td><td></td><td></td></tr> <tr><td>73</td><td></td><td></td><td>32</td><td>31</td><td>30</td><td>29</td><td>28</td><td>27</td><td></td><td></td><td></td><td></td><td>23</td><td>22</td><td></td><td></td><td>17</td></tr> <tr><td></td><td></td><td></td><td></td><td>15</td><td></td><td>13</td><td></td><td></td><td>10</td><td>9</td><td>8</td><td></td><td>6</td><td></td><td></td><td></td><td>1</td></tr> </table>				68	67			64						59	58			54						46	45							39	38				73			32	31	30	29	28	27					23	22			17					15		13			10	9	8		6				1							
			68	67			64						59	58			54																																																																					
					46	45							39	38																																																																								
73			32	31	30	29	28	27					23	22			17																																																																					
				15		13			10	9	8		6				1																																																																					
AVAILABLE	NOT APPLICABLE	34566-4823	G	0	C	BLUE	<table border="1"> <tr><td></td><td></td><td></td><td>68</td><td>67</td><td>66</td><td>65</td><td>64</td><td></td><td></td><td></td><td></td><td></td><td>59</td><td>58</td><td>57</td><td>55</td><td>54</td><td>53</td></tr> <tr><td>51</td><td>50</td><td>49</td><td>48</td><td>47</td><td>46</td><td>45</td><td></td><td>43</td><td>42</td><td>41</td><td>40</td><td>39</td><td>38</td><td>37</td><td></td><td>35</td><td></td><td>33</td></tr> <tr><td>73</td><td></td><td></td><td>32</td><td>31</td><td>30</td><td></td><td></td><td>26</td><td>25</td><td>24</td><td>23</td><td>22</td><td></td><td>20</td><td></td><td></td><td></td><td></td></tr> <tr><td></td><td></td><td></td><td></td><td>16</td><td></td><td></td><td>13</td><td></td><td>10</td><td>9</td><td>8</td><td>7</td><td>6</td><td>5</td><td>4</td><td>3</td><td>2</td><td></td></tr> </table>				68	67	66	65	64						59	58	57	55	54	53	51	50	49	48	47	46	45		43	42	41	40	39	38	37		35		33	73			32	31	30			26	25	24	23	22		20									16			13		10	9	8	7	6	5	4	3	2				
			68	67	66	65	64						59	58	57	55	54	53																																																																				
51	50	49	48	47	46	45		43	42	41	40	39	38	37		35		33																																																																				
73			32	31	30			26	25	24	23	22		20																																																																								
				16			13		10	9	8	7	6	5	4	3	2																																																																					
AVAILABLE	NOT APPLICABLE	34566-4833	G	0	C	BLUE	<table border="1"> <tr><td>72</td><td>70</td><td></td><td>68</td><td>67</td><td>66</td><td></td><td></td><td>63</td><td>62</td><td></td><td></td><td></td><td>59</td><td>57</td><td></td><td></td><td></td><td>53</td></tr> <tr><td>52</td><td>51</td><td></td><td>48</td><td>47</td><td>46</td><td>44</td><td></td><td>42</td><td></td><td>40</td><td>39</td><td></td><td>37</td><td>36</td><td></td><td></td><td></td><td>34</td><td>33</td></tr> <tr><td>73</td><td></td><td></td><td>32</td><td>31</td><td>30</td><td></td><td></td><td>27</td><td>26</td><td>25</td><td>24</td><td></td><td>22</td><td>21</td><td></td><td></td><td></td><td></td><td></td></tr> <tr><td></td><td></td><td></td><td></td><td>15</td><td>14</td><td></td><td></td><td></td><td>10</td><td>9</td><td>8</td><td></td><td>6</td><td>5</td><td>4</td><td></td><td></td><td></td><td>2</td></tr> </table>	72	70		68	67	66			63	62				59	57				53	52	51		48	47	46	44		42		40	39		37	36				34	33	73			32	31	30			27	26	25	24		22	21										15	14				10	9	8		6	5	4				2
72	70		68	67	66			63	62				59	57				53																																																																				
52	51		48	47	46	44		42		40	39		37	36				34	33																																																																			
73			32	31	30			27	26	25	24		22	21																																																																								
				15	14				10	9	8		6	5	4				2																																																																			
AVAILABLE	NOT APPLICABLE	34566-4843	G	0	C	BLUE	<table border="1"> <tr><td>72</td><td>70</td><td></td><td>68</td><td>67</td><td>66</td><td></td><td></td><td>63</td><td>62</td><td></td><td></td><td></td><td>59</td><td>57</td><td></td><td></td><td></td><td>53</td></tr> <tr><td>52</td><td>51</td><td></td><td>48</td><td>47</td><td>46</td><td>44</td><td></td><td>42</td><td></td><td>40</td><td>39</td><td></td><td>37</td><td>36</td><td></td><td></td><td></td><td>34</td><td>33</td></tr> <tr><td>73</td><td></td><td></td><td>32</td><td>31</td><td>30</td><td></td><td></td><td>27</td><td>26</td><td>25</td><td>24</td><td></td><td>22</td><td>21</td><td></td><td></td><td></td><td></td><td></td></tr> <tr><td></td><td></td><td></td><td></td><td>15</td><td>14</td><td></td><td></td><td></td><td>10</td><td>9</td><td>8</td><td></td><td>6</td><td>5</td><td>4</td><td></td><td></td><td></td><td>2</td></tr> </table>	72	70		68	67	66			63	62				59	57				53	52	51		48	47	46	44		42		40	39		37	36				34	33	73			32	31	30			27	26	25	24		22	21										15	14				10	9	8		6	5	4				2
72	70		68	67	66			63	62				59	57				53																																																																				
52	51		48	47	46	44		42		40	39		37	36				34	33																																																																			
73			32	31	30			27	26	25	24		22	21																																																																								
				15	14				10	9	8		6	5	4				2																																																																			
AVAILABLE	NOT APPLICABLE	34566-4853	G	0	C	BLUE	<table border="1"> <tr><td>72</td><td>70</td><td></td><td>68</td><td></td><td>66</td><td></td><td></td><td>63</td><td>62</td><td></td><td></td><td></td><td>59</td><td>57</td><td>56</td><td>55</td><td></td><td>53</td></tr> <tr><td>52</td><td>51</td><td></td><td>48</td><td>47</td><td>46</td><td>44</td><td></td><td>42</td><td></td><td>40</td><td>39</td><td></td><td>37</td><td>36</td><td></td><td></td><td></td><td>34</td><td>33</td></tr> <tr><td>73</td><td></td><td></td><td>32</td><td>31</td><td>30</td><td></td><td></td><td>27</td><td>26</td><td>25</td><td>24</td><td></td><td>22</td><td>21</td><td></td><td></td><td></td><td>19</td><td>18</td></tr> <tr><td></td><td></td><td></td><td></td><td>15</td><td>14</td><td></td><td></td><td></td><td>10</td><td>9</td><td>8</td><td></td><td>6</td><td>5</td><td>4</td><td>3</td><td>2</td><td></td><td></td></tr> </table>	72	70		68		66			63	62				59	57	56	55		53	52	51		48	47	46	44		42		40	39		37	36				34	33	73			32	31	30			27	26	25	24		22	21				19	18					15	14				10	9	8		6	5	4	3	2		
72	70		68		66			63	62				59	57	56	55		53																																																																				
52	51		48	47	46	44		42		40	39		37	36				34	33																																																																			
73			32	31	30			27	26	25	24		22	21				19	18																																																																			
				15	14				10	9	8		6	5	4	3	2																																																																					
AVAILABLE	NOT APPLICABLE	34566-4863	G	0	C	BLUE	<table border="1"> <tr><td>72</td><td>70</td><td></td><td>68</td><td></td><td>66</td><td></td><td></td><td>63</td><td>62</td><td></td><td></td><td></td><td>59</td><td>57</td><td></td><td></td><td></td><td>53</td></tr> <tr><td>52</td><td>51</td><td></td><td>48</td><td>47</td><td>46</td><td>44</td><td></td><td>42</td><td></td><td>40</td><td>39</td><td></td><td>37</td><td>36</td><td></td><td></td><td></td><td>34</td><td>33</td></tr> <tr><td>73</td><td></td><td></td><td>32</td><td>31</td><td>30</td><td></td><td></td><td>27</td><td>26</td><td>25</td><td>24</td><td></td><td>22</td><td>21</td><td></td><td></td><td></td><td></td><td></td></tr> <tr><td></td><td></td><td></td><td></td><td>15</td><td>14</td><td></td><td></td><td></td><td>10</td><td>9</td><td>8</td><td></td><td>6</td><td>5</td><td>4</td><td></td><td></td><td></td><td>2</td></tr> </table>	72	70		68		66			63	62				59	57				53	52	51		48	47	46	44		42		40	39		37	36				34	33	73			32	31	30			27	26	25	24		22	21										15	14				10	9	8		6	5	4				2
72	70		68		66			63	62				59	57				53																																																																				
52	51		48	47	46	44		42		40	39		37	36				34	33																																																																			
73			32	31	30			27	26	25	24		22	21																																																																								
				15	14				10	9	8		6	5	4				2																																																																			
AVAILABLE	NOT APPLICABLE	34566-4873	G	0	C	BLUE	<table border="1"> <tr><td>72</td><td>70</td><td></td><td>68</td><td></td><td>66</td><td></td><td></td><td>63</td><td>62</td><td></td><td></td><td></td><td>59</td><td>57</td><td></td><td></td><td></td><td>53</td></tr> <tr><td>52</td><td>51</td><td></td><td>48</td><td>47</td><td>46</td><td>44</td><td></td><td>42</td><td></td><td>40</td><td>39</td><td></td><td>37</td><td>36</td><td></td><td></td><td></td><td>34</td><td>33</td></tr> <tr><td>73</td><td></td><td></td><td>32</td><td>31</td><td>30</td><td></td><td></td><td>27</td><td>26</td><td>25</td><td>24</td><td></td><td>22</td><td>21</td><td></td><td></td><td></td><td></td><td></td></tr> <tr><td></td><td></td><td></td><td></td><td>15</td><td>14</td><td></td><td></td><td></td><td>10</td><td>9</td><td>8</td><td></td><td>6</td><td>5</td><td>4</td><td></td><td></td><td></td><td>2</td></tr> </table>	72	70		68		66			63	62				59	57				53	52	51		48	47	46	44		42		40	39		37	36				34	33	73			32	31	30			27	26	25	24		22	21										15	14				10	9	8		6	5	4				2
72	70		68		66			63	62				59	57				53																																																																				
52	51		48	47	46	44		42		40	39		37	36				34	33																																																																			
73			32	31	30			27	26	25	24		22	21																																																																								
				15	14				10	9	8		6	5	4				2																																																																			

ENTER DESCRIPTION EC NO: UAU2013-0662 DRAWN BY: 2012/11/01 CHKD: APPR: WJSHY 2012/11/21 REV:	QUALITY SYMBOLS	GENERAL TOLERANCES (UNLESS SPECIFIED)	DIMENSION STYLE	SCALE	DESIGN UNITS	THIRD ANGLE PROJECTION	
	∇=0 ∇=0 ∇=0	4 PLACES ±---+--- 3 PLACES ±---+--- 2 PLACES ±---+--- 1 PLACE ±---+--- 0 PLACE ±---+---	mm INCH ± ± ± ± ± ± ± ± ± ±	MM ONLY	1:1	METRIC	SKRAJENDRANA 2011/02/14 MVANSLAMBROU 2011/02/14
	ANGULAR ±---° DRAFT WHERE APPLICABLE MUST REMAIN WITHIN DIMENSIONS	SEE BOM TABLE THIS DRAWING CONTAINS INFORMATION THAT IS PROPRIETARY TO MOLEX INCORPORATED AND SHOULD NOT BE USED WITHOUT WRITTEN PERMISSION	MATERIAL NO. DOCUMENT NO.	TITLE MX123 66/73/80CKT HRNS CONN ASSY molex SD-34566-001	SHEET NO. 55 OF 59		
	INCORPORATED AND SHOULD NOT BE USED WITHOUT WRITTEN PERMISSION						

STATUS	GM PART #	MATERIAL #	PART/MATERIAL REVISION	WIRE DRESS OPTION	KEY OPTION	COLOR (TFA)	NUMBERS INDICATE CAVITIES OPEN FOR CIRCUITS																																																																									
AVAILABLE	NOT APPLICABLE	34566-4883	G	9	A	BLACK	<table border="1"> <tr><td>72</td><td></td><td>69</td><td>67</td><td>65</td><td>63</td><td></td><td>60</td><td></td><td>57</td><td>56</td><td></td><td>53</td></tr> <tr><td></td><td></td><td>49</td><td>47</td><td>46</td><td>44</td><td>43</td><td>40</td><td></td><td>37</td><td>36</td><td>35</td><td>33</td></tr> <tr><td>73</td><td></td><td></td><td>31</td><td>30</td><td>29</td><td>28</td><td></td><td>24</td><td></td><td>21</td><td>20</td><td>17</td></tr> <tr><td></td><td></td><td></td><td>16</td><td>15</td><td>14</td><td>13</td><td></td><td></td><td></td><td>5</td><td>4</td><td>3</td><td>2</td><td>1</td></tr> </table>	72		69	67	65	63		60		57	56		53			49	47	46	44	43	40		37	36	35	33	73			31	30	29	28		24		21	20	17				16	15	14	13				5	4	3	2	1																			
72		69	67	65	63		60		57	56		53																																																																				
		49	47	46	44	43	40		37	36	35	33																																																																				
73			31	30	29	28		24		21	20	17																																																																				
			16	15	14	13				5	4	3	2	1																																																																		
AVAILABLE	NOT APPLICABLE	34566-4893	G	9	B	ST.GRAY	<table border="1"> <tr><td></td><td></td><td>68</td><td>67</td><td></td><td>64</td><td>63</td><td></td><td></td><td>58</td><td></td><td>55</td><td></td></tr> <tr><td></td><td></td><td></td><td>46</td><td>45</td><td>43</td><td></td><td></td><td></td><td>38</td><td></td><td>35</td><td></td></tr> <tr><td>73</td><td></td><td>32</td><td>30</td><td>29</td><td>28</td><td>27</td><td></td><td></td><td>22</td><td></td><td>19</td><td>17</td></tr> <tr><td></td><td></td><td></td><td>15</td><td>13</td><td></td><td></td><td>10</td><td></td><td></td><td></td><td></td><td></td><td></td><td>1</td></tr> </table>			68	67		64	63			58		55					46	45	43				38		35		73		32	30	29	28	27			22		19	17				15	13			10							1																			
		68	67		64	63			58		55																																																																					
			46	45	43				38		35																																																																					
73		32	30	29	28	27			22		19	17																																																																				
			15	13			10							1																																																																		
AVAILABLE	NOT APPLICABLE	34566-4913	G	9	B	ST.GRAY	<table border="1"> <tr><td></td><td></td><td>68</td><td>67</td><td></td><td>64</td><td>63</td><td></td><td></td><td>58</td><td>57</td><td>55</td><td>53</td></tr> <tr><td></td><td></td><td></td><td>46</td><td>45</td><td>43</td><td></td><td></td><td></td><td>38</td><td>37</td><td>35</td><td></td></tr> <tr><td>73</td><td></td><td>32</td><td>30</td><td>29</td><td>28</td><td>27</td><td></td><td></td><td>22</td><td>21</td><td>19</td><td>17</td></tr> <tr><td></td><td></td><td></td><td></td><td></td><td>12</td><td>10</td><td></td><td></td><td></td><td></td><td></td><td></td><td></td><td>1</td></tr> </table>			68	67		64	63			58	57	55	53				46	45	43				38	37	35		73		32	30	29	28	27			22	21	19	17						12	10								1																			
		68	67		64	63			58	57	55	53																																																																				
			46	45	43				38	37	35																																																																					
73		32	30	29	28	27			22	21	19	17																																																																				
					12	10								1																																																																		
AVAILABLE	NOT APPLICABLE	34566-4923	G	9	A	BLACK	<table border="1"> <tr><td>72</td><td></td><td>69</td><td>67</td><td>65</td><td>63</td><td></td><td>60</td><td></td><td>57</td><td>56</td><td></td><td>53</td></tr> <tr><td></td><td></td><td>49</td><td>47</td><td></td><td>44</td><td>43</td><td>40</td><td></td><td>37</td><td>36</td><td>35</td><td>33</td></tr> <tr><td>73</td><td></td><td></td><td>31</td><td>30</td><td>29</td><td>28</td><td></td><td>24</td><td></td><td>21</td><td>20</td><td>17</td></tr> <tr><td></td><td></td><td></td><td>16</td><td>15</td><td>14</td><td>13</td><td></td><td></td><td></td><td>5</td><td>4</td><td>3</td><td>2</td><td>1</td></tr> </table>	72		69	67	65	63		60		57	56		53			49	47		44	43	40		37	36	35	33	73			31	30	29	28		24		21	20	17				16	15	14	13				5	4	3	2	1																			
72		69	67	65	63		60		57	56		53																																																																				
		49	47		44	43	40		37	36	35	33																																																																				
73			31	30	29	28		24		21	20	17																																																																				
			16	15	14	13				5	4	3	2	1																																																																		
AVAILABLE	NOT APPLICABLE	34566-4933	G	0	C	BLUE	<table border="1"> <tr><td>72</td><td>70</td><td>68</td><td>67</td><td></td><td>63</td><td>62</td><td></td><td>59</td><td>57</td><td></td><td></td><td>53</td></tr> <tr><td>52</td><td>51</td><td></td><td>48</td><td>47</td><td>46</td><td>44</td><td></td><td>40</td><td>39</td><td>37</td><td>36</td><td>35</td><td>34</td><td>33</td></tr> <tr><td>73</td><td></td><td>32</td><td>30</td><td></td><td>27</td><td>26</td><td>25</td><td>24</td><td>22</td><td>21</td><td></td><td></td><td></td><td></td></tr> <tr><td></td><td></td><td></td><td>15</td><td>14</td><td></td><td></td><td>10</td><td>9</td><td>8</td><td>6</td><td>5</td><td>4</td><td></td><td>2</td></tr> </table>	72	70	68	67		63	62		59	57			53	52	51		48	47	46	44		40	39	37	36	35	34	33	73		32	30		27	26	25	24	22	21								15	14			10	9	8	6	5	4		2															
72	70	68	67		63	62		59	57			53																																																																				
52	51		48	47	46	44		40	39	37	36	35	34	33																																																																		
73		32	30		27	26	25	24	22	21																																																																						
			15	14			10	9	8	6	5	4		2																																																																		
AVAILABLE	NOT APPLICABLE	34566-4943	G	0	A	BLACK	<table border="1"> <tr><td></td><td>70</td><td>69</td><td>68</td><td>67</td><td></td><td>63</td><td>62</td><td>61</td><td>60</td><td>59</td><td>58</td><td>57</td><td>56</td><td>55</td><td>54</td><td>53</td></tr> <tr><td>52</td><td>51</td><td>50</td><td>49</td><td></td><td></td><td>44</td><td>43</td><td>42</td><td>41</td><td>39</td><td>38</td><td>37</td><td>36</td><td></td><td>34</td><td></td></tr> <tr><td>73</td><td></td><td></td><td>32</td><td>31</td><td>29</td><td>28</td><td>27</td><td>26</td><td>25</td><td>23</td><td></td><td></td><td></td><td>19</td><td>18</td><td></td></tr> <tr><td></td><td></td><td></td><td>16</td><td>15</td><td>14</td><td>13</td><td>12</td><td>11</td><td>10</td><td>9</td><td>8</td><td></td><td></td><td></td><td>3</td><td></td></tr> </table>		70	69	68	67		63	62	61	60	59	58	57	56	55	54	53	52	51	50	49			44	43	42	41	39	38	37	36		34		73			32	31	29	28	27	26	25	23				19	18					16	15	14	13	12	11	10	9	8				3						
	70	69	68	67		63	62	61	60	59	58	57	56	55	54	53																																																																
52	51	50	49			44	43	42	41	39	38	37	36		34																																																																	
73			32	31	29	28	27	26	25	23				19	18																																																																	
			16	15	14	13	12	11	10	9	8				3																																																																	
AVAILABLE	NOT APPLICABLE	34566-4953	G	0	B	ST.GRAY	<table border="1"> <tr><td>72</td><td>71</td><td>70</td><td>69</td><td>68</td><td>67</td><td>66</td><td>65</td><td>64</td><td>63</td><td></td><td>59</td><td></td><td></td><td></td><td></td><td>53</td></tr> <tr><td>52</td><td>51</td><td>50</td><td>49</td><td>48</td><td>47</td><td>46</td><td>45</td><td>44</td><td>43</td><td></td><td>39</td><td></td><td></td><td></td><td></td><td>34</td><td>33</td></tr> <tr><td>73</td><td></td><td></td><td>32</td><td>31</td><td>30</td><td>29</td><td>28</td><td>27</td><td>26</td><td>25</td><td>24</td><td>23</td><td></td><td></td><td></td><td>19</td><td>18</td><td>17</td></tr> <tr><td></td><td></td><td></td><td>16</td><td>15</td><td>14</td><td>13</td><td>12</td><td>11</td><td>10</td><td></td><td>8</td><td>7</td><td></td><td></td><td></td><td>3</td><td>2</td><td>1</td></tr> </table>	72	71	70	69	68	67	66	65	64	63		59					53	52	51	50	49	48	47	46	45	44	43		39					34	33	73			32	31	30	29	28	27	26	25	24	23				19	18	17				16	15	14	13	12	11	10		8	7				3	2	1
72	71	70	69	68	67	66	65	64	63		59					53																																																																
52	51	50	49	48	47	46	45	44	43		39					34	33																																																															
73			32	31	30	29	28	27	26	25	24	23				19	18	17																																																														
			16	15	14	13	12	11	10		8	7				3	2	1																																																														
AVAILABLE	NOT APPLICABLE	34566-4963	G	9	A	BLACK	<table border="1"> <tr><td></td><td></td><td>69</td><td>67</td><td>66</td><td>65</td><td>63</td><td></td><td>60</td><td></td><td>57</td><td>56</td><td></td><td>53</td></tr> <tr><td></td><td></td><td>49</td><td>47</td><td>46</td><td>44</td><td>43</td><td>42</td><td>40</td><td></td><td>37</td><td>36</td><td>35</td><td>33</td></tr> <tr><td>73</td><td></td><td></td><td>31</td><td>30</td><td>29</td><td>28</td><td>27</td><td>26</td><td>24</td><td></td><td>21</td><td>20</td><td>17</td></tr> <tr><td></td><td></td><td></td><td>16</td><td>15</td><td>14</td><td>13</td><td></td><td>11</td><td>10</td><td></td><td></td><td>5</td><td>4</td><td>3</td><td>2</td><td>1</td></tr> </table>			69	67	66	65	63		60		57	56		53			49	47	46	44	43	42	40		37	36	35	33	73			31	30	29	28	27	26	24		21	20	17				16	15	14	13		11	10			5	4	3	2	1														
		69	67	66	65	63		60		57	56		53																																																																			
		49	47	46	44	43	42	40		37	36	35	33																																																																			
73			31	30	29	28	27	26	24		21	20	17																																																																			
			16	15	14	13		11	10			5	4	3	2	1																																																																
AVAILABLE	NOT APPLICABLE	34566-4973	G	9	B	ST.GRAY	<table border="1"> <tr><td></td><td></td><td>68</td><td>67</td><td></td><td>64</td><td>63</td><td></td><td></td><td>59</td><td>58</td><td></td><td></td><td>54</td></tr> <tr><td></td><td></td><td></td><td>46</td><td>45</td><td>44</td><td>43</td><td></td><td></td><td>39</td><td>38</td><td></td><td></td><td></td></tr> <tr><td>73</td><td></td><td>32</td><td>30</td><td>29</td><td>28</td><td>27</td><td></td><td></td><td>23</td><td>22</td><td></td><td></td><td>17</td></tr> <tr><td></td><td></td><td></td><td>15</td><td>13</td><td>12</td><td>10</td><td></td><td></td><td>6</td><td></td><td></td><td></td><td></td><td></td><td></td><td>1</td></tr> </table>			68	67		64	63			59	58			54				46	45	44	43			39	38				73		32	30	29	28	27			23	22			17				15	13	12	10			6							1														
		68	67		64	63			59	58			54																																																																			
			46	45	44	43			39	38																																																																						
73		32	30	29	28	27			23	22			17																																																																			
			15	13	12	10			6							1																																																																

ENTER DESCRIPTION EC NO. UAU2013-0662 DRAWN BY CHKD: APPR:VKOSHY 2012/11/21	QUALITY SYMBOLS	GENERAL TOLERANCES (UNLESS SPECIFIED)	DIMENSION STYLE	SCALE	DESIGN UNITS	THIRD ANGLE PROJECTION	
	∇=0 ∇=0 ∇=0	mm INCH 4 PLACES ± --- ± --- 3 PLACES ± --- ± --- 2 PLACES ± --- ± --- 1 PLACE ± --- ± --- 0 PLACE ± --- ± ---	MM ONLY	1:1	METRIC	DRAWN BY SKRA JENDRANA 2011/02/14 CHECKED BY MVANSLAMBROU 2011/02/14 APPROVED BY	TITLE MX123 66/73/80CKT HRNS CONN ASSY molex
	ANGULAR ± --- DRAFT WHERE APPLICABLE MUST REMAIN WITHIN DIMENSIONS	MATERIAL NO. SEE BOM TABLE	DOCUMENT NO. SD-34566-001	SHEET NO. 56 OF 59			
	THIS DRAWING CONTAINS INFORMATION THAT IS PROPRIETARY TO MOLEX INCORPORATED AND SHOULD NOT BE USED WITHOUT WRITTEN PERMISSION						

STATUS	GM PART #	MATERIAL #	PART/MATERIAL REVISION	WIRE DRESS OPTION	KEY OPTION	COLOR (TPA)	NUMBERS INDICATE CAVITIES OPEN FOR CIRCUITS																																																																																
AVAILABLE	NOT APPLICABLE	34566-4983	G	0	B	ST.GRAY	<table border="1"> <tr><td>72</td><td>70</td><td>68</td><td>66</td><td></td><td></td><td></td><td>60</td><td>59</td><td></td><td></td><td></td><td>55</td><td>54</td><td>53</td></tr> <tr><td>52</td><td>50</td><td>48</td><td>46</td><td>44</td><td></td><td></td><td>40</td><td>39</td><td></td><td></td><td></td><td>35</td><td>34</td><td>33</td></tr> <tr><td></td><td>73</td><td>32</td><td>31</td><td>30</td><td>29</td><td>28</td><td>27</td><td>26</td><td>25</td><td>24</td><td>23</td><td></td><td>19</td><td>18</td><td>17</td></tr> <tr><td></td><td></td><td>16</td><td></td><td></td><td></td><td></td><td></td><td>10</td><td>8</td><td>7</td><td></td><td></td><td>2</td><td>1</td><td></td></tr> </table>	72	70	68	66				60	59				55	54	53	52	50	48	46	44			40	39				35	34	33		73	32	31	30	29	28	27	26	25	24	23		19	18	17			16						10	8	7			2	1																			
72	70	68	66				60	59				55	54	53																																																																									
52	50	48	46	44			40	39				35	34	33																																																																									
	73	32	31	30	29	28	27	26	25	24	23		19	18	17																																																																								
		16						10	8	7			2	1																																																																									
AVAILABLE	NOT APPLICABLE	34566-4993	G	0	A	BLACK	<table border="1"> <tr><td>72</td><td>71</td><td>70</td><td>69</td><td></td><td>67</td><td></td><td>64</td><td>63</td><td></td><td>60</td><td>59</td><td></td><td>56</td><td>55</td><td>54</td><td>53</td></tr> <tr><td>52</td><td>51</td><td></td><td>49</td><td></td><td>47</td><td></td><td>45</td><td>44</td><td>43</td><td>42</td><td>41</td><td></td><td></td><td>36</td><td>34</td><td></td></tr> <tr><td></td><td></td><td></td><td>73</td><td></td><td>32</td><td></td><td>30</td><td>29</td><td>28</td><td>26</td><td></td><td></td><td></td><td></td><td>19</td><td>18</td></tr> <tr><td></td><td></td><td></td><td></td><td></td><td>16</td><td>15</td><td></td><td></td><td>12</td><td>10</td><td></td><td></td><td></td><td>3</td><td></td><td></td></tr> </table>	72	71	70	69		67		64	63		60	59		56	55	54	53	52	51		49		47		45	44	43	42	41			36	34					73		32		30	29	28	26					19	18						16	15			12	10				3														
72	71	70	69		67		64	63		60	59		56	55	54	53																																																																							
52	51		49		47		45	44	43	42	41			36	34																																																																								
			73		32		30	29	28	26					19	18																																																																							
					16	15			12	10				3																																																																									
AVAILABLE	NOT APPLICABLE	34566-5013	G	9	B	ST.GRAY	<table border="1"> <tr><td></td><td></td><td></td><td>68</td><td>67</td><td></td><td>64</td><td>63</td><td></td><td></td><td>59</td><td>58</td><td></td><td>55</td><td>54</td><td></td></tr> <tr><td></td><td></td><td></td><td></td><td></td><td>46</td><td>45</td><td>44</td><td>43</td><td></td><td>39</td><td>38</td><td></td><td>35</td><td></td><td></td></tr> <tr><td></td><td></td><td></td><td>73</td><td></td><td>32</td><td>30</td><td>29</td><td>28</td><td>27</td><td></td><td>23</td><td>22</td><td></td><td>19</td><td>17</td></tr> <tr><td></td><td></td><td></td><td></td><td></td><td>15</td><td>13</td><td>12</td><td></td><td>10</td><td></td><td>6</td><td></td><td></td><td></td><td>1</td></tr> </table>				68	67		64	63			59	58		55	54							46	45	44	43		39	38		35						73		32	30	29	28	27		23	22		19	17						15	13	12		10		6				1																
			68	67		64	63			59	58		55	54																																																																									
					46	45	44	43		39	38		35																																																																										
			73		32	30	29	28	27		23	22		19	17																																																																								
					15	13	12		10		6				1																																																																								
AVAILABLE	NOT APPLICABLE	34566-5023	G	0	C	BLUE	<table border="1"> <tr><td>72</td><td>70</td><td>68</td><td>67</td><td></td><td></td><td>63</td><td>62</td><td></td><td>59</td><td>57</td><td></td><td></td><td></td><td>53</td></tr> <tr><td>52</td><td>51</td><td></td><td>48</td><td>47</td><td>46</td><td>44</td><td>42</td><td>40</td><td>39</td><td>37</td><td>36</td><td></td><td>34</td><td>33</td></tr> <tr><td></td><td>73</td><td></td><td>32</td><td>30</td><td></td><td></td><td>26</td><td>25</td><td>24</td><td>22</td><td>21</td><td>20</td><td></td><td></td></tr> <tr><td></td><td></td><td></td><td>15</td><td>14</td><td></td><td></td><td></td><td>8</td><td>6</td><td>5</td><td>4</td><td></td><td>2</td><td></td></tr> </table>	72	70	68	67			63	62		59	57				53	52	51		48	47	46	44	42	40	39	37	36		34	33		73		32	30			26	25	24	22	21	20						15	14				8	6	5	4		2																					
72	70	68	67			63	62		59	57				53																																																																									
52	51		48	47	46	44	42	40	39	37	36		34	33																																																																									
	73		32	30			26	25	24	22	21	20																																																																											
			15	14				8	6	5	4		2																																																																										
AVAILABLE	NOT APPLICABLE	34566-5033	G	0	A	BLACK	<table border="1"> <tr><td></td><td>70</td><td>69</td><td></td><td></td><td></td><td>63</td><td>62</td><td>61</td><td>60</td><td></td><td>58</td><td>57</td><td>56</td><td>55</td><td>54</td><td>53</td></tr> <tr><td>52</td><td>51</td><td></td><td>49</td><td></td><td></td><td>44</td><td>43</td><td>42</td><td>41</td><td></td><td></td><td>37</td><td>36</td><td>35</td><td>34</td><td>33</td></tr> <tr><td></td><td></td><td></td><td>73</td><td></td><td></td><td>32</td><td></td><td>29</td><td>28</td><td>27</td><td>26</td><td>25</td><td></td><td></td><td>19</td><td>18</td></tr> <tr><td></td><td></td><td></td><td></td><td></td><td></td><td>16</td><td>15</td><td></td><td>13</td><td>12</td><td>11</td><td>10</td><td></td><td></td><td>3</td><td></td></tr> </table>		70	69				63	62	61	60		58	57	56	55	54	53	52	51		49			44	43	42	41			37	36	35	34	33				73			32		29	28	27	26	25			19	18							16	15		13	12	11	10			3													
	70	69				63	62	61	60		58	57	56	55	54	53																																																																							
52	51		49			44	43	42	41			37	36	35	34	33																																																																							
			73			32		29	28	27	26	25			19	18																																																																							
						16	15		13	12	11	10			3																																																																								
AVAILABLE	NOT APPLICABLE	34566-5043	G	0	A	BLACK	<table border="1"> <tr><td></td><td></td><td></td><td></td><td></td><td></td><td></td><td></td><td></td><td></td><td></td><td></td><td></td><td></td><td></td><td></td><td></td></tr> <tr><td></td><td></td><td></td><td></td><td></td><td></td><td></td><td></td><td></td><td></td><td></td><td></td><td></td><td></td><td></td><td></td><td></td></tr> <tr><td></td><td></td><td></td><td>73</td><td></td><td></td><td>31</td><td></td><td></td><td></td><td></td><td></td><td></td><td></td><td></td><td></td><td></td></tr> </table>																																						73			31																																							
			73			31																																																																																	
AVAILABLE	NOT APPLICABLE	34566-5053	G	0	B	ST.GRAY	<table border="1"> <tr><td></td><td></td><td></td><td></td><td></td><td></td><td></td><td></td><td></td><td></td><td></td><td></td><td></td><td></td><td></td><td></td><td></td></tr> <tr><td></td><td></td><td></td><td></td><td></td><td></td><td></td><td></td><td></td><td></td><td></td><td></td><td></td><td></td><td></td><td></td><td></td></tr> <tr><td></td><td></td><td></td><td>73</td><td></td><td></td><td>47</td><td></td><td></td><td></td><td></td><td></td><td></td><td></td><td></td><td>20</td><td>17</td></tr> <tr><td></td><td></td><td></td><td></td><td></td><td></td><td>31</td><td></td><td></td><td></td><td></td><td></td><td></td><td></td><td></td><td></td><td>1</td></tr> </table>																																						73			47									20	17							31										1												
			73			47									20	17																																																																							
						31										1																																																																							
AVAILABLE	NOT APPLICABLE	34566-5063	G	9	H	ST.GRAY	<table border="1"> <tr><td>80</td><td>79</td><td>78</td><td>77</td><td>76</td><td>75</td><td>74</td><td>73</td><td>72</td><td>71</td><td>70</td><td>69</td><td>68</td><td>67</td><td>66</td><td>65</td><td>64</td><td>63</td><td>62</td><td>61</td></tr> <tr><td>60</td><td>59</td><td>58</td><td>57</td><td>56</td><td>55</td><td>54</td><td>53</td><td>52</td><td>51</td><td>50</td><td>49</td><td>48</td><td>47</td><td>46</td><td>45</td><td>44</td><td>43</td><td>42</td><td>41</td></tr> <tr><td>40</td><td>39</td><td>38</td><td>37</td><td></td><td>35</td><td>34</td><td>33</td><td>32</td><td>30</td><td>29</td><td>27</td><td>26</td><td></td><td>24</td><td>23</td><td>22</td><td>21</td><td></td><td></td></tr> <tr><td>20</td><td>19</td><td>18</td><td>17</td><td></td><td></td><td>14</td><td>13</td><td>12</td><td>11</td><td>10</td><td>9</td><td>8</td><td></td><td>6</td><td>5</td><td></td><td>3</td><td>2</td><td></td></tr> </table>	80	79	78	77	76	75	74	73	72	71	70	69	68	67	66	65	64	63	62	61	60	59	58	57	56	55	54	53	52	51	50	49	48	47	46	45	44	43	42	41	40	39	38	37		35	34	33	32	30	29	27	26		24	23	22	21			20	19	18	17			14	13	12	11	10	9	8		6	5		3	2	
80	79	78	77	76	75	74	73	72	71	70	69	68	67	66	65	64	63	62	61																																																																				
60	59	58	57	56	55	54	53	52	51	50	49	48	47	46	45	44	43	42	41																																																																				
40	39	38	37		35	34	33	32	30	29	27	26		24	23	22	21																																																																						
20	19	18	17			14	13	12	11	10	9	8		6	5		3	2																																																																					
AVAILABLE	NOT APPLICABLE	34566-5073	G	9	A	BLACK	<table border="1"> <tr><td>72</td><td>71</td><td>70</td><td>69</td><td>68</td><td>67</td><td>66</td><td>65</td><td>64</td><td>63</td><td>62</td><td>61</td><td>60</td><td>59</td><td>58</td><td>57</td><td>56</td><td>55</td><td>54</td><td>53</td></tr> <tr><td>52</td><td>51</td><td>50</td><td>49</td><td>48</td><td>47</td><td>46</td><td>45</td><td>44</td><td>43</td><td>42</td><td>41</td><td>40</td><td>39</td><td>38</td><td>37</td><td>36</td><td></td><td>34</td><td>33</td></tr> <tr><td></td><td></td><td>73</td><td></td><td>32</td><td>31</td><td>30</td><td>29</td><td>28</td><td>27</td><td>26</td><td></td><td>24</td><td>23</td><td>22</td><td>21</td><td>20</td><td>19</td><td>18</td><td></td></tr> <tr><td></td><td></td><td></td><td></td><td>16</td><td></td><td></td><td>13</td><td>12</td><td>11</td><td>10</td><td>9</td><td>8</td><td></td><td></td><td></td><td></td><td></td><td></td><td>1</td></tr> </table>	72	71	70	69	68	67	66	65	64	63	62	61	60	59	58	57	56	55	54	53	52	51	50	49	48	47	46	45	44	43	42	41	40	39	38	37	36		34	33			73		32	31	30	29	28	27	26		24	23	22	21	20	19	18						16			13	12	11	10	9	8							1
72	71	70	69	68	67	66	65	64	63	62	61	60	59	58	57	56	55	54	53																																																																				
52	51	50	49	48	47	46	45	44	43	42	41	40	39	38	37	36		34	33																																																																				
		73		32	31	30	29	28	27	26		24	23	22	21	20	19	18																																																																					
				16			13	12	11	10	9	8							1																																																																				

ENTER DESCRIPTION EC NO: UAU2013-0662 DRAWN BY: 2012/11/01 CHKD: 2012/11/21 APPR: VKOSHY	QUALITY SYMBOLS	GENERAL TOLERANCES (UNLESS SPECIFIED)	DIMENSION STYLE	SCALE	DESIGN UNITS	THIRD ANGLE PROJECTION
	▽=0	mm INCH	MM ONLY	1:1	METRIC	☉
	▽=0	4 PLACES #--- #---	DRAWN BY DATE			
	▽=0	3 PLACES #--- #---	SKRA JENDRANA 2011/02/14			
	2 PLACES #--- #---	CHECKED BY DATE				
	1 PLACE #--- #---	MVANS LAMBROU 2011/02/14				
	0 PLACE #--- #---	APPROVED BY DATE				
	ANGULAR ±---	MATERIAL NO.	DOCUMENT NO.			
	DRAFT WHERE APPLICABLE MUST REMAIN WITHIN DIMENSIONS	SEE BOM TABLE	SD-34566-001			
		SIZE D	THIS DRAWING CONTAINS INFORMATION THAT IS PROPRIETARY TO MOLEX INCORPORATED AND SHOULD NOT BE USED WITHOUT WRITTEN PERMISSION			

MX123
66/73/80CKT
HRNS CONN ASSY
molex

STATUS	GM PART #	MATERIAL #	PART/MATERIAL REVISION	WIRE DRESS OPTION	KEY OPTION	COLOR (TFA)	NUMBERS INDICATE CAVITIES OPEN FOR CIRCUITS																																																																																			
AVAILABLE	NOT APPLICABLE	34566-5083	G	9	A	BLACK	<table border="1"> <tr><td></td><td>70</td><td>69</td><td></td><td></td><td></td><td></td><td>63</td><td>62</td><td>61</td><td>60</td><td></td><td>58</td><td>57</td><td>56</td><td>55</td><td>54</td><td>53</td></tr> <tr><td>52</td><td>51</td><td>49</td><td></td><td></td><td></td><td></td><td>44</td><td>43</td><td>42</td><td>41</td><td></td><td></td><td>38</td><td>37</td><td></td><td></td><td>34</td></tr> <tr><td></td><td></td><td></td><td>32</td><td></td><td></td><td></td><td>29</td><td>28</td><td>27</td><td>26</td><td></td><td></td><td>23</td><td></td><td></td><td>19</td><td>18</td></tr> <tr><td></td><td></td><td></td><td>73</td><td>16</td><td>15</td><td>13</td><td>12</td><td>11</td><td>10</td><td></td><td></td><td>8</td><td></td><td></td><td></td><td>3</td><td></td></tr> </table>		70	69					63	62	61	60		58	57	56	55	54	53	52	51	49					44	43	42	41			38	37			34				32				29	28	27	26			23			19	18				73	16	15	13	12	11	10			8				3												
	70	69					63	62	61	60		58	57	56	55	54	53																																																																									
52	51	49					44	43	42	41			38	37			34																																																																									
			32				29	28	27	26			23			19	18																																																																									
			73	16	15	13	12	11	10			8				3																																																																										
AVAILABLE	NOT APPLICABLE	34566-5093	G	0	B	ST.GRAY	<table border="1"> <tr><td>72</td><td>71</td><td>70</td><td>69</td><td>68</td><td>67</td><td>66</td><td>65</td><td>64</td><td>63</td><td>62</td><td>61</td><td>60</td><td>59</td><td>58</td><td>57</td><td>56</td><td>55</td><td>54</td><td>53</td></tr> <tr><td>52</td><td>51</td><td>50</td><td>49</td><td>48</td><td>47</td><td>46</td><td>45</td><td>44</td><td>43</td><td>42</td><td>41</td><td>40</td><td>39</td><td>38</td><td>37</td><td>36</td><td>35</td><td>34</td><td>33</td></tr> <tr><td></td><td></td><td></td><td></td><td></td><td></td><td></td><td>29</td><td>27</td><td></td><td></td><td></td><td></td><td></td><td>23</td><td>22</td><td>21</td><td></td><td></td><td>18</td></tr> <tr><td></td><td></td><td></td><td>73</td><td>16</td><td>15</td><td>14</td><td>13</td><td></td><td></td><td></td><td></td><td>8</td><td>7</td><td>6</td><td>5</td><td>4</td><td>3</td><td></td><td></td></tr> </table>	72	71	70	69	68	67	66	65	64	63	62	61	60	59	58	57	56	55	54	53	52	51	50	49	48	47	46	45	44	43	42	41	40	39	38	37	36	35	34	33								29	27						23	22	21			18				73	16	15	14	13					8	7	6	5	4	3					
72	71	70	69	68	67	66	65	64	63	62	61	60	59	58	57	56	55	54	53																																																																							
52	51	50	49	48	47	46	45	44	43	42	41	40	39	38	37	36	35	34	33																																																																							
							29	27						23	22	21			18																																																																							
			73	16	15	14	13					8	7	6	5	4	3																																																																									
AVAILABLE	NOT APPLICABLE	34566-5113	G	0	A	BLACK	<table border="1"> <tr><td>72</td><td>71</td><td>70</td><td>69</td><td>68</td><td>67</td><td>66</td><td></td><td>64</td><td>63</td><td>62</td><td></td><td>60</td><td>59</td><td></td><td></td><td></td><td>55</td><td>54</td><td>53</td></tr> <tr><td>52</td><td></td><td>49</td><td>48</td><td></td><td></td><td></td><td></td><td>44</td><td>43</td><td>42</td><td>41</td><td>40</td><td>39</td><td></td><td></td><td></td><td>35</td><td>34</td><td>33</td></tr> <tr><td></td><td></td><td></td><td>32</td><td></td><td></td><td></td><td></td><td>29</td><td>27</td><td></td><td>25</td><td>24</td><td>23</td><td></td><td></td><td></td><td>19</td><td>18</td><td>17</td></tr> <tr><td></td><td></td><td></td><td>73</td><td>16</td><td></td><td></td><td></td><td>13</td><td>12</td><td>11</td><td></td><td>9</td><td>8</td><td>7</td><td>6</td><td>5</td><td>4</td><td>3</td><td>2</td><td>1</td></tr> </table>	72	71	70	69	68	67	66		64	63	62		60	59				55	54	53	52		49	48					44	43	42	41	40	39				35	34	33				32					29	27		25	24	23				19	18	17				73	16				13	12	11		9	8	7	6	5	4	3	2	1		
72	71	70	69	68	67	66		64	63	62		60	59				55	54	53																																																																							
52		49	48					44	43	42	41	40	39				35	34	33																																																																							
			32					29	27		25	24	23				19	18	17																																																																							
			73	16				13	12	11		9	8	7	6	5	4	3	2	1																																																																						
AVAILABLE	NOT APPLICABLE	34566-5123	G	9	C	BLUE	<table border="1"> <tr><td>72</td><td></td><td>70</td><td>68</td><td>67</td><td>66</td><td></td><td></td><td>63</td><td>62</td><td></td><td></td><td>59</td><td></td><td>57</td><td></td><td></td><td></td><td></td><td>53</td></tr> <tr><td>52</td><td>51</td><td></td><td>48</td><td>47</td><td>46</td><td>45</td><td>44</td><td></td><td></td><td></td><td></td><td>40</td><td>39</td><td>38</td><td>37</td><td>36</td><td></td><td></td><td>34</td><td>33</td></tr> <tr><td></td><td></td><td></td><td>32</td><td></td><td>30</td><td></td><td></td><td>27</td><td>26</td><td>25</td><td>24</td><td></td><td></td><td>22</td><td>21</td><td>20</td><td></td><td></td><td>19</td><td>18</td></tr> <tr><td></td><td></td><td></td><td>73</td><td></td><td>15</td><td>14</td><td></td><td></td><td></td><td>10</td><td>9</td><td>8</td><td></td><td>6</td><td>5</td><td>4</td><td></td><td></td><td>2</td><td></td></tr> </table>	72		70	68	67	66			63	62			59		57					53	52	51		48	47	46	45	44					40	39	38	37	36			34	33				32		30			27	26	25	24			22	21	20			19	18				73		15	14				10	9	8		6	5	4			2	
72		70	68	67	66			63	62			59		57					53																																																																							
52	51		48	47	46	45	44					40	39	38	37	36			34	33																																																																						
			32		30			27	26	25	24			22	21	20			19	18																																																																						
			73		15	14				10	9	8		6	5	4			2																																																																							
AVAILABLE	NOT APPLICABLE	34566-5133	G	9	B	ST.GRAY	<table border="1"> <tr><td>72</td><td>71</td><td>70</td><td>68</td><td>67</td><td>66</td><td></td><td></td><td>62</td><td>61</td><td>60</td><td>59</td><td>58</td><td>57</td><td>56</td><td>55</td><td>54</td><td>53</td></tr> <tr><td>52</td><td>51</td><td>50</td><td>48</td><td>47</td><td>46</td><td></td><td></td><td>42</td><td>41</td><td>40</td><td>39</td><td>38</td><td>37</td><td>36</td><td>35</td><td>34</td><td>33</td></tr> <tr><td></td><td></td><td></td><td>32</td><td>31</td><td>30</td><td>29</td><td>28</td><td>27</td><td>26</td><td>25</td><td>24</td><td>23</td><td></td><td></td><td></td><td></td><td></td></tr> <tr><td></td><td></td><td></td><td>73</td><td>16</td><td>15</td><td>14</td><td>13</td><td></td><td></td><td>10</td><td>9</td><td>8</td><td></td><td></td><td></td><td></td><td></td></tr> </table>	72	71	70	68	67	66			62	61	60	59	58	57	56	55	54	53	52	51	50	48	47	46			42	41	40	39	38	37	36	35	34	33				32	31	30	29	28	27	26	25	24	23									73	16	15	14	13			10	9	8																
72	71	70	68	67	66			62	61	60	59	58	57	56	55	54	53																																																																									
52	51	50	48	47	46			42	41	40	39	38	37	36	35	34	33																																																																									
			32	31	30	29	28	27	26	25	24	23																																																																														
			73	16	15	14	13			10	9	8																																																																														
AVAILABLE	NOT APPLICABLE	34566-5143	G	0	C	BLUE	<table border="1"> <tr><td>72</td><td>70</td><td>68</td><td>67</td><td>66</td><td></td><td></td><td>63</td><td>62</td><td></td><td></td><td>59</td><td>57</td><td></td><td></td><td></td><td></td><td></td><td></td><td>53</td></tr> <tr><td>52</td><td>51</td><td></td><td>48</td><td>47</td><td>46</td><td></td><td>44</td><td>42</td><td></td><td></td><td>40</td><td>39</td><td></td><td>37</td><td>36</td><td></td><td></td><td></td><td>34</td><td>33</td></tr> <tr><td></td><td></td><td></td><td>32</td><td></td><td>30</td><td></td><td></td><td>26</td><td>25</td><td>24</td><td></td><td>22</td><td>21</td><td>20</td><td></td><td></td><td></td><td></td><td>19</td><td>18</td></tr> <tr><td></td><td></td><td></td><td>73</td><td></td><td>15</td><td>14</td><td></td><td></td><td></td><td>10</td><td>9</td><td>8</td><td></td><td>6</td><td>5</td><td>4</td><td></td><td></td><td>2</td><td></td></tr> </table>	72	70	68	67	66			63	62			59	57							53	52	51		48	47	46		44	42			40	39		37	36				34	33				32		30			26	25	24		22	21	20					19	18				73		15	14				10	9	8		6	5	4			2	
72	70	68	67	66			63	62			59	57							53																																																																							
52	51		48	47	46		44	42			40	39		37	36				34	33																																																																						
			32		30			26	25	24		22	21	20					19	18																																																																						
			73		15	14				10	9	8		6	5	4			2																																																																							
AVAILABLE	NOT APPLICABLE	34566-5153	G	0	A	BLACK	<table border="1"> <tr><td></td><td>70</td><td>69</td><td></td><td></td><td></td><td></td><td></td><td>63</td><td>62</td><td>61</td><td>60</td><td></td><td>58</td><td>57</td><td>56</td><td>55</td><td>54</td><td>53</td></tr> <tr><td>52</td><td>51</td><td>49</td><td></td><td></td><td></td><td></td><td></td><td>44</td><td>43</td><td>42</td><td>41</td><td></td><td></td><td>37</td><td>36</td><td>35</td><td>34</td><td>33</td></tr> <tr><td></td><td></td><td></td><td>32</td><td></td><td></td><td></td><td></td><td>29</td><td>28</td><td>27</td><td>26</td><td>25</td><td></td><td></td><td></td><td></td><td>19</td><td>18</td></tr> <tr><td></td><td></td><td></td><td>73</td><td>16</td><td>15</td><td>13</td><td>12</td><td>11</td><td>10</td><td></td><td></td><td></td><td></td><td></td><td></td><td></td><td>3</td><td></td></tr> </table>		70	69						63	62	61	60		58	57	56	55	54	53	52	51	49						44	43	42	41			37	36	35	34	33				32					29	28	27	26	25					19	18				73	16	15	13	12	11	10								3								
	70	69						63	62	61	60		58	57	56	55	54	53																																																																								
52	51	49						44	43	42	41			37	36	35	34	33																																																																								
			32					29	28	27	26	25					19	18																																																																								
			73	16	15	13	12	11	10								3																																																																									
AVAILABLE	NOT APPLICABLE	34566-5163	G	9	A	BLACK	<table border="1"> <tr><td></td><td></td><td>69</td><td>67</td><td>65</td><td>63</td><td></td><td></td><td>60</td><td></td><td></td><td></td><td></td><td>57</td><td>56</td><td></td><td></td><td></td><td></td><td>53</td></tr> <tr><td></td><td></td><td>49</td><td>47</td><td></td><td>44</td><td>43</td><td></td><td>40</td><td></td><td></td><td></td><td></td><td>37</td><td>36</td><td>35</td><td></td><td></td><td></td><td>33</td></tr> <tr><td></td><td></td><td></td><td>31</td><td>30</td><td>29</td><td>28</td><td></td><td>24</td><td></td><td></td><td></td><td></td><td>21</td><td>20</td><td></td><td></td><td></td><td></td><td>17</td></tr> <tr><td></td><td></td><td></td><td>73</td><td>16</td><td>15</td><td>14</td><td></td><td></td><td>11</td><td>10</td><td></td><td></td><td></td><td></td><td>5</td><td>4</td><td>3</td><td>2</td><td>1</td></tr> </table>			69	67	65	63			60					57	56					53			49	47		44	43		40					37	36	35				33				31	30	29	28		24					21	20					17				73	16	15	14			11	10					5	4	3	2	1			
		69	67	65	63			60					57	56					53																																																																							
		49	47		44	43		40					37	36	35				33																																																																							
			31	30	29	28		24					21	20					17																																																																							
			73	16	15	14			11	10					5	4	3	2	1																																																																							
AVAILABLE	NOT APPLICABLE	34566-5173	G	9	B	ST.GRAY	<table border="1"> <tr><td></td><td></td><td>68</td><td>67</td><td></td><td>64</td><td>63</td><td></td><td></td><td></td><td></td><td>59</td><td>57</td><td></td><td></td><td></td><td></td><td></td><td></td><td></td></tr> <tr><td></td><td></td><td></td><td>46</td><td>45</td><td></td><td>43</td><td></td><td></td><td></td><td></td><td>39</td><td>37</td><td></td><td></td><td></td><td></td><td></td><td></td><td></td></tr> <tr><td></td><td></td><td></td><td>32</td><td>30</td><td>29</td><td>28</td><td>27</td><td></td><td></td><td></td><td></td><td>21</td><td></td><td></td><td></td><td></td><td></td><td></td><td></td></tr> <tr><td></td><td></td><td></td><td>73</td><td></td><td></td><td></td><td></td><td>10</td><td></td><td></td><td></td><td></td><td>6</td><td>5</td><td>4</td><td>3</td><td></td><td></td><td></td></tr> </table>			68	67		64	63					59	57											46	45		43					39	37											32	30	29	28	27					21											73					10					6	5	4	3						
		68	67		64	63					59	57																																																																														
			46	45		43					39	37																																																																														
			32	30	29	28	27					21																																																																														
			73					10					6	5	4	3																																																																										

ENTER DESCRIPTION EC NO. UAU2013-0662 DRAWN BY CHKD: APPR:VKOSHY 2012/11/21 2012/11/21	QUALITY SYMBOLS	GENERAL TOLERANCES (UNLESS SPECIFIED)	DIMENSION STYLE	SCALE	DESIGN UNITS	THIRD ANGLE PROJECTION	
	∇=0 ∇=0 ∇=0	mm INCH 4 PLACES # --- ± --- 3 PLACES # --- ± --- 2 PLACES # --- ± --- 1 PLACE # --- ± --- 0 PLACE # --- ± ---	MM ONLY	1:1	METRIC	SKRA JENDRANA 2011/02/14 MYANS LAMBROU 2011/02/14	MX123 66/73/80CKT HRNS CONN ASSY
	ANGULAR ± ---° DRAFT WHERE APPLICABLE MUST REMAIN WITHIN DIMENSIONS	DRAWN BY DATE CHECKED BY DATE APPROVED BY DATE	MATERIAL NO. SEE BOM TABLE	DOCUMENT NO. SD-34566-001	SHEET NO. 58 OF 59		
	THIS DRAWING CONTAINS INFORMATION THAT IS PROPRIETARY TO MOLEX INCORPORATED AND SHOULD NOT BE USED WITHOUT WRITTEN PERMISSION						

STATUS	GM PART #	MATERIAL #	PART/MATERIAL REVISION	WIRE DRESS OPTION	KEY OPTION	COLOR (TPA)	NUMBERS INDICATE CAVITIES OPEN FOR CIRCUITS																																																																																					
AVAILABLE	NOT APPLICABLE	34566-5183	G	0	B	ST.GRAY	<table border="1"> <tr><td></td><td></td><td></td><td>68</td><td>67</td><td></td><td>64</td><td></td><td></td><td></td><td>59</td><td>58</td><td></td><td></td><td>54</td></tr> <tr><td></td><td></td><td></td><td></td><td></td><td>46</td><td>45</td><td>44</td><td></td><td></td><td>39</td><td>38</td><td></td><td></td><td></td></tr> <tr><td></td><td>73</td><td></td><td>32</td><td></td><td>30</td><td>29</td><td>28</td><td>27</td><td></td><td></td><td>23</td><td>22</td><td></td><td>17</td></tr> <tr><td></td><td></td><td></td><td></td><td></td><td></td><td></td><td>12</td><td></td><td>10</td><td>8</td><td></td><td></td><td></td><td>1</td></tr> </table>				68	67		64				59	58			54						46	45	44			39	38					73		32		30	29	28	27			23	22		17								12		10	8				1																									
			68	67		64				59	58			54																																																																														
					46	45	44			39	38																																																																																	
	73		32		30	29	28	27			23	22		17																																																																														
							12		10	8				1																																																																														
AVAILABLE	NOT APPLICABLE	34566-5193	G	0	A	BLACK	<table border="1"> <tr><td></td><td></td><td>70</td><td>69</td><td></td><td></td><td></td><td></td><td>63</td><td>62</td><td>61</td><td>60</td><td></td><td>58</td><td>57</td><td>56</td><td>55</td><td>54</td><td>53</td></tr> <tr><td>52</td><td>51</td><td></td><td>49</td><td></td><td></td><td></td><td></td><td>44</td><td>43</td><td>42</td><td>41</td><td></td><td></td><td></td><td>37</td><td>36</td><td></td><td>34</td></tr> <tr><td></td><td></td><td></td><td></td><td>32</td><td></td><td></td><td></td><td>29</td><td>28</td><td>27</td><td>26</td><td></td><td></td><td></td><td></td><td></td><td>19</td><td>18</td><td>17</td></tr> <tr><td></td><td>73</td><td></td><td></td><td>16</td><td>15</td><td></td><td></td><td>13</td><td>12</td><td>11</td><td>10</td><td></td><td></td><td></td><td></td><td></td><td>3</td><td>2</td><td>1</td></tr> </table>			70	69					63	62	61	60		58	57	56	55	54	53	52	51		49					44	43	42	41				37	36		34					32				29	28	27	26						19	18	17		73			16	15			13	12	11	10						3	2	1							
		70	69					63	62	61	60		58	57	56	55	54	53																																																																										
52	51		49					44	43	42	41				37	36		34																																																																										
				32				29	28	27	26						19	18	17																																																																									
	73			16	15			13	12	11	10						3	2	1																																																																									
AVAILABLE	NOT APPLICABLE	34566-5213	G	0	A	BLACK	<table border="1"> <tr><td>72</td><td>71</td><td>70</td><td>69</td><td>68</td><td>67</td><td>66</td><td>65</td><td>64</td><td>63</td><td>62</td><td>61</td><td>60</td><td>59</td><td></td><td></td><td>55</td><td>54</td><td>53</td></tr> <tr><td>52</td><td></td><td></td><td>49</td><td>48</td><td></td><td></td><td></td><td>44</td><td>43</td><td>42</td><td>41</td><td>40</td><td>39</td><td></td><td></td><td></td><td>35</td><td>34</td><td>33</td></tr> <tr><td></td><td></td><td></td><td></td><td></td><td>32</td><td></td><td></td><td>29</td><td>27</td><td></td><td>25</td><td>24</td><td>23</td><td></td><td></td><td></td><td></td><td>19</td><td>18</td><td>17</td></tr> <tr><td></td><td>73</td><td></td><td></td><td></td><td>16</td><td></td><td></td><td>13</td><td>12</td><td>11</td><td></td><td>9</td><td>8</td><td>7</td><td>6</td><td>5</td><td>4</td><td>3</td><td>2</td><td>1</td></tr> </table>	72	71	70	69	68	67	66	65	64	63	62	61	60	59			55	54	53	52			49	48				44	43	42	41	40	39				35	34	33						32			29	27		25	24	23					19	18	17		73				16			13	12	11		9	8	7	6	5	4	3	2	1				
72	71	70	69	68	67	66	65	64	63	62	61	60	59			55	54	53																																																																										
52			49	48				44	43	42	41	40	39				35	34	33																																																																									
					32			29	27		25	24	23					19	18	17																																																																								
	73				16			13	12	11		9	8	7	6	5	4	3	2	1																																																																								
AVAILABLE	NOT APPLICABLE	34566-5223	G	0	C	BLUE	<table border="1"> <tr><td>72</td><td>70</td><td></td><td></td><td>67</td><td>66</td><td></td><td></td><td>63</td><td>62</td><td></td><td></td><td>59</td><td>57</td><td></td><td></td><td></td><td></td><td>54</td><td>53</td></tr> <tr><td>52</td><td>51</td><td></td><td></td><td>48</td><td>46</td><td></td><td></td><td>44</td><td>42</td><td></td><td></td><td>40</td><td>39</td><td></td><td></td><td></td><td></td><td>34</td><td>33</td></tr> <tr><td></td><td></td><td></td><td></td><td></td><td>32</td><td></td><td></td><td>30</td><td></td><td></td><td></td><td>26</td><td>25</td><td></td><td></td><td></td><td></td><td>22</td><td>21</td><td>17</td></tr> <tr><td></td><td>73</td><td></td><td></td><td></td><td>15</td><td>14</td><td></td><td></td><td></td><td></td><td></td><td>10</td><td>9</td><td></td><td></td><td></td><td></td><td>6</td><td>5</td><td>4</td></tr> </table>	72	70			67	66			63	62			59	57					54	53	52	51			48	46			44	42			40	39					34	33						32			30				26	25					22	21	17		73				15	14						10	9					6	5	4			
72	70			67	66			63	62			59	57					54	53																																																																									
52	51			48	46			44	42			40	39					34	33																																																																									
					32			30				26	25					22	21	17																																																																								
	73				15	14						10	9					6	5	4																																																																								
AVAILABLE	NOT APPLICABLE	34566-5233	G	0	C	BLUE	<table border="1"> <tr><td>72</td><td>70</td><td></td><td></td><td>68</td><td>67</td><td>66</td><td></td><td>63</td><td>62</td><td></td><td></td><td>59</td><td>57</td><td>56</td><td>55</td><td></td><td></td><td>54</td><td>53</td></tr> <tr><td>52</td><td>51</td><td></td><td></td><td>48</td><td>47</td><td>46</td><td></td><td>44</td><td>42</td><td></td><td></td><td>40</td><td>39</td><td>38</td><td></td><td></td><td></td><td>34</td><td>33</td></tr> <tr><td></td><td></td><td></td><td></td><td></td><td>32</td><td></td><td></td><td>30</td><td></td><td></td><td></td><td>26</td><td>25</td><td></td><td></td><td></td><td></td><td>22</td><td>21</td><td>19</td><td>18</td></tr> <tr><td></td><td>73</td><td></td><td></td><td></td><td>15</td><td>14</td><td></td><td></td><td></td><td></td><td></td><td>10</td><td>9</td><td></td><td></td><td></td><td></td><td>6</td><td>5</td><td>4</td><td>3</td></tr> </table>	72	70			68	67	66		63	62			59	57	56	55			54	53	52	51			48	47	46		44	42			40	39	38				34	33						32			30				26	25					22	21	19	18		73				15	14						10	9					6	5	4	3	
72	70			68	67	66		63	62			59	57	56	55			54	53																																																																									
52	51			48	47	46		44	42			40	39	38				34	33																																																																									
					32			30				26	25					22	21	19	18																																																																							
	73				15	14						10	9					6	5	4	3																																																																							
(F80) AVAILABLE	NOT APPLICABLE	34566-5243	G	0	C	BLUE	<table border="1"> <tr><td>72</td><td>71</td><td>70</td><td>69</td><td>68</td><td>67</td><td>66</td><td>65</td><td>64</td><td>63</td><td>62</td><td>61</td><td>60</td><td>59</td><td>58</td><td>57</td><td>56</td><td>55</td><td>54</td><td>53</td></tr> <tr><td>51</td><td>50</td><td>49</td><td>48</td><td></td><td></td><td>46</td><td>45</td><td>44</td><td>43</td><td>42</td><td>41</td><td>40</td><td>39</td><td>38</td><td></td><td></td><td>36</td><td>35</td><td>34</td><td>33</td></tr> <tr><td></td><td></td><td></td><td></td><td></td><td></td><td>31</td><td>30</td><td>29</td><td>28</td><td>27</td><td>26</td><td>25</td><td></td><td></td><td></td><td></td><td>22</td><td>21</td><td>20</td><td>19</td><td>18</td><td>17</td></tr> <tr><td></td><td>73</td><td></td><td></td><td></td><td></td><td>16</td><td>15</td><td>14</td><td></td><td></td><td></td><td></td><td>9</td><td>7</td><td>6</td><td>5</td><td>4</td><td>3</td><td>2</td><td>1</td></tr> </table>	72	71	70	69	68	67	66	65	64	63	62	61	60	59	58	57	56	55	54	53	51	50	49	48			46	45	44	43	42	41	40	39	38			36	35	34	33							31	30	29	28	27	26	25					22	21	20	19	18	17		73					16	15	14					9	7	6	5	4	3	2	1
72	71	70	69	68	67	66	65	64	63	62	61	60	59	58	57	56	55	54	53																																																																									
51	50	49	48			46	45	44	43	42	41	40	39	38			36	35	34	33																																																																								
						31	30	29	28	27	26	25					22	21	20	19	18	17																																																																						
	73					16	15	14					9	7	6	5	4	3	2	1																																																																								
(F80) AVAILABLE	NOT APPLICABLE	34566-5253	G	0	B	ST.GRAY	<table border="1"> <tr><td></td><td></td><td></td><td></td><td></td><td>67</td><td>66</td><td></td><td>63</td><td></td><td></td><td></td><td>59</td><td>58</td><td>57</td><td>56</td><td>55</td><td></td><td></td><td>54</td><td>53</td></tr> <tr><td></td><td></td><td>50</td><td>49</td><td>48</td><td></td><td>46</td><td>45</td><td>43</td><td></td><td></td><td></td><td>39</td><td>38</td><td>37</td><td>36</td><td>35</td><td></td><td></td><td>34</td><td>33</td></tr> <tr><td></td><td></td><td></td><td></td><td></td><td></td><td></td><td>29</td><td>27</td><td></td><td></td><td></td><td>23</td><td>22</td><td>21</td><td></td><td></td><td></td><td></td><td>18</td><td></td></tr> <tr><td></td><td>73</td><td></td><td></td><td></td><td>16</td><td>15</td><td>14</td><td>13</td><td></td><td></td><td></td><td>8</td><td>7</td><td>6</td><td>5</td><td>4</td><td>3</td><td></td><td></td><td></td></tr> </table>						67	66		63				59	58	57	56	55			54	53			50	49	48		46	45	43				39	38	37	36	35			34	33								29	27				23	22	21					18			73				16	15	14	13				8	7	6	5	4	3				
					67	66		63				59	58	57	56	55			54	53																																																																								
		50	49	48		46	45	43				39	38	37	36	35			34	33																																																																								
							29	27				23	22	21					18																																																																									
	73				16	15	14	13				8	7	6	5	4	3																																																																											

ENTER DESCRIPTION ELEC NO: UAU2013-0662 DRAWN BY: 2012/11/01 CHKD: 2012/11/21 APPR: WKSHY	QUALITY SYMBOLS	GENERAL TOLERANCES (UNLESS SPECIFIED)	DIMENSION STYLE	SCALE	DESIGN UNITS	THIRD ANGLE PROJECTION
	∇=0 ∇=0 ∇=0	mm INCH 4 PLACES #---#--- 3 PLACES #---#--- 2 PLACES #---#--- 1 PLACE #---#--- 0 PLACE #---#---	MM ONLY 1:1 METRIC	DRAWN BY: SKRA JENDRANA DATE: 2011/02/14 CHECKED BY: MVANSLAMBROU DATE: 2011/02/14 APPROVED BY:	TITLE: MX123 66/73/80CKT HRNS CONN ASSY molex	MATERIAL NO: SEE BOM DOCUMENT NO: SD-34566-001