

ITEM ①		ITEM ②		ITEM ③
PART NUMBER	HANDLE	COLOR	BODY	CONTACT SPRING
108-1081-001	NYLON	WHITE	BRASS NICKEL PL .0001 MIN	NICKEL SILVER NICKEL PL .0001 MIN
108-1082-001		RED		
108-1083-001		BLACK		
108-1084-001		GREEN		
108-1085-001				
108-1086-001		ORANGE		
108-1087-001		YELLOW		
108-1088-001		BROWN		
108-1089-001				
108-1090-001		BLUE		
108-1091-001				
108-1092-001		VIOLET		
108-1093-001		GRAY		
108-1094-001				
108-1095-001				
108-1096-001				
108-1097-001				
108-1098-001				
108-1099-001				
108-1100-001				

DRAWING NO.
B-108-1081/1100-001

0	REVISIONS	
ENGINEERING RELEASE		
1a	10-11-94	RH SWC TAK RJB PAH 10-14-94 ECN 42746
VERSION UPDATE		

* REVISION NUMBER FOLLOWED BY AN ALPHA *		
* CHARACTER INDICATES DRAWING CLARIFI-		
* CATION OR PART NUMBER ADDITION ONLY. *		

1b	5-9-95	RH DM RJB ECN 43056

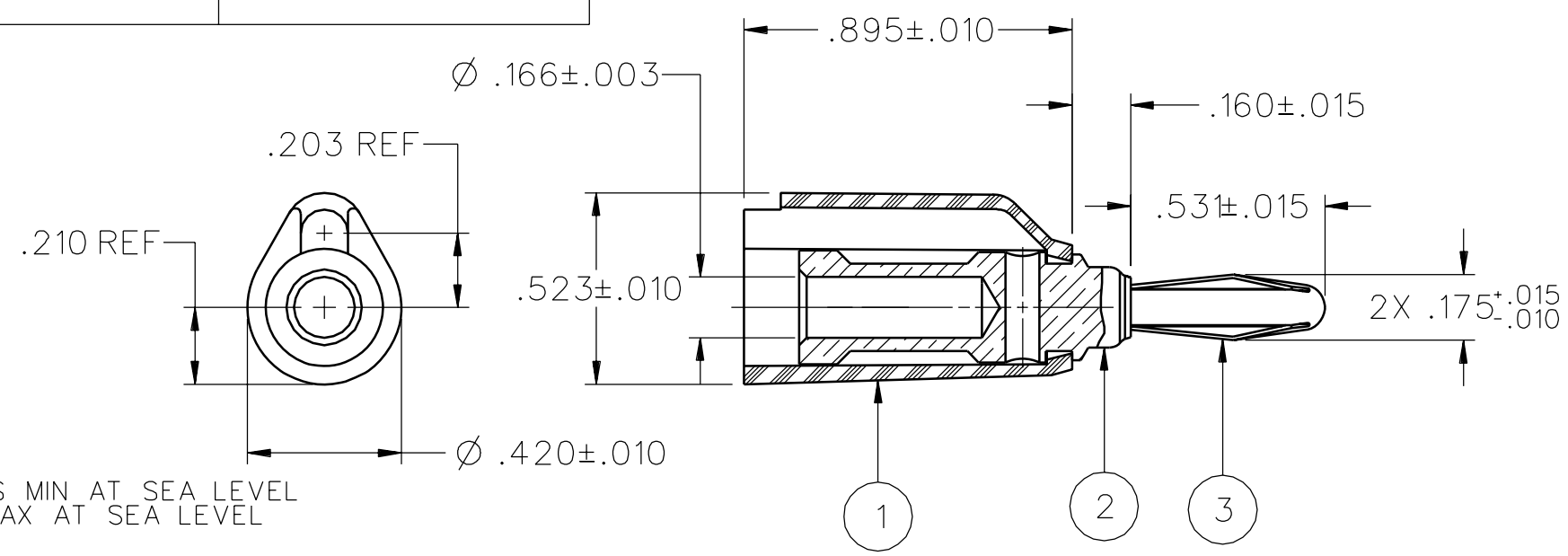

NOTES:

1. SPECIFICATIONS:

ELECTRICAL:

CURRENT RATING: 15 AMPS DC MINIMUM
DIELECTRIC WITHSTANDING VOLTAGE: 3500 VRMS MIN AT SEA LEVEL
RECOMMENDED WORKING VOLTAGE: 1750 VRMS MAX AT SEA LEVEL
INSULATION RESISTANCE: 5000 MEGOHMS MIN
CONTACT RESISTANCE: 10 MILLIOHMS MAXIMUM

MECHANICAL:

INSERTION/WITHDRAWAL FORCE: 1.0 - 12.0 POUNDS
CONTACT SPRING RETENTION FORCE: 25 POUNDS MINIMUM
WIRE ACCEPTABILITY: 16 AWG OR SMALLER
WIRE ATTACHMENT: SOLDER OR SOLDERLESS USING SNAP ON HANDLE
MATING BANANA JACK DIAMETER: .166 NOMINAL
DURABILITY: 1000 CYCLES MINIMUM

ENVIRONMENTAL:

(MEETS OR EXCEEDS THE APPLICABLE PARAGRAPH OF MIL-C-28901)
OPERATING TEMPERATURE: -55 DEG C TO 85 DEG C.
TEMPERATURE RISE AT RATED CURRENT: 10 DEG C MAXIMUM
CORROSION: MIL-STD-1344, METHOD 1001, CONDITION B
SHOCK: MIL-STD-1344, METHOD 2004, CONDITION G
VIBRATION: MIL-STD-1344, METHOD 2005, CONDITION I
HUMIDITY: MIL-STD-1344, METHOD 1002, CONDITION B

CUSTOMER DRAWING

THIS DRAWING TO BE INTERPRETED
PER ASME Y 14.5M - 1994

"μSTATION"

COMPANY CONFIDENTIAL

TOLERANCE UNLESS OTHERWISE SPECIFIED		DRAWN BY	DATE
DECIMALS	mm	SWC	4-20-94
.XX	_____	CHECKED BY	DATE
.XXX	_____	TAK	10-11-94
MATL	_____	APPROVED BY	DATE
FINISH	_____	RJB	10-12-94
		RELEASE DATE	10-14-94
		U/M	INCH
		SCALE	2:1

EMERSON Network Power

Connectivity Solutions
P.O. Box 1732
Waseca, MN 56093
1-800-247-8256

TITLE: ASSEMBLY, BANANA PLUG, ROUND BODY, SOLDER OR SOLDERLESS

SHEET 2 OF 2

DRAWING NO. B-108-1081/1100-001