

5

4

3

2

1

受控 CONTROLLED DOCUMENT				
编号 P/N	CP1094-U-CUST	版本 Rev	02	日期 Rel'd Date
				Aug4,11

DRAWING NO. CP1094U-CUST	
REVISIONS	
01	OFFICIAL RELEASE
	03-20-09 T W B Y T
02	RELEASE FOR SUPPLIER ALTER
	07-27-11 Y G Y G M L <i>Lin Ma</i> 2011.07.28 14:00:00 -0800

D



Description: BNC,Front Mount Bulkhead Jack, BeCu Contact  
 Part No: CP1094U  
 Application: PCB  
 Crimp Tool: N/A  
 Impedance: 50 Ohms  
 Frequency Range: 0-4 GHz  
 Material: Body Brass Nickel plated  
 Contact Becu Gold plated  
 Insulotor PTFE  
 Nut SK7 Nickel plated  
 Lug Brass Nickel plated  
 RoHS Compliance: Yes  
 Technical Detail: Refer to Emerson Document P/N 27-0000

C

D

C

B

B

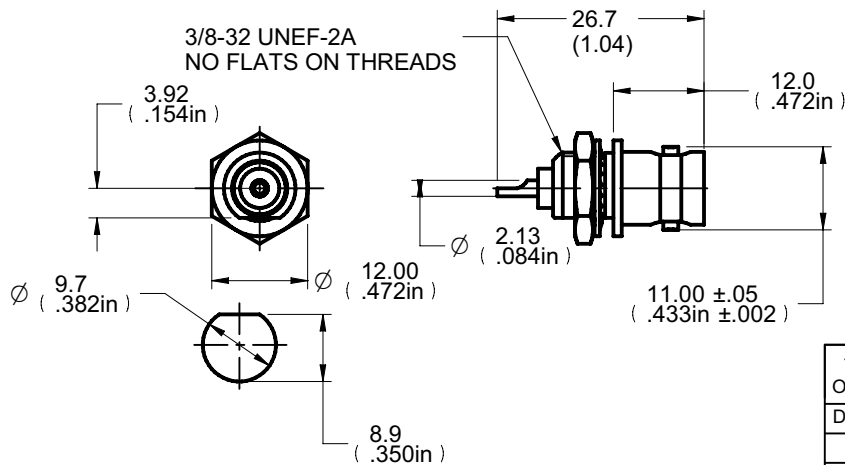

**DIM OUTLINE**

**CUSTOMER COPY**

A

A

TOLERANCE UNLESS OTHERWISE SPECIFIED		DRAWN BY YUGE HU	DATE 07-27-11
DECIMALS	mm	CHECKED BY YUGE HU	DATE 07-27-11
X	± 0.5	APPROVED BY LIN MA	DATE 07-27-11
X.X	± 0.3		
X.XX	± 0.1		
ANGLES	± 0.5°	U/M mm	

		<b>Connectivity Solutions</b>	
TITLE BNC,FRONT MOUNT BULKHEAD JACK, BECU CONTACT			

THIS DRAWING WAS PRODUCED BY COMPUTER, DO NOT SCALE DRAWING OR UPDATE MANUALLY.		SHEET 1 OF 1	DRAWING NO. CP1094U-CUST	SIZE A
---	--	-----------------	-----------------------------	-----------

5

4

3

2

1