

TECHNICAL CHARACTERISTICS

MATERIAL
 INSULATOR: PA 6T
 FLAMABILITY RATING: UL94-V0
 COLOR: BLACK
 CONTACT MATERIAL: COPPER ALLOYS
 CONTACT TYPE: STAMPED
 CONTACT PLATING: GOLD
 QUALITY CLASS: 3 AS PER CECC 75 301-802
 PITCH: 2.54MM

ENVIRONMENTAL
 OPERATING TEMPERATURE: -40 UP TO 125°C
 COMPLIANCE: LEAD FREE AND ROHS

ELECTRICAL
 CURRENT RATING: 3A MAX
 WORKING VOLTAGE: 250V AC
 INSULATOR RESISTANCE: >1000 MOHM
 DIELECTRIC WITHSTANDING VOLTAGE: 500V AC/MN
 CONTACT RESISTANCE: 20 MOHM MAX

STANDARD
 CERTIFIED: E323964 / MODEL NUMBER 612-206

SOLDERING
 REFLOW PROCESS ONLY

PACKAGING
 TAPE & REEL WITH CAP

DIMENSION

NB PIN	A	B	C
10	10.16	18.11	20.30
14	15.24	23.58	25.58
16	17.78	25.70	28.00
20	22.86	31.20	33.20
26	30.48	38.81	40.82
34	40.64	46.34	50.98
40	48.26	56.60	58.60
50	60.96	69.30	71.30

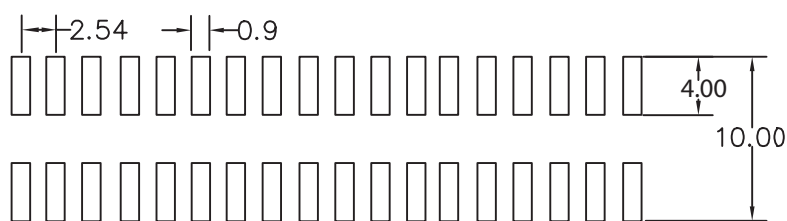
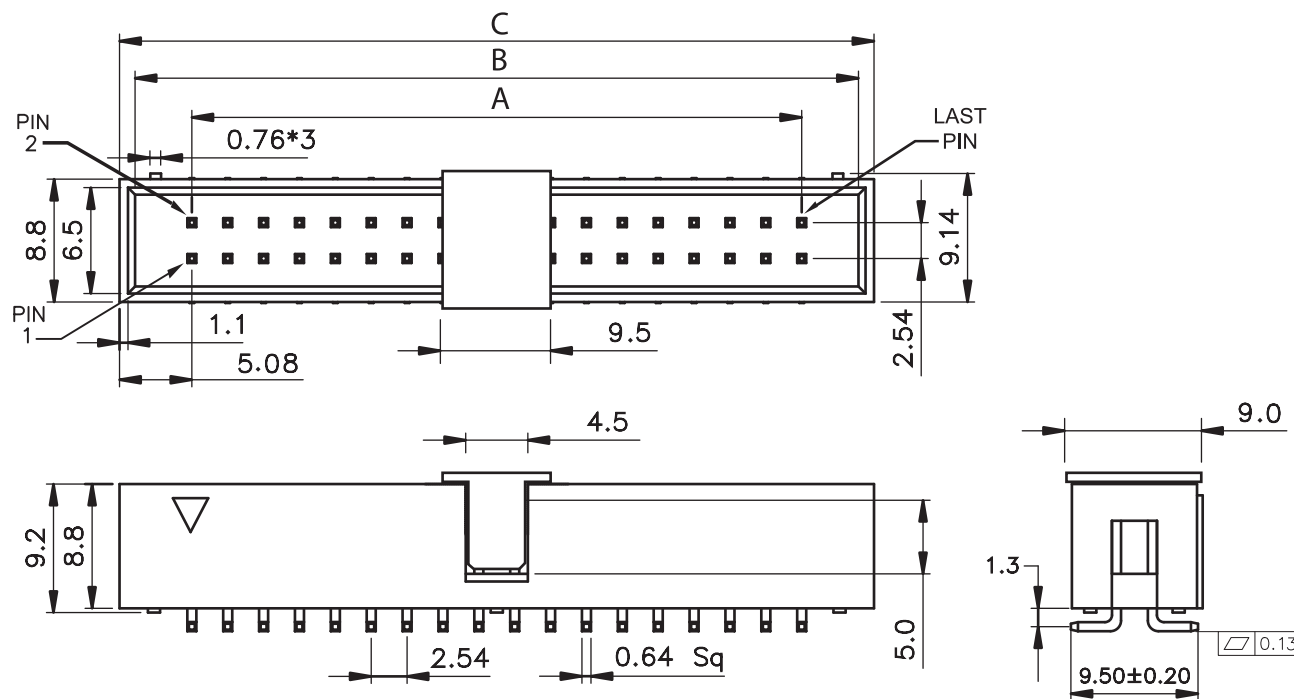

PCB LAYOUT - COMPONENT VIEW

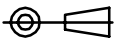
RoHS Compliant				PROJECTION:	GENERAL TOLERANCE		DESCRIPTION: BHD 2.54MM MALE SMT BOX HEADER WERI PART NO: 612 3xx 206 21	SIZE A4
					.X = +/- 0.2 .XX = +/- 0.15			
J	13-JUN-13	DIM 5.08	QL	APPROVAL: RJ	UNIT: MM			
I	22-JUL-11	W DIMENTION	QL		SCALE:			
H	24-MAY-11	NOTE	GG		SHEET: 1/2			
REV	DATE	FILE	BY		DRAW: PEARL			

1

2

3

4

5

NB PIN □	W □
10 □	32 □
14 □	44 □
16 □	44 □
20 □	56 □
26 □	56 □
34 □	72 □
40 □	72 □
50 □	88 □

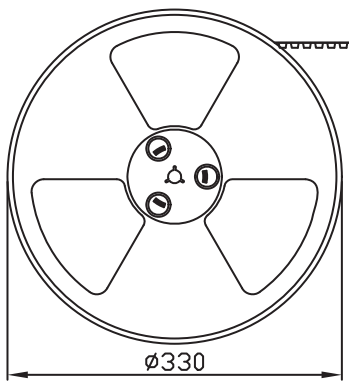
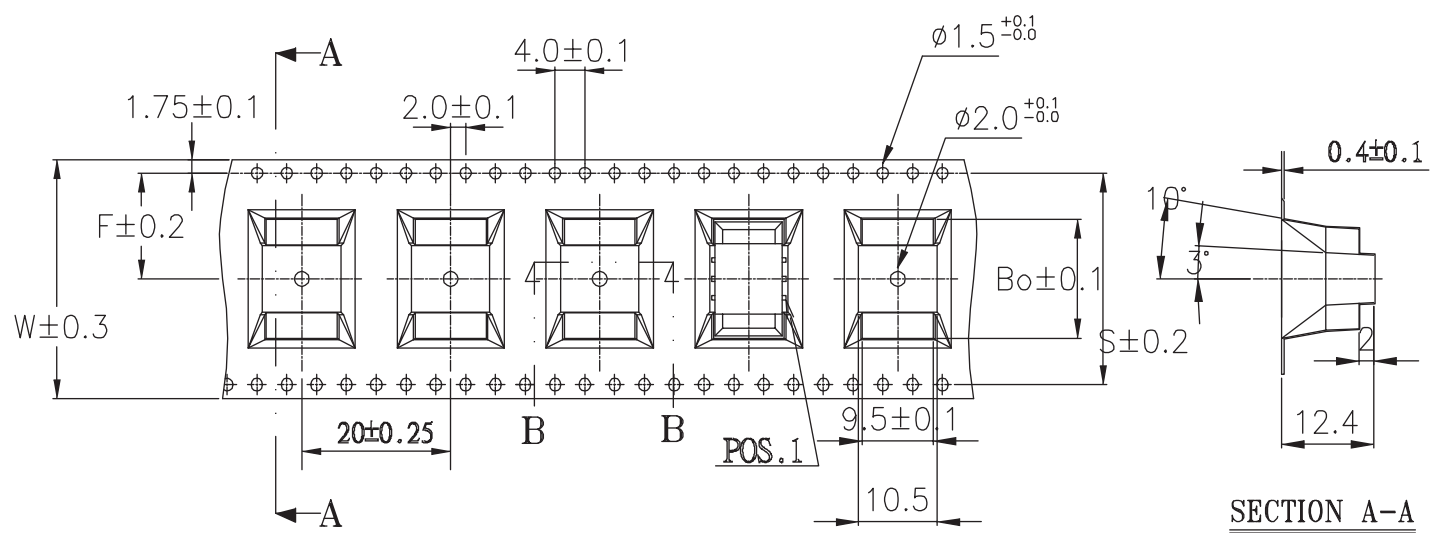

PULL OUT DIRECTION

PULLING OUT DIRECTION

- 1. 10 sprocket hole pitch cumulative tolerance $\pm 0.20\text{mm}$.
- 2. Carrier camber not to exceed 1mm in 100mm.
- 3. All dimensions meet EIA-481-2 requirements.
- 4. Material: Black Anti-Static Polystyrene.
- 5. Component load per 13" reel : 250 pcs. 13"=5.4 M B:8 A:12

NOTE: For the date code before 2011/06/01, the connectors will be positioned on the opposite side of the above drawing

RoHS Compliant				PROJECTION: 	GENERAL TOLERANCE .X = ± 0.2 .XX = ± 0.15		DESCRIPTION: BHD 2.54MM MALE SMT BOX HEADER	SIZE A4
G								
F								
E								
D								
C			APPROVAL: RJ	UNIT: MM	WERI PART NO: 6123 xx 20621			
B				SCALE:				
A				SHEET: 2/2				
REV	DATE	FILE	BY	DRAW: TAYLOR				