

REVISIONS					
REV	ECO	DESCRIPTION	DATE	BY	APPR
A3	-	RELEASE NEW DWG FORMAT	06/07/13	DRP	DRP

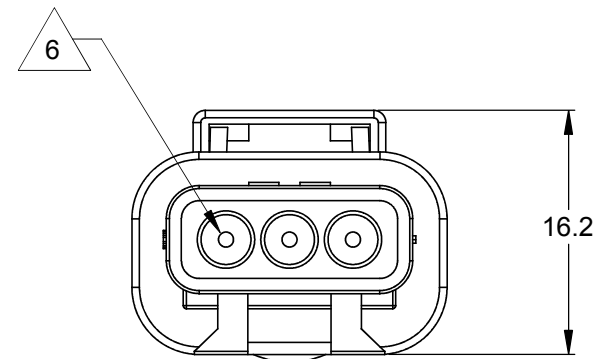

REFER TO PART NUMBER CHART FOR AVAILABLE CONNECTOR COLORS

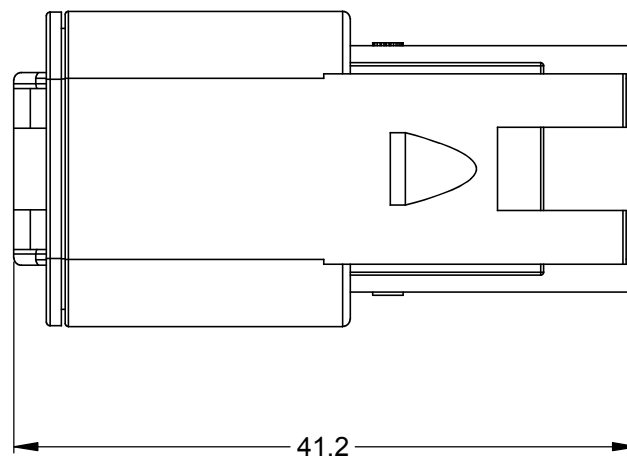
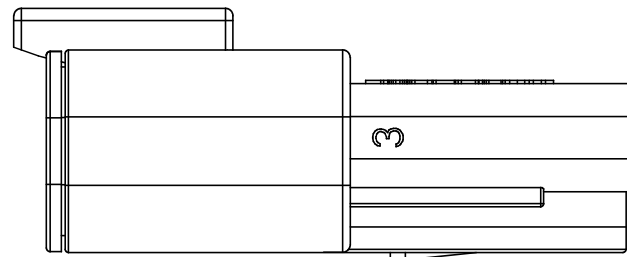
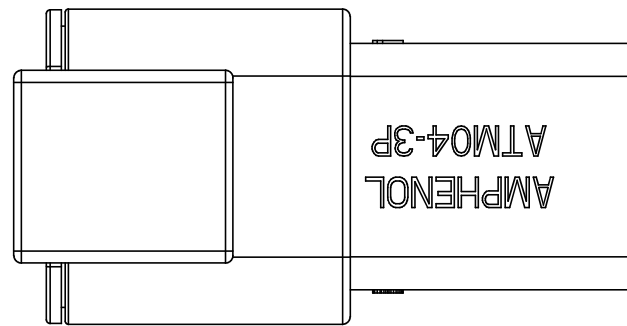
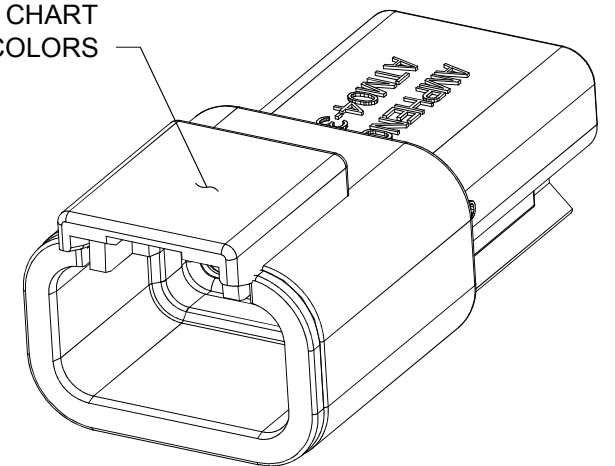

REQUIRES CONTACT RETENTION WEDGE AWM-3P

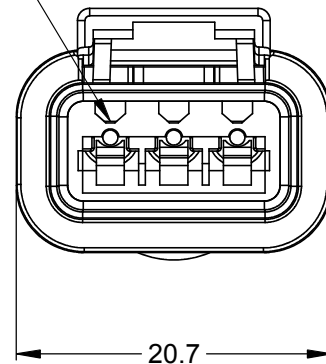

NOTES: UNLESS OTHERWISE SPECIFIED

- MATERIAL:
HOUSING: THERMOPLASTIC
SEAL: SILICONE RUBBER
- MODIFICATIONS: N/A
- SPECIFICATIONS:
 - CURRENT RATING: 7.5 AMPS
 - OPERATING TEMPERATURE: -55°C TO +125°C.
 - DIELECTRIC WITHSTANDING VOLTAGE: LESS THAN 2 MILLIAMPS CURRENT LEAKAGE @ 1500VAC.
 - INSULATION RESISTANCE: 1000MΩ MINIMUM @ 25°C.
 - MOISTURE RESISTANCE: IP67
 - MATING CYCLE DURABILITY: 100 CYCLES
 - RoHS COMPLIANT
- MATING PART: ATM06-3S* PLUG.
(* = MODIFICATIONS AND/OR COLORS)

5. ALL DIMENSIONS ARE FOR REFERENCE USE ONLY.

6 CONTACT SIZE AND WIRE RANGE:

CONTACT SIZE	MIN. INSUL O.D.	MAX. INSUL O.D.	WIRE RANGE
20	1.35 mm (.053 in)	3.05 mm (.120 in)	18 - 22 AWG

PART NUMBER CHART	
COLOR	PART NUMBER
GREY	ATM04-3P
BLACK	ATM04-3P-BLK
BLUE	ATM04-3P-BLU
BROWN	ATM04-3P-BRN
GREEN	ATM04-3P-GRN
RED	ATM04-3P-RED
WHITE	ATM04-3P-WHT
YELLOW	ATM04-3P-YEL

SEE PART NUMBER CHART		DESCRIPTION	ITEM
QUANTITY	PART NUMBER		
<p>UNLESS OTHERWISE SPECIFIED</p> <p>1) All dimensions are in metric(mm).</p> <p>2) Tolerances are as follows:</p> <p>1 PL DEC ±0.30 Fractions ±1/64</p> <p>2 PL DEC ±0.15 Angles ±1°</p> <p>3 PL DEC ±0.08</p> <p>3) Note reference = X</p>			
SIGNATURES		DATE	<p>SINE Systems Corporation</p> <p>A Subsidiary of Amphenol Corporation</p> <p>44724 Morley Drive</p> <p>Clinton Township, MI 48036</p>
DRAWN: D.PARKS		06/07/13	
CHECKED:			
ENGINEER:			
APPROVAL: D.PARKS		06/07/13	<p>RECEPTACLE, 3 PIN, ATM SERIES</p>
CUSTOMER:			
MATERIAL SPECIFICATIONS:		<p>THIS DRAWING IS SUPPLIED FOR INFORMATION ONLY. DESIGN FEATURES, SPECIFICATIONS AND PERFORMANCE DATA SHOWN HEREON ARE THE PROPERTY OF THE AMPHENOL CORPORATION. NO RIGHTS OF REPRODUCTION ARE IMPLIED. ALL DIMENSIONS ARE SUBJECT TO NORMAL MANUFACTURING VARIATIONS.</p>	
PROCESS SPECIFICATIONS:		<p>SIZE: B</p> <p>SCALE: NONE</p>	<p>FSCM NO.:</p> <p>DWG NO.: C- ATM04-3P-XXX</p> <p>REVISION: A3</p>
NEXT ASSY:		SHEET 1 OF 1	

TITLE: RECEPTACLE, 3 PIN, ATM SERIES
DWG NO.: C- ATM04-3P-XXX
REV: A3
SH: 1
OF: 1