

| REV. | DESCRIPTION                    | DATE     | APPROVED |
|------|--------------------------------|----------|----------|
| C    | Engineering Update w/o Changes | 02/16/04 | M. C.    |
|      |                                |          |          |
|      |                                |          |          |
|      |                                |          |          |

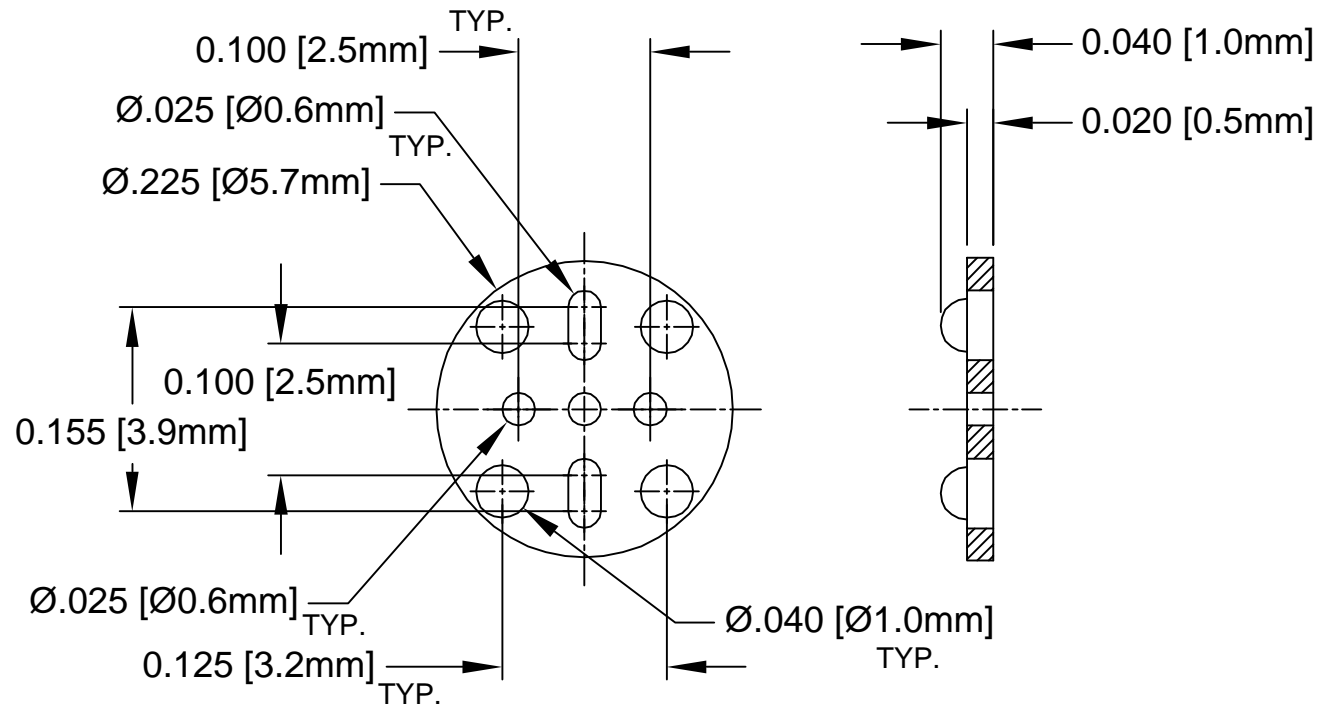

2. MATERIAL: NYLON 6/6, 94V-2, WHITE. BIVAR MATERIAL CODE 04-WE.  
BASF ULTRAMID NYLON 6/6 A3K WHITE.
1. GENERAL SPECIFICATIONS: BIVAR MOLDED COMPONENT SPECIFICATION BV00-E101.

| STANDARD TOLERANCE<br>(UNLESS OTHERWISE SPECIFIED) |         | <b>BIVAR</b> <sup>®</sup>  |                       |
|--|---------|--|-----------------------|
| DECIMALS   | ANGULAR | 4 THOMAS, IRVINE, CA. 92618<br>TEL: (949) 951-8808 FAX: (949) 951-3974 |                       |
| .X ± .1  | X° ± 1° | <b>TITLE:</b> PERM-O-PAD TO-18 MOUNT                                   |                       |
| .XX ± .01  |         | <b>DESIGNED:</b> Shane Irving  | <b>DATE:</b> 06/01/98 |
| .XXX ± .005  |         | <b>CHECKED:</b> M. Chen  | <b>DATE:</b> 06/25/02 |
|  |         | <b>PART NO:</b> 112-040  | <b>REVISION:</b> C    |
|  |         | <b>CAGE CODE :</b> 32559   | <b>SHEET #</b> 1 OF 1 |
| CAD GENERATED DOCUMENT, DO NOT MEASURE DRAWING.    |         |  |                       |