

THIS DRAWING IS UNPUBLISHED
 VERTRAULICHE UNVEROFFENTLICHTE ZEICHNUNG
 © COPYRIGHT 2009 Tyco Electronics AMP GmbH
 RELEASED FOR PUBLICATION
 FREI FUER VEROFFENTLICHUNG
 14.Oct. 2009
 ALL RIGHTS RESERVED.
 ALLE RECHTE VORBEHALTEN.

LOC	DIST	REVISIONS AENDERUNGEN					
AI	-	P	LTR	DESCRIPTION BESCHREIBUNG	DATE	DWN	APVD
PROJEKT NR.:			D1	OUTLINE OF SEALING CHANGED	11DEC2012	KHH	PK

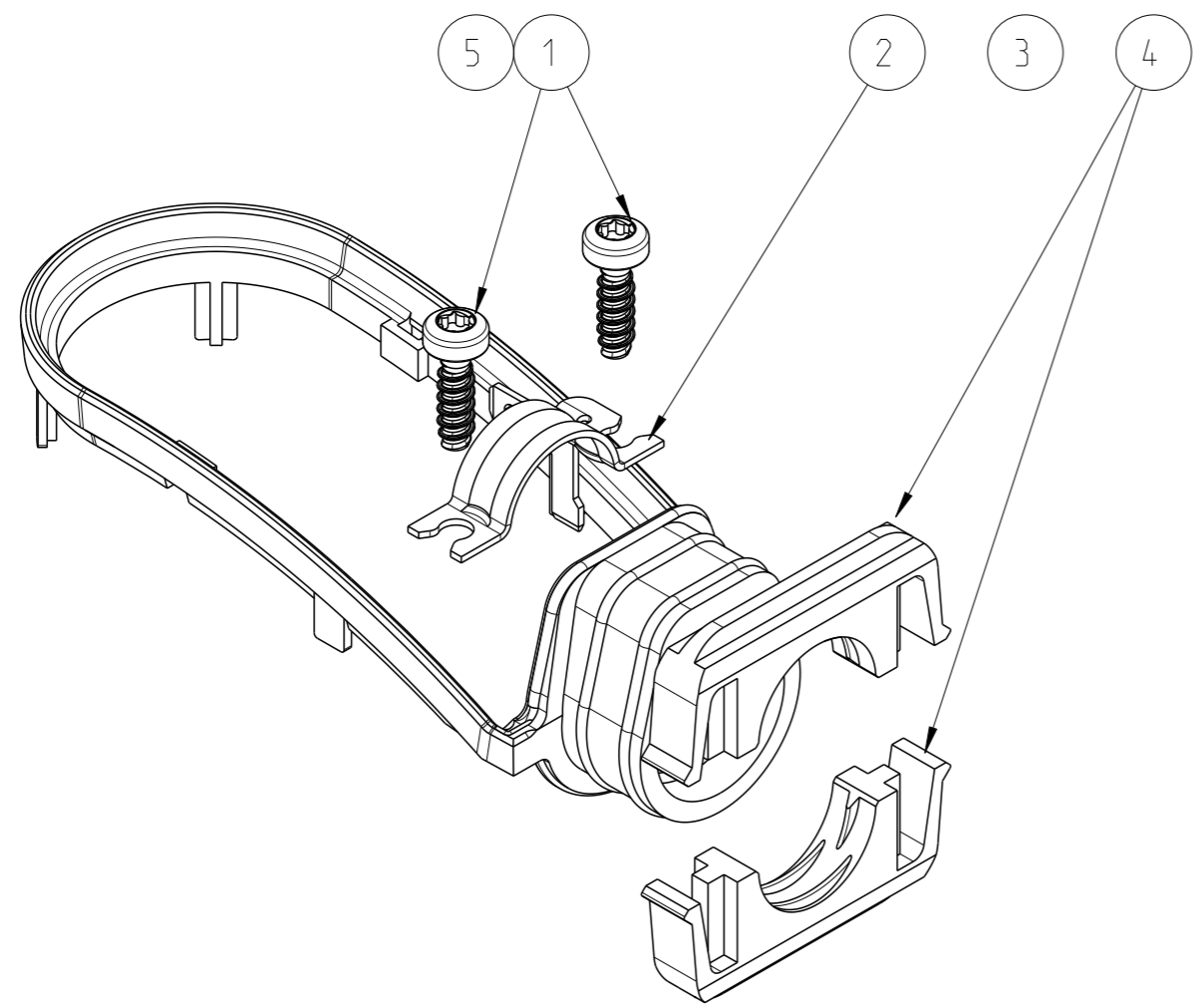

Notes

- 1 SUITABLE HOUSINGS: SERIES HC26
CUSTOMER DRAWING: 1103434, 1103437
- 2 STANDARDS:
DIN EN 61984, DIN EN 60664-1
- 3 PACKAGING PN 0-1 / 0-2:
40 SETS IN A CARTON
- 4 PACKAGING PN 0-3:
1000 PIECES IN A CARTON
- 5 PACKAGING PN 0-4:
500 PIECES IN A CARTON
- 6 PACKAGING PN 0-5:
500 PIECES IN A CARTON
- 7 PACKAGING PN 0-6:
1000 PIECES IN A CARTON
- 8 WIRE SIZE 11.5-12

0-6	0-5	0-4	0-3	0-2	0-1	DESCRIPTION	MATERIAL	COLOR/SURFACE	NOTE	ITEM
-	-	-	-	2	-	SCREW FOR METAL	STEEL	ZINC PLATED	WN5152, 10P2.58	5
-	-	-	1	2	2	STRAIN RELIEF	PBT-GF10	GREY	SERIES HC26. CONN. WIRE SIZE 12MM	4
-	-	1	-	1	1	SEALING	FKM	GREY	SERIES HC26. WIRE SIZE 11.5-12.0	3
-	1	-	-	1	1	SCREEN TERMINATION	COPPER ALLOY	TIN PLATED	SERIES HC26. CONN.HSG	2
1	-	-	-	-	2	SCREW FOR PLASTICS	STEEL	ZINC PLATED	WN5452, 10IP2.5x8	1

PARTS LIST (PER UNIT)

DIESE ZEICHNUNG IST EIN KONTROLLIERTES DOKUMENT. BEMASSUNGEN UND TOLERANZEN GEMAESS GPS (ISO STANDARDS).		TOLERANCING ISO 8015 TOLERIERUNG ISO 8015	
THIS DRAWING IS A CONTROLLED DOCUMENT. DIMENSIONING AND TOLERANCING PER GPS (ISO STANDARDS).		TE Connectivity	
DIMENSIONS: MASSEINHEITEN: MM 			
TOLERANCES UNLESS OTHERWISE SPECIFIED: ALLGEMEINTOLERANZEN 0 PLC ±- 1 PLC ±- 2 PLC ±- 3 PLC ±- 4 PLC ±- ANGLES/WINKEL ±1° FINISH/OBERFLAECHE/FARBE -		NAME ACCESSORY KIT SERIES HC26, ANGLED CONN. HSG. POWER 4 NET	
MATERIAL -		SIZE A3	RESTRICTED TO NUR FUER -
DWN G.WROBLEWSKI 14OCT2009		CAGE CODE 00779	DRAWING NO. ZEICHNUNGS-NR. C=1103519
CHK H.BRAUN 14OCT2009		SCALE MASSSTAB 2:1	SHEET BLATT 1 OF VON 1
APVD T.SCHNURPFIL 14OCT2009		SCALE MASSSTAB 2:1	REV D1
PRODUCT SPEC PRODUKTSPEZ. 108-74097		CUSTOMER DRAWING /KUNDENZEICHNUNG	
APPLICATION SPEC VERARBEITUNGSSPEZ. 114-74103		SCALE MASSSTAB 2:1	