

73 CKT
SCALE 3:2

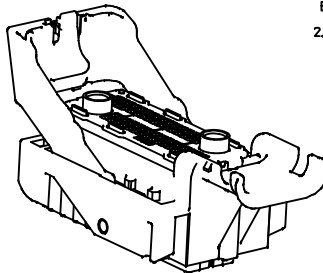

66 CKT
SCALE 3:2

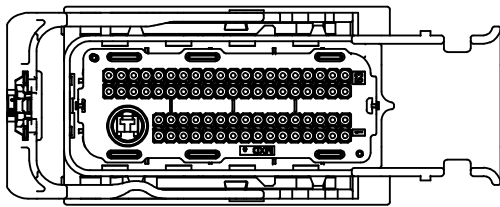
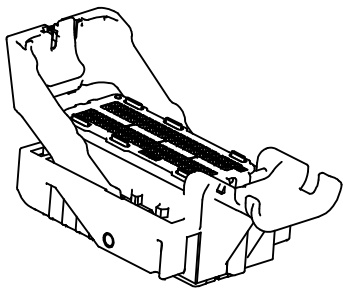
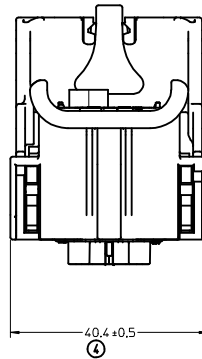
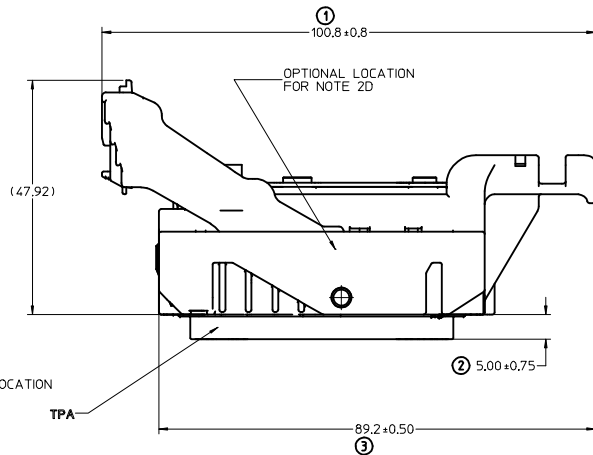
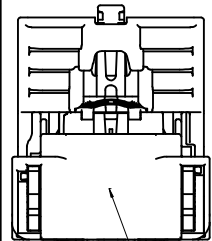

80 CKT
SCALE 3:2

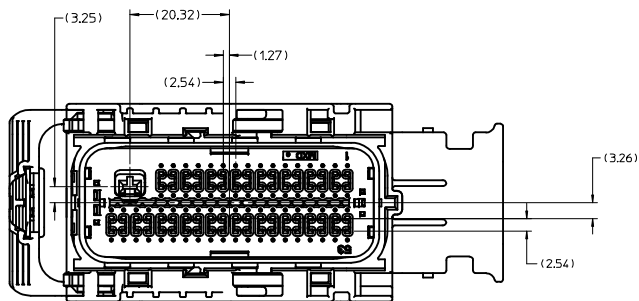

NOTES: UNLESS OTHERWISE SPECIFIED

1. MATERIAL:

- A. RESIN: SEE COMPONENT DRAWINGS
- B. COLOR: SEE TABLE

2. DESIGN - GENERAL:

- A. THIS IS A 100% CAD GENERATED PART. THE CAD MATHEMATICAL DATA IS THE MASTER FOR THIS PART. FOR DIMENSIONAL OR ANY INFORMATION NOT SHOWN ON THIS DRAWING, ANALYZE THE CAD MODEL.
- B. TOLERANCES:
 - a. LINEAR XX ± 0.30
 - XXX ± 0.10
 - XXX ± 0.10
 - b. ANGULAR X° ± 3.0°
- C. CORNERS SHOWN AS SHARP TO BE R 0.2 MAX.
- D. FOLLOWING PRODUCTION CODES TO BE PERMANENTLY MARKED & HUMAN READABLE TO A LETTER HEIGHT < 3mm.
 - LINE #1: MATERIAL #: XXXX-XXXX
 - LINE #2: DATE CODE: JJJ (JULIAN DAY, LAST DIGIT OF YEAR)
 - LINE #3: INSPECTION MACHINE CODE + SERIAL #:X_XXXXX
- E-1. PARTS MUST BE FREE OF DISCOLORATION, SALT RESIDUE AND OTHER IMPERFECTIONS THAT AFFECT FIT OR FUNCTION.
- E-2. SCRATCHES OR DENTS NOT TO EXCEED 0.13mm IN DEPTH.
- F. CHANGES IN DESIGN FROM PART PREVIOUSLY APPROVED REQUIRES PRIOR ENGINEERING APPROVAL. THIS INCLUDES BUT IS NOT LIMITED TO DRAFT, MATERIAL OR PROCESSING.
- G. SHALL CONFORM TO THE FOLLOWING PACKAGING SPECIFICATION: PK-31300-019

3. DESIGN - MANUFACTURING:

- A. DRAFT TO BE WITHIN TOLERANCE.
- B. ALLOWABLE FLASH 0.2 MAX HIGH X 0.13 MAX THICK.
- C. ALLOWABLE PARTING LINE MISMATCH 0.2 MAX.
- D. EJECTOR PINS MARK TO BE FLUSH TO 0.25 MAX DEPRESSED.
- E. ALLOWABLE GATE VESTIGE TO BE FLUSH TO 0.25 MAX PROTRUSION.

4. SYSTEM REQUIREMENTS:

- WHEN TESTED TO SAE/USCAR-2 REV: 3, APRIL 2001, AND GMW #3191, AUGUST 22, 2000 (DRAFT).
- A. TPA (WITHOUT TERMINALS)
 - a. INSERTION FORCE FROM PRE-SET TO LOCK: ≥20
 - b. REMOVAL FORCE FROM PRE-SET: ≥20
- B. CPA
 - a. INSERTION FORCE FROM PRE-SET TO LOCK WITH CONNECTOR UN-MATED: ≥60N
 - b. REMOVAL FORCE FROM PRE-SET: ≥30N
- C. GROMMET CAP
 - a. REMOVAL FORCE FROM HOUSING WITH ENGAGED LATCHES: ≥110N
- D. MATE ASSIST LEVER
 - a. INADVERTENT ACTUATION FORCE DURING SHIPPING, HANDLING OR PRE-ASSEMBLY: ≥190N

REV	DESCRIPTION
G6	66CKT KEY C OPT 9 ACTIVE
G5	ADDED PART NUMBERS 34566-6173 34566-6183 34566-6193
G4	ADDED PART NUMBERS 34566-6093 34566-6110 34566-6123 34566-6133
G3	ADDED PART NUMBERS 34566-6083
G2	ADDED PART NUMBERS 34566-6053 34566-6063 34566-6073
G1	ADDED PART NUMBERS 34566-6023 34566-6033 34566-6043
G	ADDED PART NUMBERS 34566-5923 34566-6013
F99	ADDED PART NUMBERS 34566-5983
F98	ADDED PART NUMBERS 34566-5943 34566-5953 34566-5963 34566-5973
F97	ADDED PART NUMBERS 34566-5933
F96	ADDED PART NUMBERS 34566-5863 34566-5873 34566-5883 34566-5893 34566-5913
F95	ADDED PART NUMBERS 34566-5853
F94	ADDED PART NUMBERS 34566-5843
F93	ADDED PART NUMBERS 34566-5733 34566-5743 34566-5753 34566-5763 34566-5773 34566-5783 34566-5793 34566-5813 34566-5823 34566-5833
F92	ADDED PART NUMBERS 34566-5313 34566-5433 34566-5443 34566-5453 34566-5463 34566-5473 34566-5483 34566-5493 34566-5513 34566-5523 34566-5533 34566-5543 34566-5553 34566-5563 34566-5573 34566-5583 34566-5593 34566-5613 34566-5623 34566-5633 34566-5643 34566-5653 34566-5663 34566-5673 34566-5683 34566-5693 34566-5713
F91	ADDED PART NUMBERS 34566-5353 34566-5363 34566-5373 34566-5383 34566-5393 34566-5413
F90	ADDED PART NUMBERS 34566-5343
F89	ADDED PART NUMBERS 34566-5223 34566-5333
F88	ADDED PART NUMBERS 34566-5283 34566-5293
F87	ADDED PART NUMBERS 34566-5263 34566-5273
F86	ADDED PART NUMBERS 34566-5243 34566-5253
F85	ADDED PART NUMBERS 34566-5193 34566-5213 34566-5223 34566-5233
F84	ADDED PART NUMBERS 34566-5183
F83	ADDED PART NUMBERS 34566-5163 34566-5173
F82	ADDED PART NUMBERS 34566-5063 34566-5073 34566-5083 34566-5093 34566-5113 34566-5123 34566-5133 34566-5143 34566-5153
F81	ADDED PART NUMBERS 34566-5023 34566-5033 34566-5043 34566-5053

ENTER DESCRIPTION IEC NO: UAU2014-0574 DRAWN BY: SKRAJENDRANA CHKD: SKRAJENDRANA APPR: IKOSHY 2013/10/09	QUALITY SYMBOLS ∇=0 ∇=0 ∇=0	GENERAL TOLERANCES (UNLESS SPECIFIED): mm INCH 4 PLACES +---+---+---+--- 3 PLACES +---+---+---+--- 2 PLACES +---+---+---+--- 1 PLACE +---+---+---+--- 0 PLACE +---+---+---+--- ANGULAR ±---° DRAFT WHERE APPLICABLE MUST REMAIN WITHIN DIMENSIONS	DIMENSION STYLE MM ONLY DRAWN BY: SKRAJENDRANA CHECKED BY: MYANS LAMBROU APPROVED BY:	SCALE: 2:1 DESIGN UNITS: METRIC THIRD ANGLE PROJECTION	MX123 66/73/80CKT HRNS CONN ASSY molex	MATERIAL NO: SEE BOM TABLE DOCUMENT NO: SD-34566-001	SHEET NO: 1 OF 68

80 CKT

WIRE DRESS OPTION 0

HOUSING ONLY, SHOWN FOR CLARITY

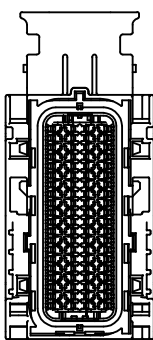
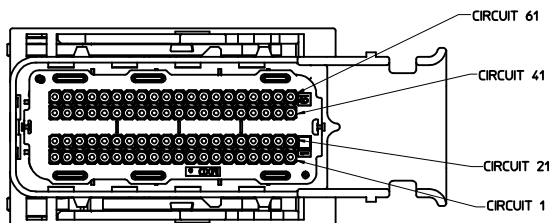

KEY G

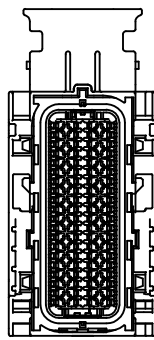

KEY H

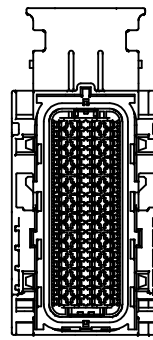

KEY J

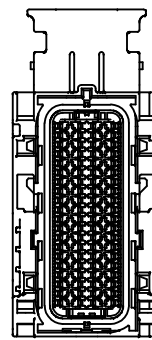

KEY K

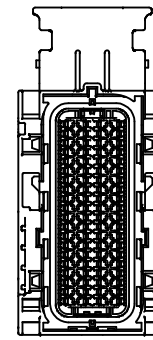

KEY L

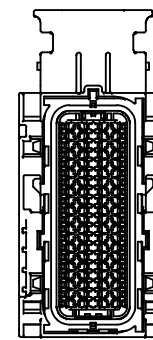

KEY M

WIRE DRESS OPTION 9

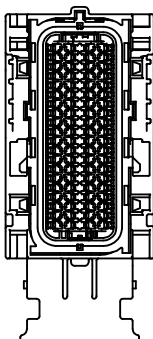
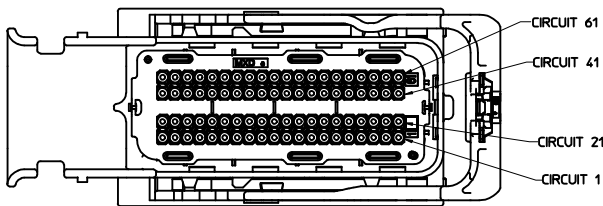

KEY G

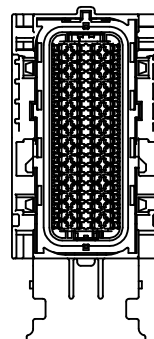

KEY H

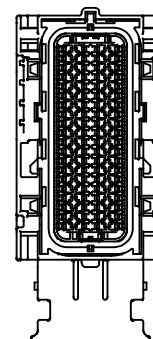

KEY J

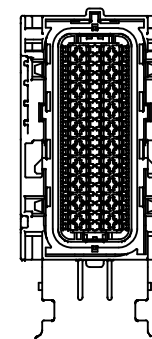

KEY K

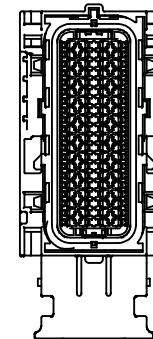

KEY L

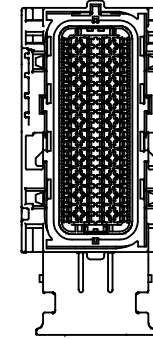

KEY M

ENTER DESCRIPTION EC NO: UAU2014-0574 DRAWN BY: SKRAJENDRANA 2011/02/14 CHKD: SKRAJENDRANA 2013/10/08 APPR: WOSHY REV: G0	QUALITY SYMBOLS ▽=0 ▽=0 ▽=0	GENERAL TOLERANCES (UNLESS SPECIFIED) mm INCH 4 PLACES +--- +--- 3 PLACES +--- +--- 2 PLACES +--- +--- 1 PLACE +--- +--- 0 PLACE +--- +--- ANGULAR ±---° DRAFT WHERE APPLICABLE MUST REMAIN WITHIN DIMENSIONS	DIMENSION STYLE MM ONLY DRAWN BY: SKRAJENDRANA 2011/02/14 CHECKED BY: MYANSLAMBROU 2011/02/14 APPROVED BY:	SCALE 1.5:1 DESIGN UNITS METRIC THIRD ANGLE PROJECTION	TITLE MX123 66/73/80CKT HRNS CONN ASSY molex	MATERIAL NO. SEE BOM TABLE SIZE D	DOCUMENT NO. SD-34566-001	SHEET NO. 2 OF 68
	THIS DRAWING CONTAINS INFORMATION THAT IS PROPRIETARY TO MOLEX INCORPORATED AND SHOULD NOT BE USED WITHOUT WRITTEN PERMISSION							
	THIS DRAWING CONTAINS INFORMATION THAT IS PROPRIETARY TO MOLEX INCORPORATED AND SHOULD NOT BE USED WITHOUT WRITTEN PERMISSION							
	THIS DRAWING CONTAINS INFORMATION THAT IS PROPRIETARY TO MOLEX INCORPORATED AND SHOULD NOT BE USED WITHOUT WRITTEN PERMISSION							

73 CKT

WIRE DRESS OPTION 0

HOUSING ONLY, SHOWN FOR CLARITY

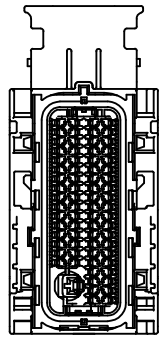
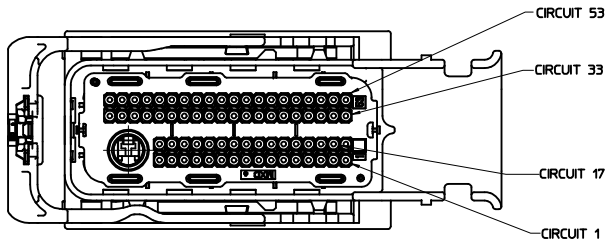

KEY A

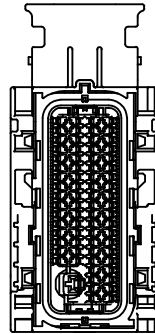

KEY B

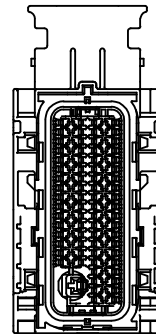

KEY O

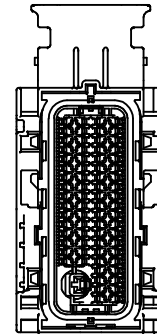

KEY D

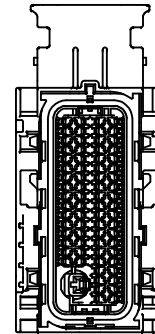

KEY E

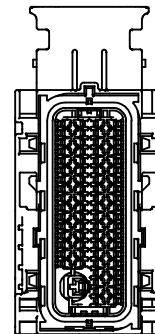

KEY F

WIRE DRESS OPTION 9

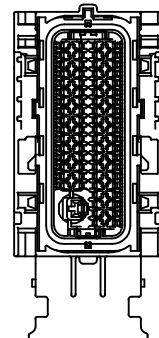
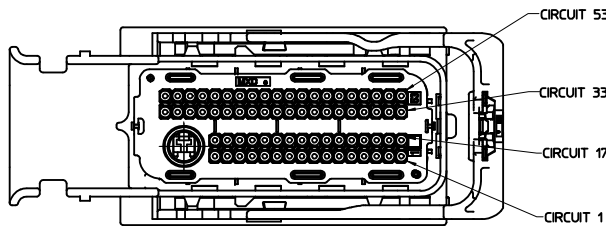

KEY A

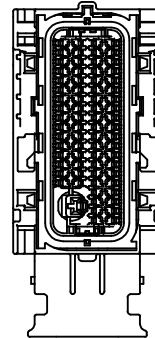

KEY B

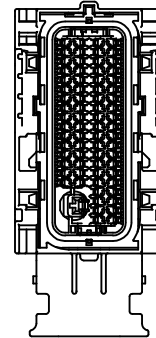

KEY O

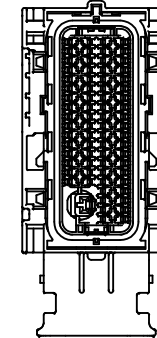

KEY D

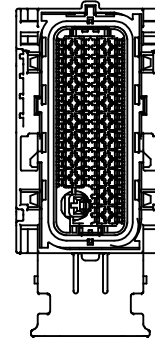

KEY E

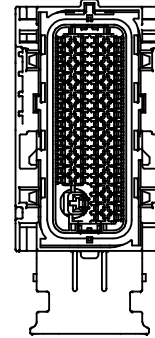

KEY F

ENTER DESCRIPTION IEC NO: UAU2014-0574 DRAWN BY: SKRAJENDRANA 2013/10/08 CHKD: APPR: VKOSHY 2013/10/09 REV:	QUALITY SYMBOLS	GENERAL TOLERANCES (UNLESS SPECIFIED)		DIMENSION STYLE	SCALE	DESIGN UNITS	THIRD ANGLE PROJECTION
	▽=0	mm	INCH	MM ONLY	1.5:1	METRIC	
	▽=0	4 PLACES	+	SKRAJENDRANA 2011/02/14	DATE	TITLE	
	▽=0	3 PLACES	+	MYANSLAMBROU 2011/02/14	DATE		
		ANGULAR ±		APPROVED BY	DATE		
		DRAFT WHERE APPLICABLE MUST REMAIN WITHIN DIMENSIONS		MATERIAL NO.	DOCUMENT NO.		
				SEE BOM TABLE	SD-34566-001		
				THIS DRAWING CONTAINS INFORMATION THAT IS PROPRIETARY TO MOLEX INCORPORATED AND SHOULD NOT BE USED WITHOUT WRITTEN PERMISSION			

MX123
66/73/80CKT
HRNS CONN ASSY

molex

SHEET NO.
3 OF 68

66 CKT

WIRE DRESS OPTION 0

HOUSING ONLY, SHOWN FOR CLARITY

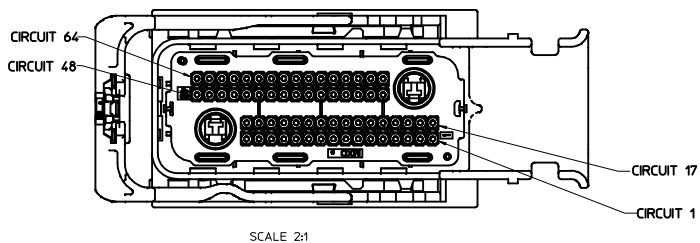

SCALE 2:1

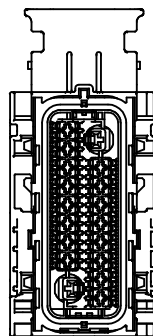

KEY A

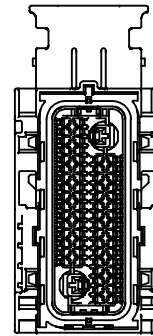

KEY C

WIRE DRESS OPTION 9

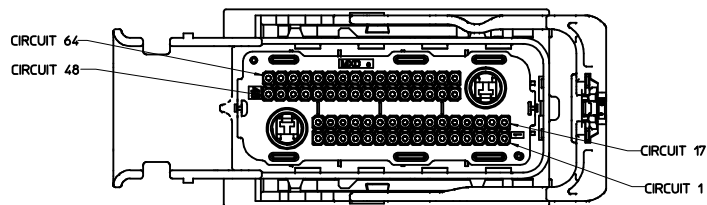

SCALE 2:1

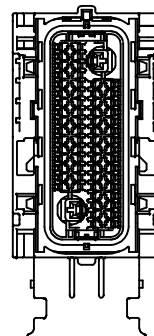

KEY A

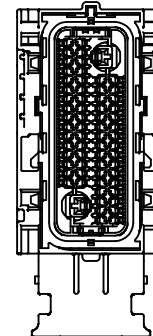

KEY C

ENTER DESCRIPTION DEC NO: UAU2014-0574 DRAWN: SKRAJENDRANA 2013/10/08 CHKD: APPR: VIOSHY 2013/10/09 REV: G0	QUALITY SYMBOLS ▽=0 ▽=0 ▽=0	GENERAL TOLERANCES (UNLESS SPECIFIED) <table border="1"> <thead> <tr> <th></th> <th>mm</th> <th>INCH</th> </tr> </thead> <tbody> <tr> <td>4 PLACES</td> <td>± ---</td> <td>± ---</td> </tr> <tr> <td>3 PLACES</td> <td>± ---</td> <td>± ---</td> </tr> <tr> <td>2 PLACES</td> <td>± ---</td> <td>± ---</td> </tr> <tr> <td>1 PLACE</td> <td>± ---</td> <td>± ---</td> </tr> <tr> <td>0 PLACE</td> <td>± ---</td> <td>± ---</td> </tr> </tbody> </table> ANGULAR ± ---° DRAFT WHERE APPLICABLE MUST REMAIN WITHIN DIMENSIONS		mm	INCH	4 PLACES	± ---	± ---	3 PLACES	± ---	± ---	2 PLACES	± ---	± ---	1 PLACE	± ---	± ---	0 PLACE	± ---	± ---	DIMENSION STYLE MM ONLY DRAWN BY: SKRAJENDRANA 2011/02/14 CHECKED BY: MYANSLAMBROU 2011/02/14 APPROVED BY:	SCALE 1.5:1 DESIGN UNITS METRIC THIRD ANGLE PROJECTION	TITLE MX123 66/73/80CKT HRNS CONN ASSY molex	MATERIAL NO. SEE BOM TABLE DOCUMENT NO. SD-34566-001 SHEET NO. 4 OF 68
		mm	INCH																					
4 PLACES	± ---	± ---																						
3 PLACES	± ---	± ---																						
2 PLACES	± ---	± ---																						
1 PLACE	± ---	± ---																						
0 PLACE	± ---	± ---																						
THIS DRAWING CONTAINS INFORMATION THAT IS PROPRIETARY TO MOLEX INCORPORATED AND SHOULD NOT BE USED WITHOUT WRITTEN PERMISSION																								

STATUS	GM PART #	MATERIAL #	PART/MATERIAL REVISION	WIRE DRESS OPTION	KEY OPTION	COLOR (TPA)	NUMBERS INDICATE CAVITIES OPEN FOR CIRCUITS
AVAILABLE	12582677	34566-0103	G	0	A	BLACK	
AVAILABLE	12582678	34566-0203	G	0	B	ST GRY	72 71 70 69 68 67 66 65 64 63 62 61 60 59 58 57 56 55 54 53
AVAILABLE	12615654	34566-0303	G	0	C	BLUE	52 51 50 49 48 47 46 45 44 43 42 41 40 39 38 37 36 35 34 33
ACTIVE	12615660	34566-0403	G	0	D	BROWN	73 32 31 30 29 28 27 26 25 24 23 22 21 20 19 18 17
ACTIVE	12615661	34566-0503	G	0	E	GREEN	16 15 14 13 12 11 10 9 8 7 6 5 4 3 2 1
ACTIVE	12615662	34566-0603	G	0	F	NATURAL	
AVAILABLE	12588057	34566-0703	G	0	G	BLUE	
AVAILABLE	12588058	34566-0803	G	0	H	ST GRY	80 79 78 77 76 75 74 73 72 71 70 69 68 67 66 65 64 63 62 61
ACTIVE	12615658	34566-0903	G	0	J	BLACK	60 59 58 57 56 55 54 53 52 51 50 49 48 47 46 45 44 43 42 41
ACTIVE	TBD	34566-1003	G	0	K	BROWN	40 39 38 37 36 35 34 33 32 31 30 29 28 27 26 25 24 23 22 21
ACTIVE	TBD	34566-1103	G	0	L	GREEN	20 19 18 17 16 15 14 13 12 11 10 9 8 7 6 5 4 3 2 1
ACTIVE	TBD	34566-1203	G	0	M	NATURAL	
AVAILABLE	12603596	34566-1303	G	9	A	BLACK	
AVAILABLE	12603597	34566-1403	G	9	B	ST GRY	72 71 70 69 68 67 66 65 64 63 62 61 60 59 58 57 56 55 54 53
AVAILABLE	12615655	34566-1503	G	9	C	BLUE	52 51 50 49 48 47 46 45 44 43 42 41 40 39 38 37 36 35 34 33
ACTIVE	12615663	34566-1603	G	9	D	BROWN	73 32 31 30 29 28 27 26 25 24 23 22 21 20 19 18 17
ACTIVE	12615664	34566-1703	G	9	E	GREEN	16 15 14 13 12 11 10 9 8 7 6 5 4 3 2 1
ACTIVE	12615665	34566-1803	G	9	F	NATURAL	
AVAILABLE	12603598	34566-1903	G	9	G	BLUE	
AVAILABLE	12603599	34566-2003	G	9	H	ST GRY	80 79 78 77 76 75 74 73 72 71 70 69 68 67 66 65 64 63 62 61
ACTIVE	12615659	34566-2103	G	9	J	BLACK	60 59 58 57 56 55 54 53 52 51 50 49 48 47 46 45 44 43 42 41
ACTIVE	TBD	34566-2203	G	9	K	BROWN	40 39 38 37 36 35 34 33 32 31 30 29 28 27 26 25 24 23 22 21
ACTIVE	TBD	34566-2303	G	9	L	GREEN	20 19 18 17 16 15 14 13 12 11 10 9 8 7 6 5 4 3 2 1
ACTIVE	TBD	34566-2403	G	9	M	NATURAL	
AVAILABLE	TBD	34822-0013	A	0	A	BLACK	64 63 62 61 60 59 58 57 56 55 54 53 52 51 50 49 48 47 46 45 44 43 42 41 40 39 38 37 36 35 34 33 66
AVAILABLE	TBD	34822-0033	A	0	C	BLUE	65 32 31 30 29 28 27 26 25 24 23 22 21 20 19 18 17 16 15 14 13 12 11 10 9 8 7 6 5 4 3 2 1
AVAILABLE	TBD	34822-0023	A	9	A	BLACK	64 63 62 61 60 59 58 57 56 55 54 53 52 51 50 49 48 47 46 45 44 43 42 41 40 39 38 37 36 35 34 33 66
ACTIVE	TBD	34822-0043	A	9	C	BLUE	65 32 31 30 29 28 27 26 25 24 23 22 21 20 19 18 17 16 15 14 13 12 11 10 9 8 7 6 5 4 3 2 1
N/A	N/A	N/A	N/A	N/A	N/A	N/A	73
AVAILABLE	NOT APPLICABLE	34566-2503	G	0	A	BLACK	72 71 69 68 67 66 64 63 62 59 56 53 52 51 50 49 48 47 46 45 44 43 42 39 36 35 33 73 32 30 29 27 23 20 17 14 13 12 11 9 8 5 4 3 2 1

SEE NEXT PAGE FOR ADDITIONAL NUMBERS

ENTER DESCRIPTION EC NO: UAU2014-0574 DRAWN BY: SKRAJENDRANA 2013/10/08 CHKD: CHD APPR: IKOSHY 2013/10/09 REV: GO	QUALITY SYMBOLS ∇=0 ∇=0 ∇=0	GENERAL TOLERANCES (UNLESS SPECIFIED) DIMENSION STYLE MM ONLY	SCALE DESIGN UNITS METRIC	THIRD ANGLE PROJECTION	
	4 PLACES +---+---+ 3 PLACES +---+---+ 2 PLACES +---+---+ 1 PLACE +---+---+ 0 PLACE +---+---+	DIMENSION STYLE MM ONLY	SCALE DESIGN UNITS METRIC	THIRD ANGLE PROJECTION	DRAWN BY: SKRAJENDRANA 2011/02/14 DATE: 2011/02/14 CHECKED BY: MYANSLAMBROU 2011/02/14 DATE: 2011/02/14 APPROVED BY:
	ANGULAR ±---° DRAFT WHERE APPLICABLE MUST REMAIN WITHIN DIMENSIONS	MATERIAL NO. SEE BOM TABLE	DOCUMENT NO. SD-34566-001	SHEET NO. 5 OF 68	TITLE MX123 66/73/80CKT HRNS CONN ASSY molex
	THIS DRAWING CONTAINS INFORMATION THAT IS PROPRIETARY TO MOLEX INCORPORATED AND SHOULD NOT BE USED WITHOUT WRITTEN PERMISSION				

STATUS	GM PART #	MATERIAL #	PART/ MATERIAL REVISION	WIRE DRESS OPTION	KEY OPTION ▽	COLOR (TPA) ▽	NUMBERS INDICATE CAVITIES OPEN FOR CIRCUITS ▽																																																																																
AVAILABLE	NOT APPLICABLE	34566-3603	G	0	B	ST GRV	<table border="1"> <tr><td></td><td></td><td></td><td></td><td>68</td><td></td><td></td><td></td><td>64</td><td></td><td></td><td></td><td></td><td></td><td>59</td><td>57</td><td>55</td><td>53</td></tr> <tr><td></td><td></td><td>49</td><td>48</td><td>46</td><td></td><td></td><td></td><td></td><td></td><td></td><td></td><td></td><td></td><td>39</td><td>37</td><td>35</td><td>33</td></tr> <tr><td>73</td><td></td><td>32</td><td></td><td>29</td><td></td><td></td><td></td><td></td><td></td><td></td><td></td><td></td><td></td><td>23</td><td>21</td><td></td><td>18</td></tr> <tr><td></td><td></td><td></td><td></td><td></td><td></td><td></td><td></td><td>11</td><td>10</td><td></td><td></td><td></td><td></td><td>7</td><td></td><td></td><td></td></tr> </table>					68				64						59	57	55	53			49	48	46										39	37	35	33	73		32		29										23	21		18									11	10					7											
				68				64						59	57	55	53																																																																						
		49	48	46										39	37	35	33																																																																						
73		32		29										23	21		18																																																																						
								11	10					7																																																																									
AVAILABLE	NOT APPLICABLE	34566-3703	G	0	A	BLACK	<table border="1"> <tr><td></td><td></td><td></td><td></td><td>68</td><td>67</td><td>66</td><td>65</td><td></td><td></td><td></td><td></td><td></td><td></td><td>59</td><td></td><td>55</td><td>53</td></tr> <tr><td></td><td></td><td>49</td><td>48</td><td>47</td><td></td><td></td><td>44</td><td></td><td></td><td></td><td></td><td></td><td></td><td>39</td><td></td><td>35</td><td>33</td></tr> <tr><td>73</td><td></td><td></td><td></td><td></td><td></td><td></td><td>29</td><td>28</td><td></td><td></td><td></td><td></td><td></td><td>23</td><td></td><td></td><td></td></tr> <tr><td></td><td></td><td></td><td></td><td></td><td></td><td></td><td></td><td></td><td></td><td></td><td></td><td></td><td></td><td>7</td><td></td><td></td><td></td></tr> </table>					68	67	66	65							59		55	53			49	48	47			44							39		35	33	73							29	28						23																		7											
				68	67	66	65							59		55	53																																																																						
		49	48	47			44							39		35	33																																																																						
73							29	28						23																																																																									
														7																																																																									
AVAILABLE	NOT APPLICABLE	34566-3803	G	0	A	BLACK	<table border="1"> <tr><td>72</td><td>71</td><td></td><td>69</td><td>68</td><td>67</td><td>66</td><td></td><td>64</td><td>63</td><td>62</td><td></td><td></td><td></td><td>59</td><td></td><td>56</td><td>53</td></tr> <tr><td></td><td></td><td>50</td><td></td><td>48</td><td>46</td><td>44</td><td>43</td><td>42</td><td></td><td></td><td></td><td></td><td></td><td>39</td><td></td><td>36</td><td>33</td></tr> <tr><td></td><td></td><td></td><td></td><td>32</td><td></td><td>30</td><td>29</td><td>27</td><td></td><td></td><td></td><td></td><td></td><td>23</td><td></td><td>20</td><td>17</td></tr> <tr><td>73</td><td></td><td></td><td></td><td></td><td></td><td>14</td><td>13</td><td>12</td><td>11</td><td>10</td><td>9</td><td>8</td><td></td><td></td><td>5</td><td>4</td><td>3</td><td>2</td><td>1</td></tr> </table>	72	71		69	68	67	66		64	63	62				59		56	53			50		48	46	44	43	42						39		36	33					32		30	29	27						23		20	17	73						14	13	12	11	10	9	8			5	4	3	2	1						
72	71		69	68	67	66		64	63	62				59		56	53																																																																						
		50		48	46	44	43	42						39		36	33																																																																						
				32		30	29	27						23		20	17																																																																						
73						14	13	12	11	10	9	8			5	4	3	2	1																																																																				
AVAILABLE	NOT APPLICABLE	34566-3903	G	0	B	ST GRV	<table border="1"> <tr><td></td><td></td><td></td><td></td><td></td><td></td><td></td><td></td><td>65</td><td></td><td></td><td></td><td></td><td></td><td>59</td><td>57</td><td>55</td><td>53</td></tr> <tr><td></td><td></td><td>49</td><td>48</td><td></td><td></td><td></td><td></td><td>44</td><td></td><td></td><td></td><td></td><td></td><td>39</td><td>37</td><td>35</td><td>33</td></tr> <tr><td>73</td><td></td><td></td><td></td><td></td><td></td><td></td><td></td><td>29</td><td>28</td><td></td><td></td><td></td><td></td><td>24</td><td>23</td><td>21</td><td></td></tr> <tr><td></td><td></td><td></td><td></td><td></td><td></td><td></td><td></td><td></td><td></td><td></td><td></td><td></td><td></td><td>7</td><td></td><td></td><td></td></tr> </table>									65						59	57	55	53			49	48					44						39	37	35	33	73								29	28					24	23	21																7											
								65						59	57	55	53																																																																						
		49	48					44						39	37	35	33																																																																						
73								29	28					24	23	21																																																																							
														7																																																																									
AVAILABLE	NOT APPLICABLE	34566-4003	G	0	B	ST GRV	<table border="1"> <tr><td></td><td></td><td></td><td></td><td></td><td>67</td><td>66</td><td></td><td>64</td><td>63</td><td></td><td></td><td></td><td></td><td>59</td><td>57</td><td>55</td><td>53</td></tr> <tr><td></td><td>50</td><td>49</td><td>48</td><td></td><td></td><td></td><td></td><td>43</td><td></td><td></td><td></td><td></td><td></td><td>39</td><td>37</td><td>35</td><td>33</td></tr> <tr><td>73</td><td></td><td></td><td>32</td><td></td><td></td><td></td><td></td><td>29</td><td>27</td><td></td><td></td><td></td><td></td><td>24</td><td>23</td><td>21</td><td>18</td></tr> <tr><td></td><td></td><td></td><td></td><td>15</td><td></td><td></td><td></td><td></td><td></td><td></td><td></td><td></td><td></td><td>7</td><td>6</td><td>5</td><td>4</td><td>3</td><td></td></tr> </table>						67	66		64	63					59	57	55	53		50	49	48					43						39	37	35	33	73			32					29	27					24	23	21	18					15										7	6	5	4	3							
					67	66		64	63					59	57	55	53																																																																						
	50	49	48					43						39	37	35	33																																																																						
73			32					29	27					24	23	21	18																																																																						
				15										7	6	5	4	3																																																																					
AVAILABLE	NOT APPLICABLE	34566-4103	G	0	A	BLACK	<table border="1"> <tr><td>72</td><td>71</td><td></td><td>69</td><td>68</td><td>67</td><td>66</td><td></td><td>64</td><td>63</td><td>62</td><td></td><td></td><td></td><td>60</td><td>59</td><td></td><td></td><td></td><td></td></tr> <tr><td>52</td><td></td><td>49</td><td>48</td><td>46</td><td>45</td><td>44</td><td>43</td><td>42</td><td></td><td></td><td></td><td></td><td></td><td>40</td><td>39</td><td></td><td></td><td>35</td><td>33</td></tr> <tr><td></td><td></td><td></td><td>32</td><td></td><td></td><td></td><td></td><td>29</td><td>27</td><td>26</td><td></td><td></td><td></td><td>24</td><td>23</td><td></td><td></td><td>17</td><td></td></tr> <tr><td>73</td><td></td><td></td><td></td><td></td><td></td><td>14</td><td>13</td><td>12</td><td>11</td><td>10</td><td>9</td><td>8</td><td>7</td><td>6</td><td>5</td><td>4</td><td>3</td><td>2</td><td>1</td></tr> </table>	72	71		69	68	67	66		64	63	62				60	59					52		49	48	46	45	44	43	42						40	39			35	33				32					29	27	26				24	23			17		73						14	13	12	11	10	9	8	7	6	5	4	3	2	1
72	71		69	68	67	66		64	63	62				60	59																																																																								
52		49	48	46	45	44	43	42						40	39			35	33																																																																				
			32					29	27	26				24	23			17																																																																					
73						14	13	12	11	10	9	8	7	6	5	4	3	2	1																																																																				
AVAILABLE	NOT APPLICABLE	34566-4203	G	0	B	ST GRV	<table border="1"> <tr><td></td><td></td><td></td><td></td><td></td><td></td><td></td><td></td><td></td><td></td><td></td><td></td><td></td><td></td><td>59</td><td>57</td><td>55</td><td>53</td></tr> <tr><td></td><td>50</td><td>49</td><td>48</td><td></td><td></td><td></td><td></td><td></td><td></td><td></td><td></td><td></td><td></td><td>39</td><td>37</td><td>35</td><td>33</td></tr> <tr><td>73</td><td></td><td></td><td>32</td><td></td><td></td><td></td><td></td><td>29</td><td></td><td></td><td></td><td></td><td></td><td>24</td><td>23</td><td>21</td><td>18</td></tr> <tr><td></td><td></td><td></td><td></td><td>15</td><td></td><td></td><td></td><td></td><td></td><td></td><td></td><td></td><td></td><td>7</td><td>6</td><td>5</td><td>4</td><td>3</td><td></td></tr> </table>															59	57	55	53		50	49	48											39	37	35	33	73			32					29						24	23	21	18					15										7	6	5	4	3							
														59	57	55	53																																																																						
	50	49	48											39	37	35	33																																																																						
73			32					29						24	23	21	18																																																																						
				15										7	6	5	4	3																																																																					
AVAILABLE	NOT APPLICABLE	34566-4303	G	0	A	BLACK	<table border="1"> <tr><td></td><td></td><td>70</td><td>69</td><td>68</td><td>67</td><td></td><td>65</td><td>64</td><td>63</td><td></td><td>61</td><td>59</td><td>58</td><td>57</td><td>56</td><td></td><td></td><td></td><td></td></tr> <tr><td></td><td></td><td>50</td><td>49</td><td>48</td><td>47</td><td></td><td></td><td></td><td></td><td></td><td>41</td><td></td><td></td><td>38</td><td>37</td><td>36</td><td></td><td>34</td><td>33</td></tr> <tr><td></td><td></td><td></td><td>32</td><td>31</td><td>30</td><td>29</td><td>28</td><td>27</td><td></td><td></td><td></td><td>24</td><td>23</td><td></td><td></td><td>20</td><td>19</td><td>18</td><td></td></tr> <tr><td>73</td><td></td><td></td><td></td><td></td><td>16</td><td></td><td></td><td></td><td></td><td></td><td>13</td><td>12</td><td>11</td><td>10</td><td>9</td><td></td><td></td><td></td><td>1</td></tr> </table>			70	69	68	67		65	64	63		61	59	58	57	56							50	49	48	47						41			38	37	36		34	33				32	31	30	29	28	27				24	23			20	19	18		73					16						13	12	11	10	9				1
		70	69	68	67		65	64	63		61	59	58	57	56																																																																								
		50	49	48	47						41			38	37	36		34	33																																																																				
			32	31	30	29	28	27				24	23			20	19	18																																																																					
73					16						13	12	11	10	9				1																																																																				

SEE NEXT PAGE FOR ADDITIONAL NUMBERS

ENTER DESCRIPTION IEC NO: UAU2014-0574 DRAWN: SKRAJENDRANA 2013/10/08 CHKD: APPR: VIOSHY 2013/10/09 REV:	QUALITY SYMBOLS	GENERAL TOLERANCES (UNLESS SPECIFIED)	DIMENSION STYLE	SCALE	DESIGN UNITS	THIRD ANGLE PROJECTION
	▽=0	mm INCH	MM ONLY		METRIC	
	▽=0	4 PLACES +--- +---	DRAWN BY: SKRAJENDRANA 2011/02/14	DATE	TITLE	
	▽=0	3 PLACES +--- +---	CHECKED BY: MVANSLAMBROU 2011/02/14	DATE		
▽=0	2 PLACES +--- +---	1 PLACE +--- +---	APPROVED BY: DATE			
▽=0	0 PLACE +--- +---	ANGULAR +--- +---	MATERIAL NO.	DOCUMENT NO.		
GO	DRAFT WHERE APPLICABLE MUST REMAIN WITHIN DIMENSIONS	SEE BOM TABLE				

MX123
66/73/80CKT
HRNS CONN ASSY

molex

SD-34566-001

SHEET NO.
7 OF 68

THIS DRAWING CONTAINS INFORMATION THAT IS PROPRIETARY TO MOLEX INCORPORATED AND SHOULD NOT BE USED WITHOUT WRITTEN PERMISSION

STATUS	GM PART #	MATERIAL #	PART/MATERIAL REVISION	WIRE DRESS OPTION	KEY OPTION	COLOR (TPA)	NUMBERS INDICATE CAVITIES OPEN FOR CIRCUITS																																																																																																				
AVAILABLE	NOT APPLICABLE	34566-5203	G	0	A	BLACK	<table border="1"> <tr><td>72</td><td>71</td><td>69</td><td>68</td><td>67</td><td>66</td><td>64</td><td>63</td><td>62</td><td></td><td>59</td><td>58</td><td>57</td><td>56</td><td>54</td><td>53</td></tr> <tr><td>52</td><td>51</td><td>50</td><td>49</td><td>48</td><td>47</td><td>46</td><td>44</td><td>43</td><td>42</td><td></td><td>39</td><td>38</td><td>37</td><td>36</td><td>35</td><td>34</td><td>33</td></tr> <tr><td></td><td></td><td></td><td></td><td></td><td></td><td></td><td></td><td></td><td></td><td></td><td>24</td><td>23</td><td>22</td><td>21</td><td>20</td><td>19</td><td>17</td></tr> <tr><td>73</td><td></td><td></td><td></td><td></td><td></td><td></td><td></td><td></td><td></td><td></td><td></td><td></td><td></td><td></td><td></td><td></td><td></td></tr> <tr><td></td><td></td><td></td><td></td><td></td><td></td><td></td><td></td><td></td><td></td><td></td><td>9</td><td>8</td><td>7</td><td>6</td><td>5</td><td>4</td><td>3</td><td>2</td><td>1</td></tr> </table>	72	71	69	68	67	66	64	63	62		59	58	57	56	54	53	52	51	50	49	48	47	46	44	43	42		39	38	37	36	35	34	33												24	23	22	21	20	19	17	73																													9	8	7	6	5	4	3	2	1										
72	71	69	68	67	66	64	63	62		59	58	57	56	54	53																																																																																												
52	51	50	49	48	47	46	44	43	42		39	38	37	36	35	34	33																																																																																										
											24	23	22	21	20	19	17																																																																																										
73																																																																																																											
											9	8	7	6	5	4	3	2	1																																																																																								
AVAILABLE	NOT APPLICABLE	34566-5303	G	0	B	ST GRY	<table border="1"> <tr><td></td><td></td><td></td><td></td><td></td><td></td><td>65</td><td>64</td><td></td><td></td><td></td><td>59</td><td>57</td><td>55</td><td>53</td><td></td><td></td><td></td><td></td><td></td></tr> <tr><td></td><td></td><td></td><td>50</td><td>49</td><td>48</td><td>46</td><td></td><td></td><td></td><td></td><td>39</td><td>37</td><td>35</td><td>33</td><td></td><td></td><td></td><td></td><td></td></tr> <tr><td></td><td></td><td></td><td></td><td></td><td></td><td></td><td></td><td></td><td></td><td></td><td>23</td><td>21</td><td></td><td></td><td></td><td></td><td></td><td></td><td></td></tr> <tr><td>73</td><td></td><td></td><td></td><td></td><td></td><td></td><td></td><td></td><td></td><td></td><td></td><td></td><td></td><td></td><td></td><td></td><td></td><td></td><td></td></tr> <tr><td></td><td></td><td></td><td></td><td></td><td></td><td></td><td></td><td></td><td></td><td></td><td>7</td><td>6</td><td>5</td><td>4</td><td>3</td><td></td><td></td><td></td><td></td></tr> </table>							65	64				59	57	55	53									50	49	48	46					39	37	35	33																	23	21								73																															7	6	5	4	3				
						65	64				59	57	55	53																																																																																													
			50	49	48	46					39	37	35	33																																																																																													
											23	21																																																																																															
73																																																																																																											
											7	6	5	4	3																																																																																												
AVAILABLE	NOT APPLICABLE	34566-5403	G	0	B	ST GRY	<table border="1"> <tr><td></td><td></td><td></td><td></td><td></td><td></td><td>65</td><td></td><td></td><td></td><td></td><td>59</td><td>58</td><td>57</td><td>56</td><td>55</td><td>53</td><td></td><td></td><td></td></tr> <tr><td></td><td></td><td></td><td>50</td><td>49</td><td>48</td><td>46</td><td>45</td><td></td><td></td><td></td><td>39</td><td>38</td><td>37</td><td></td><td>35</td><td>34</td><td>33</td><td></td><td></td></tr> <tr><td></td><td></td><td></td><td></td><td></td><td></td><td></td><td></td><td></td><td></td><td></td><td>23</td><td>22</td><td>21</td><td></td><td></td><td>18</td><td></td><td></td><td></td></tr> <tr><td>73</td><td></td><td></td><td></td><td></td><td></td><td></td><td></td><td></td><td></td><td></td><td></td><td></td><td></td><td></td><td></td><td></td><td></td><td></td><td></td></tr> <tr><td></td><td></td><td></td><td></td><td></td><td></td><td></td><td></td><td></td><td></td><td></td><td>7</td><td>6</td><td>5</td><td>4</td><td>3</td><td></td><td></td><td></td><td></td></tr> </table>							65					59	58	57	56	55	53							50	49	48	46	45				39	38	37		35	34	33														23	22	21			18				73																															7	6	5	4	3				
						65					59	58	57	56	55	53																																																																																											
			50	49	48	46	45				39	38	37		35	34	33																																																																																										
											23	22	21			18																																																																																											
73																																																																																																											
											7	6	5	4	3																																																																																												
AVAILABLE	NOT APPLICABLE	34566-5503	G	0	A	BLACK	<table border="1"> <tr><td>72</td><td>71</td><td>69</td><td>68</td><td>67</td><td>66</td><td>64</td><td>63</td><td>62</td><td></td><td>60</td><td>59</td><td></td><td></td><td></td><td></td><td></td><td></td><td></td><td></td></tr> <tr><td>52</td><td></td><td>49</td><td>48</td><td>46</td><td></td><td>44</td><td>43</td><td>42</td><td></td><td>40</td><td>39</td><td></td><td></td><td></td><td></td><td>35</td><td>34</td><td>33</td><td></td></tr> <tr><td></td><td></td><td></td><td></td><td></td><td></td><td></td><td></td><td></td><td></td><td></td><td>24</td><td>23</td><td></td><td></td><td></td><td></td><td></td><td></td><td>17</td></tr> <tr><td>73</td><td></td><td></td><td></td><td></td><td></td><td></td><td></td><td></td><td></td><td></td><td></td><td></td><td></td><td></td><td></td><td></td><td></td><td></td><td></td></tr> <tr><td></td><td></td><td></td><td></td><td></td><td></td><td></td><td></td><td></td><td></td><td></td><td>9</td><td>8</td><td>7</td><td>6</td><td>5</td><td>4</td><td>3</td><td>2</td><td>1</td></tr> </table>	72	71	69	68	67	66	64	63	62		60	59									52		49	48	46		44	43	42		40	39					35	34	33													24	23							17	73																															9	8	7	6	5	4	3	2	1
72	71	69	68	67	66	64	63	62		60	59																																																																																																
52		49	48	46		44	43	42		40	39					35	34	33																																																																																									
											24	23							17																																																																																								
73																																																																																																											
											9	8	7	6	5	4	3	2	1																																																																																								
AVAILABLE	NOT APPLICABLE	34566-5603						SEE 34566-2503																																																																																																			
AVAILABLE	NOT APPLICABLE	34566-5703	G	0	B	ST GRY	<table border="1"> <tr><td></td><td></td><td></td><td></td><td></td><td></td><td>68</td><td></td><td></td><td></td><td></td><td>59</td><td>57</td><td>55</td><td>53</td><td></td><td></td><td></td><td></td><td></td></tr> <tr><td></td><td></td><td></td><td></td><td></td><td></td><td></td><td></td><td></td><td></td><td></td><td>39</td><td>37</td><td>35</td><td>33</td><td></td><td></td><td></td><td></td><td></td></tr> <tr><td></td><td></td><td></td><td></td><td></td><td></td><td></td><td></td><td></td><td></td><td></td><td>23</td><td>21</td><td></td><td>18</td><td>17</td><td></td><td></td><td></td><td></td></tr> <tr><td>73</td><td></td><td></td><td></td><td></td><td></td><td></td><td></td><td></td><td></td><td></td><td></td><td></td><td></td><td></td><td></td><td></td><td></td><td></td><td></td></tr> <tr><td></td><td></td><td></td><td></td><td></td><td></td><td></td><td></td><td></td><td></td><td></td><td>12</td><td>11</td><td>10</td><td></td><td></td><td></td><td></td><td></td><td></td></tr> </table>							68					59	57	55	53																	39	37	35	33																	23	21		18	17					73																															12	11	10						
						68					59	57	55	53																																																																																													
											39	37	35	33																																																																																													
											23	21		18	17																																																																																												
73																																																																																																											
											12	11	10																																																																																														
AVAILABLE	NOT APPLICABLE	34566-5803	G	0	B	ST GRY	<table border="1"> <tr><td></td><td></td><td></td><td></td><td></td><td></td><td>65</td><td></td><td></td><td></td><td></td><td>59</td><td>57</td><td>55</td><td>53</td><td></td><td></td><td></td><td></td><td></td></tr> <tr><td></td><td></td><td></td><td></td><td></td><td></td><td></td><td></td><td></td><td></td><td></td><td>39</td><td>37</td><td>35</td><td>33</td><td></td><td></td><td></td><td></td><td></td></tr> <tr><td></td><td></td><td></td><td></td><td></td><td></td><td></td><td></td><td></td><td></td><td></td><td>23</td><td>21</td><td></td><td></td><td>17</td><td></td><td></td><td></td><td></td></tr> <tr><td>73</td><td></td><td></td><td></td><td></td><td></td><td></td><td></td><td></td><td></td><td></td><td></td><td></td><td></td><td></td><td></td><td></td><td></td><td></td><td></td></tr> <tr><td></td><td></td><td></td><td></td><td></td><td></td><td></td><td></td><td></td><td></td><td></td><td>7</td><td></td><td></td><td></td><td></td><td></td><td></td><td></td><td></td></tr> </table>							65					59	57	55	53																	39	37	35	33																	23	21			17					73																															7								
						65					59	57	55	53																																																																																													
											39	37	35	33																																																																																													
											23	21			17																																																																																												
73																																																																																																											
											7																																																																																																
AVAILABLE	NOT APPLICABLE	34566-5903	G	0	A	BLACK	<table border="1"> <tr><td>72</td><td>71</td><td>69</td><td>68</td><td>67</td><td>66</td><td>64</td><td>63</td><td>62</td><td></td><td>59</td><td></td><td></td><td></td><td></td><td></td><td></td><td></td><td></td><td></td></tr> <tr><td></td><td></td><td></td><td></td><td></td><td></td><td></td><td></td><td></td><td></td><td>39</td><td></td><td></td><td></td><td></td><td></td><td>35</td><td>34</td><td>33</td><td></td></tr> <tr><td></td><td></td><td></td><td></td><td></td><td></td><td></td><td></td><td></td><td></td><td></td><td>23</td><td></td><td></td><td></td><td></td><td></td><td></td><td></td><td>17</td></tr> <tr><td>73</td><td></td><td></td><td></td><td></td><td></td><td></td><td></td><td></td><td></td><td></td><td></td><td></td><td></td><td></td><td></td><td></td><td></td><td></td><td></td></tr> <tr><td></td><td></td><td></td><td></td><td></td><td></td><td></td><td></td><td></td><td></td><td></td><td>9</td><td>8</td><td></td><td></td><td>5</td><td>4</td><td>3</td><td>2</td><td>1</td></tr> </table>	72	71	69	68	67	66	64	63	62		59																				39						35	34	33													23								17	73																															9	8			5	4	3	2	1
72	71	69	68	67	66	64	63	62		59																																																																																																	
										39						35	34	33																																																																																									
											23								17																																																																																								
73																																																																																																											
											9	8			5	4	3	2	1																																																																																								
SEE NEXT PAGE FOR ADDITIONAL NUMBERS																																																																																																											

ENTER DESCRIPTION IEC NO: UAU2014-0574 DRAWN: SKRAJENDRANA 2013/10/08 CHKD: APPR: VIOSHY 2013/10/09 REV: GO	QUALITY SYMBOLS	GENERAL TOLERANCES (UNLESS SPECIFIED)	DIMENSION STYLE	SCALE	DESIGN UNITS	THIRD ANGLE PROJECTION	
	∇=0 ∇=0 ∇=0	4 PLACES ± --- INCH 3 PLACES ± --- INCH 2 PLACES ± --- INCH 1 PLACE ± --- INCH 0 PLACE ± --- INCH	mm INCH mm INCH mm INCH mm INCH	MM ONLY		METRIC	DRAWN BY: SKRAJENDRANA 2011/02/14 CHECKED BY: MYANSLAMBROU 2011/02/14 APPROVED BY:
		ANGULAR ± ---°	SEE BOM TABLE				MX123 66/73/80CKT HRNS CONN ASSY molex SD-34566-001
		DRAFT WHERE APPLICABLE MUST REMAIN WITHIN DIMENSIONS	SEE BOM TABLE				SHEET NO. 9 OF 68 THIS DRAWING CONTAINS INFORMATION THAT IS PROPRIETARY TO MOLEX INCORPORATED AND SHOULD NOT BE USED WITHOUT WRITTEN PERMISSION

STATUS	GM PART #	MATERIAL #	PART/MATERIAL REVISION	WIRE DRESS OPTION	KEY OPTION	COLOR (TPA)	NUMBERS INDICATE CAVITIES OPEN FOR CIRCUITS																																																																											
AVAILABLE	NOT APPLICABLE	34566-9203	G	0	A	BLACK	<table border="1"> <tr><td>72</td><td>71</td><td>70</td><td>69</td><td>68</td><td>67</td><td>66</td><td>64</td><td>63</td><td>62</td><td>60</td><td>59</td><td></td><td></td><td>55</td><td>54</td><td>53</td></tr> <tr><td>52</td><td></td><td></td><td>49</td><td>48</td><td></td><td></td><td>44</td><td>43</td><td>42</td><td>40</td><td>39</td><td>38</td><td></td><td>35</td><td>34</td><td>33</td></tr> <tr><td></td><td></td><td>73</td><td></td><td></td><td></td><td>30</td><td>29</td><td>28</td><td>27</td><td></td><td>24</td><td>23</td><td></td><td>19</td><td>18</td><td>17</td></tr> <tr><td></td><td></td><td></td><td>16</td><td></td><td></td><td>13</td><td>12</td><td>11</td><td></td><td>9</td><td>8</td><td>7</td><td>6</td><td>5</td><td>4</td><td>3</td><td>2</td><td>1</td></tr> </table>	72	71	70	69	68	67	66	64	63	62	60	59			55	54	53	52			49	48			44	43	42	40	39	38		35	34	33			73				30	29	28	27		24	23		19	18	17				16			13	12	11		9	8	7	6	5	4	3	2	1					
72	71	70	69	68	67	66	64	63	62	60	59			55	54	53																																																																		
52			49	48			44	43	42	40	39	38		35	34	33																																																																		
		73				30	29	28	27		24	23		19	18	17																																																																		
			16			13	12	11		9	8	7	6	5	4	3	2	1																																																																
AVAILABLE	NOT APPLICABLE	34566-9303	G	0	A	BLACK	<table border="1"> <tr><td>72</td><td>71</td><td></td><td>69</td><td>68</td><td>67</td><td>66</td><td>64</td><td>63</td><td>62</td><td></td><td>59</td><td>58</td><td>57</td><td>56</td><td>55</td><td>54</td><td>53</td></tr> <tr><td>52</td><td>51</td><td>50</td><td>49</td><td>48</td><td>47</td><td>46</td><td>44</td><td>43</td><td>42</td><td></td><td>39</td><td>38</td><td>37</td><td>36</td><td>35</td><td>34</td><td>33</td></tr> <tr><td></td><td></td><td>73</td><td></td><td>32</td><td>31</td><td>30</td><td>29</td><td>27</td><td></td><td></td><td>24</td><td>23</td><td>22</td><td>21</td><td>20</td><td>19</td><td>17</td></tr> <tr><td></td><td></td><td></td><td>15</td><td>14</td><td>13</td><td>12</td><td>11</td><td></td><td></td><td>9</td><td>8</td><td>7</td><td>6</td><td>5</td><td>4</td><td>3</td><td>2</td><td>1</td></tr> </table>	72	71		69	68	67	66	64	63	62		59	58	57	56	55	54	53	52	51	50	49	48	47	46	44	43	42		39	38	37	36	35	34	33			73		32	31	30	29	27			24	23	22	21	20	19	17				15	14	13	12	11			9	8	7	6	5	4	3	2	1		
72	71		69	68	67	66	64	63	62		59	58	57	56	55	54	53																																																																	
52	51	50	49	48	47	46	44	43	42		39	38	37	36	35	34	33																																																																	
		73		32	31	30	29	27			24	23	22	21	20	19	17																																																																	
			15	14	13	12	11			9	8	7	6	5	4	3	2	1																																																																
AVAILABLE	NOT APPLICABLE	34566-9403	G	0	B	ST GRY	<table border="1"> <tr><td></td><td></td><td></td><td>68</td><td>67</td><td>66</td><td>65</td><td></td><td></td><td></td><td></td><td>59</td><td>58</td><td>57</td><td></td><td></td><td>54</td><td>53</td></tr> <tr><td></td><td>51</td><td>50</td><td>49</td><td>48</td><td>46</td><td>45</td><td>43</td><td>42</td><td>41</td><td></td><td>40</td><td>39</td><td>38</td><td>37</td><td></td><td>35</td><td>33</td></tr> <tr><td></td><td></td><td>73</td><td></td><td>32</td><td>31</td><td>30</td><td></td><td></td><td>26</td><td></td><td>24</td><td>23</td><td>22</td><td></td><td>20</td><td></td><td></td></tr> <tr><td></td><td></td><td></td><td>16</td><td></td><td></td><td>13</td><td></td><td></td><td>10</td><td>9</td><td>8</td><td>7</td><td>6</td><td>5</td><td>4</td><td></td><td></td></tr> </table>				68	67	66	65					59	58	57			54	53		51	50	49	48	46	45	43	42	41		40	39	38	37		35	33			73		32	31	30			26		24	23	22		20						16			13			10	9	8	7	6	5	4					
			68	67	66	65					59	58	57			54	53																																																																	
	51	50	49	48	46	45	43	42	41		40	39	38	37		35	33																																																																	
		73		32	31	30			26		24	23	22		20																																																																			
			16			13			10	9	8	7	6	5	4																																																																			
AVAILABLE	NOT APPLICABLE	34566-9503	G	0	A	BLACK	<table border="1"> <tr><td>72</td><td>71</td><td>70</td><td>69</td><td>68</td><td></td><td></td><td>65</td><td>64</td><td>63</td><td>61</td><td>59</td><td>58</td><td>57</td><td>56</td><td></td><td></td><td></td></tr> <tr><td>52</td><td>51</td><td></td><td>49</td><td></td><td>47</td><td></td><td></td><td></td><td></td><td>41</td><td></td><td></td><td>38</td><td>37</td><td>36</td><td>34</td><td>33</td></tr> <tr><td></td><td></td><td>73</td><td></td><td>32</td><td>31</td><td>30</td><td>29</td><td>28</td><td>27</td><td></td><td>24</td><td>23</td><td></td><td></td><td>20</td><td>19</td><td>18</td><td>17</td></tr> <tr><td></td><td></td><td></td><td>16</td><td></td><td></td><td>13</td><td>12</td><td>11</td><td>10</td><td>9</td><td></td><td></td><td></td><td></td><td></td><td></td><td></td><td>1</td></tr> </table>	72	71	70	69	68			65	64	63	61	59	58	57	56				52	51		49		47					41			38	37	36	34	33			73		32	31	30	29	28	27		24	23			20	19	18	17				16			13	12	11	10	9								1	
72	71	70	69	68			65	64	63	61	59	58	57	56																																																																				
52	51		49		47					41			38	37	36	34	33																																																																	
		73		32	31	30	29	28	27		24	23			20	19	18	17																																																																
			16			13	12	11	10	9								1																																																																
AVAILABLE	NOT APPLICABLE	34566-9603	G	0	A	BLACK	<table border="1"> <tr><td></td><td>71</td><td>70</td><td>69</td><td>68</td><td></td><td>66</td><td>65</td><td>64</td><td>63</td><td>61</td><td>59</td><td>58</td><td>57</td><td>56</td><td></td><td></td><td></td></tr> <tr><td>52</td><td></td><td>50</td><td>49</td><td></td><td>47</td><td></td><td></td><td></td><td></td><td>41</td><td></td><td></td><td>38</td><td>37</td><td>36</td><td>35</td><td>34</td><td>33</td></tr> <tr><td></td><td></td><td>73</td><td></td><td>32</td><td>31</td><td>30</td><td>29</td><td>28</td><td>27</td><td></td><td>24</td><td>23</td><td></td><td></td><td>20</td><td>19</td><td>18</td><td>17</td></tr> <tr><td></td><td></td><td></td><td>16</td><td>15</td><td>14</td><td>13</td><td>12</td><td>11</td><td>10</td><td>9</td><td></td><td></td><td></td><td></td><td></td><td></td><td></td><td>1</td></tr> </table>		71	70	69	68		66	65	64	63	61	59	58	57	56				52		50	49		47					41			38	37	36	35	34	33			73		32	31	30	29	28	27		24	23			20	19	18	17				16	15	14	13	12	11	10	9								1
	71	70	69	68		66	65	64	63	61	59	58	57	56																																																																				
52		50	49		47					41			38	37	36	35	34	33																																																																
		73		32	31	30	29	28	27		24	23			20	19	18	17																																																																
			16	15	14	13	12	11	10	9								1																																																																
AVAILABLE	NOT APPLICABLE	34566-9703	G	0	A	BLACK	<table border="1"> <tr><td>72</td><td>71</td><td>70</td><td>69</td><td>68</td><td></td><td></td><td>65</td><td>64</td><td>63</td><td>61</td><td>59</td><td></td><td>57</td><td>56</td><td></td><td></td><td></td></tr> <tr><td>52</td><td>51</td><td>50</td><td>49</td><td></td><td>47</td><td></td><td></td><td></td><td></td><td>41</td><td></td><td></td><td>38</td><td>37</td><td>36</td><td></td><td>34</td><td>33</td></tr> <tr><td></td><td></td><td>73</td><td></td><td>32</td><td>31</td><td>30</td><td>29</td><td>28</td><td>27</td><td></td><td>24</td><td>23</td><td></td><td></td><td>20</td><td>19</td><td>18</td><td>17</td></tr> <tr><td></td><td></td><td></td><td>16</td><td></td><td></td><td>13</td><td>12</td><td>11</td><td>10</td><td>9</td><td></td><td></td><td></td><td></td><td>3</td><td>2</td><td>1</td><td></td></tr> </table>	72	71	70	69	68			65	64	63	61	59		57	56				52	51	50	49		47					41			38	37	36		34	33			73		32	31	30	29	28	27		24	23			20	19	18	17				16			13	12	11	10	9					3	2	1	
72	71	70	69	68			65	64	63	61	59		57	56																																																																				
52	51	50	49		47					41			38	37	36		34	33																																																																
		73		32	31	30	29	28	27		24	23			20	19	18	17																																																																
			16			13	12	11	10	9					3	2	1																																																																	
AVAILABLE	NOT APPLICABLE	34566-9803	G	0	A	BLACK	<table border="1"> <tr><td>72</td><td>71</td><td>70</td><td>69</td><td>68</td><td></td><td></td><td>65</td><td>64</td><td>63</td><td>61</td><td>59</td><td></td><td>57</td><td>56</td><td></td><td></td><td></td></tr> <tr><td>52</td><td>51</td><td>50</td><td>49</td><td></td><td>47</td><td></td><td></td><td></td><td></td><td>41</td><td></td><td></td><td>38</td><td>37</td><td>36</td><td></td><td>34</td><td>33</td></tr> <tr><td></td><td></td><td>73</td><td></td><td>32</td><td>31</td><td>30</td><td>29</td><td>28</td><td>27</td><td></td><td>24</td><td>23</td><td></td><td></td><td>20</td><td>19</td><td>18</td><td>17</td></tr> <tr><td></td><td></td><td></td><td>16</td><td></td><td></td><td>13</td><td>12</td><td>11</td><td>10</td><td>9</td><td></td><td></td><td></td><td></td><td></td><td></td><td></td><td>1</td></tr> </table>	72	71	70	69	68			65	64	63	61	59		57	56				52	51	50	49		47					41			38	37	36		34	33			73		32	31	30	29	28	27		24	23			20	19	18	17				16			13	12	11	10	9								1
72	71	70	69	68			65	64	63	61	59		57	56																																																																				
52	51	50	49		47					41			38	37	36		34	33																																																																
		73		32	31	30	29	28	27		24	23			20	19	18	17																																																																
			16			13	12	11	10	9								1																																																																
AVAILABLE	NOT APPLICABLE	34566-9903	G	0	A	BLACK	<table border="1"> <tr><td></td><td>71</td><td></td><td>69</td><td>68</td><td></td><td></td><td>65</td><td>64</td><td>63</td><td>61</td><td>59</td><td>58</td><td>57</td><td>56</td><td></td><td></td><td></td></tr> <tr><td>52</td><td></td><td>50</td><td>49</td><td></td><td>47</td><td></td><td></td><td></td><td></td><td>41</td><td></td><td></td><td>38</td><td>37</td><td>36</td><td></td><td>34</td><td>33</td></tr> <tr><td></td><td></td><td>73</td><td></td><td>32</td><td>31</td><td>30</td><td>29</td><td>28</td><td>27</td><td></td><td>24</td><td>23</td><td></td><td></td><td>20</td><td>19</td><td>18</td><td>17</td></tr> <tr><td></td><td></td><td></td><td>16</td><td></td><td></td><td>13</td><td>12</td><td>11</td><td>10</td><td>9</td><td></td><td></td><td></td><td></td><td></td><td></td><td></td><td>1</td></tr> </table>		71		69	68			65	64	63	61	59	58	57	56				52		50	49		47					41			38	37	36		34	33			73		32	31	30	29	28	27		24	23			20	19	18	17				16			13	12	11	10	9								1
	71		69	68			65	64	63	61	59	58	57	56																																																																				
52		50	49		47					41			38	37	36		34	33																																																																
		73		32	31	30	29	28	27		24	23			20	19	18	17																																																																
			16			13	12	11	10	9								1																																																																

SEE NEXT PAGE FOR ADDITIONAL NUMBERS

ENTER DESCRIPTION IEC NO: UAU2014-0574 DRAWNSKRAJENDRANA 2013/10/08 CHKD: APPR:IKOSHY 2013/10/09 REV:	QUALITY SYMBOLS	GENERAL TOLERANCES (UNLESS SPECIFIED)	DIMENSION STYLE	SCALE	DESIGN UNITS	THIRD ANGLE PROJECTION
	▽=0	4 PLACES ±--- ±---	mm INCH	MM ONLY	METRIC	
	▽=0	3 PLACES ±--- ±---				
	▽=0	2 PLACES ±--- ±---				
	1 PLACE ±--- ±---					
	0 PLACE ±--- ±---					
	ANGULAR ±---°					
	DRAFT WHERE APPLICABLE MUST REMAIN WITHIN DIMENSIONS					
			DRAWN BY	DATE	TITLE	
			SKRAJENDRANA	2011/02/14		
			CHECKED BY	DATE		
			MVANS LAMBROU	2011/02/14		
			APPROVED BY	DATE		
			MATERIAL NO.	DOCUMENT NO.		
			SEE BOM TABLE	SD-34566-001		
						SHEET NO. 14 OF 68
			THIS DRAWING CONTAINS INFORMATION THAT IS PROPRIETARY TO MOLEX INCORPORATED AND SHOULD NOT BE USED WITHOUT WRITTEN PERMISSION			

STATUS	GM PART #	MATERIAL #	PART/MATERIAL REVISION	WIRE DRESS OPTION	KEY OPTION	COLOR (TPA)	NUMBERS INDICATE CAVITIES OPEN FOR CIRCUITS																																																																		
AVAILABLE	NOT APPLICABLE	34566-1193	G	0	A	BLACK	<table border="1"> <tr><td>72</td><td>71</td><td>69</td><td>68</td><td>67</td><td>66</td><td>64</td><td>63</td><td>62</td><td>60</td><td>59</td><td></td><td></td><td></td><td>54</td><td>53</td></tr> <tr><td></td><td></td><td>49</td><td>48</td><td>46</td><td>44</td><td>43</td><td>42</td><td></td><td></td><td>39</td><td></td><td></td><td></td><td>34</td><td>33</td></tr> <tr><td></td><td></td><td></td><td>32</td><td></td><td>29</td><td>27</td><td></td><td></td><td></td><td>23</td><td></td><td></td><td></td><td>17</td><td></td></tr> <tr><td></td><td>73</td><td></td><td></td><td>14</td><td>13</td><td>12</td><td>11</td><td>9</td><td>8</td><td>7</td><td>6</td><td>5</td><td>4</td><td>3</td><td>2</td><td>1</td></tr> </table>	72	71	69	68	67	66	64	63	62	60	59				54	53			49	48	46	44	43	42			39				34	33				32		29	27				23				17			73			14	13	12	11	9	8	7	6	5	4	3	2	1	
72	71	69	68	67	66	64	63	62	60	59				54	53																																																										
		49	48	46	44	43	42			39				34	33																																																										
			32		29	27				23				17																																																											
	73			14	13	12	11	9	8	7	6	5	4	3	2	1																																																									
AVAILABLE	NOT APPLICABLE	34566-1213	G	0	A	BLACK	<table border="1"> <tr><td>72</td><td>71</td><td>69</td><td>68</td><td>67</td><td>66</td><td>64</td><td>63</td><td>62</td><td></td><td>59</td><td></td><td></td><td></td><td>54</td><td>53</td></tr> <tr><td></td><td></td><td></td><td>48</td><td></td><td>46</td><td>44</td><td>43</td><td>42</td><td></td><td>39</td><td></td><td></td><td></td><td>34</td><td>33</td></tr> <tr><td></td><td></td><td></td><td></td><td>32</td><td></td><td>29</td><td>27</td><td></td><td></td><td>24</td><td>23</td><td></td><td></td><td>17</td><td></td></tr> <tr><td></td><td>73</td><td></td><td></td><td></td><td>14</td><td>13</td><td>12</td><td>11</td><td>9</td><td>8</td><td></td><td></td><td>5</td><td>4</td><td>3</td><td>2</td><td>1</td></tr> </table>	72	71	69	68	67	66	64	63	62		59				54	53				48		46	44	43	42		39				34	33					32		29	27			24	23			17			73				14	13	12	11	9	8			5	4	3	2	1
72	71	69	68	67	66	64	63	62		59				54	53																																																										
			48		46	44	43	42		39				34	33																																																										
				32		29	27			24	23			17																																																											
	73				14	13	12	11	9	8			5	4	3	2	1																																																								
AVAILABLE	NOT APPLICABLE	34566-1223	G	0	B	ST GRY	<table border="1"> <tr><td></td><td></td><td></td><td></td><td>67</td><td>66</td><td>65</td><td>63</td><td>62</td><td></td><td>59</td><td>57</td><td>55</td><td>53</td><td></td><td></td></tr> <tr><td></td><td></td><td></td><td>48</td><td></td><td></td><td></td><td>43</td><td>42</td><td></td><td>39</td><td>37</td><td>35</td><td>33</td><td></td><td></td></tr> <tr><td></td><td></td><td></td><td></td><td></td><td></td><td>29</td><td>27</td><td>26</td><td></td><td>23</td><td>21</td><td></td><td>17</td><td></td><td></td></tr> <tr><td></td><td>73</td><td></td><td></td><td></td><td></td><td></td><td>12</td><td></td><td>9</td><td>7</td><td></td><td></td><td></td><td></td><td></td></tr> </table>					67	66	65	63	62		59	57	55	53						48				43	42		39	37	35	33									29	27	26		23	21		17				73						12		9	7							
				67	66	65	63	62		59	57	55	53																																																												
			48				43	42		39	37	35	33																																																												
						29	27	26		23	21		17																																																												
	73						12		9	7																																																															
AVAILABLE	NOT APPLICABLE	34566-1233	G	0	B	ST GRY	<table border="1"> <tr><td></td><td></td><td></td><td></td><td></td><td>65</td><td></td><td>62</td><td></td><td>59</td><td>57</td><td>55</td><td>53</td><td></td><td></td></tr> <tr><td></td><td></td><td></td><td>48</td><td>46</td><td></td><td></td><td>42</td><td></td><td>39</td><td>37</td><td>35</td><td>33</td><td></td><td></td></tr> <tr><td></td><td></td><td></td><td></td><td></td><td>29</td><td></td><td>26</td><td></td><td>23</td><td>21</td><td></td><td>17</td><td></td><td></td></tr> <tr><td></td><td>73</td><td></td><td></td><td></td><td></td><td>12</td><td></td><td>9</td><td>7</td><td></td><td></td><td></td><td></td><td></td></tr> </table>						65		62		59	57	55	53						48	46			42		39	37	35	33								29		26		23	21		17				73					12		9	7											
					65		62		59	57	55	53																																																													
			48	46			42		39	37	35	33																																																													
					29		26		23	21		17																																																													
	73					12		9	7																																																																
AVAILABLE	NOT APPLICABLE	34566-1243	G	0	B	ST GRY	<table border="1"> <tr><td></td><td></td><td></td><td></td><td></td><td></td><td></td><td></td><td></td><td>59</td><td>57</td><td>55</td><td>53</td><td></td><td></td></tr> <tr><td></td><td>50</td><td>48</td><td>46</td><td></td><td></td><td></td><td></td><td></td><td>39</td><td>37</td><td>35</td><td>33</td><td></td><td></td></tr> <tr><td></td><td></td><td></td><td></td><td>29</td><td></td><td></td><td></td><td></td><td>23</td><td>21</td><td></td><td>17</td><td></td><td></td></tr> <tr><td></td><td>73</td><td></td><td></td><td>15</td><td></td><td>12</td><td></td><td></td><td>7</td><td>6</td><td>5</td><td>4</td><td>3</td><td></td></tr> </table>										59	57	55	53				50	48	46						39	37	35	33							29					23	21		17				73			15		12			7	6	5	4	3							
									59	57	55	53																																																													
	50	48	46						39	37	35	33																																																													
				29					23	21		17																																																													
	73			15		12			7	6	5	4	3																																																												
AVAILABLE	NOT APPLICABLE	34566-1253	G	9	B	ST GRY	<table border="1"> <tr><td></td><td></td><td>49</td><td>48</td><td>46</td><td>65</td><td></td><td></td><td></td><td>60</td><td>59</td><td>57</td><td>55</td><td>53</td><td></td><td></td></tr> <tr><td></td><td></td><td></td><td></td><td></td><td></td><td></td><td></td><td></td><td>40</td><td>39</td><td>37</td><td>35</td><td>33</td><td></td><td></td></tr> <tr><td></td><td></td><td></td><td></td><td></td><td></td><td></td><td></td><td></td><td>24</td><td>23</td><td>21</td><td></td><td></td><td>2</td><td></td></tr> <tr><td></td><td>73</td><td></td><td></td><td></td><td></td><td></td><td></td><td></td><td></td><td></td><td></td><td></td><td></td><td></td><td></td></tr> </table>			49	48	46	65				60	59	57	55	53												40	39	37	35	33												24	23	21			2			73																
		49	48	46	65				60	59	57	55	53																																																												
									40	39	37	35	33																																																												
									24	23	21			2																																																											
	73																																																																								
AVAILABLE	NOT APPLICABLE	34566-1263	G	9	A	BLACK	<p>NUMBERS IN BOLD MUST USE SAE WIRE MEETING SAE J1128, WIRE SIZE (NO.20) OR (NO.18 MAX. O.D. OF 2.06 MM) PER G.M. DRAWING NUMBER 12582682.</p> <table border="1"> <tr><td>72</td><td>71</td><td>69</td><td>68</td><td>67</td><td>66</td><td>64</td><td>63</td><td>62</td><td></td><td>59</td><td></td><td>56</td><td></td><td>53</td></tr> <tr><td></td><td>50</td><td>48</td><td>46</td><td>44</td><td>43</td><td>42</td><td></td><td></td><td></td><td>39</td><td></td><td>36</td><td>35</td><td>33</td></tr> <tr><td></td><td></td><td></td><td>32</td><td>30</td><td>29</td><td>27</td><td></td><td></td><td></td><td>24</td><td>23</td><td></td><td>20</td><td>17</td></tr> <tr><td></td><td>73</td><td></td><td></td><td>14</td><td>13</td><td>12</td><td>11</td><td>9</td><td>8</td><td></td><td></td><td>5</td><td>4</td><td>3</td><td>2</td><td>1</td></tr> </table>	72	71	69	68	67	66	64	63	62		59		56		53		50	48	46	44	43	42				39		36	35	33				32	30	29	27				24	23		20	17		73			14	13	12	11	9	8			5	4	3	2	1				
72	71	69	68	67	66	64	63	62		59		56		53																																																											
	50	48	46	44	43	42				39		36	35	33																																																											
			32	30	29	27				24	23		20	17																																																											
	73			14	13	12	11	9	8			5	4	3	2	1																																																									
AVAILABLE	NOT APPLICABLE	34566-1273	G	0	A	BLACK	<table border="1"> <tr><td></td><td>70</td><td>69</td><td>68</td><td></td><td>65</td><td>64</td><td>63</td><td>61</td><td>59</td><td>58</td><td>57</td><td>56</td><td></td><td></td><td></td></tr> <tr><td>52</td><td>50</td><td>49</td><td>48</td><td>47</td><td></td><td></td><td></td><td>41</td><td></td><td></td><td>38</td><td>37</td><td>36</td><td>34</td><td>33</td></tr> <tr><td></td><td></td><td></td><td>32</td><td>31</td><td>30</td><td>29</td><td>28</td><td>27</td><td></td><td>24</td><td>23</td><td></td><td>20</td><td>19</td><td>18</td></tr> <tr><td></td><td>73</td><td></td><td></td><td>16</td><td></td><td>13</td><td>12</td><td>11</td><td>10</td><td>9</td><td></td><td></td><td></td><td></td><td>1</td></tr> </table>		70	69	68		65	64	63	61	59	58	57	56				52	50	49	48	47				41			38	37	36	34	33				32	31	30	29	28	27		24	23		20	19	18		73			16		13	12	11	10	9					1		
	70	69	68		65	64	63	61	59	58	57	56																																																													
52	50	49	48	47				41			38	37	36	34	33																																																										
			32	31	30	29	28	27		24	23		20	19	18																																																										
	73			16		13	12	11	10	9					1																																																										

ENTER DESCRIPTION IEC NO: UAU2014-0574 DRAWNS: SKRAJENDRANA 2013/10/08 CHKD: APPR: VIKASHY REV: 2013/10/09	QUALITY SYMBOLS	GENERAL TOLERANCES (UNLESS SPECIFIED)	DIMENSION STYLE	SCALE	DESIGN UNITS	THIRD ANGLE PROJECTION	
	∇=0 ∇=0 ∇=0	4 PLACES ± --- INCH 3 PLACES ± --- INCH 2 PLACES ± --- INCH 1 PLACE ± --- INCH 0 PLACE ± --- INCH	mm INCH ANGULAR ± ---° DRAFT WHERE APPLICABLE MUST REMAIN WITHIN DIMENSIONS	MM ONLY DRAWN BY: SKRAJENDRANA 2011/02/14 CHECKED BY: MVANSLAMBROU 2011/02/14 APPROVED BY:	DATE	METRIC	MX123 66/73/80CKT HRNS CONN ASSY molex SD-34566-001
	MATERIAL NO. DOCUMENT NO.	SEE BOM TABLE	SHEET NO. 17 OF 68	THIS DRAWING CONTAINS INFORMATION THAT IS PROPRIETARY TO MOLEX INCORPORATED AND SHOULD NOT BE USED WITHOUT WRITTEN PERMISSION			
	GO						

STATUS	GM PART #	MATERIAL #	PART/ MATERIAL REVISION	WIRE DRESS OPTION	KEY OPTION ▽	COLOR (TPAL) ▽	NUMBERS INDICATE CAVITIES OPEN FOR CIRCUITS ▽																																																																													
AVAILABLE	NOT APPLICABLE	34566-1283	G	0	A	BLACK	<table border="1"> <tr><td>72</td><td>71</td><td>70</td><td>69</td><td>68</td><td>66</td><td>65</td><td>64</td><td>63</td><td>61</td><td>59</td><td>58</td><td>57</td><td>56</td><td>54</td></tr> <tr><td>52</td><td>50</td><td>49</td><td>48</td><td>47</td><td></td><td></td><td></td><td></td><td>42</td><td>41</td><td>38</td><td>37</td><td>36</td><td>34</td><td>33</td></tr> <tr><td colspan="2">73</td><td>32</td><td>31</td><td>30</td><td>29</td><td>28</td><td>27</td><td>26</td><td>24</td><td>23</td><td></td><td></td><td>20</td><td>19</td><td>18</td></tr> <tr><td></td><td></td><td>16</td><td></td><td></td><td>13</td><td>12</td><td>11</td><td>10</td><td>9</td><td></td><td></td><td></td><td></td><td></td><td></td></tr> </table>	72	71	70	69	68	66	65	64	63	61	59	58	57	56	54	52	50	49	48	47					42	41	38	37	36	34	33	73		32	31	30	29	28	27	26	24	23			20	19	18			16			13	12	11	10	9																				
72	71	70	69	68	66	65	64	63	61	59	58	57	56	54																																																																						
52	50	49	48	47					42	41	38	37	36	34	33																																																																					
73		32	31	30	29	28	27	26	24	23			20	19	18																																																																					
		16			13	12	11	10	9																																																																											
AVAILABLE	NOT APPLICABLE	34566-1293	G	0	A	BLACK	<table border="1"> <tr><td></td><td></td><td></td><td>68</td><td></td><td>65</td><td>63</td><td>61</td><td>59</td><td>58</td><td>56</td><td></td><td></td><td></td><td></td><td></td></tr> <tr><td>52</td><td>50</td><td></td><td>47</td><td></td><td></td><td></td><td>41</td><td></td><td>38</td><td>37</td><td>36</td><td></td><td>34</td><td>33</td><td></td></tr> <tr><td colspan="2">73</td><td>32</td><td>31</td><td>30</td><td>29</td><td>28</td><td>27</td><td>24</td><td>23</td><td></td><td></td><td>20</td><td>19</td><td>18</td><td>17</td></tr> <tr><td></td><td></td><td>16</td><td></td><td></td><td>13</td><td>12</td><td>11</td><td>10</td><td>9</td><td></td><td></td><td></td><td></td><td></td><td>1</td></tr> </table>				68		65	63	61	59	58	56						52	50		47				41		38	37	36		34	33		73		32	31	30	29	28	27	24	23			20	19	18	17			16			13	12	11	10	9						1													
			68		65	63	61	59	58	56																																																																										
52	50		47				41		38	37	36		34	33																																																																						
73		32	31	30	29	28	27	24	23			20	19	18	17																																																																					
		16			13	12	11	10	9						1																																																																					
AVAILABLE	NOT APPLICABLE	34566-1313	G	0	H	ST GRY	<table border="1"> <tr><td>80</td><td>78</td><td></td><td></td><td></td><td></td><td>72</td><td>71</td><td>70</td><td>69</td><td>68</td><td>66</td><td>65</td><td>64</td><td>63</td><td>61</td></tr> <tr><td></td><td>58</td><td>57</td><td>56</td><td>55</td><td>54</td><td>53</td><td></td><td></td><td></td><td></td><td>46</td><td>44</td><td>43</td><td>42</td><td></td></tr> <tr><td>40</td><td></td><td>37</td><td>35</td><td></td><td></td><td>32</td><td>30</td><td>29</td><td>27</td><td>26</td><td></td><td></td><td></td><td></td><td>21</td></tr> <tr><td>20</td><td>19</td><td>18</td><td>17</td><td>15</td><td></td><td>12</td><td></td><td></td><td></td><td>8</td><td>6</td><td>5</td><td>3</td><td>2</td><td></td></tr> </table>	80	78					72	71	70	69	68	66	65	64	63	61		58	57	56	55	54	53					46	44	43	42		40		37	35			32	30	29	27	26					21	20	19	18	17	15		12				8	6	5	3	2														
80	78					72	71	70	69	68	66	65	64	63	61																																																																					
	58	57	56	55	54	53					46	44	43	42																																																																						
40		37	35			32	30	29	27	26					21																																																																					
20	19	18	17	15		12				8	6	5	3	2																																																																						
AVAILABLE	NOT APPLICABLE	34566-1323	G	0	A	BLACK	<table border="1"> <tr><td>72</td><td>71</td><td>70</td><td>69</td><td>68</td><td>67</td><td>66</td><td>65</td><td>64</td><td>63</td><td>62</td><td>60</td><td>59</td><td>58</td><td>57</td><td>56</td><td>55</td><td>54</td><td>53</td></tr> <tr><td>52</td><td>51</td><td>50</td><td>49</td><td>48</td><td>47</td><td>46</td><td>45</td><td>44</td><td>43</td><td>42</td><td>41</td><td>40</td><td>39</td><td>38</td><td>37</td><td>36</td><td>35</td><td>34</td><td>33</td></tr> <tr><td colspan="2">73</td><td>32</td><td>31</td><td>30</td><td>29</td><td>28</td><td>27</td><td>25</td><td>24</td><td>23</td><td>22</td><td>21</td><td>20</td><td>19</td><td>18</td><td>17</td><td></td><td></td></tr> <tr><td></td><td></td><td>16</td><td>15</td><td>14</td><td>13</td><td>12</td><td>11</td><td>9</td><td>8</td><td>7</td><td>6</td><td>5</td><td>4</td><td>3</td><td>2</td><td>1</td><td></td><td></td></tr> </table>	72	71	70	69	68	67	66	65	64	63	62	60	59	58	57	56	55	54	53	52	51	50	49	48	47	46	45	44	43	42	41	40	39	38	37	36	35	34	33	73		32	31	30	29	28	27	25	24	23	22	21	20	19	18	17					16	15	14	13	12	11	9	8	7	6	5	4	3	2	1		
72	71	70	69	68	67	66	65	64	63	62	60	59	58	57	56	55	54	53																																																																		
52	51	50	49	48	47	46	45	44	43	42	41	40	39	38	37	36	35	34	33																																																																	
73		32	31	30	29	28	27	25	24	23	22	21	20	19	18	17																																																																				
		16	15	14	13	12	11	9	8	7	6	5	4	3	2	1																																																																				
AVAILABLE	NOT APPLICABLE	34566-1333	G	0	A	BLACK	<table border="1"> <tr><td></td><td></td><td>70</td><td>69</td><td>68</td><td></td><td>65</td><td>64</td><td></td><td></td><td>59</td><td>58</td><td>56</td><td></td><td></td><td></td><td></td><td></td><td></td></tr> <tr><td>52</td><td>50</td><td>49</td><td></td><td>47</td><td></td><td></td><td></td><td></td><td>41</td><td></td><td>38</td><td>37</td><td>36</td><td></td><td>34</td><td></td><td></td><td></td></tr> <tr><td colspan="2">73</td><td>32</td><td>31</td><td>30</td><td>29</td><td>28</td><td>27</td><td></td><td>23</td><td></td><td></td><td>20</td><td>19</td><td>18</td><td>17</td><td></td><td></td><td></td></tr> <tr><td></td><td></td><td>16</td><td></td><td></td><td>13</td><td>12</td><td>11</td><td>10</td><td>9</td><td>8</td><td>6</td><td></td><td></td><td></td><td></td><td></td><td></td><td>1</td></tr> </table>			70	69	68		65	64			59	58	56							52	50	49		47					41		38	37	36		34				73		32	31	30	29	28	27		23			20	19	18	17						16			13	12	11	10	9	8	6							1	
		70	69	68		65	64			59	58	56																																																																								
52	50	49		47					41		38	37	36		34																																																																					
73		32	31	30	29	28	27		23			20	19	18	17																																																																					
		16			13	12	11	10	9	8	6							1																																																																		
AVAILABLE	NOT APPLICABLE	34566-1343	G	0	A	BLACK	<table border="1"> <tr><td>72</td><td>71</td><td></td><td>69</td><td>67</td><td>65</td><td>64</td><td>63</td><td></td><td></td><td>59</td><td>58</td><td>57</td><td>56</td><td></td><td></td><td></td><td></td><td></td></tr> <tr><td></td><td>50</td><td>49</td><td>48</td><td>47</td><td></td><td></td><td></td><td>41</td><td></td><td></td><td>38</td><td>37</td><td>36</td><td></td><td>34</td><td></td><td></td><td></td></tr> <tr><td colspan="2">73</td><td>32</td><td>31</td><td>30</td><td>29</td><td>28</td><td>27</td><td></td><td>23</td><td></td><td></td><td>20</td><td>19</td><td>18</td><td>17</td><td></td><td></td><td></td></tr> <tr><td></td><td></td><td>16</td><td></td><td></td><td>13</td><td>12</td><td>11</td><td>10</td><td>9</td><td>7</td><td>6</td><td>4</td><td>3</td><td>1</td><td></td><td></td><td></td><td></td></tr> </table>	72	71		69	67	65	64	63			59	58	57	56							50	49	48	47				41			38	37	36		34				73		32	31	30	29	28	27		23			20	19	18	17						16			13	12	11	10	9	7	6	4	3	1					
72	71		69	67	65	64	63			59	58	57	56																																																																							
	50	49	48	47				41			38	37	36		34																																																																					
73		32	31	30	29	28	27		23			20	19	18	17																																																																					
		16			13	12	11	10	9	7	6	4	3	1																																																																						
AVAILABLE	NOT APPLICABLE	34566-1353	G	0	H	ST GRY	<table border="1"> <tr><td></td><td>79</td><td>78</td><td>77</td><td>76</td><td>75</td><td>74</td><td>73</td><td>72</td><td>71</td><td>70</td><td>69</td><td>68</td><td>66</td><td>65</td><td>64</td><td>63</td><td>61</td><td></td></tr> <tr><td>60</td><td>59</td><td>58</td><td>57</td><td>56</td><td></td><td></td><td>53</td><td></td><td>50</td><td></td><td></td><td></td><td></td><td>44</td><td>43</td><td>41</td><td></td><td></td></tr> <tr><td>40</td><td>39</td><td>38</td><td>37</td><td></td><td>35</td><td>34</td><td></td><td>32</td><td>30</td><td>29</td><td>27</td><td>26</td><td></td><td></td><td></td><td>22</td><td>21</td><td></td></tr> <tr><td>20</td><td>19</td><td>18</td><td>17</td><td></td><td></td><td></td><td>13</td><td>12</td><td>11</td><td></td><td>8</td><td>6</td><td>5</td><td>3</td><td>2</td><td></td><td></td><td></td></tr> </table>		79	78	77	76	75	74	73	72	71	70	69	68	66	65	64	63	61		60	59	58	57	56			53		50					44	43	41			40	39	38	37		35	34		32	30	29	27	26				22	21		20	19	18	17				13	12	11		8	6	5	3	2				
	79	78	77	76	75	74	73	72	71	70	69	68	66	65	64	63	61																																																																			
60	59	58	57	56			53		50					44	43	41																																																																				
40	39	38	37		35	34		32	30	29	27	26				22	21																																																																			
20	19	18	17				13	12	11		8	6	5	3	2																																																																					
AVAILABLE	NOT APPLICABLE	34566-1363	G	0	A	BLACK	<table border="1"> <tr><td>72</td><td>71</td><td></td><td>69</td><td>68</td><td>67</td><td>66</td><td>64</td><td>63</td><td>62</td><td></td><td>59</td><td></td><td></td><td></td><td></td><td></td><td></td><td>53</td></tr> <tr><td></td><td></td><td></td><td>48</td><td>46</td><td>44</td><td>43</td><td>42</td><td></td><td></td><td></td><td>39</td><td></td><td></td><td></td><td></td><td></td><td></td><td>33</td></tr> <tr><td colspan="2">73</td><td>32</td><td></td><td>29</td><td>27</td><td></td><td></td><td></td><td></td><td>24</td><td>23</td><td></td><td></td><td></td><td></td><td></td><td></td><td>17</td></tr> <tr><td></td><td></td><td></td><td></td><td>14</td><td>13</td><td>12</td><td>11</td><td>9</td><td>8</td><td></td><td></td><td>5</td><td>4</td><td>3</td><td>2</td><td>1</td><td></td><td></td></tr> </table>	72	71		69	68	67	66	64	63	62		59							53				48	46	44	43	42				39							33	73		32		29	27					24	23							17					14	13	12	11	9	8			5	4	3	2	1			
72	71		69	68	67	66	64	63	62		59							53																																																																		
			48	46	44	43	42				39							33																																																																		
73		32		29	27					24	23							17																																																																		
				14	13	12	11	9	8			5	4	3	2	1																																																																				

ENTER DESCRIPTION IEC NO: UAU2014-0574 DRAWN BY: SKRAJENDRANA 2013/10/08 CHKD: APPR: IKOSHIY 2013/10/09 GO	QUALITY SYMBOLS ▽=0 ▽=0 ▽=0	GENERAL TOLERANCES (UNLESS SPECIFIED) <table border="1"> <tr><th></th><th>mm</th><th>INCH</th></tr> <tr><td>4 PLACES</td><td>±---</td><td>±---</td></tr> <tr><td>3 PLACES</td><td>±---</td><td>±---</td></tr> <tr><td>2 PLACES</td><td>±---</td><td>±---</td></tr> <tr><td>1 PLACE</td><td>±---</td><td>±---</td></tr> <tr><td>0 PLACE</td><td>±---</td><td>±---</td></tr> </table>		mm	INCH	4 PLACES	±---	±---	3 PLACES	±---	±---	2 PLACES	±---	±---	1 PLACE	±---	±---	0 PLACE	±---	±---	DIMENSION STYLE MM ONLY	SCALE DESIGN UNITS METRIC	THIRD ANGLE PROJECTION
		mm	INCH																				
	4 PLACES	±---	±---																				
	3 PLACES	±---	±---																				
2 PLACES	±---	±---																					
1 PLACE	±---	±---																					
0 PLACE	±---	±---																					
ANGULAR ±--- DRAFT WHERE APPLICABLE MUST REMAIN WITHIN DIMENSIONS	DRAWN BY SKRAJENDRANA 2011/02/14 DATE	CHECKED BY MVANSLAMBROU 2011/02/14 DATE	TITLE MX123 66/73/80CKT HRNS CONN ASSY	MATERIAL NO. SD-34566-001	DOCUMENT NO. SD-34566-001																		
SEE BOM TABLE	APPROVED BY DATE	SIZE D	THIS DRAWING CONTAINS INFORMATION THAT IS PROPRIETARY TO MOLEX INCORPORATED AND SHOULD NOT BE USED WITHOUT WRITTEN PERMISSION	SHEET NO. 18 OF 68																			

STATUS	GM PART #	MATERIAL #	PART/MATERIAL REVISION	WIRE DRESS OPTION	KEY OPTION	COLOR (TPA)	NUMBERS INDICATE CAVITIES OPEN FOR CIRCUITS																																																																			
AVAILABLE	NOT APPLICABLE	34566-1473	G	0	A	BLACK	<table border="1"> <tr><td>72</td><td>71</td><td>69</td><td>68</td><td>67</td><td>66</td><td>64</td><td>63</td><td>62</td><td>59</td><td>58</td><td>56</td><td>54</td><td>53</td></tr> <tr><td>52</td><td></td><td>49</td><td>48</td><td>46</td><td>44</td><td>43</td><td>42</td><td></td><td>39</td><td></td><td></td><td>34</td><td>33</td></tr> <tr><td></td><td>73</td><td></td><td>32</td><td></td><td>29</td><td>27</td><td></td><td>24</td><td>23</td><td></td><td></td><td></td><td>17</td></tr> <tr><td></td><td></td><td></td><td></td><td>14</td><td>13</td><td>12</td><td>11</td><td>9</td><td>8</td><td>7</td><td>6</td><td>5</td><td>4</td><td>3</td><td>2</td><td>1</td></tr> </table>	72	71	69	68	67	66	64	63	62	59	58	56	54	53	52		49	48	46	44	43	42		39			34	33		73		32		29	27		24	23				17					14	13	12	11	9	8	7	6	5	4	3	2	1								
72	71	69	68	67	66	64	63	62	59	58	56	54	53																																																													
52		49	48	46	44	43	42		39			34	33																																																													
	73		32		29	27		24	23				17																																																													
				14	13	12	11	9	8	7	6	5	4	3	2	1																																																										
AVAILABLE	NOT APPLICABLE	34566-1483	G	0	A	BLACK	<table border="1"> <tr><td>72</td><td>71</td><td>69</td><td>68</td><td></td><td>65</td><td>64</td><td>63</td><td>61</td><td>59</td><td>58</td><td>56</td><td></td><td></td></tr> <tr><td>52</td><td></td><td>50</td><td>49</td><td>47</td><td></td><td></td><td></td><td>41</td><td></td><td></td><td>38</td><td>37</td><td>34</td><td>33</td></tr> <tr><td></td><td>73</td><td></td><td>32</td><td>31</td><td>30</td><td>29</td><td>28</td><td>27</td><td></td><td>24</td><td>23</td><td></td><td>20</td><td>19</td><td>18</td><td>17</td></tr> <tr><td></td><td></td><td></td><td>16</td><td></td><td></td><td>13</td><td>12</td><td>11</td><td>10</td><td>9</td><td></td><td></td><td></td><td></td><td></td><td>1</td></tr> </table>	72	71	69	68		65	64	63	61	59	58	56			52		50	49	47				41			38	37	34	33		73		32	31	30	29	28	27		24	23		20	19	18	17				16			13	12	11	10	9						1				
72	71	69	68		65	64	63	61	59	58	56																																																															
52		50	49	47				41			38	37	34	33																																																												
	73		32	31	30	29	28	27		24	23		20	19	18	17																																																										
			16			13	12	11	10	9						1																																																										
AVAILABLE	NOT APPLICABLE	34566-1493	G	0	B	ST GRAY	<table border="1"> <tr><td></td><td></td><td></td><td>68</td><td></td><td></td><td></td><td></td><td></td><td>59</td><td>58</td><td>57</td><td>55</td><td>53</td></tr> <tr><td></td><td></td><td>49</td><td>48</td><td>46</td><td></td><td></td><td></td><td></td><td>39</td><td>38</td><td>37</td><td>35</td><td>33</td></tr> <tr><td></td><td>73</td><td></td><td></td><td></td><td>29</td><td></td><td></td><td></td><td>23</td><td>22</td><td>21</td><td></td><td>18</td><td>17</td></tr> <tr><td></td><td></td><td></td><td></td><td></td><td>12</td><td>11</td><td>10</td><td></td><td>7</td><td></td><td></td><td></td><td></td><td></td><td></td><td>1</td></tr> </table>				68						59	58	57	55	53			49	48	46					39	38	37	35	33		73				29				23	22	21		18	17						12	11	10		7							1							
			68						59	58	57	55	53																																																													
		49	48	46					39	38	37	35	33																																																													
	73				29				23	22	21		18	17																																																												
					12	11	10		7							1																																																										
AVAILABLE	NOT APPLICABLE	34566-1513	G	0	B	ST GRAY	<table border="1"> <tr><td></td><td></td><td></td><td></td><td></td><td>65</td><td></td><td></td><td></td><td>59</td><td>57</td><td>55</td><td>53</td></tr> <tr><td></td><td></td><td>49</td><td>48</td><td>46</td><td></td><td></td><td></td><td></td><td>39</td><td>37</td><td>35</td><td>33</td></tr> <tr><td></td><td>73</td><td></td><td></td><td></td><td>29</td><td></td><td></td><td></td><td>23</td><td>21</td><td></td><td>17</td></tr> <tr><td></td><td></td><td></td><td></td><td></td><td>12</td><td></td><td></td><td></td><td>7</td><td></td><td></td><td></td><td></td><td></td><td></td><td></td></tr> </table>						65				59	57	55	53			49	48	46					39	37	35	33		73				29				23	21		17						12				7																		
					65				59	57	55	53																																																														
		49	48	46					39	37	35	33																																																														
	73				29				23	21		17																																																														
					12				7																																																																	
AVAILABLE	NOT APPLICABLE	34566-1523	G	0	A	BLACK	<table border="1"> <tr><td></td><td>70</td><td>69</td><td>68</td><td></td><td>65</td><td>64</td><td></td><td></td><td>59</td><td>58</td><td>56</td><td>54</td></tr> <tr><td>52</td><td>50</td><td>49</td><td>47</td><td></td><td></td><td></td><td>42</td><td>41</td><td></td><td></td><td>38</td><td>37</td><td>36</td><td>34</td></tr> <tr><td></td><td>73</td><td></td><td>32</td><td>31</td><td>30</td><td>29</td><td>28</td><td>27</td><td>26</td><td></td><td>23</td><td></td><td>20</td><td>19</td><td>18</td><td>17</td></tr> <tr><td></td><td></td><td></td><td>16</td><td></td><td></td><td>13</td><td>12</td><td>11</td><td>10</td><td>9</td><td>8</td><td></td><td></td><td></td><td></td><td>1</td></tr> </table>		70	69	68		65	64			59	58	56	54	52	50	49	47				42	41			38	37	36	34		73		32	31	30	29	28	27	26		23		20	19	18	17				16			13	12	11	10	9	8					1					
	70	69	68		65	64			59	58	56	54																																																														
52	50	49	47				42	41			38	37	36	34																																																												
	73		32	31	30	29	28	27	26		23		20	19	18	17																																																										
			16			13	12	11	10	9	8					1																																																										
AVAILABLE	NOT APPLICABLE	34566-1533	G	0	A	BLACK	<table border="1"> <tr><td>72</td><td>71</td><td>70</td><td>69</td><td>68</td><td></td><td>65</td><td>64</td><td>63</td><td>61</td><td>59</td><td>58</td><td>57</td><td>56</td><td></td><td></td></tr> <tr><td>52</td><td>51</td><td>50</td><td>49</td><td>47</td><td></td><td></td><td></td><td></td><td>41</td><td></td><td></td><td>38</td><td>37</td><td>36</td><td>34</td><td>33</td></tr> <tr><td></td><td>73</td><td></td><td>32</td><td>31</td><td>30</td><td>29</td><td>28</td><td>27</td><td></td><td>24</td><td>23</td><td></td><td>20</td><td>19</td><td>18</td><td>17</td></tr> <tr><td></td><td></td><td></td><td>16</td><td></td><td></td><td>13</td><td>12</td><td>11</td><td>10</td><td>9</td><td></td><td></td><td></td><td>3</td><td>2</td><td>1</td></tr> </table>	72	71	70	69	68		65	64	63	61	59	58	57	56			52	51	50	49	47					41			38	37	36	34	33		73		32	31	30	29	28	27		24	23		20	19	18	17				16			13	12	11	10	9				3	2	1
72	71	70	69	68		65	64	63	61	59	58	57	56																																																													
52	51	50	49	47					41			38	37	36	34	33																																																										
	73		32	31	30	29	28	27		24	23		20	19	18	17																																																										
			16			13	12	11	10	9				3	2	1																																																										
AVAILABLE	NOT APPLICABLE	34566-1543	G	0	B	ST GRAY	<table border="1"> <tr><td></td><td></td><td>69</td><td>68</td><td>66</td><td></td><td></td><td></td><td></td><td>59</td><td>57</td><td>55</td><td>53</td></tr> <tr><td></td><td></td><td>49</td><td>48</td><td>46</td><td></td><td></td><td></td><td></td><td>39</td><td>37</td><td>35</td><td>33</td></tr> <tr><td></td><td>73</td><td></td><td></td><td></td><td>29</td><td></td><td></td><td></td><td>23</td><td>21</td><td></td><td></td></tr> <tr><td></td><td></td><td></td><td></td><td></td><td></td><td>11</td><td>10</td><td></td><td>7</td><td></td><td></td><td></td><td></td><td></td><td></td><td></td></tr> </table>			69	68	66					59	57	55	53			49	48	46					39	37	35	33		73				29				23	21									11	10		7																		
		69	68	66					59	57	55	53																																																														
		49	48	46					39	37	35	33																																																														
	73				29				23	21																																																																
						11	10		7																																																																	
AVAILABLE	NOT APPLICABLE	34566-1583	G	0	A	BLACK	<table border="1"> <tr><td></td><td>70</td><td></td><td>67</td><td>66</td><td>65</td><td></td><td>61</td><td></td><td></td><td>58</td><td>57</td><td>55</td><td>54</td></tr> <tr><td></td><td>49</td><td></td><td>47</td><td>45</td><td>44</td><td>43</td><td>42</td><td>41</td><td>39</td><td>37</td><td></td><td>34</td></tr> <tr><td></td><td>73</td><td></td><td>32</td><td>30</td><td></td><td>27</td><td>25</td><td>24</td><td></td><td>21</td><td>20</td><td>19</td><td>18</td><td>17</td></tr> <tr><td></td><td></td><td></td><td>15</td><td>13</td><td>11</td><td>9</td><td>8</td><td></td><td>6</td><td>5</td><td></td><td>3</td><td>2</td><td>1</td></tr> </table>		70		67	66	65		61			58	57	55	54		49		47	45	44	43	42	41	39	37		34		73		32	30		27	25	24		21	20	19	18	17				15	13	11	9	8		6	5		3	2	1										
	70		67	66	65		61			58	57	55	54																																																													
	49		47	45	44	43	42	41	39	37		34																																																														
	73		32	30		27	25	24		21	20	19	18	17																																																												
			15	13	11	9	8		6	5		3	2	1																																																												

ENTER DESCRIPTION IEC NO: UAU2014-0574 DRAWNS: SKRAJENDRANA 2013/10/08 CHYD: APPR: IKOSHY 2013/10/09 REV:	QUALITY SYMBOLS	GENERAL TOLERANCES (UNLESS SPECIFIED)	DIMENSION STYLE	SCALE	DESIGN UNITS	THIRD ANGLE PROJECTION
	▽=0	mm INCH	MM ONLY		METRIC	
	▽=0	4 PLACES ± --- ± ---	DRAWN BY DATE	TITLE		
	▽=0	3 PLACES ± --- ± ---	SKRAJENDRANA 2011/02/14	MX123		
▽=0	2 PLACES ± --- ± ---	CHECKED BY DATE	66/73/80CKT			
▽=0	1 PLACE ± --- ± ---	MYANSLAMBROU 2011/02/14	HRNS CONN ASSY			
▽=0	0 PLACE ± --- ± ---	APPROVED BY DATE	molex			
	ANGULAR ± ---°	MATERIAL NO.	DOCUMENT NO.		SHEET NO.	
	DRAFT WHERE APPLICABLE MUST REMAIN WITHIN DIMENSIONS	SEE BOM TABLE	SD-34566-001		20 OF 68	
		THIS DRAWING CONTAINS INFORMATION THAT IS PROPRIETARY TO MOLEX INCORPORATED AND SHOULD NOT BE USED WITHOUT WRITTEN PERMISSION				

20 19 18 17 16 15 14 13 12 11 10 9 8 7 6 5 4 3 2 1

STATUS	GM PART #	MATERIAL #	PART/MATERIAL REVISION	WIRE DRESS OPTION	KEY OPTION	COLOR (TPA)	NUMBERS INDICATE CAVITIES OPEN FOR CIRCUITS																																																																								
AVAILABLE	NOT APPLICABLE	34566-1693	G	0	B	ST GRAY	<table border="1"> <tr><td></td><td></td><td></td><td></td><td>66</td><td>64</td><td></td><td></td><td></td><td></td><td>59</td><td>57</td><td>55</td><td>53</td></tr> <tr><td></td><td></td><td>49</td><td>48</td><td>46</td><td></td><td></td><td></td><td></td><td></td><td>39</td><td>37</td><td>35</td><td>33</td></tr> <tr><td>73</td><td></td><td>32</td><td></td><td>29</td><td></td><td></td><td></td><td></td><td></td><td>23</td><td>21</td><td></td><td>17</td></tr> <tr><td></td><td></td><td></td><td></td><td></td><td>12</td><td></td><td></td><td></td><td></td><td>7</td><td></td><td></td><td></td></tr> </table>					66	64					59	57	55	53			49	48	46						39	37	35	33	73		32		29						23	21		17						12					7																			
				66	64					59	57	55	53																																																																		
		49	48	46						39	37	35	33																																																																		
73		32		29						23	21		17																																																																		
					12					7																																																																					
AVAILABLE	NOT APPLICABLE	34566-1713	G	0	B	ST GRAY	<table border="1"> <tr><td>71</td><td>70</td><td>68</td><td>66</td><td>65</td><td>64</td><td>63</td><td></td><td></td><td>60</td><td>59</td><td>58</td><td>57</td><td>56</td><td>55</td><td>54</td><td>53</td></tr> <tr><td>51</td><td>50</td><td>49</td><td>48</td><td>46</td><td>45</td><td>43</td><td></td><td>41</td><td>40</td><td>39</td><td>38</td><td>37</td><td>36</td><td>35</td><td>33</td><td></td></tr> <tr><td>73</td><td></td><td>32</td><td>31</td><td>30</td><td></td><td></td><td></td><td></td><td>24</td><td>23</td><td>22</td><td></td><td>20</td><td>19</td><td></td><td></td></tr> <tr><td></td><td></td><td>16</td><td>15</td><td></td><td>13</td><td>12</td><td>11</td><td>10</td><td>9</td><td>8</td><td>7</td><td>6</td><td>5</td><td>4</td><td>3</td><td>2</td></tr> </table>	71	70	68	66	65	64	63			60	59	58	57	56	55	54	53	51	50	49	48	46	45	43		41	40	39	38	37	36	35	33		73		32	31	30					24	23	22		20	19					16	15		13	12	11	10	9	8	7	6	5	4	3	2				
71	70	68	66	65	64	63			60	59	58	57	56	55	54	53																																																															
51	50	49	48	46	45	43		41	40	39	38	37	36	35	33																																																																
73		32	31	30					24	23	22		20	19																																																																	
		16	15		13	12	11	10	9	8	7	6	5	4	3	2																																																															
AVAILABLE	NOT APPLICABLE	34566-1723	G	0	B	ST GRAY	<table border="1"> <tr><td>71</td><td>70</td><td>68</td><td>66</td><td>65</td><td></td><td></td><td></td><td></td><td>60</td><td>59</td><td>58</td><td>57</td><td></td><td></td><td>54</td><td>53</td></tr> <tr><td>51</td><td>50</td><td>49</td><td>48</td><td>46</td><td>45</td><td>43</td><td></td><td>41</td><td>40</td><td>39</td><td>38</td><td>37</td><td>36</td><td>35</td><td>33</td><td></td></tr> <tr><td>73</td><td></td><td>32</td><td>31</td><td>30</td><td></td><td></td><td></td><td></td><td>24</td><td>23</td><td>22</td><td></td><td>20</td><td></td><td></td><td></td></tr> <tr><td></td><td></td><td>16</td><td>15</td><td></td><td>13</td><td>12</td><td>11</td><td>10</td><td>9</td><td>8</td><td>7</td><td>6</td><td>5</td><td>4</td><td></td><td></td></tr> </table>	71	70	68	66	65					60	59	58	57			54	53	51	50	49	48	46	45	43		41	40	39	38	37	36	35	33		73		32	31	30					24	23	22		20						16	15		13	12	11	10	9	8	7	6	5	4						
71	70	68	66	65					60	59	58	57			54	53																																																															
51	50	49	48	46	45	43		41	40	39	38	37	36	35	33																																																																
73		32	31	30					24	23	22		20																																																																		
		16	15		13	12	11	10	9	8	7	6	5	4																																																																	
AVAILABLE	NOT APPLICABLE	34566-1733	G	0	A	BLACK	<table border="1"> <tr><td></td><td>70</td><td>68</td><td>67</td><td>66</td><td>65</td><td></td><td></td><td></td><td></td><td></td><td>58</td><td>57</td><td>55</td><td></td><td></td><td></td></tr> <tr><td></td><td>49</td><td></td><td>47</td><td></td><td></td><td>44</td><td>43</td><td>42</td><td>41</td><td></td><td>39</td><td></td><td>37</td><td>35</td><td></td><td></td></tr> <tr><td>73</td><td></td><td>32</td><td></td><td>30</td><td></td><td></td><td></td><td>27</td><td>25</td><td>24</td><td></td><td></td><td>21</td><td>20</td><td>19</td><td>18</td><td>17</td></tr> <tr><td></td><td></td><td>16</td><td>15</td><td></td><td>13</td><td></td><td></td><td>10</td><td>9</td><td>8</td><td></td><td>6</td><td>5</td><td></td><td>3</td><td>2</td><td>1</td></tr> </table>		70	68	67	66	65						58	57	55					49		47			44	43	42	41		39		37	35			73		32		30				27	25	24			21	20	19	18	17			16	15		13			10	9	8		6	5		3	2	1		
	70	68	67	66	65						58	57	55																																																																		
	49		47			44	43	42	41		39		37	35																																																																	
73		32		30				27	25	24			21	20	19	18	17																																																														
		16	15		13			10	9	8		6	5		3	2	1																																																														
AVAILABLE	NOT APPLICABLE	34566-1743	G	0	A	BLACK	<table border="1"> <tr><td></td><td>70</td><td></td><td>67</td><td>66</td><td>65</td><td></td><td></td><td></td><td></td><td></td><td></td><td>58</td><td>57</td><td>55</td><td></td><td></td><td></td></tr> <tr><td></td><td>49</td><td></td><td>47</td><td></td><td></td><td>44</td><td>43</td><td>42</td><td>41</td><td></td><td>39</td><td></td><td>37</td><td>35</td><td></td><td></td><td></td></tr> <tr><td>73</td><td></td><td>32</td><td></td><td>30</td><td></td><td></td><td></td><td>27</td><td>25</td><td>24</td><td></td><td></td><td>21</td><td>20</td><td>19</td><td>18</td><td>17</td></tr> <tr><td></td><td></td><td>16</td><td>15</td><td></td><td>13</td><td></td><td></td><td>10</td><td>9</td><td>8</td><td></td><td>6</td><td>5</td><td></td><td>3</td><td>2</td><td>1</td></tr> </table>		70		67	66	65							58	57	55					49		47			44	43	42	41		39		37	35				73		32		30				27	25	24			21	20	19	18	17			16	15		13			10	9	8		6	5		3	2	1
	70		67	66	65							58	57	55																																																																	
	49		47			44	43	42	41		39		37	35																																																																	
73		32		30				27	25	24			21	20	19	18	17																																																														
		16	15		13			10	9	8		6	5		3	2	1																																																														
AVAILABLE	NOT APPLICABLE	34566-1753	G	0	A	BLACK	<table border="1"> <tr><td></td><td>70</td><td></td><td>67</td><td>66</td><td>65</td><td></td><td></td><td></td><td></td><td></td><td></td><td>58</td><td>57</td><td>55</td><td></td><td></td><td></td></tr> <tr><td></td><td>49</td><td></td><td>47</td><td></td><td></td><td>44</td><td>43</td><td>42</td><td>41</td><td></td><td>39</td><td></td><td>37</td><td>35</td><td></td><td></td><td></td></tr> <tr><td>73</td><td></td><td>32</td><td></td><td></td><td></td><td></td><td></td><td>27</td><td>25</td><td>24</td><td></td><td></td><td>21</td><td>20</td><td>19</td><td>18</td><td>17</td></tr> <tr><td></td><td></td><td></td><td>15</td><td></td><td>13</td><td></td><td></td><td></td><td>9</td><td>8</td><td></td><td>6</td><td>5</td><td></td><td>3</td><td></td><td>1</td></tr> </table>		70		67	66	65							58	57	55					49		47			44	43	42	41		39		37	35				73		32						27	25	24			21	20	19	18	17				15		13				9	8		6	5		3		1
	70		67	66	65							58	57	55																																																																	
	49		47			44	43	42	41		39		37	35																																																																	
73		32						27	25	24			21	20	19	18	17																																																														
			15		13				9	8		6	5		3		1																																																														
AVAILABLE	NOT APPLICABLE	34566-1763	G	0	B	ST GRAY	<table border="1"> <tr><td></td><td></td><td></td><td>67</td><td>65</td><td></td><td></td><td></td><td></td><td>61</td><td>60</td><td>59</td><td>58</td><td>57</td><td></td><td></td><td>54</td><td>53</td></tr> <tr><td>51</td><td>50</td><td>49</td><td>48</td><td>47</td><td>46</td><td>45</td><td>43</td><td></td><td></td><td>40</td><td>39</td><td></td><td>37</td><td></td><td></td><td>34</td><td>33</td></tr> <tr><td>73</td><td></td><td></td><td>32</td><td>31</td><td>30</td><td></td><td></td><td></td><td>26</td><td></td><td>24</td><td>23</td><td>22</td><td>21</td><td>20</td><td></td><td></td></tr> <tr><td></td><td></td><td></td><td>16</td><td>15</td><td>14</td><td>13</td><td></td><td></td><td>10</td><td>9</td><td>8</td><td>7</td><td>6</td><td>5</td><td>4</td><td></td><td></td></tr> </table>				67	65					61	60	59	58	57			54	53	51	50	49	48	47	46	45	43			40	39		37			34	33	73			32	31	30				26		24	23	22	21	20						16	15	14	13			10	9	8	7	6	5	4		
			67	65					61	60	59	58	57			54	53																																																														
51	50	49	48	47	46	45	43			40	39		37			34	33																																																														
73			32	31	30				26		24	23	22	21	20																																																																
			16	15	14	13			10	9	8	7	6	5	4																																																																

ENTER DESCRIPTION IEC NO: UAU2014-0574 DRAWNS: SKRAJENDRANA 2013/10/08 CHKD: APPR: IKOSHY 2013/10/09 REV:	QUALITY SYMBOLS ▽=0 ▽=0 ▽=0	GENERAL TOLERANCES (UNLESS SPECIFIED) <table border="1"> <tr><th></th><th>mm</th><th>INCH</th></tr> <tr><td>4 PLACES</td><td>±----</td><td>±----</td></tr> <tr><td>3 PLACES</td><td>±----</td><td>±----</td></tr> <tr><td>2 PLACES</td><td>±----</td><td>±----</td></tr> <tr><td>1 PLACE</td><td>±----</td><td>±----</td></tr> <tr><td>0 PLACE</td><td>±----</td><td>±----</td></tr> </table>		mm	INCH	4 PLACES	±----	±----	3 PLACES	±----	±----	2 PLACES	±----	±----	1 PLACE	±----	±----	0 PLACE	±----	±----	DIMENSION STYLE MM ONLY	SCALE DESIGN UNITS METRIC	THIRD ANGLE PROJECTION
		mm	INCH																				
	4 PLACES	±----	±----																				
	3 PLACES	±----	±----																				
2 PLACES	±----	±----																					
1 PLACE	±----	±----																					
0 PLACE	±----	±----																					
		ANGULAR ±---- DRAFT WHERE APPLICABLE MUST REMAIN WITHIN DIMENSIONS	DRAWN BY SKRAJENDRANA 2011/02/14 CHECKED BY MVANSLAMBROU 2011/02/14 APPROVED BY	TITLE MX123 66/73/80CKT HRNS CONN ASSY molex																			
			MATERIAL NO. SEE BOM TABLE	DOCUMENT NO. SD-34566-001	SHEET NO. 22 OF 68																		
			THIS DRAWING CONTAINS INFORMATION THAT IS PROPRIETARY TO MOLEX INCORPORATED AND SHOULD NOT BE USED WITHOUT WRITTEN PERMISSION																				

19 18 17 16 15 14 13 12 11 10 9 8 7 6 5 4 3 2 1

STATUS	GM PART #	MATERIAL #	PART/MATERIAL REVISION	WIRE DRESS OPTION	KEY OPTION	COLOR (TFA)	NUMBERS INDICATE CAVITIES OPEN FOR CIRCUITS															
AVAILABLE	NOT APPLICABLE	34566-1873	G	0	C	BLUE	72	70		67	66		63	62		59	57		53			
							52	51			46	44	42	40	39				34	33		
							73		32	30		27	26	25		22	21	20				
									15	14			10	9		6	5	4				
AVAILABLE	NOT APPLICABLE	34566-1883	G	0	A	BLACK		70		68	67	66	65					58	57	55		
								49		47		44	43	42	41	40	39		37	35		
							73		32	30		27	25	24		21	20	19	18	17		
									16	15	13		10	9	8	6	5	3	2	1		
AVAILABLE	NOT APPLICABLE	34566-1893	G	0	C	BLUE	72	70		66		63			59	57					53	
							52	51		46	44	42	40	39						34	33	
							73		32	30		27	26	25		22	21	20				
									15	14			10	9		6	5	4				
AVAILABLE	NOT APPLICABLE	34566-1913	G	0	B	ST GRAY	72	70	68	66				60	59				55	54	53	
							52	50	48	46				40	39				35	34	33	
							73		32	31	30	29	28	27	26	25	24					
									16					10	9	8						
AVAILABLE	NOT APPLICABLE	34566-1923	G	0	A	BLACK			69				63					58	56	55	54	53
							52	51		49			44	43	42	41			36	35	34	33
							73		32			28	26						19	18		
									16			12	10						3			
AVAILABLE	NOT APPLICABLE	34566-1933	G	0	A	BLACK		70		67	66	65				58	57		55			
								49		47		44	43	42	41	40	39		37	35		
							73		32	30		27	25	24		21	20	19	18	17		
									16	15	13		10	9	8	6	5	3	2	1		
AVAILABLE	NOT APPLICABLE	34566-1943	G	0	A	BLACK		70		67	66	65				58	57		55			
							51	49		47		44	43	42	41	40	39		37	35		
							73		32	30		27	25	24		21	20	19	18	17		
									16	15	13		10	9	8	6	5	3	2	1		
AVAILABLE	NOT APPLICABLE	34566-1953	G	0	C	BLUE	72	70		66		63			59	57					53	
							52	51		48	47	46	44	42	40	39					34	33
							73			30		26	25		22	21	20					
									15	14			10	9		6	5	4				
AVAILABLE	NOT APPLICABLE	34566-1963	G	0	C	BLUE	72	70		66		63			59	57					53	
							52	51		46	44	42	40	39						34	33	
							73			30		26	25		22	21	20					
									15	14			10	9		6	5	4				

ENTER DESCRIPTION IEC NO: UAU2014-0574 DRAWN BY: SKRAJENDRANA 2013/10/08 CHKD: MVANSLAMBROU 2011/02/14 APPR: WOSHY 2013/10/09 REV: 00	QUALITY SYMBOLS ∇=0 ∇=0 ∇=0	GENERAL TOLERANCES (UNLESS SPECIFIED) mm INCH 4 PLACES ±---+--- 3 PLACES ±---+--- 2 PLACES ±---+--- 1 PLACE ±---+--- 0 PLACE ±---+---	DIMENSION STYLE MM ONLY	SCALE DESIGN UNITS METRIC	THIRD ANGLE PROJECTION	
	DRAWN BY: SKRAJENDRANA 2011/02/14 CHECKED BY: MVANSLAMBROU 2011/02/14 APPROVED BY:	DATE:	DATE:	DATE:	TITLE MX123 66/73/80CKT HRNS CONN ASSY	SHEET NO. 24 OF 68
	MATERIAL NO. SEE BOM TABLE	DOCUMENT NO. SD-34566-001	THIS DRAWING CONTAINS INFORMATION THAT IS PROPRIETARY TO MOLEX INCORPORATED AND SHOULD NOT BE USED WITHOUT WRITTEN PERMISSION			
	SIZE D					

STATUS	GM PART #	MATERIAL #	PART/MATERIAL REVISION	WIRE DRESS OPTION	KEY OPTION	COLOR (TPA)	NUMBERS INDICATE CAVITIES OPEN FOR CIRCUITS																																																																																		
AVAILABLE	NOT APPLICABLE	34566-1973	G	0	A	BLACK	<table border="1"> <tr><td></td><td></td><td>69</td><td></td><td></td><td></td><td>63</td><td></td><td></td><td></td><td></td><td></td><td>56</td><td>55</td><td>54</td><td>53</td></tr> <tr><td>52</td><td>51</td><td>49</td><td></td><td></td><td></td><td>44</td><td>43</td><td>42</td><td>41</td><td></td><td></td><td></td><td>36</td><td>35</td><td>34</td><td>33</td></tr> <tr><td></td><td></td><td>73</td><td></td><td>32</td><td></td><td>28</td><td>26</td><td></td><td>23</td><td></td><td>21</td><td>19</td><td>18</td><td></td><td></td></tr> <tr><td></td><td></td><td></td><td></td><td>16</td><td></td><td>12</td><td>10</td><td>8</td><td></td><td>5</td><td>3</td><td></td><td></td><td></td><td></td></tr> </table>			69				63						56	55	54	53	52	51	49				44	43	42	41				36	35	34	33			73		32		28	26		23		21	19	18							16		12	10	8		5	3																					
		69				63						56	55	54	53																																																																										
52	51	49				44	43	42	41				36	35	34	33																																																																									
		73		32		28	26		23		21	19	18																																																																												
				16		12	10	8		5	3																																																																														
AVAILABLE	NOT APPLICABLE	34566-2013	G	0	A	BLACK	<table border="1"> <tr><td></td><td>71</td><td>70</td><td></td><td></td><td></td><td>65</td><td></td><td></td><td></td><td></td><td>60</td><td>59</td><td>58</td><td>57</td><td></td><td>54</td><td>53</td></tr> <tr><td></td><td>51</td><td>50</td><td>49</td><td>48</td><td>46</td><td>45</td><td>43</td><td>41</td><td>40</td><td>39</td><td></td><td>37</td><td>36</td><td>35</td><td></td><td>33</td><td></td></tr> <tr><td></td><td></td><td></td><td>73</td><td></td><td>32</td><td>31</td><td>30</td><td></td><td></td><td></td><td>24</td><td>23</td><td>22</td><td></td><td>20</td><td></td><td></td></tr> <tr><td></td><td></td><td></td><td></td><td></td><td>16</td><td>15</td><td>13</td><td>12</td><td>11</td><td>10</td><td>9</td><td>8</td><td>7</td><td>6</td><td>5</td><td>4</td><td></td></tr> </table>		71	70				65					60	59	58	57		54	53		51	50	49	48	46	45	43	41	40	39		37	36	35		33					73		32	31	30				24	23	22		20								16	15	13	12	11	10	9	8	7	6	5	4											
	71	70				65					60	59	58	57		54	53																																																																								
	51	50	49	48	46	45	43	41	40	39		37	36	35		33																																																																									
			73		32	31	30				24	23	22		20																																																																										
					16	15	13	12	11	10	9	8	7	6	5	4																																																																									
AVAILABLE	NOT APPLICABLE	34566-2023	G	0	A	BLACK	<table border="1"> <tr><td></td><td></td><td>70</td><td>68</td><td>67</td><td>66</td><td>65</td><td></td><td></td><td></td><td></td><td></td><td></td><td>58</td><td>57</td><td></td><td>55</td><td></td></tr> <tr><td></td><td></td><td></td><td>49</td><td></td><td>47</td><td></td><td>44</td><td>43</td><td>42</td><td>41</td><td></td><td>39</td><td></td><td>37</td><td></td><td>35</td><td></td></tr> <tr><td></td><td></td><td></td><td></td><td>73</td><td></td><td>32</td><td></td><td>30</td><td></td><td></td><td>27</td><td>25</td><td>24</td><td></td><td>21</td><td>20</td><td>19</td><td>18</td><td>17</td></tr> <tr><td></td><td></td><td></td><td></td><td></td><td></td><td>15</td><td></td><td>13</td><td></td><td></td><td>9</td><td>8</td><td></td><td>6</td><td>5</td><td></td><td>3</td><td></td><td>1</td></tr> </table>			70	68	67	66	65							58	57		55					49		47		44	43	42	41		39		37		35						73		32		30			27	25	24		21	20	19	18	17							15		13			9	8		6	5		3		1						
		70	68	67	66	65							58	57		55																																																																									
			49		47		44	43	42	41		39		37		35																																																																									
				73		32		30			27	25	24		21	20	19	18	17																																																																						
						15		13			9	8		6	5		3		1																																																																						
AVAILABLE	NOT APPLICABLE	34566-2033	G	0	A	BLACK	<table border="1"> <tr><td></td><td>71</td><td>70</td><td></td><td></td><td></td><td>65</td><td>64</td><td></td><td></td><td></td><td>60</td><td>59</td><td>58</td><td>57</td><td></td><td>55</td><td>54</td><td>53</td></tr> <tr><td></td><td>51</td><td>50</td><td>49</td><td>48</td><td>46</td><td>45</td><td>43</td><td>41</td><td>40</td><td>39</td><td></td><td>37</td><td>36</td><td>35</td><td></td><td>33</td><td></td><td></td></tr> <tr><td></td><td></td><td></td><td>73</td><td></td><td>32</td><td>31</td><td>30</td><td></td><td></td><td></td><td>24</td><td>23</td><td>22</td><td></td><td>20</td><td></td><td></td><td></td></tr> <tr><td></td><td></td><td></td><td></td><td></td><td>16</td><td>15</td><td>13</td><td>12</td><td>11</td><td>10</td><td>9</td><td>8</td><td>7</td><td>6</td><td>5</td><td>4</td><td>3</td><td>2</td><td>1</td></tr> </table>		71	70				65	64				60	59	58	57		55	54	53		51	50	49	48	46	45	43	41	40	39		37	36	35		33						73		32	31	30				24	23	22		20									16	15	13	12	11	10	9	8	7	6	5	4	3	2	1					
	71	70				65	64				60	59	58	57		55	54	53																																																																							
	51	50	49	48	46	45	43	41	40	39		37	36	35		33																																																																									
			73		32	31	30				24	23	22		20																																																																										
					16	15	13	12	11	10	9	8	7	6	5	4	3	2	1																																																																						
AVAILABLE	NOT APPLICABLE	34566-2043	G	0	A	BLACK	<table border="1"> <tr><td></td><td></td><td>70</td><td></td><td>67</td><td>66</td><td>65</td><td></td><td></td><td></td><td></td><td></td><td></td><td>58</td><td>57</td><td></td><td>55</td><td></td><td></td></tr> <tr><td></td><td></td><td></td><td>49</td><td></td><td>47</td><td></td><td>44</td><td>43</td><td>42</td><td>41</td><td></td><td>39</td><td></td><td>37</td><td></td><td>35</td><td></td><td></td></tr> <tr><td></td><td></td><td></td><td></td><td>73</td><td></td><td>32</td><td></td><td>30</td><td></td><td></td><td>27</td><td>25</td><td>24</td><td></td><td>21</td><td>20</td><td>19</td><td>18</td><td>17</td></tr> <tr><td></td><td></td><td></td><td></td><td></td><td></td><td>15</td><td></td><td>13</td><td></td><td></td><td>9</td><td>8</td><td></td><td>6</td><td>5</td><td></td><td>3</td><td></td><td>1</td></tr> </table>			70		67	66	65							58	57		55						49		47		44	43	42	41		39		37		35							73		32		30			27	25	24		21	20	19	18	17							15		13			9	8		6	5		3		1				
		70		67	66	65							58	57		55																																																																									
			49		47		44	43	42	41		39		37		35																																																																									
				73		32		30			27	25	24		21	20	19	18	17																																																																						
						15		13			9	8		6	5		3		1																																																																						
AVAILABLE	NOT APPLICABLE	34566-2053	G	0	B	ST GRAY	<table border="1"> <tr><td></td><td></td><td>70</td><td></td><td>68</td><td>67</td><td>66</td><td>65</td><td></td><td></td><td></td><td></td><td></td><td>58</td><td>57</td><td></td><td>55</td><td></td><td></td></tr> <tr><td></td><td></td><td></td><td>49</td><td></td><td>47</td><td></td><td>44</td><td>43</td><td>42</td><td>41</td><td></td><td>39</td><td></td><td>37</td><td></td><td>35</td><td></td><td></td></tr> <tr><td></td><td></td><td></td><td></td><td>73</td><td></td><td>32</td><td></td><td>30</td><td></td><td></td><td>27</td><td>25</td><td>24</td><td>23</td><td>21</td><td>20</td><td>19</td><td>18</td><td>17</td></tr> <tr><td></td><td></td><td></td><td></td><td></td><td></td><td></td><td></td><td>13</td><td></td><td></td><td>8</td><td></td><td>6</td><td>5</td><td></td><td>3</td><td></td><td>1</td><td></td></tr> </table>			70		68	67	66	65						58	57		55						49		47		44	43	42	41		39		37		35							73		32		30			27	25	24	23	21	20	19	18	17									13			8		6	5		3		1					
		70		68	67	66	65						58	57		55																																																																									
			49		47		44	43	42	41		39		37		35																																																																									
				73		32		30			27	25	24	23	21	20	19	18	17																																																																						
								13			8		6	5		3		1																																																																							
AVAILABLE	NOT APPLICABLE	34566-2063	G	0	H	ST GRAY	<table border="1"> <tr><td></td><td></td><td></td><td>78</td><td></td><td></td><td></td><td></td><td></td><td>72</td><td>71</td><td>70</td><td>69</td><td>68</td><td></td><td>66</td><td>65</td><td>64</td><td>63</td><td>61</td></tr> <tr><td></td><td></td><td></td><td>58</td><td>57</td><td>56</td><td></td><td></td><td>53</td><td>52</td><td>51</td><td>50</td><td></td><td></td><td></td><td></td><td></td><td>44</td><td>43</td><td>41</td></tr> <tr><td></td><td></td><td></td><td>40</td><td></td><td>37</td><td>35</td><td>34</td><td></td><td>32</td><td>30</td><td>29</td><td></td><td>27</td><td>26</td><td></td><td></td><td></td><td></td><td>22</td><td>21</td></tr> <tr><td></td><td></td><td></td><td>20</td><td>19</td><td>18</td><td>17</td><td>16</td><td></td><td>14</td><td>12</td><td>10</td><td>9</td><td>8</td><td></td><td>6</td><td>5</td><td></td><td>3</td><td>2</td><td>1</td></tr> </table>				78						72	71	70	69	68		66	65	64	63	61				58	57	56			53	52	51	50						44	43	41				40		37	35	34		32	30	29		27	26					22	21				20	19	18	17	16		14	12	10	9	8		6	5		3	2	1
			78						72	71	70	69	68		66	65	64	63	61																																																																						
			58	57	56			53	52	51	50						44	43	41																																																																						
			40		37	35	34		32	30	29		27	26					22	21																																																																					
			20	19	18	17	16		14	12	10	9	8		6	5		3	2	1																																																																					
AVAILABLE	NOT APPLICABLE	34566-2073	G	0	H	ST GRAY	<table border="1"> <tr><td></td><td></td><td></td><td>78</td><td></td><td></td><td></td><td></td><td></td><td>72</td><td>71</td><td>70</td><td>69</td><td>68</td><td></td><td>66</td><td>65</td><td>64</td><td>63</td><td>61</td></tr> <tr><td></td><td></td><td></td><td>58</td><td>57</td><td>56</td><td></td><td></td><td>53</td><td>52</td><td>51</td><td>50</td><td></td><td></td><td></td><td></td><td></td><td>44</td><td>43</td><td>41</td></tr> <tr><td></td><td></td><td></td><td>40</td><td></td><td>37</td><td>35</td><td>34</td><td></td><td>32</td><td>30</td><td>29</td><td></td><td>27</td><td>26</td><td></td><td></td><td></td><td></td><td>22</td><td>21</td></tr> <tr><td></td><td></td><td></td><td>20</td><td>19</td><td>18</td><td>17</td><td>16</td><td></td><td>12</td><td></td><td></td><td>8</td><td></td><td>6</td><td>5</td><td></td><td>3</td><td>2</td><td>1</td><td></td></tr> </table>				78						72	71	70	69	68		66	65	64	63	61				58	57	56			53	52	51	50						44	43	41				40		37	35	34		32	30	29		27	26					22	21				20	19	18	17	16		12			8		6	5		3	2	1	
			78						72	71	70	69	68		66	65	64	63	61																																																																						
			58	57	56			53	52	51	50						44	43	41																																																																						
			40		37	35	34		32	30	29		27	26					22	21																																																																					
			20	19	18	17	16		12			8		6	5		3	2	1																																																																						
AVAILABLE	NOT APPLICABLE	34566-2083	G	0	H	ST GRAY	<table border="1"> <tr><td></td><td></td><td></td><td>78</td><td></td><td></td><td></td><td></td><td></td><td>72</td><td>71</td><td>70</td><td>69</td><td>68</td><td>67</td><td>66</td><td>65</td><td>64</td><td>63</td><td>61</td></tr> <tr><td></td><td></td><td></td><td>58</td><td>57</td><td>56</td><td></td><td></td><td>53</td><td>52</td><td>51</td><td>50</td><td></td><td></td><td></td><td></td><td></td><td>44</td><td>43</td><td>41</td></tr> <tr><td></td><td></td><td></td><td>40</td><td></td><td>37</td><td>35</td><td>34</td><td></td><td>32</td><td>30</td><td>29</td><td></td><td>27</td><td>26</td><td></td><td></td><td></td><td></td><td>22</td><td>21</td></tr> <tr><td></td><td></td><td></td><td>20</td><td>19</td><td>18</td><td>17</td><td>16</td><td></td><td>12</td><td></td><td></td><td>8</td><td>7</td><td>6</td><td>5</td><td></td><td>3</td><td>2</td><td>1</td><td></td></tr> </table>				78						72	71	70	69	68	67	66	65	64	63	61				58	57	56			53	52	51	50						44	43	41				40		37	35	34		32	30	29		27	26					22	21				20	19	18	17	16		12			8	7	6	5		3	2	1	
			78						72	71	70	69	68	67	66	65	64	63	61																																																																						
			58	57	56			53	52	51	50						44	43	41																																																																						
			40		37	35	34		32	30	29		27	26					22	21																																																																					
			20	19	18	17	16		12			8	7	6	5		3	2	1																																																																						

ENTER DESCRIPTION IEC NO: UAU2014-0574 DRAWN BY: SKRAJENDRANA CHECKED BY: MVANSLAMBROU APPR: IKOSHY 2013/10/09 REV: GO	QUALITY SYMBOLS ∇=0 ∇=0 ∇=0	GENERAL TOLERANCES (UNLESS SPECIFIED) <table border="1"> <tr><th></th><th>mm</th><th>INCH</th></tr> <tr><td>4 PLACES</td><td>±---</td><td>±---</td></tr> <tr><td>3 PLACES</td><td>±---</td><td>±---</td></tr> <tr><td>2 PLACES</td><td>±---</td><td>±---</td></tr> <tr><td>1 PLACE</td><td>±---</td><td>±---</td></tr> <tr><td>0 PLACE</td><td>±---</td><td>±---</td></tr> </table>		mm	INCH	4 PLACES	±---	±---	3 PLACES	±---	±---	2 PLACES	±---	±---	1 PLACE	±---	±---	0 PLACE	±---	±---	DIMENSION STYLE MM ONLY	SCALE METRIC	DESIGN UNITS METRIC	THIRD ANGLE PROJECTION
		mm	INCH																					
	4 PLACES	±---	±---																					
	3 PLACES	±---	±---																					
2 PLACES	±---	±---																						
1 PLACE	±---	±---																						
0 PLACE	±---	±---																						
DRAWN BY: SKRAJENDRANA DATE: 2011/02/14 CHECKED BY: MVANSLAMBROU DATE: 2011/02/14 APPROVED BY:	TITLE MX123 66/73/80CKT HRNS CONN ASSY	MATERIAL NO. SEE BOM TABLE	DOCUMENT NO. SD-34566-001	SHEET NO. 25 OF 68																				
DRAFT WHERE APPLICABLE MUST REMAIN WITHIN DIMENSIONS																								
THIS DRAWING CONTAINS INFORMATION THAT IS PROPRIETARY TO MOLEX INCORPORATED AND SHOULD NOT BE USED WITHOUT WRITTEN PERMISSION																								

STATUS	GM PART #	MATERIAL #	PART/MATERIAL REVISION	WIRE DRESS OPTION	KEY OPTION	COLOR (TPA)	NUMBERS INDICATE CAVITIES OPEN FOR CIRCUITS																																																																
AVAILABLE	NOT APPLICABLE	34566-2293	G	0	C	BLUE	<table border="1"> <tr><td>72</td><td>70</td><td>68</td><td>66</td><td>63</td><td>59</td><td>57</td><td>53</td></tr> <tr><td>52</td><td>51</td><td>48</td><td>47</td><td>46</td><td>44</td><td>42</td><td>40</td><td>39</td><td>34</td><td>33</td></tr> <tr><td colspan="2">73</td><td>30</td><td>26</td><td>25</td><td>22</td><td>21</td><td></td><td></td><td></td><td></td></tr> <tr><td colspan="2"></td><td>15</td><td>14</td><td>10</td><td>9</td><td>6</td><td></td><td></td><td></td><td></td></tr> </table>	72	70	68	66	63	59	57	53	52	51	48	47	46	44	42	40	39	34	33	73		30	26	25	22	21							15	14	10	9	6																											
72	70	68	66	63	59	57	53																																																																
52	51	48	47	46	44	42	40	39	34	33																																																													
73		30	26	25	22	21																																																																	
		15	14	10	9	6																																																																	
AVAILABLE	NOT APPLICABLE	34566-2313	G	0	C	BLUE	<table border="1"> <tr><td>72</td><td>70</td><td>66</td><td>63</td><td>59</td><td>57</td><td>53</td></tr> <tr><td>52</td><td>51</td><td>46</td><td>44</td><td>42</td><td>40</td><td>39</td><td>34</td><td>33</td></tr> <tr><td colspan="2">73</td><td>30</td><td>26</td><td>25</td><td>22</td><td>21</td><td></td><td></td><td></td></tr> <tr><td colspan="2"></td><td>15</td><td>14</td><td>10</td><td>9</td><td>6</td><td></td><td></td><td></td></tr> </table>	72	70	66	63	59	57	53	52	51	46	44	42	40	39	34	33	73		30	26	25	22	21						15	14	10	9	6																															
72	70	66	63	59	57	53																																																																	
52	51	46	44	42	40	39	34	33																																																															
73		30	26	25	22	21																																																																	
		15	14	10	9	6																																																																	
AVAILABLE	NOT APPLICABLE	34566-2323	G	0	C	BLUE	<table border="1"> <tr><td>72</td><td>70</td><td>68</td><td>66</td><td>63</td><td>59</td><td>57</td><td>53</td></tr> <tr><td>52</td><td>51</td><td>48</td><td>47</td><td>46</td><td>44</td><td>42</td><td>40</td><td>39</td><td>34</td><td>33</td></tr> <tr><td colspan="2">73</td><td>30</td><td>26</td><td>25</td><td>22</td><td>21</td><td>20</td><td></td><td></td><td></td></tr> <tr><td colspan="2"></td><td>15</td><td>14</td><td>10</td><td>9</td><td>6</td><td>5</td><td>4</td><td></td><td></td></tr> </table>	72	70	68	66	63	59	57	53	52	51	48	47	46	44	42	40	39	34	33	73		30	26	25	22	21	20						15	14	10	9	6	5	4																									
72	70	68	66	63	59	57	53																																																																
52	51	48	47	46	44	42	40	39	34	33																																																													
73		30	26	25	22	21	20																																																																
		15	14	10	9	6	5	4																																																															
AVAILABLE	NOT APPLICABLE	34566-2333	G	0	A	BLACK	<table border="1"> <tr><td>71</td><td>69</td><td>68</td><td>65</td><td>64</td><td>63</td><td>61</td><td>59</td><td>57</td><td>56</td><td>34</td><td>33</td></tr> <tr><td>52</td><td>50</td><td>49</td><td>47</td><td>30</td><td>29</td><td>28</td><td>27</td><td>24</td><td>23</td><td>22</td><td>20</td><td>19</td><td>18</td></tr> <tr><td colspan="2">73</td><td>32</td><td>31</td><td>30</td><td>29</td><td>28</td><td>27</td><td>24</td><td>23</td><td>22</td><td>20</td><td>19</td><td>18</td></tr> <tr><td colspan="2"></td><td>16</td><td>13</td><td>12</td><td>11</td><td>10</td><td>9</td><td></td><td></td><td></td><td></td><td></td><td>1</td></tr> </table>	71	69	68	65	64	63	61	59	57	56	34	33	52	50	49	47	30	29	28	27	24	23	22	20	19	18	73		32	31	30	29	28	27	24	23	22	20	19	18			16	13	12	11	10	9						1										
71	69	68	65	64	63	61	59	57	56	34	33																																																												
52	50	49	47	30	29	28	27	24	23	22	20	19	18																																																										
73		32	31	30	29	28	27	24	23	22	20	19	18																																																										
		16	13	12	11	10	9						1																																																										
AVAILABLE	NOT APPLICABLE	34566-2343	G	0	A	BLACK	<table border="1"> <tr><td>72</td><td>70</td><td>68</td><td>67</td><td>66</td><td>65</td><td>58</td><td>57</td><td>55</td><td></td><td></td><td></td></tr> <tr><td></td><td>49</td><td>47</td><td>44</td><td>43</td><td>42</td><td>41</td><td>39</td><td>37</td><td>35</td><td></td><td></td></tr> <tr><td colspan="2">73</td><td>32</td><td>30</td><td>27</td><td>25</td><td>24</td><td>21</td><td>20</td><td>19</td><td>18</td><td>17</td></tr> <tr><td colspan="2"></td><td>15</td><td>14</td><td>13</td><td>9</td><td>8</td><td>6</td><td>5</td><td>3</td><td>1</td><td></td></tr> </table>	72	70	68	67	66	65	58	57	55					49	47	44	43	42	41	39	37	35			73		32	30	27	25	24	21	20	19	18	17			15	14	13	9	8	6	5	3	1																	
72	70	68	67	66	65	58	57	55																																																															
	49	47	44	43	42	41	39	37	35																																																														
73		32	30	27	25	24	21	20	19	18	17																																																												
		15	14	13	9	8	6	5	3	1																																																													
AVAILABLE	NOT APPLICABLE	34566-2353	G	0	A	BLACK	<table border="1"> <tr><td>72</td><td>70</td><td>67</td><td>66</td><td>65</td><td>58</td><td>57</td><td>55</td><td></td><td></td><td></td><td></td></tr> <tr><td></td><td>49</td><td>47</td><td>44</td><td>43</td><td>42</td><td>41</td><td>39</td><td>37</td><td>35</td><td></td><td></td></tr> <tr><td colspan="2">73</td><td>32</td><td>30</td><td>27</td><td>25</td><td>24</td><td>21</td><td>20</td><td>19</td><td>18</td><td>17</td></tr> <tr><td colspan="2"></td><td>15</td><td>14</td><td>13</td><td>9</td><td>8</td><td>6</td><td>5</td><td>3</td><td>1</td><td></td></tr> </table>	72	70	67	66	65	58	57	55						49	47	44	43	42	41	39	37	35			73		32	30	27	25	24	21	20	19	18	17			15	14	13	9	8	6	5	3	1																	
72	70	67	66	65	58	57	55																																																																
	49	47	44	43	42	41	39	37	35																																																														
73		32	30	27	25	24	21	20	19	18	17																																																												
		15	14	13	9	8	6	5	3	1																																																													
AVAILABLE	NOT APPLICABLE	34566-2363	G	0	C	BLUE	<table border="1"> <tr><td>72</td><td>70</td><td>67</td><td>66</td><td>63</td><td>62</td><td>59</td><td>57</td><td>53</td></tr> <tr><td>52</td><td>51</td><td>46</td><td>44</td><td>42</td><td>40</td><td>39</td><td>38</td><td>34</td><td>33</td></tr> <tr><td colspan="2">73</td><td>32</td><td>30</td><td>27</td><td>26</td><td>25</td><td>22</td><td>21</td><td>20</td><td></td></tr> <tr><td colspan="2"></td><td>15</td><td>14</td><td>10</td><td>9</td><td>6</td><td>5</td><td>4</td><td></td><td></td></tr> </table>	72	70	67	66	63	62	59	57	53	52	51	46	44	42	40	39	38	34	33	73		32	30	27	26	25	22	21	20				15	14	10	9	6	5	4																									
72	70	67	66	63	62	59	57	53																																																															
52	51	46	44	42	40	39	38	34	33																																																														
73		32	30	27	26	25	22	21	20																																																														
		15	14	10	9	6	5	4																																																															
AVAILABLE	NOT APPLICABLE	34566-2373	G	0	B	ST GRAY	<table border="1"> <tr><td>68</td><td>67</td><td>66</td><td>65</td><td>64</td><td>61</td><td>60</td><td>59</td><td>58</td><td>57</td><td>55</td><td>54</td><td>53</td></tr> <tr><td>51</td><td>50</td><td>49</td><td>48</td><td>47</td><td>46</td><td>45</td><td>43</td><td>42</td><td>41</td><td>40</td><td>39</td><td>38</td><td>37</td><td>35</td><td>34</td><td>33</td></tr> <tr><td colspan="2">73</td><td>32</td><td>31</td><td>30</td><td>26</td><td>24</td><td>23</td><td>22</td><td>21</td><td>20</td><td></td><td></td><td></td><td></td><td></td><td></td></tr> <tr><td colspan="2"></td><td>16</td><td>15</td><td>14</td><td>13</td><td>10</td><td>9</td><td>8</td><td>7</td><td>6</td><td>5</td><td>4</td><td>3</td><td>2</td><td></td><td></td></tr> </table>	68	67	66	65	64	61	60	59	58	57	55	54	53	51	50	49	48	47	46	45	43	42	41	40	39	38	37	35	34	33	73		32	31	30	26	24	23	22	21	20									16	15	14	13	10	9	8	7	6	5	4	3	2		
68	67	66	65	64	61	60	59	58	57	55	54	53																																																											
51	50	49	48	47	46	45	43	42	41	40	39	38	37	35	34	33																																																							
73		32	31	30	26	24	23	22	21	20																																																													
		16	15	14	13	10	9	8	7	6	5	4	3	2																																																									
AVAILABLE	NOT APPLICABLE	34566-2383	G	0	B	ST GRAY	<table border="1"> <tr><td>65</td><td>59</td><td>57</td><td>55</td><td>53</td></tr> <tr><td>50</td><td>49</td><td>48</td><td>46</td><td>39</td><td>37</td><td>35</td><td>33</td></tr> <tr><td colspan="2">73</td><td>29</td><td>24</td><td>23</td><td>21</td><td></td><td></td><td></td><td></td><td></td><td></td><td></td></tr> <tr><td colspan="2"></td><td>15</td><td>7</td><td>6</td><td>5</td><td>4</td><td>3</td><td></td><td></td><td></td><td></td><td></td></tr> </table>	65	59	57	55	53	50	49	48	46	39	37	35	33	73		29	24	23	21										15	7	6	5	4	3																														
65	59	57	55	53																																																																			
50	49	48	46	39	37	35	33																																																																
73		29	24	23	21																																																																		
		15	7	6	5	4	3																																																																

ENTER DESCRIPTION IEC NO: UAU2014-0574 DRAWN BY: SKRAJENDRANA 2013/10/08 CHKD: SKRAJENDRANA 2013/10/08 APPR: VIOSHY 2013/10/09 REV: GO	QUALITY SYMBOLS	GENERAL TOLERANCES (UNLESS SPECIFIED)	DIMENSION STYLE	SCALE	DESIGN UNITS	THIRD ANGLE PROJECTION	
	$\nabla=0$ $\nabla=0$ $\nabla=0$	4 PLACES ±---+---+---+--- 3 PLACES ±---+---+---+--- 2 PLACES ±---+---+---+--- 1 PLACE ±---+---+---+--- 0 PLACE ±---+---+---+---	mm INCH ±---+---+---+--- ±---+---+---+--- ±---+---+---+--- ±---+---+---+--- ±---+---+---+---	MM ONLY		METRIC	<input checked="" type="checkbox"/> THIRD ANGLE <input type="checkbox"/> PROJECTION
		ANGULAR ±---+---+---+--- DRAFT WHERE APPLICABLE MUST REMAIN WITHIN DIMENSIONS	DRAWN BY: SKRAJENDRANA 2011/02/14 CHECKED BY: MYANSLAMBROU 2011/02/14 APPROVED BY:	DATE	DATE	DATE	TITLE
		SEE BOM TABLE	MATERIAL NO.	DOCUMENT NO.	MX123 66/73/80CKT HRNS CONN ASSY molex SD-34566-001		

STATUS	GM PART #	MATERIAL #	PART/MATERIAL REVISION	WIRE DRESS OPTION	KEY OPTION	COLOR (TPA)	NUMBERS INDICATE CAVITIES OPEN FOR CIRCUITS																																																																																																											
AVAILABLE	NOT APPLICABLE	34566-2483	G	0	A	BLACK	<table border="1"> <tr><td></td><td></td><td></td><td>69</td><td></td><td></td><td></td><td></td><td></td><td></td><td>63</td><td>62</td><td>61</td><td></td><td></td><td>58</td><td>57</td><td>56</td><td>55</td><td>54</td><td>53</td></tr> <tr><td>52</td><td>51</td><td>49</td><td></td><td></td><td></td><td></td><td></td><td></td><td>44</td><td>43</td><td>42</td><td>41</td><td></td><td></td><td></td><td>37</td><td>36</td><td>35</td><td>34</td><td>33</td></tr> <tr><td colspan="20">73</td></tr> <tr><td></td><td></td><td></td><td>32</td><td></td><td></td><td></td><td></td><td></td><td>29</td><td>28</td><td>27</td><td>26</td><td></td><td></td><td>23</td><td></td><td></td><td></td><td>19</td><td>18</td></tr> <tr><td></td><td></td><td></td><td>16</td><td></td><td></td><td></td><td></td><td></td><td>13</td><td>12</td><td>11</td><td>10</td><td></td><td></td><td>8</td><td></td><td></td><td></td><td>3</td><td></td></tr> </table>				69							63	62	61			58	57	56	55	54	53	52	51	49							44	43	42	41				37	36	35	34	33	73																							32						29	28	27	26			23				19	18				16						13	12	11	10			8				3				
			69							63	62	61			58	57	56	55	54	53																																																																																														
52	51	49							44	43	42	41				37	36	35	34	33																																																																																														
73																																																																																																																		
			32						29	28	27	26			23				19	18																																																																																														
			16						13	12	11	10			8				3																																																																																															
AVAILABLE	NOT APPLICABLE	34566-2493	G	0	B	ST GRY	<table border="1"> <tr><td>72</td><td>71</td><td>70</td><td></td><td>68</td><td>67</td><td>66</td><td></td><td></td><td></td><td>62</td><td>61</td><td>60</td><td>59</td><td>58</td><td>57</td><td>56</td><td>55</td><td>54</td><td>53</td></tr> <tr><td>52</td><td>51</td><td>50</td><td></td><td>48</td><td>47</td><td>46</td><td></td><td></td><td></td><td>42</td><td>41</td><td>40</td><td>39</td><td>38</td><td>37</td><td>36</td><td>35</td><td>34</td><td>33</td></tr> <tr><td colspan="20">73</td></tr> <tr><td></td><td></td><td></td><td>32</td><td>31</td><td>30</td><td>29</td><td>28</td><td>27</td><td>26</td><td>25</td><td>24</td><td></td><td></td><td></td><td></td><td></td><td></td><td></td><td>17</td></tr> <tr><td></td><td></td><td></td><td>16</td><td>15</td><td>14</td><td>13</td><td></td><td></td><td></td><td>10</td><td>8</td><td></td><td></td><td></td><td></td><td></td><td></td><td></td><td>2</td><td>1</td></tr> </table>	72	71	70		68	67	66				62	61	60	59	58	57	56	55	54	53	52	51	50		48	47	46				42	41	40	39	38	37	36	35	34	33	73																							32	31	30	29	28	27	26	25	24								17				16	15	14	13				10	8								2	1						
72	71	70		68	67	66				62	61	60	59	58	57	56	55	54	53																																																																																															
52	51	50		48	47	46				42	41	40	39	38	37	36	35	34	33																																																																																															
73																																																																																																																		
			32	31	30	29	28	27	26	25	24								17																																																																																															
			16	15	14	13				10	8								2	1																																																																																														
AVAILABLE	NOT APPLICABLE	34566-2513	G	0	C	BLUE	<table border="1"> <tr><td>72</td><td>71</td><td>70</td><td></td><td>68</td><td>67</td><td>66</td><td></td><td></td><td></td><td>63</td><td>62</td><td></td><td></td><td>59</td><td></td><td>57</td><td></td><td></td><td>53</td></tr> <tr><td>52</td><td>51</td><td></td><td></td><td>48</td><td>47</td><td>46</td><td></td><td></td><td></td><td>44</td><td>42</td><td>40</td><td>39</td><td></td><td></td><td></td><td></td><td></td><td>34</td><td>33</td></tr> <tr><td colspan="20">73</td></tr> <tr><td></td><td></td><td></td><td>32</td><td></td><td>30</td><td></td><td></td><td></td><td>27</td><td>26</td><td>25</td><td></td><td></td><td></td><td>22</td><td>21</td><td>20</td><td></td><td></td></tr> <tr><td></td><td></td><td></td><td></td><td>15</td><td>14</td><td></td><td></td><td></td><td></td><td>10</td><td>9</td><td></td><td></td><td></td><td>6</td><td>5</td><td>4</td><td></td><td></td></tr> </table>	72	71	70		68	67	66				63	62			59		57			53	52	51			48	47	46				44	42	40	39						34	33	73																							32		30				27	26	25				22	21	20							15	14					10	9				6	5	4								
72	71	70		68	67	66				63	62			59		57			53																																																																																															
52	51			48	47	46				44	42	40	39						34	33																																																																																														
73																																																																																																																		
			32		30				27	26	25				22	21	20																																																																																																	
				15	14					10	9				6	5	4																																																																																																	
AVAILABLE	NOT APPLICABLE	34566-2523	G	0	A	BLACK	<table border="1"> <tr><td>72</td><td>71</td><td>70</td><td>69</td><td>68</td><td>67</td><td>66</td><td></td><td>65</td><td>64</td><td>63</td><td>62</td><td></td><td>60</td><td>59</td><td></td><td></td><td></td><td>55</td><td>54</td><td>53</td></tr> <tr><td>52</td><td></td><td></td><td>49</td><td>48</td><td></td><td></td><td></td><td>45</td><td>44</td><td>43</td><td>42</td><td></td><td>41</td><td>40</td><td>39</td><td></td><td></td><td></td><td>35</td><td>34</td><td>33</td></tr> <tr><td colspan="20">73</td></tr> <tr><td></td><td></td><td></td><td>32</td><td></td><td></td><td></td><td></td><td>29</td><td>28</td><td>27</td><td>26</td><td>25</td><td>24</td><td>23</td><td></td><td></td><td></td><td></td><td>19</td><td>18</td><td>17</td></tr> <tr><td></td><td></td><td></td><td>16</td><td></td><td></td><td></td><td></td><td>13</td><td>12</td><td>11</td><td></td><td></td><td>9</td><td>8</td><td>7</td><td>6</td><td>5</td><td>4</td><td>3</td><td>2</td><td>1</td></tr> </table>	72	71	70	69	68	67	66		65	64	63	62		60	59				55	54	53	52			49	48				45	44	43	42		41	40	39				35	34	33	73																							32					29	28	27	26	25	24	23					19	18	17				16					13	12	11			9	8	7	6	5	4	3	2	1
72	71	70	69	68	67	66		65	64	63	62		60	59				55	54	53																																																																																														
52			49	48				45	44	43	42		41	40	39				35	34	33																																																																																													
73																																																																																																																		
			32					29	28	27	26	25	24	23					19	18	17																																																																																													
			16					13	12	11			9	8	7	6	5	4	3	2	1																																																																																													
AVAILABLE	NOT APPLICABLE	34566-2533	G	0	B	ST GRY	<table border="1"> <tr><td></td><td></td><td></td><td></td><td>67</td><td>66</td><td>65</td><td></td><td></td><td></td><td>63</td><td></td><td></td><td></td><td>59</td><td>58</td><td>57</td><td>56</td><td>55</td><td></td><td>53</td></tr> <tr><td></td><td></td><td>50</td><td>49</td><td>48</td><td></td><td>46</td><td>45</td><td>43</td><td></td><td></td><td></td><td></td><td></td><td>39</td><td>38</td><td>37</td><td>36</td><td>35</td><td>34</td><td>33</td></tr> <tr><td colspan="20">73</td></tr> <tr><td></td><td></td><td></td><td></td><td></td><td></td><td></td><td>29</td><td>27</td><td></td><td></td><td></td><td></td><td></td><td>23</td><td>22</td><td>21</td><td></td><td></td><td>18</td><td></td></tr> <tr><td></td><td></td><td></td><td></td><td></td><td></td><td></td><td>16</td><td>15</td><td>14</td><td>13</td><td></td><td></td><td></td><td>8</td><td>7</td><td>6</td><td>5</td><td>4</td><td>3</td><td></td></tr> </table>					67	66	65				63				59	58	57	56	55		53			50	49	48		46	45	43						39	38	37	36	35	34	33	73																											29	27						23	22	21			18									16	15	14	13				8	7	6	5	4	3				
				67	66	65				63				59	58	57	56	55		53																																																																																														
		50	49	48		46	45	43						39	38	37	36	35	34	33																																																																																														
73																																																																																																																		
							29	27						23	22	21			18																																																																																															
							16	15	14	13				8	7	6	5	4	3																																																																																															
AVAILABLE	NOT APPLICABLE	34566-2543	G	0	C	BLUE	<table border="1"> <tr><td>72</td><td>71</td><td>70</td><td></td><td></td><td></td><td>66</td><td></td><td></td><td></td><td>63</td><td></td><td></td><td></td><td>59</td><td></td><td>57</td><td></td><td></td><td></td><td>53</td></tr> <tr><td>52</td><td>51</td><td></td><td></td><td></td><td></td><td>46</td><td></td><td></td><td></td><td>44</td><td>42</td><td>40</td><td>39</td><td></td><td></td><td></td><td></td><td></td><td></td><td>34</td><td>33</td></tr> <tr><td colspan="20">73</td></tr> <tr><td></td><td></td><td></td><td></td><td></td><td></td><td>32</td><td></td><td></td><td></td><td>27</td><td>26</td><td>25</td><td></td><td></td><td></td><td>22</td><td>21</td><td></td><td></td><td></td></tr> <tr><td></td><td></td><td></td><td></td><td></td><td></td><td></td><td>15</td><td>14</td><td></td><td></td><td></td><td>10</td><td>9</td><td></td><td></td><td>6</td><td></td><td></td><td></td><td></td></tr> </table>	72	71	70				66				63				59		57				53	52	51					46				44	42	40	39							34	33	73																										32				27	26	25				22	21											15	14				10	9			6						
72	71	70				66				63				59		57				53																																																																																														
52	51					46				44	42	40	39							34	33																																																																																													
73																																																																																																																		
						32				27	26	25				22	21																																																																																																	
							15	14				10	9			6																																																																																																		
AVAILABLE	NOT APPLICABLE	34566-2553	G	9	B	ST GRY	<table border="1"> <tr><td>72</td><td>71</td><td>70</td><td></td><td>68</td><td>67</td><td>66</td><td></td><td></td><td></td><td>62</td><td>61</td><td>60</td><td>59</td><td>58</td><td>57</td><td>56</td><td>55</td><td>54</td><td>53</td></tr> <tr><td>52</td><td>51</td><td>50</td><td></td><td>48</td><td>47</td><td>46</td><td></td><td></td><td></td><td>42</td><td>41</td><td>40</td><td>39</td><td>38</td><td>37</td><td>36</td><td>35</td><td>34</td><td>33</td></tr> <tr><td colspan="20">73</td></tr> <tr><td></td><td></td><td></td><td></td><td>32</td><td>31</td><td>30</td><td>29</td><td>28</td><td>27</td><td>26</td><td>25</td><td>24</td><td>23</td><td></td><td></td><td></td><td></td><td></td><td></td><td></td></tr> <tr><td></td><td></td><td></td><td></td><td>16</td><td>15</td><td>14</td><td>13</td><td></td><td></td><td>10</td><td>9</td><td>8</td><td></td><td></td><td></td><td></td><td></td><td></td><td></td><td></td></tr> </table>	72	71	70		68	67	66				62	61	60	59	58	57	56	55	54	53	52	51	50		48	47	46				42	41	40	39	38	37	36	35	34	33	73																								32	31	30	29	28	27	26	25	24	23												16	15	14	13			10	9	8													
72	71	70		68	67	66				62	61	60	59	58	57	56	55	54	53																																																																																															
52	51	50		48	47	46				42	41	40	39	38	37	36	35	34	33																																																																																															
73																																																																																																																		
				32	31	30	29	28	27	26	25	24	23																																																																																																					
				16	15	14	13			10	9	8																																																																																																						
AVAILABLE	NOT APPLICABLE	34566-2563	G	9	A	BLACK	<table border="1"> <tr><td></td><td></td><td></td><td>69</td><td></td><td></td><td></td><td></td><td></td><td></td><td>63</td><td>62</td><td>61</td><td></td><td></td><td>58</td><td>57</td><td>56</td><td>55</td><td>54</td><td>53</td></tr> <tr><td>52</td><td>51</td><td>50</td><td>49</td><td></td><td></td><td></td><td></td><td></td><td></td><td>44</td><td>43</td><td>42</td><td>41</td><td></td><td></td><td>37</td><td>36</td><td>35</td><td>34</td><td>33</td></tr> <tr><td colspan="20">73</td></tr> <tr><td></td><td></td><td></td><td></td><td>32</td><td></td><td></td><td></td><td></td><td></td><td>29</td><td>28</td><td>27</td><td>26</td><td></td><td></td><td></td><td></td><td></td><td>19</td><td>18</td></tr> <tr><td></td><td></td><td></td><td></td><td>16</td><td></td><td>14</td><td>13</td><td>12</td><td>11</td><td>10</td><td></td><td></td><td></td><td></td><td></td><td></td><td></td><td></td><td>3</td><td></td></tr> </table>				69							63	62	61			58	57	56	55	54	53	52	51	50	49							44	43	42	41			37	36	35	34	33	73																								32						29	28	27	26						19	18					16		14	13	12	11	10									3				
			69							63	62	61			58	57	56	55	54	53																																																																																														
52	51	50	49							44	43	42	41			37	36	35	34	33																																																																																														
73																																																																																																																		
				32						29	28	27	26						19	18																																																																																														
				16		14	13	12	11	10									3																																																																																															
AVAILABLE	NOT APPLICABLE	34566-2573	G	9	C	BLUE	<table border="1"> <tr><td>72</td><td>71</td><td>70</td><td></td><td>67</td><td>66</td><td></td><td></td><td></td><td></td><td>63</td><td>62</td><td></td><td></td><td>59</td><td></td><td>57</td><td></td><td></td><td></td><td>53</td></tr> <tr><td>52</td><td>51</td><td></td><td></td><td>46</td><td></td><td>44</td><td></td><td></td><td></td><td>42</td><td>40</td><td>39</td><td></td><td></td><td></td><td></td><td></td><td></td><td></td><td>34</td><td>33</td></tr> <tr><td colspan="20">73</td></tr> <tr><td></td><td></td><td></td><td></td><td></td><td>30</td><td></td><td></td><td></td><td></td><td>26</td><td>25</td><td></td><td></td><td></td><td>22</td><td>21</td><td>20</td><td></td><td></td><td></td></tr> <tr><td></td><td></td><td></td><td></td><td></td><td>15</td><td>14</td><td></td><td></td><td></td><td></td><td>10</td><td>9</td><td></td><td></td><td>6</td><td>5</td><td>4</td><td></td><td></td><td></td></tr> </table>	72	71	70		67	66					63	62			59		57				53	52	51			46		44				42	40	39								34	33	73																									30					26	25				22	21	20									15	14					10	9			6	5	4					
72	71	70		67	66					63	62			59		57				53																																																																																														
52	51			46		44				42	40	39								34	33																																																																																													
73																																																																																																																		
					30					26	25				22	21	20																																																																																																	
					15	14					10	9			6	5	4																																																																																																	

ENTER DESCRIPTION IEC NO: UAU2014-0574 DRAWNSKRAJENDRANA 2013/10/08 CHKD: APPR:IKOSHY 2013/10/09 REV: GO	QUALITY SYMBOLS	GENERAL TOLERANCES (UNLESS SPECIFIED)	DIMENSION STYLE	SCALE	DESIGN UNITS	THIRD ANGLE PROJECTION
	▽=0	4 PLACES ±--- INCH	MM ONLY		METRIC	
	▽=0	3 PLACES ±--- INCH	DRAWN BY	DATE	TITLE	
	▽=0	2 PLACES ±--- INCH	SKRAJENDRANA 2011/02/14	2011/02/14	66/73/80CKT HRNS CONN ASSY	
	1 PLACE ±--- INCH	CHECKED BY	DATE			
	0 PLACE ±--- INCH	MYANSLAMBROU 2011/02/14	2011/02/14			
	ANGULAR ±---°	APPROVED BY	DATE			
	DRAFT WHERE APPLICABLE MUST REMAIN WITHIN DIMENSIONS					
		MATERIAL NO.	DOCUMENT NO.			
		SEE BOM TABLE	SD-34566-001			
		THIS DRAWING CONTAINS INFORMATION THAT IS PROPRIETARY TO MOLEX INCORPORATED AND SHOULD NOT BE USED WITHOUT WRITTEN PERMISSION				
		SIZE				

STATUS	GM PART #	MATERIAL #	PART/MATERIAL REVISION	WIRE DRESS OPTION	KEY OPTION	COLOR (TPA)	NUMBERS INDICATE CAVITIES OPEN FOR CIRCUITS																																																																										
AVAILABLE	NOT APPLICABLE	34566-2583	G	0	A	BLACK	<table border="1"> <tr><td></td><td></td><td>69</td><td></td><td></td><td></td><td>63</td><td></td><td></td><td>58</td><td>56</td><td>55</td><td>54</td><td>53</td></tr> <tr><td>52</td><td>51</td><td>50</td><td>49</td><td></td><td></td><td>44</td><td>43</td><td>42</td><td>41</td><td>39</td><td></td><td>36</td><td>35</td><td>34</td><td>33</td></tr> <tr><td></td><td></td><td>73</td><td></td><td>32</td><td></td><td>28</td><td>26</td><td></td><td></td><td></td><td></td><td>19</td><td>18</td><td></td><td></td></tr> <tr><td></td><td></td><td></td><td></td><td>16</td><td></td><td>14</td><td>12</td><td>10</td><td></td><td></td><td></td><td>3</td><td></td><td></td><td></td></tr> </table>			69				63			58	56	55	54	53	52	51	50	49			44	43	42	41	39		36	35	34	33			73		32		28	26					19	18							16		14	12	10				3															
		69				63			58	56	55	54	53																																																																				
52	51	50	49			44	43	42	41	39		36	35	34	33																																																																		
		73		32		28	26					19	18																																																																				
				16		14	12	10				3																																																																					
AVAILABLE	NOT APPLICABLE	34566-2593	G	0	C	BLUE	<table border="1"> <tr><td>72</td><td>70</td><td></td><td></td><td>66</td><td></td><td>63</td><td>62</td><td></td><td>59</td><td>57</td><td></td><td></td><td></td><td>53</td><td></td></tr> <tr><td>52</td><td>51</td><td></td><td></td><td>46</td><td>44</td><td>42</td><td>40</td><td>39</td><td></td><td></td><td></td><td></td><td></td><td>34</td><td>33</td></tr> <tr><td></td><td></td><td>73</td><td></td><td>32</td><td>30</td><td></td><td>27</td><td>26</td><td>25</td><td></td><td>22</td><td>21</td><td></td><td></td><td></td></tr> <tr><td></td><td></td><td></td><td></td><td>15</td><td>14</td><td></td><td></td><td>10</td><td>9</td><td></td><td>6</td><td></td><td></td><td></td><td></td></tr> </table>	72	70			66		63	62		59	57				53		52	51			46	44	42	40	39						34	33			73		32	30		27	26	25		22	21								15	14			10	9		6														
72	70			66		63	62		59	57				53																																																																			
52	51			46	44	42	40	39						34	33																																																																		
		73		32	30		27	26	25		22	21																																																																					
				15	14			10	9		6																																																																						
AVAILABLE	NOT APPLICABLE	34566-2613	G	9	C	BLUE	<table border="1"> <tr><td>72</td><td>70</td><td></td><td>67</td><td>66</td><td></td><td>63</td><td>62</td><td></td><td>59</td><td>57</td><td></td><td></td><td></td><td>53</td><td></td></tr> <tr><td>52</td><td>51</td><td></td><td></td><td>46</td><td>44</td><td>42</td><td>40</td><td>39</td><td></td><td></td><td></td><td></td><td></td><td>34</td><td>33</td></tr> <tr><td></td><td></td><td>73</td><td></td><td></td><td>30</td><td></td><td>27</td><td>26</td><td>25</td><td></td><td>22</td><td>21</td><td>20</td><td></td><td></td></tr> <tr><td></td><td></td><td></td><td></td><td>15</td><td>14</td><td></td><td></td><td>10</td><td>9</td><td></td><td>6</td><td>5</td><td>4</td><td></td><td></td></tr> </table>	72	70		67	66		63	62		59	57				53		52	51			46	44	42	40	39						34	33			73			30		27	26	25		22	21	20							15	14			10	9		6	5	4												
72	70		67	66		63	62		59	57				53																																																																			
52	51			46	44	42	40	39						34	33																																																																		
		73			30		27	26	25		22	21	20																																																																				
				15	14			10	9		6	5	4																																																																				
AVAILABLE	NOT APPLICABLE	34566-2623	G	0	A	BLACK	<table border="1"> <tr><td>71</td><td>69</td><td>68</td><td>67</td><td></td><td>65</td><td>64</td><td>63</td><td></td><td>61</td><td>59</td><td></td><td>57</td><td>56</td><td></td><td></td></tr> <tr><td></td><td>50</td><td>49</td><td></td><td>47</td><td></td><td></td><td></td><td></td><td>41</td><td></td><td></td><td>38</td><td>37</td><td>36</td><td>34</td><td>33</td></tr> <tr><td></td><td></td><td>73</td><td></td><td>32</td><td>31</td><td>30</td><td>29</td><td>28</td><td>27</td><td></td><td>24</td><td>23</td><td></td><td>20</td><td>19</td><td>18</td></tr> <tr><td></td><td></td><td></td><td></td><td>16</td><td></td><td></td><td>13</td><td>12</td><td>11</td><td>10</td><td>9</td><td>7</td><td></td><td>4</td><td></td><td></td></tr> </table>	71	69	68	67		65	64	63		61	59		57	56				50	49		47					41			38	37	36	34	33			73		32	31	30	29	28	27		24	23		20	19	18					16			13	12	11	10	9	7		4									
71	69	68	67		65	64	63		61	59		57	56																																																																				
	50	49		47					41			38	37	36	34	33																																																																	
		73		32	31	30	29	28	27		24	23		20	19	18																																																																	
				16			13	12	11	10	9	7		4																																																																			
AVAILABLE	NOT APPLICABLE	34566-2633	G	0	A	BLACK	<table border="1"> <tr><td>71</td><td>69</td><td>68</td><td>67</td><td></td><td>65</td><td>64</td><td></td><td></td><td>61</td><td>59</td><td></td><td>57</td><td>56</td><td></td><td></td></tr> <tr><td></td><td>50</td><td>49</td><td></td><td>47</td><td></td><td></td><td></td><td></td><td>41</td><td></td><td></td><td>38</td><td>37</td><td>36</td><td></td><td>33</td></tr> <tr><td></td><td></td><td>73</td><td></td><td>32</td><td>31</td><td>30</td><td>29</td><td>28</td><td>27</td><td></td><td>24</td><td>23</td><td></td><td>20</td><td>19</td><td>18</td></tr> <tr><td></td><td></td><td></td><td></td><td>16</td><td></td><td></td><td></td><td></td><td>11</td><td>10</td><td>9</td><td>7</td><td></td><td>4</td><td></td><td></td></tr> </table>	71	69	68	67		65	64			61	59		57	56				50	49		47					41			38	37	36		33			73		32	31	30	29	28	27		24	23		20	19	18					16					11	10	9	7		4									
71	69	68	67		65	64			61	59		57	56																																																																				
	50	49		47					41			38	37	36		33																																																																	
		73		32	31	30	29	28	27		24	23		20	19	18																																																																	
				16					11	10	9	7		4																																																																			
AVAILABLE	NOT APPLICABLE	34566-2643	G	0	A	BLACK	<table border="1"> <tr><td>71</td><td>69</td><td>68</td><td>67</td><td></td><td>65</td><td>64</td><td>63</td><td></td><td>61</td><td>59</td><td></td><td>57</td><td>56</td><td></td><td></td></tr> <tr><td></td><td>50</td><td>49</td><td></td><td>47</td><td></td><td></td><td></td><td></td><td>41</td><td>39</td><td>38</td><td>37</td><td>36</td><td></td><td>34</td><td>33</td></tr> <tr><td></td><td></td><td>73</td><td></td><td>32</td><td>31</td><td>30</td><td>29</td><td>28</td><td>27</td><td></td><td>24</td><td>23</td><td>22</td><td>20</td><td>19</td><td>18</td></tr> <tr><td></td><td></td><td></td><td></td><td>16</td><td></td><td></td><td></td><td></td><td>13</td><td>12</td><td>11</td><td>10</td><td>9</td><td>7</td><td></td><td>4</td></tr> </table>	71	69	68	67		65	64	63		61	59		57	56				50	49		47					41	39	38	37	36		34	33			73		32	31	30	29	28	27		24	23	22	20	19	18					16					13	12	11	10	9	7		4							
71	69	68	67		65	64	63		61	59		57	56																																																																				
	50	49		47					41	39	38	37	36		34	33																																																																	
		73		32	31	30	29	28	27		24	23	22	20	19	18																																																																	
				16					13	12	11	10	9	7		4																																																																	
AVAILABLE	NOT APPLICABLE	34566-2653	G	0	A	BLACK	<table border="1"> <tr><td>71</td><td>69</td><td>68</td><td>67</td><td></td><td>65</td><td>64</td><td></td><td></td><td>61</td><td>59</td><td></td><td>57</td><td>56</td><td></td><td></td></tr> <tr><td></td><td>50</td><td>49</td><td></td><td>47</td><td></td><td></td><td></td><td></td><td>41</td><td>39</td><td>38</td><td>37</td><td>36</td><td></td><td>34</td><td>33</td></tr> <tr><td></td><td></td><td>73</td><td></td><td>32</td><td>31</td><td>30</td><td>29</td><td>28</td><td>27</td><td></td><td>24</td><td>23</td><td>22</td><td>20</td><td>19</td><td>18</td></tr> <tr><td></td><td></td><td></td><td></td><td>16</td><td></td><td></td><td></td><td></td><td>11</td><td>10</td><td>9</td><td>7</td><td></td><td>4</td><td></td><td></td></tr> </table>	71	69	68	67		65	64			61	59		57	56				50	49		47					41	39	38	37	36		34	33			73		32	31	30	29	28	27		24	23	22	20	19	18					16					11	10	9	7		4									
71	69	68	67		65	64			61	59		57	56																																																																				
	50	49		47					41	39	38	37	36		34	33																																																																	
		73		32	31	30	29	28	27		24	23	22	20	19	18																																																																	
				16					11	10	9	7		4																																																																			
AVAILABLE	NOT APPLICABLE	34566-2663	G	0	H	ST GRAY	<table border="1"> <tr><td>79</td><td>78</td><td>77</td><td>76</td><td>75</td><td>74</td><td>73</td><td>72</td><td>71</td><td>70</td><td>69</td><td>68</td><td></td><td>66</td><td>65</td><td>64</td><td>63</td><td>61</td></tr> <tr><td>60</td><td>59</td><td>58</td><td>57</td><td>56</td><td></td><td></td><td>53</td><td>52</td><td>50</td><td></td><td></td><td></td><td></td><td></td><td>44</td><td>43</td><td>41</td></tr> <tr><td>40</td><td>39</td><td>38</td><td>37</td><td></td><td>35</td><td>34</td><td></td><td>32</td><td>30</td><td>29</td><td></td><td>27</td><td>26</td><td></td><td></td><td></td><td>22</td><td>21</td></tr> <tr><td>20</td><td>19</td><td>18</td><td>17</td><td></td><td></td><td></td><td>13</td><td>12</td><td></td><td></td><td></td><td>8</td><td>6</td><td>5</td><td></td><td>3</td><td>2</td><td></td></tr> </table>	79	78	77	76	75	74	73	72	71	70	69	68		66	65	64	63	61	60	59	58	57	56			53	52	50						44	43	41	40	39	38	37		35	34		32	30	29		27	26				22	21	20	19	18	17				13	12				8	6	5		3	2	
79	78	77	76	75	74	73	72	71	70	69	68		66	65	64	63	61																																																																
60	59	58	57	56			53	52	50						44	43	41																																																																
40	39	38	37		35	34		32	30	29		27	26				22	21																																																															
20	19	18	17				13	12				8	6	5		3	2																																																																
AVAILABLE	NOT APPLICABLE	34566-2673	G	0	H	ST GRAY	<table border="1"> <tr><td>79</td><td>78</td><td>77</td><td>76</td><td>75</td><td>74</td><td>73</td><td>72</td><td>71</td><td>70</td><td>69</td><td>68</td><td></td><td>66</td><td>65</td><td>64</td><td>63</td><td>61</td></tr> <tr><td>60</td><td>59</td><td>58</td><td>57</td><td>56</td><td></td><td></td><td>53</td><td>52</td><td>50</td><td></td><td></td><td></td><td></td><td></td><td>44</td><td>43</td><td>41</td></tr> <tr><td>40</td><td>39</td><td>38</td><td>37</td><td></td><td>35</td><td>34</td><td></td><td>32</td><td>30</td><td>29</td><td></td><td>27</td><td>26</td><td></td><td></td><td></td><td>22</td><td>21</td></tr> <tr><td>20</td><td>19</td><td>18</td><td>17</td><td>16</td><td></td><td></td><td>13</td><td>12</td><td></td><td></td><td></td><td>8</td><td>6</td><td>5</td><td></td><td>3</td><td>2</td><td></td></tr> </table>	79	78	77	76	75	74	73	72	71	70	69	68		66	65	64	63	61	60	59	58	57	56			53	52	50						44	43	41	40	39	38	37		35	34		32	30	29		27	26				22	21	20	19	18	17	16			13	12				8	6	5		3	2	
79	78	77	76	75	74	73	72	71	70	69	68		66	65	64	63	61																																																																
60	59	58	57	56			53	52	50						44	43	41																																																																
40	39	38	37		35	34		32	30	29		27	26				22	21																																																															
20	19	18	17	16			13	12				8	6	5		3	2																																																																

ENTER DESCRIPTION IEC NO: UAU2014-0574 DRAWNS: SKRAJENDRANA 2013/10/08 CHKD: APPR: IKOSHY 2013/10/09 REV: 00	QUALITY SYMBOLS	GENERAL TOLERANCES (UNLESS SPECIFIED)	DIMENSION STYLE	SCALE	DESIGN UNITS	THIRD ANGLE PROJECTION
	▽=0	4 PLACES ± --- INCH	MM ONLY		METRIC	
	▽=0	3 PLACES ± --- INCH	DRAWN BY: SKRAJENDRANA 2011/02/14	DATE: 2011/02/14	TITLE: MX123	
	▽=0	2 PLACES ± --- INCH	CHECKED BY: MYANSLAMBROU 2011/02/14	DATE: 2011/02/14	HRNS CONN ASSY	
	1 PLACE ± --- INCH	0 PLACE ± --- INCH	APPROVED BY:	DATE:		
	ANGULAR ± --- °	DRAFT WHERE APPLICABLE MUST REMAIN WITHIN DIMENSIONS	MATERIAL NO:	DOCUMENT NO:		
			SEE BOM TABLE		SD-34566-001	SHEET NO. 31 OF 68
			THIS DRAWING CONTAINS INFORMATION THAT IS PROPRIETARY TO MOLEX INCORPORATED AND SHOULD NOT BE USED WITHOUT WRITTEN PERMISSION			

STATUS	GM PART #	MATERIAL #	PART/MATERIAL REVISION	WIRE DRESS OPTION	KEY OPTION	COLOR (TPA)	NUMBERS INDICATE CAVITIES OPEN FOR CIRCUITS																																																																	
AVAILABLE	NOT APPLICABLE	34566-2893	G	0	A	BLACK	<table border="1"> <tr><td>72</td><td></td><td>69</td><td>67</td><td>65</td><td>63</td><td></td><td>60</td><td></td><td>57</td><td>56</td><td></td><td>53</td></tr> <tr><td></td><td></td><td>49</td><td>47</td><td>46</td><td>44</td><td>43</td><td></td><td>40</td><td></td><td>37</td><td>36</td><td>35</td><td>33</td></tr> <tr><td></td><td>73</td><td></td><td>31</td><td>30</td><td>29</td><td>28</td><td></td><td>24</td><td></td><td>21</td><td>20</td><td></td><td>17</td></tr> <tr><td></td><td></td><td></td><td>16</td><td>15</td><td>14</td><td>13</td><td></td><td>11</td><td>10</td><td></td><td>5</td><td>4</td><td>3</td><td>2</td><td>1</td></tr> </table>	72		69	67	65	63		60		57	56		53			49	47	46	44	43		40		37	36	35	33		73		31	30	29	28		24		21	20		17				16	15	14	13		11	10		5	4	3	2	1								
72		69	67	65	63		60		57	56		53																																																												
		49	47	46	44	43		40		37	36	35	33																																																											
	73		31	30	29	28		24		21	20		17																																																											
			16	15	14	13		11	10		5	4	3	2	1																																																									
AVAILABLE	NOT APPLICABLE	34566-2913	G	0	B	ST GRY	<table border="1"> <tr><td></td><td></td><td>68</td><td>67</td><td></td><td>64</td><td></td><td></td><td></td><td>58</td><td></td><td></td><td></td><td></td><td></td><td></td></tr> <tr><td></td><td></td><td></td><td></td><td>46</td><td>45</td><td></td><td></td><td></td><td>38</td><td></td><td></td><td></td><td></td><td></td><td></td></tr> <tr><td></td><td>73</td><td></td><td>32</td><td>30</td><td>29</td><td>28</td><td>27</td><td></td><td></td><td>22</td><td></td><td></td><td></td><td></td><td>17</td></tr> <tr><td></td><td></td><td></td><td></td><td>15</td><td>14</td><td>13</td><td></td><td>10</td><td></td><td></td><td></td><td></td><td></td><td></td><td>1</td></tr> </table>			68	67		64				58											46	45				38								73		32	30	29	28	27			22					17					15	14	13		10							1	
		68	67		64				58																																																															
				46	45				38																																																															
	73		32	30	29	28	27			22					17																																																									
				15	14	13		10							1																																																									
AVAILABLE	NOT APPLICABLE	34566-2923	G	0	B	ST GRY	<table border="1"> <tr><td></td><td></td><td>68</td><td>67</td><td></td><td>64</td><td></td><td></td><td></td><td></td><td></td><td></td><td></td><td></td><td></td><td></td></tr> <tr><td></td><td></td><td></td><td></td><td>46</td><td>45</td><td></td><td></td><td></td><td></td><td></td><td></td><td></td><td></td><td></td><td></td></tr> <tr><td></td><td>73</td><td></td><td>32</td><td>30</td><td>29</td><td>28</td><td>27</td><td></td><td></td><td></td><td></td><td></td><td></td><td></td><td>17</td></tr> <tr><td></td><td></td><td></td><td></td><td>15</td><td>14</td><td>13</td><td></td><td>10</td><td></td><td></td><td></td><td></td><td></td><td></td><td></td></tr> </table>			68	67		64															46	45												73		32	30	29	28	27								17					15	14	13		10								
		68	67		64																																																																			
				46	45																																																																			
	73		32	30	29	28	27								17																																																									
				15	14	13		10																																																																
AVAILABLE	NOT APPLICABLE	34566-2933	G	0	A	BLACK	<table border="1"> <tr><td>72</td><td></td><td>69</td><td>67</td><td>65</td><td>63</td><td></td><td>60</td><td></td><td>57</td><td>56</td><td></td><td>53</td></tr> <tr><td></td><td></td><td>49</td><td>47</td><td>46</td><td>44</td><td>43</td><td></td><td>40</td><td></td><td>37</td><td>36</td><td>35</td><td>33</td></tr> <tr><td></td><td>73</td><td></td><td>31</td><td>30</td><td>29</td><td>28</td><td></td><td>24</td><td></td><td>21</td><td>20</td><td></td><td>17</td></tr> <tr><td></td><td></td><td></td><td>16</td><td>15</td><td>14</td><td>13</td><td></td><td>11</td><td>10</td><td></td><td>5</td><td>4</td><td>3</td><td>2</td><td>1</td></tr> </table>	72		69	67	65	63		60		57	56		53			49	47	46	44	43		40		37	36	35	33		73		31	30	29	28		24		21	20		17				16	15	14	13		11	10		5	4	3	2	1								
72		69	67	65	63		60		57	56		53																																																												
		49	47	46	44	43		40		37	36	35	33																																																											
	73		31	30	29	28		24		21	20		17																																																											
			16	15	14	13		11	10		5	4	3	2	1																																																									
AVAILABLE	NOT APPLICABLE	34566-2943	G	0	B	ST GRY	<table border="1"> <tr><td></td><td></td><td>68</td><td>67</td><td></td><td>64</td><td>63</td><td></td><td></td><td>59</td><td>57</td><td></td><td></td><td></td><td></td><td></td></tr> <tr><td></td><td></td><td></td><td></td><td>46</td><td>45</td><td>43</td><td></td><td></td><td>39</td><td>37</td><td></td><td></td><td></td><td></td><td></td></tr> <tr><td></td><td>73</td><td></td><td>32</td><td>30</td><td>29</td><td>28</td><td>27</td><td></td><td></td><td>21</td><td></td><td></td><td></td><td></td><td></td></tr> <tr><td></td><td></td><td></td><td></td><td></td><td></td><td></td><td></td><td>10</td><td></td><td></td><td>6</td><td>5</td><td>4</td><td>3</td><td></td></tr> </table>			68	67		64	63			59	57										46	45	43			39	37							73		32	30	29	28	27			21														10			6	5	4	3		
		68	67		64	63			59	57																																																														
				46	45	43			39	37																																																														
	73		32	30	29	28	27			21																																																														
								10			6	5	4	3																																																										
AVAILABLE	NOT APPLICABLE	34566-2953	G	0	B	ST GRY	<table border="1"> <tr><td></td><td></td><td>68</td><td>67</td><td></td><td>64</td><td>63</td><td></td><td></td><td>59</td><td></td><td></td><td></td><td></td><td></td><td>34</td></tr> <tr><td></td><td></td><td></td><td></td><td>46</td><td>45</td><td>43</td><td></td><td></td><td>39</td><td></td><td></td><td></td><td></td><td></td><td></td></tr> <tr><td></td><td>73</td><td></td><td>32</td><td>30</td><td>29</td><td>28</td><td>27</td><td></td><td></td><td></td><td></td><td></td><td></td><td></td><td></td></tr> <tr><td></td><td></td><td></td><td></td><td></td><td></td><td></td><td></td><td>10</td><td></td><td></td><td>6</td><td>5</td><td>4</td><td>3</td><td></td></tr> </table>			68	67		64	63			59						34					46	45	43			39								73		32	30	29	28	27																	10			6	5	4	3		
		68	67		64	63			59						34																																																									
				46	45	43			39																																																															
	73		32	30	29	28	27																																																																	
								10			6	5	4	3																																																										
AVAILABLE	NOT APPLICABLE	34566-2963	G	0	H	ST GRY	<table border="1"> <tr><td></td><td>79</td><td></td><td></td><td>74</td><td>73</td><td>72</td><td>71</td><td>69</td><td>68</td><td>67</td><td></td><td>64</td><td>62</td><td>61</td></tr> <tr><td></td><td>59</td><td></td><td></td><td>54</td><td>53</td><td>52</td><td></td><td>49</td><td>48</td><td>47</td><td></td><td></td><td>42</td><td>41</td></tr> <tr><td></td><td></td><td>38</td><td></td><td></td><td>33</td><td></td><td></td><td>29</td><td>27</td><td>25</td><td></td><td></td><td></td><td>21</td></tr> <tr><td></td><td></td><td></td><td></td><td>15</td><td>14</td><td></td><td>11</td><td>10</td><td>9</td><td>8</td><td>7</td><td></td><td></td><td></td></tr> </table>		79			74	73	72	71	69	68	67		64	62	61		59			54	53	52		49	48	47			42	41			38			33			29	27	25				21					15	14		11	10	9	8	7								
	79			74	73	72	71	69	68	67		64	62	61																																																										
	59			54	53	52		49	48	47			42	41																																																										
		38			33			29	27	25				21																																																										
				15	14		11	10	9	8	7																																																													
AVAILABLE	NOT APPLICABLE	34566-2973	G	0	G	BLUE	<table border="1"> <tr><td>80</td><td>78</td><td>77</td><td>75</td><td>74</td><td>73</td><td>72</td><td>70</td><td>69</td><td>67</td><td>65</td><td>64</td><td>63</td><td>62</td><td></td><td></td></tr> <tr><td>60</td><td>58</td><td>57</td><td>55</td><td>54</td><td>52</td><td>51</td><td>50</td><td>49</td><td>47</td><td>45</td><td></td><td></td><td></td><td></td><td></td></tr> <tr><td>40</td><td>38</td><td>37</td><td></td><td></td><td>33</td><td>32</td><td>31</td><td></td><td></td><td>27</td><td>26</td><td>25</td><td>24</td><td></td><td></td></tr> <tr><td>20</td><td>18</td><td>17</td><td></td><td></td><td></td><td></td><td></td><td>10</td><td>9</td><td>8</td><td>6</td><td>5</td><td></td><td>3</td><td>2</td><td>1</td></tr> </table>	80	78	77	75	74	73	72	70	69	67	65	64	63	62			60	58	57	55	54	52	51	50	49	47	45						40	38	37			33	32	31			27	26	25	24			20	18	17						10	9	8	6	5		3	2	1
80	78	77	75	74	73	72	70	69	67	65	64	63	62																																																											
60	58	57	55	54	52	51	50	49	47	45																																																														
40	38	37			33	32	31			27	26	25	24																																																											
20	18	17						10	9	8	6	5		3	2	1																																																								

ENTER DESCRIPTION IEC NO: UAU2014-0574 DRAWN BY: SKRA JENDRANA 2013/10/08 CHKD: APPR: IKOSHY 2013/10/09 REV: GO	QUALITY SYMBOLS	GENERAL TOLERANCES (UNLESS SPECIFIED)	DIMENSION STYLE	SCALE	DESIGN UNITS	THIRD ANGLE PROJECTION
	▽=0	4 PLACES ±--- INCH	MM ONLY		METRIC	
	▽=0	3 PLACES ±--- INCH				
	▽=0	2 PLACES ±--- INCH				
	ANGULAR ±---°					
	DRAFT WHERE APPLICABLE MUST REMAIN WITHIN DIMENSIONS					
			DRAWN BY: SKRA JENDRANA 2011/02/14	DATE	TITLE	
			CHECKED BY: MVANSLAMBROU 2011/02/14	DATE		
			APPROVED BY:	DATE		
			MATERIAL NO.	DOCUMENT NO.		
			SEE BOM TABLE	SD-34566-001		
			THIS DRAWING CONTAINS INFORMATION THAT IS PROPRIETARY TO MOLEX INCORPORATED AND SHOULD NOT BE USED WITHOUT WRITTEN PERMISSION			
						SHEET NO. 34 OF 68

STATUS	GM PART #	MATERIAL #	PART/MATERIAL REVISION	WIRE DRESS OPTION	KEY OPTION	COLOR (TPA)	NUMBERS INDICATE CAVITIES OPEN FOR CIRCUITS																																																																																																				
AVAILABLE	NOT APPLICABLE	34566-9913	G	0	A	BLACK	<table border="1"> <tr><td>72</td><td>71</td><td></td><td>68</td><td>67</td><td>66</td><td>65</td><td>64</td><td></td><td></td><td>59</td><td></td><td></td><td></td><td></td><td></td><td></td><td></td><td></td><td></td></tr> <tr><td></td><td></td><td>50</td><td>48</td><td>47</td><td>46</td><td>45</td><td></td><td></td><td></td><td>40</td><td>39</td><td>38</td><td></td><td></td><td></td><td></td><td></td><td></td><td></td></tr> <tr><td></td><td></td><td></td><td></td><td></td><td>31</td><td>30</td><td></td><td></td><td></td><td>25</td><td>24</td><td>22</td><td>21</td><td>20</td><td></td><td></td><td></td><td></td><td>17</td></tr> <tr><td></td><td></td><td></td><td></td><td></td><td></td><td>14</td><td></td><td></td><td></td><td>9</td><td>7</td><td>6</td><td>5</td><td>4</td><td></td><td></td><td></td><td></td><td>2</td></tr> <tr><td></td><td></td><td></td><td></td><td></td><td></td><td></td><td></td><td></td><td></td><td></td><td></td><td></td><td></td><td></td><td></td><td></td><td></td><td></td><td>1</td></tr> </table>	72	71		68	67	66	65	64			59												50	48	47	46	45				40	39	38													31	30				25	24	22	21	20					17							14				9	7	6	5	4					2																				1
72	71		68	67	66	65	64			59																																																																																																	
		50	48	47	46	45				40	39	38																																																																																															
					31	30				25	24	22	21	20					17																																																																																								
						14				9	7	6	5	4					2																																																																																								
																			1																																																																																								
AVAILABLE	NOT APPLICABLE	34566-9923	G	0	A	BLACK	<table border="1"> <tr><td>72</td><td>71</td><td></td><td></td><td>67</td><td>66</td><td></td><td></td><td></td><td></td><td>62</td><td>61</td><td>60</td><td></td><td>57</td><td>55</td><td>54</td><td></td><td></td><td></td></tr> <tr><td></td><td></td><td>51</td><td></td><td>48</td><td>46</td><td>45</td><td>44</td><td>43</td><td>42</td><td></td><td></td><td>39</td><td></td><td></td><td></td><td>35</td><td>33</td><td></td><td></td></tr> <tr><td></td><td></td><td></td><td></td><td></td><td></td><td></td><td></td><td></td><td></td><td>26</td><td>25</td><td>24</td><td></td><td></td><td></td><td></td><td></td><td></td><td></td></tr> <tr><td></td><td></td><td></td><td></td><td></td><td></td><td></td><td></td><td></td><td></td><td></td><td></td><td>8</td><td>7</td><td>6</td><td>5</td><td>4</td><td>3</td><td>2</td><td></td></tr> <tr><td></td><td></td><td></td><td></td><td></td><td></td><td></td><td></td><td></td><td></td><td></td><td></td><td></td><td></td><td></td><td></td><td></td><td></td><td></td><td></td></tr> </table>	72	71			67	66					62	61	60		57	55	54						51		48	46	45	44	43	42			39				35	33													26	25	24																				8	7	6	5	4	3	2																					
72	71			67	66					62	61	60		57	55	54																																																																																											
		51		48	46	45	44	43	42			39				35	33																																																																																										
										26	25	24																																																																																															
												8	7	6	5	4	3	2																																																																																									
AVAILABLE	NOT APPLICABLE	34566-9933	G	0	B	ST GRY	<table border="1"> <tr><td></td><td></td><td></td><td>69</td><td></td><td></td><td>65</td><td>64</td><td>63</td><td></td><td></td><td></td><td></td><td></td><td></td><td></td><td></td><td></td><td></td><td></td></tr> <tr><td></td><td></td><td></td><td>49</td><td></td><td></td><td>45</td><td>44</td><td>43</td><td></td><td></td><td></td><td></td><td></td><td></td><td></td><td></td><td></td><td></td><td></td></tr> <tr><td></td><td></td><td></td><td></td><td></td><td></td><td></td><td></td><td></td><td></td><td></td><td></td><td></td><td></td><td>22</td><td>21</td><td>20</td><td>19</td><td>18</td><td>17</td></tr> <tr><td></td><td></td><td></td><td></td><td></td><td></td><td></td><td></td><td>12</td><td>11</td><td></td><td></td><td></td><td></td><td>6</td><td>5</td><td>4</td><td>3</td><td>2</td><td>1</td></tr> <tr><td></td><td></td><td></td><td></td><td></td><td></td><td></td><td></td><td></td><td></td><td></td><td></td><td></td><td></td><td></td><td></td><td></td><td></td><td></td><td></td></tr> </table>				69			65	64	63															49			45	44	43																										22	21	20	19	18	17									12	11					6	5	4	3	2	1																				
			69			65	64	63																																																																																																			
			49			45	44	43																																																																																																			
														22	21	20	19	18	17																																																																																								
								12	11					6	5	4	3	2	1																																																																																								
AVAILABLE	NOT APPLICABLE	34566-9943	G	0	C	BLUE	<table border="1"> <tr><td></td><td>71</td><td>69</td><td></td><td></td><td>65</td><td>64</td><td></td><td>61</td><td>60</td><td>58</td><td>56</td><td>55</td><td>54</td><td></td><td></td><td></td><td></td><td></td><td></td></tr> <tr><td></td><td></td><td>50</td><td>49</td><td></td><td>45</td><td>43</td><td>41</td><td></td><td></td><td></td><td>37</td><td>36</td><td>35</td><td></td><td></td><td></td><td></td><td></td><td></td></tr> <tr><td></td><td></td><td></td><td></td><td>31</td><td>29</td><td>28</td><td></td><td></td><td></td><td>24</td><td>23</td><td></td><td></td><td>19</td><td>18</td><td>17</td><td></td><td></td><td></td></tr> <tr><td></td><td></td><td></td><td></td><td></td><td>16</td><td></td><td>13</td><td>12</td><td>11</td><td></td><td>8</td><td>7</td><td></td><td></td><td>3</td><td>2</td><td>1</td><td></td><td></td></tr> <tr><td></td><td></td><td></td><td></td><td></td><td></td><td></td><td></td><td></td><td></td><td></td><td></td><td></td><td></td><td></td><td></td><td></td><td></td><td></td><td></td></tr> </table>		71	69			65	64		61	60	58	56	55	54									50	49		45	43	41				37	36	35											31	29	28				24	23			19	18	17									16		13	12	11		8	7			3	2	1																						
	71	69			65	64		61	60	58	56	55	54																																																																																														
		50	49		45	43	41				37	36	35																																																																																														
				31	29	28				24	23			19	18	17																																																																																											
					16		13	12	11		8	7			3	2	1																																																																																										
AVAILABLE	NOT APPLICABLE	34566-9953	G	0	A	BLACK	<table border="1"> <tr><td></td><td></td><td></td><td>67</td><td></td><td></td><td></td><td></td><td>62</td><td>60</td><td></td><td>57</td><td>55</td><td></td><td></td><td></td><td></td><td></td><td></td><td></td></tr> <tr><td></td><td></td><td>51</td><td></td><td>48</td><td>46</td><td>45</td><td>44</td><td>43</td><td></td><td>39</td><td></td><td></td><td>35</td><td></td><td></td><td></td><td></td><td></td><td></td></tr> <tr><td></td><td></td><td></td><td></td><td></td><td></td><td></td><td></td><td></td><td></td><td>25</td><td></td><td></td><td></td><td></td><td></td><td></td><td></td><td></td><td></td></tr> <tr><td></td><td></td><td></td><td></td><td></td><td></td><td></td><td></td><td></td><td></td><td></td><td>7</td><td>6</td><td>5</td><td>4</td><td>3</td><td>2</td><td></td><td></td><td></td></tr> <tr><td></td><td></td><td></td><td></td><td></td><td></td><td></td><td></td><td></td><td></td><td></td><td></td><td></td><td></td><td></td><td></td><td></td><td></td><td></td><td></td></tr> </table>				67					62	60		57	55										51		48	46	45	44	43		39			35																	25																					7	6	5	4	3	2																							
			67					62	60		57	55																																																																																															
		51		48	46	45	44	43		39			35																																																																																														
										25																																																																																																	
											7	6	5	4	3	2																																																																																											
AVAILABLE	NOT APPLICABLE	34566-9963	G	0	B	ST GRY	<table border="1"> <tr><td></td><td></td><td></td><td>68</td><td>67</td><td></td><td>64</td><td>63</td><td></td><td></td><td></td><td>58</td><td></td><td>55</td><td></td><td></td><td></td><td></td><td></td><td></td></tr> <tr><td></td><td></td><td></td><td></td><td></td><td>46</td><td>45</td><td>43</td><td></td><td></td><td></td><td>38</td><td></td><td>35</td><td></td><td></td><td></td><td></td><td></td><td></td></tr> <tr><td></td><td></td><td></td><td></td><td>32</td><td>30</td><td>29</td><td>28</td><td>27</td><td></td><td></td><td>22</td><td></td><td>19</td><td></td><td>17</td><td></td><td></td><td></td><td></td></tr> <tr><td></td><td></td><td></td><td></td><td></td><td>15</td><td>13</td><td></td><td>10</td><td></td><td></td><td></td><td></td><td></td><td></td><td></td><td></td><td></td><td></td><td>1</td></tr> <tr><td></td><td></td><td></td><td></td><td></td><td></td><td></td><td></td><td></td><td></td><td></td><td></td><td></td><td></td><td></td><td></td><td></td><td></td><td></td><td></td></tr> </table>				68	67		64	63				58		55												46	45	43				38		35											32	30	29	28	27			22		19		17										15	13		10											1																				
			68	67		64	63				58		55																																																																																														
					46	45	43				38		35																																																																																														
				32	30	29	28	27			22		19		17																																																																																												
					15	13		10											1																																																																																								
AVAILABLE	NOT APPLICABLE	34566-9973	G	0	B	ST GRY	<table border="1"> <tr><td></td><td></td><td></td><td>68</td><td>67</td><td></td><td>64</td><td>63</td><td></td><td></td><td></td><td>58</td><td></td><td></td><td></td><td></td><td></td><td></td><td></td><td></td></tr> <tr><td></td><td></td><td></td><td></td><td></td><td>46</td><td>45</td><td>43</td><td></td><td></td><td></td><td>38</td><td></td><td></td><td></td><td></td><td></td><td></td><td></td><td></td></tr> <tr><td></td><td></td><td></td><td></td><td>32</td><td>30</td><td>29</td><td>28</td><td>27</td><td></td><td></td><td>22</td><td></td><td></td><td></td><td></td><td></td><td></td><td></td><td>17</td></tr> <tr><td></td><td></td><td></td><td></td><td></td><td>15</td><td>13</td><td></td><td>10</td><td></td><td></td><td></td><td></td><td></td><td></td><td></td><td></td><td></td><td></td><td></td></tr> <tr><td></td><td></td><td></td><td></td><td></td><td></td><td></td><td></td><td></td><td></td><td></td><td></td><td></td><td></td><td></td><td></td><td></td><td></td><td></td><td></td></tr> </table>				68	67		64	63				58														46	45	43				38													32	30	29	28	27			22								17						15	13		10																															
			68	67		64	63				58																																																																																																
					46	45	43				38																																																																																																
				32	30	29	28	27			22								17																																																																																								
					15	13		10																																																																																																			

ENTER DESCRIPTION IEC NO: UAU2014-0574 DRAWN BY: SKRAJENDRANA 2013/10/08 CHKD: SKRAJENDRANA 2013/10/08 APPR: IKOSHY 2013/10/09 GO	QUALITY SYMBOLS ∇=0 ∇=0 ∇=0	GENERAL TOLERANCES (UNLESS SPECIFIED) mm INCH 4 PLACES #--- #--- 3 PLACES #--- #--- 2 PLACES #--- #--- 1 PLACE #--- #--- 0 PLACE #--- #--- ANGULAR ±---° DRAFT WHERE APPLICABLE MUST REMAIN WITHIN DIMENSIONS	DIMENSION STYLE MM ONLY	SCALE DESIGN UNITS METRIC	THIRD ANGLE PROJECTION
	DRAWN BY: SKRAJENDRANA 2011/02/14 CHECKED BY: DATE MVANSLAMBROU 2011/02/14 APPROVED BY: DATE		TITLE MX123 66/73/80CKT HRNS CONN ASSY		MATERIAL NO. SD-34566-001
	DOCUMENT NO. SD-34566-001		SHEET NO. 35 OF 68		SIZE D
	THIS DRAWING CONTAINS INFORMATION THAT IS PROPRIETARY TO MOLEX INCORPORATED AND SHOULD NOT BE USED WITHOUT WRITTEN PERMISSION				

STATUS	GM PART #	MATERIAL #	PART/MATERIAL REVISION	WIRE DRESS OPTION	KEY OPTION	COLOR (TPA)	NUMBERS INDICATE CAVITIES OPEN FOR CIRCUITS																																																																																								
AVAILABLE	NOT APPLICABLE	34566-2983	G	9	A	BLACK	<table border="1"> <tr><td></td><td></td><td>70</td><td>69</td><td></td><td></td><td></td><td></td><td></td><td></td><td>63</td><td>62</td><td>61</td><td></td><td></td><td>58</td><td>57</td><td>56</td><td>55</td><td>54</td><td>53</td></tr> <tr><td>52</td><td>51</td><td></td><td>49</td><td></td><td></td><td></td><td></td><td></td><td></td><td>44</td><td>43</td><td>42</td><td>41</td><td></td><td></td><td>37</td><td>36</td><td></td><td>34</td><td></td></tr> <tr><td></td><td></td><td></td><td></td><td>73</td><td></td><td></td><td></td><td></td><td></td><td></td><td></td><td></td><td></td><td></td><td></td><td></td><td></td><td></td><td>19</td><td>18</td><td>17</td></tr> <tr><td></td><td></td><td></td><td></td><td></td><td></td><td></td><td></td><td></td><td></td><td></td><td></td><td></td><td></td><td></td><td></td><td></td><td></td><td></td><td>3</td><td>2</td><td>1</td></tr> </table>			70	69							63	62	61			58	57	56	55	54	53	52	51		49							44	43	42	41			37	36		34						73															19	18	17																				3	2	1		
		70	69							63	62	61			58	57	56	55	54	53																																																																											
52	51		49							44	43	42	41			37	36		34																																																																												
				73															19	18	17																																																																										
																			3	2	1																																																																										
AVAILABLE	NOT APPLICABLE	34566-2993	G	9	B	ST GRY	<table border="1"> <tr><td>72</td><td>71</td><td>70</td><td></td><td>68</td><td>67</td><td>66</td><td></td><td></td><td></td><td>62</td><td>61</td><td>60</td><td>59</td><td>58</td><td>57</td><td>56</td><td>55</td><td>54</td><td>53</td></tr> <tr><td>52</td><td>51</td><td>50</td><td></td><td>48</td><td>47</td><td>46</td><td></td><td></td><td></td><td>42</td><td>41</td><td>40</td><td>39</td><td>38</td><td>37</td><td>36</td><td>35</td><td>34</td><td>33</td></tr> <tr><td></td><td></td><td></td><td></td><td></td><td></td><td></td><td></td><td></td><td></td><td></td><td></td><td></td><td></td><td></td><td></td><td></td><td></td><td></td><td></td><td></td></tr> <tr><td></td><td></td><td></td><td></td><td></td><td></td><td></td><td></td><td></td><td></td><td></td><td></td><td></td><td></td><td></td><td></td><td></td><td></td><td></td><td></td><td></td></tr> </table>	72	71	70		68	67	66				62	61	60	59	58	57	56	55	54	53	52	51	50		48	47	46				42	41	40	39	38	37	36	35	34	33																																																
72	71	70		68	67	66				62	61	60	59	58	57	56	55	54	53																																																																												
52	51	50		48	47	46				42	41	40	39	38	37	36	35	34	33																																																																												
AVAILABLE	NOT APPLICABLE	34566-3013	G	9	C	BLUE	<table border="1"> <tr><td>72</td><td>71</td><td>70</td><td>69</td><td>68</td><td>67</td><td>66</td><td></td><td></td><td></td><td>63</td><td>62</td><td></td><td>59</td><td></td><td>57</td><td>56</td><td>55</td><td></td><td>53</td></tr> <tr><td>52</td><td>51</td><td></td><td></td><td></td><td></td><td></td><td></td><td></td><td></td><td>46</td><td>44</td><td></td><td>42</td><td>40</td><td>39</td><td>38</td><td></td><td></td><td>34</td><td>33</td></tr> <tr><td></td><td></td><td></td><td></td><td></td><td></td><td></td><td></td><td></td><td></td><td></td><td></td><td></td><td></td><td></td><td></td><td></td><td></td><td></td><td></td><td></td></tr> <tr><td></td><td></td><td></td><td></td><td></td><td></td><td></td><td></td><td></td><td></td><td></td><td></td><td></td><td></td><td></td><td></td><td></td><td></td><td></td><td></td><td></td></tr> </table>	72	71	70	69	68	67	66				63	62		59		57	56	55		53	52	51									46	44		42	40	39	38			34	33																																															
72	71	70	69	68	67	66				63	62		59		57	56	55		53																																																																												
52	51									46	44		42	40	39	38			34	33																																																																											
AVAILABLE	NOT APPLICABLE	34566-3023	G	0	G	BLUE	<table border="1"> <tr><td></td><td>79</td><td></td><td></td><td>76</td><td></td><td></td><td></td><td></td><td></td><td>71</td><td></td><td></td><td>68</td><td>66</td><td></td><td></td><td></td><td></td><td></td><td>61</td></tr> <tr><td></td><td>59</td><td></td><td></td><td>56</td><td></td><td></td><td>53</td><td></td><td></td><td></td><td></td><td></td><td>48</td><td>46</td><td></td><td>44</td><td>43</td><td>42</td><td>41</td><td></td></tr> <tr><td></td><td>39</td><td></td><td></td><td>36</td><td>35</td><td>34</td><td></td><td></td><td></td><td></td><td></td><td>30</td><td>29</td><td>28</td><td></td><td></td><td></td><td></td><td>23</td><td>22</td><td>21</td></tr> <tr><td></td><td>19</td><td></td><td></td><td>16</td><td>15</td><td>14</td><td>13</td><td>12</td><td>11</td><td></td><td></td><td></td><td>7</td><td></td><td></td><td>4</td><td></td><td></td><td></td><td></td><td></td></tr> </table>		79			76						71			68	66						61		59			56			53						48	46		44	43	42	41			39			36	35	34						30	29	28					23	22	21		19			16	15	14	13	12	11				7			4							
	79			76						71			68	66						61																																																																											
	59			56			53						48	46		44	43	42	41																																																																												
	39			36	35	34						30	29	28					23	22	21																																																																										
	19			16	15	14	13	12	11				7			4																																																																															
AVAILABLE	NOT APPLICABLE	34566-3033	G	0	H	ST GRY	<table border="1"> <tr><td>80</td><td>78</td><td>77</td><td>76</td><td>75</td><td></td><td></td><td></td><td></td><td></td><td>70</td><td></td><td></td><td></td><td></td><td>66</td><td>65</td><td></td><td>63</td><td></td><td></td></tr> <tr><td>60</td><td>58</td><td>57</td><td>56</td><td>55</td><td></td><td></td><td></td><td></td><td></td><td>51</td><td>50</td><td></td><td></td><td></td><td>46</td><td>45</td><td>44</td><td>43</td><td></td><td></td></tr> <tr><td>40</td><td>39</td><td></td><td>37</td><td>36</td><td>35</td><td>34</td><td></td><td></td><td></td><td>32</td><td>31</td><td>30</td><td></td><td>28</td><td>26</td><td></td><td>24</td><td>23</td><td>22</td><td></td></tr> <tr><td>20</td><td>19</td><td>18</td><td>17</td><td>16</td><td></td><td></td><td></td><td></td><td></td><td></td><td></td><td></td><td></td><td></td><td>6</td><td>5</td><td>4</td><td>3</td><td>2</td><td>1</td></tr> </table>	80	78	77	76	75						70					66	65		63			60	58	57	56	55						51	50				46	45	44	43			40	39		37	36	35	34				32	31	30		28	26		24	23	22		20	19	18	17	16											6	5	4	3	2	1				
80	78	77	76	75						70					66	65		63																																																																													
60	58	57	56	55						51	50				46	45	44	43																																																																													
40	39		37	36	35	34				32	31	30		28	26		24	23	22																																																																												
20	19	18	17	16											6	5	4	3	2	1																																																																											
AVAILABLE	NOT APPLICABLE	34566-3043	G	0	C	BLUE	<table border="1"> <tr><td>72</td><td>70</td><td></td><td>68</td><td></td><td>66</td><td></td><td></td><td></td><td></td><td>63</td><td>62</td><td></td><td>59</td><td></td><td>57</td><td></td><td></td><td></td><td></td><td>53</td></tr> <tr><td>52</td><td>51</td><td></td><td>48</td><td>47</td><td>46</td><td></td><td></td><td></td><td></td><td>44</td><td>42</td><td></td><td>40</td><td>39</td><td></td><td></td><td></td><td></td><td></td><td>34</td><td>33</td></tr> <tr><td></td><td></td><td></td><td></td><td></td><td></td><td></td><td></td><td></td><td></td><td></td><td></td><td></td><td></td><td></td><td></td><td></td><td></td><td></td><td></td><td></td><td></td></tr> <tr><td></td><td></td><td></td><td></td><td></td><td></td><td></td><td></td><td></td><td></td><td></td><td></td><td></td><td></td><td></td><td></td><td></td><td></td><td></td><td></td><td></td><td></td></tr> </table>	72	70		68		66					63	62		59		57					53	52	51		48	47	46					44	42		40	39						34	33																																													
72	70		68		66					63	62		59		57					53																																																																											
52	51		48	47	46					44	42		40	39						34	33																																																																										
AVAILABLE	NOT APPLICABLE	34566-3053	G	0	C	BLUE	<table border="1"> <tr><td>72</td><td>70</td><td></td><td>68</td><td></td><td>66</td><td></td><td></td><td></td><td></td><td>63</td><td>62</td><td></td><td>59</td><td></td><td>57</td><td></td><td></td><td></td><td></td><td>53</td></tr> <tr><td>52</td><td>51</td><td></td><td>48</td><td>47</td><td>46</td><td></td><td></td><td></td><td></td><td>44</td><td>42</td><td></td><td>40</td><td>39</td><td>38</td><td></td><td></td><td></td><td></td><td>34</td><td>33</td></tr> <tr><td></td><td></td><td></td><td></td><td></td><td></td><td></td><td></td><td></td><td></td><td></td><td></td><td></td><td></td><td></td><td></td><td></td><td></td><td></td><td></td><td></td><td></td></tr> <tr><td></td><td></td><td></td><td></td><td></td><td></td><td></td><td></td><td></td><td></td><td></td><td></td><td></td><td></td><td></td><td></td><td></td><td></td><td></td><td></td><td></td><td></td></tr> </table>	72	70		68		66					63	62		59		57					53	52	51		48	47	46					44	42		40	39	38					34	33																																													
72	70		68		66					63	62		59		57					53																																																																											
52	51		48	47	46					44	42		40	39	38					34	33																																																																										
AVAILABLE	NOT APPLICABLE	34566-3063	G	0	A	BLACK	<table border="1"> <tr><td></td><td>71</td><td></td><td>69</td><td></td><td></td><td></td><td></td><td></td><td></td><td>65</td><td>64</td><td>63</td><td></td><td></td><td>60</td><td>58</td><td>57</td><td>56</td><td>55</td><td>54</td><td>53</td></tr> <tr><td>52</td><td>51</td><td></td><td>49</td><td></td><td></td><td></td><td></td><td></td><td></td><td>45</td><td>44</td><td>43</td><td>42</td><td>41</td><td></td><td></td><td>37</td><td>36</td><td>35</td><td>34</td><td>33</td></tr> <tr><td></td><td></td><td></td><td></td><td></td><td></td><td></td><td></td><td></td><td></td><td></td><td></td><td></td><td></td><td></td><td></td><td></td><td></td><td></td><td></td><td>19</td><td>18</td></tr> <tr><td></td><td></td><td></td><td></td><td></td><td></td><td></td><td></td><td></td><td></td><td></td><td></td><td></td><td></td><td></td><td></td><td></td><td></td><td></td><td></td><td>3</td><td></td></tr> </table>		71		69							65	64	63			60	58	57	56	55	54	53	52	51		49							45	44	43	42	41			37	36	35	34	33																					19	18																					3	
	71		69							65	64	63			60	58	57	56	55	54	53																																																																										
52	51		49							45	44	43	42	41			37	36	35	34	33																																																																										
																				19	18																																																																										
																				3																																																																											

ENTER DESCRIPTION IEC NO: UAU2014-0574 DRAWN: SKRAJENDRANA 2013/10/08 CHKD: APPR: WOSHY 2013/10/09 REV:	QUALITY SYMBOLS	GENERAL TOLERANCES (UNLESS SPECIFIED)	DIMENSION STYLE	SCALE	DESIGN UNITS	THIRD ANGLE PROJECTION	
	$\nabla=0$ $\nabla=0$ $\nabla=0$	4 PLACES ±---+--- 3 PLACES ±---+--- 2 PLACES ±---+--- 1 PLACE ±---+--- 0 PLACE ±---+---	mm INCH ±---+--- ±---+--- ±---+--- ±---+---	MM ONLY DRAWN BY: SKRAJENDRANA 2011/02/14 CHECKED BY: MYANSLAMBROU 2011/02/14 APPROVED BY:	DATE	METRIC	
	ANGULAR ±---+--- DRAFT WHERE APPLICABLE MUST REMAIN WITHIN DIMENSIONS	SEE BOM TABLE	MATERIAL NO. DOCUMENT NO.	TITLE MX123 66/73/80CKT HRNS CONN ASSY molex SD-34566-001	SHEET NO. 36 OF 68		
	THIS DRAWING CONTAINS INFORMATION THAT IS PROPRIETARY TO MOLEX INCORPORATED AND SHOULD NOT BE USED WITHOUT WRITTEN PERMISSION						

STATUS	GM PART #	MATERIAL #	PART/MATERIAL REVISION	WIRE DRESS OPTION	KEY OPTION	COLOR (TPA)	NUMBERS INDICATE CAVITIES OPEN FOR CIRCUITS															
AVAILABLE	NOT APPLICABLE	34566-3073	G	0	A	BLACK	71	69			65	64	63		60		57	56	55	54	53	
							52	51	49			45	44	43	42	41		37	36	35	34	33
							73			32	30		28	26		23				19	18	
										16			12	10		8	7	6			3	
AVAILABLE	NOT APPLICABLE	34566-3083	G	0	A	BLACK	71	69			65	64	63		60		58	57	56	55	54	53
							52	51	49			45	44	43	42	41		37	36	35	34	33
							73			32	30		28	26						19	18	
										16			11	10							3	
AVAILABLE	NOT APPLICABLE	34566-3093	G	0	A	BLACK	71	69			64	63	62		60		57	56	55	54	53	
							52	51	49			45	44	43	42	41		37	36	35	34	33
							73			32	30		28	26		23				19	18	
										16			12	10							3	
AVAILABLE	NOT APPLICABLE	34566-3113	G	0	A	BLACK	71	69			65	64	63		60		57	56	55	54	53	
							52	51	49			45	44	43	42	41		37	36	35	34	33
							73			32	30		28	26		23	21			19	18	
										16			12	10		8		5			3	
AVAILABLE	NOT APPLICABLE	34566-3123	G	0	B	ST GRAY	72	70	68	66					60	59				55	54	53
							52	50	48	46					40	39				35	34	33
							73			32	31	30	29	28	27	26	25	24				
										16				10	9	8						
AVAILABLE	NOT APPLICABLE	34566-3133	G	0	C	BLUE	72	70	68	67	66			63	62		59	57			53	
							52	51	48	47	46		44	42	40	39					34	33
							73			32	30			26	25		22	21	20			
										15	14			10	9		6	5	4			
AVAILABLE	NOT APPLICABLE	34566-3143	G	0	C	BLUE	72	70			66			63	62		59	57			53	
							52	51			46	44		42	40	39		37	36		34	33
							73			32	30			26	25		22	21				
										15	14			10	9		6					
AVAILABLE	NOT APPLICABLE	34566-3153	G	0	A	BLACK		70	69								58	56		54		
							52	51	49	47			44	43	42	41				36	34	
							73			32			28	26						19	18	
										16			12	10							3	

ENTER DESCRIPTION IEC NO: UAU2014-0574 DRAWN BY: SKRAJENDRANA CHKO: MYANSLAMBROU APPR: IKOSHY REV: 2013/10/09	QUALITY SYMBOLS ∇=0 ∇=0 ∇=0	GENERAL TOLERANCES (UNLESS SPECIFIED): 4 PLACES ±---+--- 3 PLACES ±---+--- 2 PLACES ±---+--- 1 PLACE ±---+--- 0 PLACE ±---+---	DIMENSION STYLE MM ONLY	SCALE METRIC	DESIGN UNITS METRIC	THIRD ANGLE PROJECTION
	ANGULAR ±---° DRAFT WHERE APPLICABLE MUST REMAIN WITHIN DIMENSIONS	DRAWN BY: SKRAJENDRANA DATE: 2011/02/14 CHECKED BY: MYANSLAMBROU DATE: 2011/02/14 APPROVED BY:	MATERIAL NO. SEE BOM TABLE	DOCUMENT NO. SD-34566-001	SHEET NO. 37 OF 68	
	MX123 66/73/80CKT HRNS CONN ASSY molex					
	THIS DRAWING CONTAINS INFORMATION THAT IS PROPRIETARY TO MOLEX INCORPORATED AND SHOULD NOT BE USED WITHOUT WRITTEN PERMISSION					

STATUS	GM PART #	MATERIAL #	PART/MATERIAL REVISION	WIRE DRESS OPTION	KEY OPTION	COLOR (TPA)	NUMBERS INDICATE CAVITIES OPEN FOR CIRCUITS																																																																								
AVAILABLE	NOT APPLICABLE	34566-3163	G	0	C	BLUE	<table border="1"> <tr><td>72</td><td>70</td><td></td><td></td><td></td><td></td><td>63</td><td>62</td><td></td><td></td><td>59</td><td>57</td><td>56</td><td>55</td><td>53</td></tr> <tr><td>52</td><td>51</td><td></td><td></td><td></td><td></td><td>46</td><td>44</td><td>42</td><td>40</td><td>39</td><td>37</td><td>36</td><td>34</td><td>33</td></tr> <tr><td colspan="2">73</td><td></td><td></td><td>32</td><td></td><td>30</td><td></td><td>26</td><td>25</td><td></td><td>22</td><td>21</td><td>19</td><td>18</td></tr> <tr><td colspan="2"></td><td></td><td></td><td>15</td><td></td><td>14</td><td></td><td>10</td><td>9</td><td></td><td>6</td><td></td><td>3</td><td></td></tr> </table>	72	70					63	62			59	57	56	55	53	52	51					46	44	42	40	39	37	36	34	33	73				32		30		26	25		22	21	19	18					15		14		10	9		6		3													
72	70					63	62			59	57	56	55	53																																																																	
52	51					46	44	42	40	39	37	36	34	33																																																																	
73				32		30		26	25		22	21	19	18																																																																	
				15		14		10	9		6		3																																																																		
AVAILABLE	NOT APPLICABLE	34566-3173	G	0	A	BLACK	<table border="1"> <tr><td></td><td>70</td><td>69</td><td></td><td></td><td></td><td>63</td><td></td><td></td><td></td><td></td><td>58</td><td>56</td><td>54</td><td></td></tr> <tr><td>52</td><td>51</td><td>49</td><td></td><td></td><td></td><td>44</td><td>43</td><td>42</td><td>41</td><td></td><td></td><td>36</td><td>34</td><td></td></tr> <tr><td colspan="2">73</td><td></td><td></td><td>32</td><td></td><td>28</td><td></td><td>26</td><td></td><td></td><td></td><td></td><td>19</td><td>18</td></tr> <tr><td colspan="2"></td><td></td><td></td><td>16</td><td></td><td>12</td><td></td><td>10</td><td></td><td></td><td></td><td></td><td>3</td><td>2</td></tr> </table>		70	69				63					58	56	54		52	51	49				44	43	42	41			36	34		73				32		28		26					19	18					16		12		10					3	2												
	70	69				63					58	56	54																																																																		
52	51	49				44	43	42	41			36	34																																																																		
73				32		28		26					19	18																																																																	
				16		12		10					3	2																																																																	
AVAILABLE	NOT APPLICABLE	34566-3183	G	0	C	BLUE	<table border="1"> <tr><td>72</td><td>70</td><td></td><td></td><td></td><td></td><td>66</td><td></td><td>63</td><td>62</td><td></td><td>59</td><td>57</td><td>56</td><td>55</td><td>53</td></tr> <tr><td>52</td><td>51</td><td></td><td></td><td></td><td></td><td>46</td><td>44</td><td>42</td><td>40</td><td>39</td><td></td><td></td><td></td><td></td><td>34</td><td>33</td></tr> <tr><td colspan="2">73</td><td></td><td></td><td></td><td></td><td>30</td><td></td><td></td><td>26</td><td>25</td><td></td><td>22</td><td>21</td><td></td><td></td><td></td></tr> <tr><td colspan="2"></td><td></td><td></td><td>15</td><td></td><td>14</td><td></td><td></td><td>10</td><td>9</td><td></td><td>6</td><td></td><td></td><td></td><td></td></tr> </table>	72	70					66		63	62		59	57	56	55	53	52	51					46	44	42	40	39					34	33	73						30			26	25		22	21								15		14			10	9		6									
72	70					66		63	62		59	57	56	55	53																																																																
52	51					46	44	42	40	39					34	33																																																															
73						30			26	25		22	21																																																																		
				15		14			10	9		6																																																																			
AVAILABLE	NOT APPLICABLE	34566-3193	G	0	A	BLACK	<table border="1"> <tr><td></td><td></td><td>69</td><td></td><td></td><td></td><td></td><td></td><td>63</td><td></td><td></td><td></td><td>58</td><td>56</td><td>55</td><td>54</td><td>53</td></tr> <tr><td>52</td><td>51</td><td>49</td><td></td><td></td><td></td><td></td><td></td><td>44</td><td>43</td><td>42</td><td>41</td><td></td><td></td><td>36</td><td>35</td><td>34</td><td>33</td></tr> <tr><td colspan="2">73</td><td></td><td></td><td>32</td><td></td><td></td><td></td><td>28</td><td>26</td><td></td><td></td><td></td><td></td><td></td><td>19</td><td>18</td><td>17</td></tr> <tr><td colspan="2"></td><td></td><td></td><td>16</td><td></td><td></td><td></td><td>12</td><td>10</td><td></td><td></td><td></td><td></td><td></td><td>3</td><td>2</td><td>1</td></tr> </table>			69						63				58	56	55	54	53	52	51	49						44	43	42	41			36	35	34	33	73				32				28	26						19	18	17					16				12	10						3	2	1	
		69						63				58	56	55	54	53																																																															
52	51	49						44	43	42	41			36	35	34	33																																																														
73				32				28	26						19	18	17																																																														
				16				12	10						3	2	1																																																														
AVAILABLE	NOT APPLICABLE	34566-3213	G	0	C	BLUE	<table border="1"> <tr><td>72</td><td>70</td><td></td><td></td><td></td><td></td><td>67</td><td>66</td><td></td><td>63</td><td>62</td><td></td><td>59</td><td></td><td>56</td><td></td><td>53</td></tr> <tr><td>52</td><td>51</td><td></td><td></td><td></td><td></td><td>46</td><td>44</td><td></td><td>42</td><td>40</td><td></td><td></td><td></td><td></td><td></td><td>34</td><td>33</td></tr> <tr><td colspan="2">73</td><td></td><td></td><td>32</td><td></td><td>30</td><td></td><td></td><td>26</td><td>25</td><td></td><td>22</td><td>21</td><td></td><td></td><td></td><td></td></tr> <tr><td colspan="2"></td><td></td><td></td><td>15</td><td></td><td>14</td><td></td><td></td><td>10</td><td>9</td><td></td><td>6</td><td>5</td><td>4</td><td></td><td></td><td></td></tr> </table>	72	70					67	66		63	62		59		56		53	52	51					46	44		42	40						34	33	73				32		30			26	25		22	21									15		14			10	9		6	5	4				
72	70					67	66		63	62		59		56		53																																																															
52	51					46	44		42	40						34	33																																																														
73				32		30			26	25		22	21																																																																		
				15		14			10	9		6	5	4																																																																	
AVAILABLE	NOT APPLICABLE	34566-3223	G	0	C	BLUE	<table border="1"> <tr><td>72</td><td>70</td><td></td><td></td><td></td><td></td><td>67</td><td>66</td><td></td><td>63</td><td>62</td><td></td><td>59</td><td>57</td><td></td><td></td><td>53</td></tr> <tr><td>52</td><td>51</td><td></td><td></td><td></td><td></td><td>46</td><td>44</td><td></td><td>42</td><td>40</td><td>39</td><td></td><td></td><td></td><td></td><td>34</td><td>33</td></tr> <tr><td colspan="2">73</td><td></td><td></td><td>32</td><td></td><td>30</td><td></td><td>27</td><td>26</td><td>25</td><td></td><td>22</td><td>21</td><td></td><td></td><td></td><td></td></tr> <tr><td colspan="2"></td><td></td><td></td><td>15</td><td></td><td>14</td><td></td><td></td><td>10</td><td>9</td><td></td><td>6</td><td>5</td><td>4</td><td></td><td></td><td></td></tr> </table>	72	70					67	66		63	62		59	57			53	52	51					46	44		42	40	39					34	33	73				32		30		27	26	25		22	21									15		14			10	9		6	5	4				
72	70					67	66		63	62		59	57			53																																																															
52	51					46	44		42	40	39					34	33																																																														
73				32		30		27	26	25		22	21																																																																		
				15		14			10	9		6	5	4																																																																	
AVAILABLE	NOT APPLICABLE	34566-3233	G	0	A	BLACK	<table border="1"> <tr><td></td><td>70</td><td>69</td><td></td><td></td><td></td><td></td><td></td><td>63</td><td>62</td><td>61</td><td></td><td>58</td><td>57</td><td>56</td><td>55</td><td>54</td><td>53</td></tr> <tr><td>52</td><td>51</td><td>49</td><td></td><td></td><td></td><td></td><td></td><td>44</td><td>43</td><td>42</td><td>41</td><td></td><td></td><td>37</td><td>36</td><td>34</td><td></td></tr> <tr><td colspan="2">73</td><td></td><td></td><td>32</td><td></td><td>29</td><td>28</td><td>27</td><td>26</td><td></td><td></td><td></td><td></td><td></td><td></td><td>19</td><td>18</td></tr> <tr><td colspan="2"></td><td></td><td></td><td>16</td><td>15</td><td>13</td><td>12</td><td>11</td><td>10</td><td></td><td></td><td></td><td></td><td></td><td></td><td>3</td><td></td></tr> </table>		70	69						63	62	61		58	57	56	55	54	53	52	51	49						44	43	42	41			37	36	34		73				32		29	28	27	26							19	18					16	15	13	12	11	10							3	
	70	69						63	62	61		58	57	56	55	54	53																																																														
52	51	49						44	43	42	41			37	36	34																																																															
73				32		29	28	27	26							19	18																																																														
				16	15	13	12	11	10							3																																																															
AVAILABLE	NOT APPLICABLE	34566-3243	G	0	C	BLUE	<table border="1"> <tr><td>72</td><td>70</td><td></td><td></td><td></td><td></td><td>66</td><td></td><td>63</td><td>62</td><td></td><td>59</td><td>57</td><td></td><td></td><td></td><td>53</td></tr> <tr><td>52</td><td>51</td><td></td><td></td><td></td><td></td><td>46</td><td>44</td><td></td><td>42</td><td>40</td><td>39</td><td></td><td></td><td></td><td></td><td>34</td><td>33</td></tr> <tr><td colspan="2">73</td><td></td><td></td><td>32</td><td></td><td>30</td><td></td><td></td><td>26</td><td>25</td><td></td><td>22</td><td>21</td><td></td><td></td><td></td><td></td></tr> <tr><td colspan="2"></td><td></td><td></td><td>15</td><td></td><td>14</td><td></td><td></td><td>10</td><td>9</td><td></td><td>6</td><td>5</td><td>4</td><td></td><td></td><td></td></tr> </table>	72	70					66		63	62		59	57				53	52	51					46	44		42	40	39					34	33	73				32		30			26	25		22	21									15		14			10	9		6	5	4				
72	70					66		63	62		59	57				53																																																															
52	51					46	44		42	40	39					34	33																																																														
73				32		30			26	25		22	21																																																																		
				15		14			10	9		6	5	4																																																																	

ENTER DESCRIPTION IEC NO: UAU2014-0574 DRAWNS: SKRAJENDRANA 2013/10/08 CHKD: APPR: WOSHY 2013/10/09 REV: 00	QUALITY SYMBOLS	GENERAL TOLERANCES (UNLESS SPECIFIED)	DIMENSION STYLE	SCALE	DESIGN UNITS	THIRD ANGLE PROJECTION	
	$\nabla=0$ $\nabla=0$ $\nabla=0$	4 PLACES ±---+--- 3 PLACES ±---+--- 2 PLACES ±---+--- 1 PLACE ±---+--- 0 PLACE ±---+---	mm INCH ±---+--- ±---+--- ±---+--- ±---+---	MM ONLY		METRIC	
				DRAWN BY: SKRAJENDRANA 2011/02/14	DATE	TITLE	MX123
				CHECKED BY: MYANSLAMBROU 2011/02/14	DATE		66/73/80CKT HRNS CONN ASSY
			APPROVED BY:	DATE		molex	
			MATERIAL NO.	DOCUMENT NO.		SD-34566-001	
			ANGULAR ±---+--- DRAFT WHERE APPLICABLE MUST REMAIN WITHIN DIMENSIONS	SIZE		SEE BOM TABLE	
			THIS DRAWING CONTAINS INFORMATION THAT IS PROPRIETARY TO MOLEX INCORPORATED AND SHOULD NOT BE USED WITHOUT WRITTEN PERMISSION				SHEET NO. 38 OF 68

STATUS	GM PART #	MATERIAL #	PART/MATERIAL REVISION	WIRE DRESS OPTION	KEY OPTION	COLOR (TPA)	NUMBERS INDICATE CAVITIES OPEN FOR CIRCUITS																																																																								
AVAILABLE	NOT APPLICABLE	34566-3253	G	0	A	BLACK	<table border="1"> <tr><td></td><td>70</td><td>69</td><td></td><td></td><td></td><td>63</td><td></td><td></td><td></td><td>58</td><td>56</td><td>55</td><td>54</td><td>53</td></tr> <tr><td>52</td><td>51</td><td>49</td><td></td><td></td><td></td><td>44</td><td>43</td><td>42</td><td>41</td><td></td><td></td><td>36</td><td>34</td><td></td></tr> <tr><td></td><td></td><td>73</td><td>32</td><td></td><td></td><td>28</td><td>26</td><td></td><td></td><td></td><td></td><td>19</td><td>18</td><td></td></tr> <tr><td></td><td></td><td></td><td>16</td><td>15</td><td></td><td>12</td><td>10</td><td></td><td></td><td></td><td></td><td>3</td><td></td><td></td></tr> </table>		70	69				63				58	56	55	54	53	52	51	49				44	43	42	41			36	34				73	32			28	26					19	18					16	15		12	10					3														
	70	69				63				58	56	55	54	53																																																																	
52	51	49				44	43	42	41			36	34																																																																		
		73	32			28	26					19	18																																																																		
			16	15		12	10					3																																																																			
AVAILABLE	NOT APPLICABLE	34566-3263	G	0	C	BLUE	<table border="1"> <tr><td>72</td><td>70</td><td></td><td></td><td>66</td><td></td><td>63</td><td>62</td><td></td><td></td><td>59</td><td>57</td><td>56</td><td>55</td><td>53</td></tr> <tr><td>52</td><td>51</td><td></td><td></td><td>46</td><td>44</td><td>42</td><td>40</td><td>39</td><td></td><td></td><td></td><td></td><td>34</td><td>33</td></tr> <tr><td></td><td></td><td>73</td><td>32</td><td>30</td><td></td><td>26</td><td>25</td><td></td><td></td><td>22</td><td>21</td><td>19</td><td>18</td><td></td></tr> <tr><td></td><td></td><td></td><td>15</td><td>14</td><td></td><td>10</td><td>9</td><td></td><td></td><td>6</td><td>5</td><td>4</td><td>3</td><td></td></tr> </table>	72	70			66		63	62			59	57	56	55	53	52	51			46	44	42	40	39					34	33			73	32	30		26	25			22	21	19	18					15	14		10	9			6	5	4	3													
72	70			66		63	62			59	57	56	55	53																																																																	
52	51			46	44	42	40	39					34	33																																																																	
		73	32	30		26	25			22	21	19	18																																																																		
			15	14		10	9			6	5	4	3																																																																		
AVAILABLE	NOT APPLICABLE	34566-3273	G	0	A	BLACK	<table border="1"> <tr><td></td><td>70</td><td>69</td><td></td><td></td><td></td><td>63</td><td></td><td></td><td></td><td>58</td><td>56</td><td>55</td><td>54</td><td>53</td></tr> <tr><td>52</td><td>51</td><td>49</td><td></td><td></td><td></td><td>44</td><td>43</td><td>42</td><td>41</td><td></td><td></td><td>36</td><td>34</td><td></td></tr> <tr><td></td><td></td><td>73</td><td>32</td><td></td><td></td><td>28</td><td>26</td><td></td><td></td><td></td><td></td><td>19</td><td>18</td><td>17</td></tr> <tr><td></td><td></td><td></td><td>16</td><td>15</td><td></td><td>12</td><td>10</td><td></td><td></td><td></td><td></td><td>3</td><td>2</td><td>1</td></tr> </table>		70	69				63				58	56	55	54	53	52	51	49				44	43	42	41			36	34				73	32			28	26					19	18	17				16	15		12	10					3	2	1												
	70	69				63				58	56	55	54	53																																																																	
52	51	49				44	43	42	41			36	34																																																																		
		73	32			28	26					19	18	17																																																																	
			16	15		12	10					3	2	1																																																																	
AVAILABLE	NOT APPLICABLE	34566-3283	G	0	C	BLUE	<table border="1"> <tr><td>72</td><td>70</td><td></td><td>67</td><td>66</td><td></td><td>63</td><td>62</td><td></td><td></td><td>59</td><td>57</td><td></td><td></td><td>53</td></tr> <tr><td>52</td><td>51</td><td></td><td></td><td>46</td><td>44</td><td>42</td><td>40</td><td>39</td><td></td><td></td><td></td><td></td><td>34</td><td>33</td></tr> <tr><td></td><td></td><td>73</td><td></td><td>30</td><td></td><td>26</td><td>25</td><td></td><td></td><td>22</td><td>21</td><td></td><td></td><td></td></tr> <tr><td></td><td></td><td></td><td>15</td><td>14</td><td></td><td>10</td><td>9</td><td></td><td></td><td>6</td><td>5</td><td>4</td><td></td><td></td></tr> </table>	72	70		67	66		63	62			59	57			53	52	51			46	44	42	40	39					34	33			73		30		26	25			22	21							15	14		10	9			6	5	4														
72	70		67	66		63	62			59	57			53																																																																	
52	51			46	44	42	40	39					34	33																																																																	
		73		30		26	25			22	21																																																																				
			15	14		10	9			6	5	4																																																																			
AVAILABLE	NOT APPLICABLE	34566-3293	G	0	B	ST GRAY	<table border="1"> <tr><td>72</td><td>71</td><td>70</td><td>68</td><td>67</td><td>66</td><td></td><td></td><td>62</td><td>61</td><td>60</td><td>59</td><td>58</td><td>57</td><td>56</td><td>55</td><td>54</td><td>53</td></tr> <tr><td>52</td><td>51</td><td>50</td><td>48</td><td>47</td><td></td><td></td><td></td><td>42</td><td>41</td><td>40</td><td>39</td><td>38</td><td>37</td><td>36</td><td>35</td><td>34</td><td>33</td></tr> <tr><td></td><td></td><td>73</td><td>32</td><td>31</td><td>30</td><td>29</td><td>28</td><td>27</td><td>26</td><td>25</td><td>24</td><td>23</td><td></td><td></td><td></td><td></td><td></td></tr> <tr><td></td><td></td><td></td><td>16</td><td>15</td><td>14</td><td>13</td><td></td><td></td><td>10</td><td>9</td><td>8</td><td></td><td></td><td></td><td></td><td></td><td></td></tr> </table>	72	71	70	68	67	66			62	61	60	59	58	57	56	55	54	53	52	51	50	48	47				42	41	40	39	38	37	36	35	34	33			73	32	31	30	29	28	27	26	25	24	23									16	15	14	13			10	9	8						
72	71	70	68	67	66			62	61	60	59	58	57	56	55	54	53																																																														
52	51	50	48	47				42	41	40	39	38	37	36	35	34	33																																																														
		73	32	31	30	29	28	27	26	25	24	23																																																																			
			16	15	14	13			10	9	8																																																																				
AVAILABLE	NOT APPLICABLE	34566-3313	G	0	C	BLUE	<table border="1"> <tr><td>72</td><td>70</td><td></td><td></td><td></td><td></td><td>63</td><td>62</td><td></td><td></td><td>59</td><td>57</td><td></td><td></td><td>53</td></tr> <tr><td>52</td><td>51</td><td></td><td></td><td>46</td><td>44</td><td>42</td><td>40</td><td>39</td><td></td><td></td><td></td><td></td><td>34</td><td>33</td></tr> <tr><td></td><td></td><td>73</td><td>32</td><td>30</td><td></td><td>26</td><td>25</td><td></td><td></td><td>22</td><td>21</td><td></td><td></td><td></td></tr> <tr><td></td><td></td><td></td><td>15</td><td>14</td><td></td><td></td><td></td><td></td><td></td><td>6</td><td>5</td><td>4</td><td></td><td></td></tr> </table>	72	70					63	62			59	57			53	52	51			46	44	42	40	39					34	33			73	32	30		26	25			22	21							15	14						6	5	4														
72	70					63	62			59	57			53																																																																	
52	51			46	44	42	40	39					34	33																																																																	
		73	32	30		26	25			22	21																																																																				
			15	14						6	5	4																																																																			
AVAILABLE	NOT APPLICABLE	34566-3323	G	0	B	ST GRAY	<table border="1"> <tr><td></td><td></td><td></td><td>68</td><td>67</td><td>66</td><td>65</td><td>64</td><td>63</td><td></td><td></td><td></td><td>58</td><td></td><td>55</td><td></td><td></td><td></td></tr> <tr><td></td><td></td><td>49</td><td>48</td><td>46</td><td>45</td><td>44</td><td>43</td><td></td><td></td><td></td><td></td><td>38</td><td></td><td></td><td></td><td></td><td></td></tr> <tr><td></td><td></td><td>73</td><td>32</td><td>30</td><td>29</td><td>28</td><td>27</td><td></td><td></td><td></td><td>22</td><td></td><td></td><td></td><td></td><td></td><td>17</td></tr> <tr><td></td><td></td><td></td><td>16</td><td></td><td></td><td></td><td></td><td>10</td><td></td><td></td><td></td><td></td><td></td><td></td><td></td><td></td><td></td></tr> </table>				68	67	66	65	64	63				58		55						49	48	46	45	44	43					38								73	32	30	29	28	27				22						17				16					10									
			68	67	66	65	64	63				58		55																																																																	
		49	48	46	45	44	43					38																																																																			
		73	32	30	29	28	27				22						17																																																														
			16					10																																																																							
AVAILABLE	NOT APPLICABLE	34566-3333	G	0	A	BLACK	<table border="1"> <tr><td>72</td><td>71</td><td>70</td><td>69</td><td>68</td><td></td><td>65</td><td>64</td><td>63</td><td></td><td>61</td><td>59</td><td>58</td><td>57</td><td>56</td><td></td><td>54</td><td></td></tr> <tr><td>52</td><td>51</td><td>50</td><td>49</td><td>47</td><td></td><td></td><td></td><td>42</td><td>41</td><td></td><td></td><td>38</td><td>37</td><td>36</td><td></td><td>34</td><td>33</td></tr> <tr><td></td><td></td><td>73</td><td>32</td><td>31</td><td>30</td><td>29</td><td>28</td><td>27</td><td>26</td><td></td><td>24</td><td>23</td><td></td><td></td><td>20</td><td>19</td><td>18</td></tr> <tr><td></td><td></td><td></td><td>16</td><td></td><td></td><td>13</td><td>12</td><td>11</td><td>10</td><td>9</td><td></td><td></td><td></td><td></td><td>3</td><td>2</td><td>1</td></tr> </table>	72	71	70	69	68		65	64	63		61	59	58	57	56		54		52	51	50	49	47				42	41			38	37	36		34	33			73	32	31	30	29	28	27	26		24	23			20	19	18				16			13	12	11	10	9					3	2	1
72	71	70	69	68		65	64	63		61	59	58	57	56		54																																																															
52	51	50	49	47				42	41			38	37	36		34	33																																																														
		73	32	31	30	29	28	27	26		24	23			20	19	18																																																														
			16			13	12	11	10	9					3	2	1																																																														

ENTER DESCRIPTION IEC NO: UAU2014-0574 DRAWN: SKRAJENDRANA 2013/10/08 CHKD: APPR: IKOSHY 2013/10/09 REV:	QUALITY SYMBOLS	GENERAL TOLERANCES (UNLESS SPECIFIED)	DIMENSION STYLE	SCALE	DESIGN UNITS	THIRD ANGLE PROJECTION	
	$\nabla=0$ $\nabla=0$ $\nabla=0$	4 PLACES ±--- 3 PLACES ±--- 2 PLACES ±--- 1 PLACE ±--- 0 PLACE ±---	mm INCH ±--- ±--- ±--- ±--- ±--- ±--- ±--- ±---	MM ONLY		METRIC	
				DRAWN BY: SKRAJENDRANA 2011/02/14	DATE	TITLE	MX123 66/73/80CKT HRNS CONN ASSY
				CHECKED BY: MVANSLAMBROU 2011/02/14	DATE	APPROVED BY: DATE	molex MATERIAL NO. SD-34566-001 DOCUMENT NO. SD-34566-001 SHEET NO. 39 OF 68
			DRAFT WHERE APPLICABLE MUST REMAIN WITHIN DIMENSIONS SEE BOM TABLE THIS DRAWING CONTAINS INFORMATION THAT IS PROPRIETARY TO MOLEX INCORPORATED AND SHOULD NOT BE USED WITHOUT WRITTEN PERMISSION				

STATUS	GM PART #	MATERIAL #	PART / MATERIAL REVISION	WIRE DRESS OPTION	KEY OPTION	COLOR (TPA)	NUMBERS INDICATE CAVITIES OPEN FOR CIRCUITS																																																																			
AVAILABLE	NOT APPLICABLE	34566-3343	G	0	A	BLACK	<table border="1"> <tr><td>72</td><td></td><td>69</td><td>67</td><td>66</td><td>65</td><td>63</td><td></td><td>60</td><td></td><td>57</td><td>56</td><td></td><td>53</td></tr> <tr><td></td><td></td><td>49</td><td>47</td><td></td><td>44</td><td>43</td><td>42</td><td>40</td><td></td><td>37</td><td>36</td><td>35</td><td>33</td></tr> <tr><td>73</td><td></td><td></td><td>31</td><td>30</td><td>29</td><td>28</td><td>26</td><td>24</td><td></td><td>21</td><td>20</td><td></td><td>17</td></tr> <tr><td></td><td></td><td>16</td><td>15</td><td>14</td><td>13</td><td></td><td>11</td><td>10</td><td></td><td>5</td><td>4</td><td>3</td><td>2</td><td>1</td></tr> </table>	72		69	67	66	65	63		60		57	56		53			49	47		44	43	42	40		37	36	35	33	73			31	30	29	28	26	24		21	20		17			16	15	14	13		11	10		5	4	3	2	1										
72		69	67	66	65	63		60		57	56		53																																																													
		49	47		44	43	42	40		37	36	35	33																																																													
73			31	30	29	28	26	24		21	20		17																																																													
		16	15	14	13		11	10		5	4	3	2	1																																																												
AVAILABLE	NOT APPLICABLE	34566-3353	G	0	B	ST GRY	<table border="1"> <tr><td></td><td></td><td>68</td><td>67</td><td></td><td>64</td><td></td><td></td><td></td><td>59</td><td>58</td><td></td><td></td><td>54</td></tr> <tr><td></td><td></td><td></td><td>46</td><td>45</td><td></td><td></td><td></td><td></td><td>39</td><td>38</td><td></td><td></td><td></td></tr> <tr><td>73</td><td></td><td>32</td><td>30</td><td>29</td><td>28</td><td>27</td><td></td><td></td><td>23</td><td>22</td><td></td><td></td><td>17</td></tr> <tr><td></td><td></td><td></td><td></td><td></td><td>12</td><td>10</td><td></td><td>8</td><td></td><td></td><td></td><td></td><td></td><td>1</td></tr> </table>			68	67		64				59	58			54				46	45					39	38				73		32	30	29	28	27			23	22			17						12	10		8						1										
		68	67		64				59	58			54																																																													
			46	45					39	38																																																																
73		32	30	29	28	27			23	22			17																																																													
					12	10		8						1																																																												
AVAILABLE	NOT APPLICABLE	34566-3363	G	0	A	BLACK	<table border="1"> <tr><td>71</td><td>69</td><td>68</td><td></td><td>65</td><td>64</td><td>63</td><td></td><td>61</td><td></td><td>59</td><td>57</td><td>56</td><td>54</td></tr> <tr><td>52</td><td>50</td><td>49</td><td>47</td><td></td><td></td><td></td><td></td><td>42</td><td>41</td><td>40</td><td>39</td><td>38</td><td>37</td><td>36</td><td>34</td><td>33</td></tr> <tr><td>73</td><td></td><td></td><td>32</td><td>31</td><td>30</td><td>29</td><td>28</td><td>27</td><td>26</td><td>24</td><td>23</td><td>22</td><td></td><td>20</td><td>19</td><td>18</td></tr> <tr><td></td><td></td><td></td><td>16</td><td></td><td></td><td>13</td><td>12</td><td>11</td><td>10</td><td>9</td><td></td><td></td><td></td><td></td><td></td><td>1</td></tr> </table>	71	69	68		65	64	63		61		59	57	56	54	52	50	49	47					42	41	40	39	38	37	36	34	33	73			32	31	30	29	28	27	26	24	23	22		20	19	18				16			13	12	11	10	9						1		
71	69	68		65	64	63		61		59	57	56	54																																																													
52	50	49	47					42	41	40	39	38	37	36	34	33																																																										
73			32	31	30	29	28	27	26	24	23	22		20	19	18																																																										
			16			13	12	11	10	9						1																																																										
AVAILABLE	NOT APPLICABLE	34566-3373	G	9	C	BLUE	<table border="1"> <tr><td>72</td><td>70</td><td>68</td><td>67</td><td>66</td><td></td><td>63</td><td>62</td><td></td><td>59</td><td>57</td><td>56</td><td>55</td><td>53</td></tr> <tr><td>52</td><td>51</td><td></td><td>48</td><td>47</td><td>46</td><td>44</td><td>42</td><td></td><td>40</td><td>39</td><td>38</td><td></td><td>34</td><td>33</td></tr> <tr><td>73</td><td></td><td></td><td>32</td><td>30</td><td></td><td></td><td>26</td><td>25</td><td></td><td></td><td>22</td><td>21</td><td></td><td>19</td><td>18</td></tr> <tr><td></td><td></td><td></td><td>15</td><td>14</td><td></td><td></td><td>10</td><td>9</td><td></td><td></td><td>6</td><td>5</td><td>4</td><td>3</td><td></td></tr> </table>	72	70	68	67	66		63	62		59	57	56	55	53	52	51		48	47	46	44	42		40	39	38		34	33	73			32	30			26	25			22	21		19	18				15	14			10	9			6	5	4	3							
72	70	68	67	66		63	62		59	57	56	55	53																																																													
52	51		48	47	46	44	42		40	39	38		34	33																																																												
73			32	30			26	25			22	21		19	18																																																											
			15	14			10	9			6	5	4	3																																																												
AVAILABLE	NOT APPLICABLE	34566-3383	G	0	A	BLACK	<table border="1"> <tr><td></td><td>70</td><td>69</td><td>68</td><td></td><td>65</td><td>64</td><td>63</td><td></td><td>61</td><td></td><td>59</td><td>58</td><td>57</td><td>56</td><td>54</td></tr> <tr><td>52</td><td>50</td><td>49</td><td>48</td><td>47</td><td></td><td></td><td></td><td></td><td>42</td><td>41</td><td></td><td>38</td><td>37</td><td>36</td><td>34</td><td>33</td></tr> <tr><td>73</td><td></td><td></td><td>32</td><td>31</td><td>30</td><td>29</td><td>28</td><td>27</td><td>26</td><td></td><td>24</td><td>23</td><td></td><td>20</td><td>19</td><td>18</td></tr> <tr><td></td><td></td><td></td><td>16</td><td></td><td></td><td>13</td><td>12</td><td>11</td><td>10</td><td>9</td><td></td><td></td><td></td><td></td><td></td><td>1</td></tr> </table>		70	69	68		65	64	63		61		59	58	57	56	54	52	50	49	48	47					42	41		38	37	36	34	33	73			32	31	30	29	28	27	26		24	23		20	19	18				16			13	12	11	10	9						1
	70	69	68		65	64	63		61		59	58	57	56	54																																																											
52	50	49	48	47					42	41		38	37	36	34	33																																																										
73			32	31	30	29	28	27	26		24	23		20	19	18																																																										
			16			13	12	11	10	9						1																																																										
AVAILABLE	NOT APPLICABLE	34566-3393	G	0	C	BLUE	<table border="1"> <tr><td>72</td><td>70</td><td></td><td>68</td><td>67</td><td>66</td><td></td><td>63</td><td>62</td><td></td><td>59</td><td>57</td><td></td><td>53</td></tr> <tr><td>52</td><td>51</td><td></td><td>48</td><td>47</td><td>46</td><td>44</td><td>42</td><td></td><td>40</td><td>39</td><td></td><td></td><td>34</td><td>33</td></tr> <tr><td>73</td><td></td><td></td><td>32</td><td></td><td>30</td><td></td><td></td><td>26</td><td>25</td><td></td><td>22</td><td>21</td><td></td><td></td><td></td></tr> <tr><td></td><td></td><td></td><td>15</td><td>14</td><td></td><td></td><td></td><td>10</td><td>9</td><td></td><td></td><td>6</td><td>5</td><td>4</td><td></td><td></td></tr> </table>	72	70		68	67	66		63	62		59	57		53	52	51		48	47	46	44	42		40	39			34	33	73			32		30			26	25		22	21							15	14				10	9			6	5	4							
72	70		68	67	66		63	62		59	57		53																																																													
52	51		48	47	46	44	42		40	39			34	33																																																												
73			32		30			26	25		22	21																																																														
			15	14				10	9			6	5	4																																																												
AVAILABLE	NOT APPLICABLE	34566-3413	G	0	A	BLACK	<table border="1"> <tr><td>72</td><td>70</td><td></td><td>67</td><td>66</td><td>65</td><td></td><td></td><td>61</td><td></td><td>58</td><td>57</td><td>55</td><td>54</td></tr> <tr><td></td><td>50</td><td>49</td><td>47</td><td>47</td><td>45</td><td>44</td><td>43</td><td>42</td><td>41</td><td>39</td><td>37</td><td>35</td><td></td></tr> <tr><td>73</td><td></td><td></td><td>32</td><td>30</td><td></td><td></td><td>27</td><td>26</td><td>25</td><td>24</td><td></td><td>21</td><td>20</td><td>19</td><td>18</td><td>17</td></tr> <tr><td></td><td></td><td></td><td>16</td><td>15</td><td>13</td><td></td><td>11</td><td>10</td><td>9</td><td>8</td><td></td><td>6</td><td>5</td><td>3</td><td>2</td><td>1</td></tr> </table>	72	70		67	66	65			61		58	57	55	54		50	49	47	47	45	44	43	42	41	39	37	35		73			32	30			27	26	25	24		21	20	19	18	17				16	15	13		11	10	9	8		6	5	3	2	1					
72	70		67	66	65			61		58	57	55	54																																																													
	50	49	47	47	45	44	43	42	41	39	37	35																																																														
73			32	30			27	26	25	24		21	20	19	18	17																																																										
			16	15	13		11	10	9	8		6	5	3	2	1																																																										
AVAILABLE	NOT APPLICABLE	34566-3423	G	9	C	BLUE	<table border="1"> <tr><td></td><td></td><td>69</td><td></td><td></td><td></td><td>63</td><td></td><td></td><td></td><td>58</td><td>56</td><td>55</td><td>54</td><td>53</td></tr> <tr><td>52</td><td>51</td><td>49</td><td></td><td></td><td></td><td>44</td><td>43</td><td>42</td><td>41</td><td></td><td></td><td>36</td><td>35</td><td>34</td><td>33</td></tr> <tr><td>73</td><td></td><td></td><td></td><td></td><td></td><td>28</td><td>26</td><td></td><td></td><td></td><td></td><td></td><td></td><td>19</td><td>18</td><td>17</td></tr> <tr><td></td><td></td><td></td><td></td><td></td><td></td><td>12</td><td>10</td><td></td><td></td><td></td><td></td><td></td><td></td><td>3</td><td>2</td><td>1</td></tr> </table>			69				63				58	56	55	54	53	52	51	49				44	43	42	41			36	35	34	33	73						28	26							19	18	17							12	10							3	2	1		
		69				63				58	56	55	54	53																																																												
52	51	49				44	43	42	41			36	35	34	33																																																											
73						28	26							19	18	17																																																										
						12	10							3	2	1																																																										

ENTER DESCRIPTION IEC NO: UAU2014-0574 DRAWNSKRAJENDRANA 2013/10/08 CHKD: APPR:KOSHY 2013/10/09	QUALITY SYMBOLS	GENERAL TOLERANCES (UNLESS SPECIFIED)	DIMENSION STYLE	SCALE	DESIGN UNITS	THIRD ANGLE PROJECTION
	▽=0	4 PLACES ± mm ± INCH	MM ONLY		METRIC	
	▽=0	3 PLACES ± mm ± INCH				
	▽=0	2 PLACES ± mm ± INCH				
	1 PLACE ± mm ± INCH					
	0 PLACE ± mm ± INCH					
	ANGULAR ± °					
	DRAFT WHERE APPLICABLE MUST REMAIN WITHIN DIMENSIONS					
			DRAWN BY	DATE	TITLE	
			SKRAJENDRANA	2011/02/14		
			CHECKED BY	DATE		
			MVANS LAMBROU	2011/02/14		
			APPROVED BY	DATE		
			MATERIAL NO.	DOCUMENT NO.		
			SEE BOM TABLE	SD-34566-001		
						SHEET NO. 40 OF 68

MX123
66/73/80CKT
HRNS CONN ASSY

molex

SD-34566-001

STATUS	GM PART #	MATERIAL #	PART/MATERIAL REVISION	WIRE DRESS OPTION	KEY OPTION	COLOR (TPA)	NUMBERS INDICATE CAVITIES OPEN FOR CIRCUITS																																																																																
AVAILABLE	NOT APPLICABLE	34566-3433	G	9	C	BLUE	<table border="1"> <tr><td>72</td><td>70</td><td></td><td></td><td>66</td><td></td><td>63</td><td>62</td><td></td><td></td><td>59</td><td></td><td>57</td><td>56</td><td>55</td><td>53</td></tr> <tr><td>52</td><td>51</td><td></td><td></td><td>46</td><td>44</td><td>42</td><td>40</td><td>39</td><td></td><td>22</td><td>21</td><td></td><td></td><td>34</td><td>33</td></tr> <tr><td></td><td>73</td><td></td><td></td><td>30</td><td></td><td>26</td><td>25</td><td></td><td></td><td>6</td><td></td><td></td><td></td><td></td><td></td></tr> <tr><td></td><td></td><td></td><td></td><td>15</td><td>14</td><td></td><td>10</td><td>9</td><td></td><td></td><td></td><td></td><td></td><td></td><td></td></tr> </table>	72	70			66		63	62			59		57	56	55	53	52	51			46	44	42	40	39		22	21			34	33		73			30		26	25			6										15	14		10	9																							
72	70			66		63	62			59		57	56	55	53																																																																								
52	51			46	44	42	40	39		22	21			34	33																																																																								
	73			30		26	25			6																																																																													
				15	14		10	9																																																																															
AVAILABLE	NOT APPLICABLE	34566-3443	G	0	A	BLACK	<table border="1"> <tr><td></td><td>71</td><td>69</td><td></td><td></td><td>65</td><td>64</td><td>63</td><td></td><td>60</td><td></td><td></td><td>57</td><td>56</td><td>55</td><td>54</td><td>53</td></tr> <tr><td>52</td><td>51</td><td>49</td><td></td><td></td><td>45</td><td>44</td><td>43</td><td>42</td><td>41</td><td></td><td>23</td><td></td><td></td><td>19</td><td>18</td><td></td></tr> <tr><td></td><td>73</td><td></td><td>32</td><td>30</td><td>28</td><td>26</td><td></td><td></td><td></td><td></td><td></td><td></td><td></td><td>3</td><td></td><td></td></tr> <tr><td></td><td></td><td></td><td>16</td><td></td><td>12</td><td>10</td><td></td><td></td><td></td><td></td><td></td><td></td><td></td><td></td><td></td><td></td></tr> </table>		71	69			65	64	63		60			57	56	55	54	53	52	51	49			45	44	43	42	41		23			19	18			73		32	30	28	26								3						16		12	10																						
	71	69			65	64	63		60			57	56	55	54	53																																																																							
52	51	49			45	44	43	42	41		23			19	18																																																																								
	73		32	30	28	26								3																																																																									
			16		12	10																																																																																	
AVAILABLE	NOT APPLICABLE	34566-3453	G	0	A	BLACK	<table border="1"> <tr><td></td><td></td><td></td><td></td><td></td><td></td><td></td><td></td><td></td><td>61</td><td></td><td></td><td></td><td></td><td></td><td></td><td></td></tr> <tr><td></td><td></td><td></td><td></td><td></td><td></td><td></td><td></td><td></td><td></td><td></td><td></td><td></td><td></td><td>20</td><td></td><td></td></tr> <tr><td></td><td>73</td><td></td><td></td><td></td><td></td><td></td><td></td><td></td><td>9</td><td></td><td></td><td></td><td>5</td><td></td><td></td><td>1</td></tr> </table>										61																						20				73								9				5			1																													
									61																																																																														
														20																																																																									
	73								9				5			1																																																																							
AVAILABLE	NOT APPLICABLE	34566-3463	G	9	H	ST GRY	<table border="1"> <tr><td></td><td></td><td></td><td></td><td></td><td></td><td></td><td></td><td></td><td></td><td></td><td></td><td></td><td></td><td></td><td></td><td>61</td></tr> <tr><td>20</td><td></td><td></td><td></td><td></td><td></td><td></td><td></td><td></td><td>9</td><td></td><td></td><td></td><td>5</td><td></td><td></td><td>1</td></tr> </table>																	61	20									9				5			1																																														
																61																																																																							
20									9				5			1																																																																							
AVAILABLE	NOT APPLICABLE	34566-3473	G	9	B	ST GRY	<table border="1"> <tr><td>72</td><td>71</td><td>70</td><td>69</td><td>68</td><td>67</td><td>66</td><td>65</td><td>64</td><td></td><td>62</td><td>61</td><td>60</td><td>59</td><td>58</td><td>57</td><td>56</td><td>55</td><td>54</td></tr> <tr><td>52</td><td>51</td><td>50</td><td>49</td><td></td><td>46</td><td>44</td><td></td><td></td><td></td><td></td><td>40</td><td>38</td><td>37</td><td>36</td><td></td><td></td><td></td><td></td></tr> <tr><td></td><td>73</td><td></td><td></td><td>32</td><td>31</td><td>30</td><td>29</td><td>28</td><td>27</td><td></td><td>25</td><td>24</td><td></td><td></td><td>21</td><td>20</td><td>18</td><td>17</td></tr> <tr><td></td><td></td><td></td><td></td><td>16</td><td>15</td><td>14</td><td>13</td><td>12</td><td></td><td>10</td><td>9</td><td></td><td>7</td><td>6</td><td>5</td><td>4</td><td>3</td><td>2</td></tr> </table>	72	71	70	69	68	67	66	65	64		62	61	60	59	58	57	56	55	54	52	51	50	49		46	44					40	38	37	36						73			32	31	30	29	28	27		25	24			21	20	18	17					16	15	14	13	12		10	9		7	6	5	4	3	2				
72	71	70	69	68	67	66	65	64		62	61	60	59	58	57	56	55	54																																																																					
52	51	50	49		46	44					40	38	37	36																																																																									
	73			32	31	30	29	28	27		25	24			21	20	18	17																																																																					
				16	15	14	13	12		10	9		7	6	5	4	3	2																																																																					
AVAILABLE	NOT APPLICABLE	34566-3483	G	0	B	ST GRY	<table border="1"> <tr><td>72</td><td>71</td><td>70</td><td>69</td><td>68</td><td>67</td><td>66</td><td>65</td><td></td><td></td><td>61</td><td>60</td><td></td><td></td><td>57</td><td>56</td><td>55</td><td>54</td></tr> <tr><td>52</td><td>51</td><td>50</td><td>49</td><td>48</td><td>46</td><td>44</td><td></td><td></td><td></td><td>40</td><td>38</td><td>37</td><td>36</td><td></td><td></td><td></td><td></td></tr> <tr><td></td><td>73</td><td></td><td></td><td>32</td><td>31</td><td>30</td><td>29</td><td>28</td><td>27</td><td></td><td>24</td><td></td><td></td><td>21</td><td>20</td><td>19</td><td>18</td><td>17</td></tr> <tr><td></td><td></td><td></td><td></td><td>16</td><td>15</td><td>14</td><td>13</td><td>12</td><td>11</td><td>10</td><td>9</td><td></td><td>7</td><td>6</td><td>5</td><td>4</td><td>3</td><td>2</td></tr> </table>	72	71	70	69	68	67	66	65			61	60			57	56	55	54	52	51	50	49	48	46	44				40	38	37	36						73			32	31	30	29	28	27		24			21	20	19	18	17					16	15	14	13	12	11	10	9		7	6	5	4	3	2						
72	71	70	69	68	67	66	65			61	60			57	56	55	54																																																																						
52	51	50	49	48	46	44				40	38	37	36																																																																										
	73			32	31	30	29	28	27		24			21	20	19	18	17																																																																					
				16	15	14	13	12	11	10	9		7	6	5	4	3	2																																																																					
AVAILABLE	NOT APPLICABLE	34566-3493	G	0	A	BLACK	<table border="1"> <tr><td>72</td><td>70</td><td></td><td></td><td>67</td><td>66</td><td>65</td><td></td><td></td><td></td><td>61</td><td></td><td></td><td>58</td><td>57</td><td></td><td>55</td><td>54</td></tr> <tr><td></td><td>49</td><td></td><td></td><td>47</td><td>45</td><td>44</td><td>43</td><td>42</td><td>41</td><td>39</td><td></td><td></td><td>37</td><td>35</td><td></td><td></td><td></td></tr> <tr><td></td><td>73</td><td></td><td></td><td>32</td><td></td><td>30</td><td></td><td>27</td><td>26</td><td>25</td><td>24</td><td></td><td></td><td>21</td><td>20</td><td>19</td><td>18</td><td>17</td></tr> <tr><td></td><td></td><td></td><td></td><td>16</td><td>15</td><td>13</td><td></td><td>11</td><td>10</td><td>9</td><td>8</td><td></td><td>6</td><td>5</td><td></td><td>3</td><td>2</td><td>1</td></tr> </table>	72	70			67	66	65				61			58	57		55	54		49			47	45	44	43	42	41	39			37	35					73			32		30		27	26	25	24			21	20	19	18	17					16	15	13		11	10	9	8		6	5		3	2	1						
72	70			67	66	65				61			58	57		55	54																																																																						
	49			47	45	44	43	42	41	39			37	35																																																																									
	73			32		30		27	26	25	24			21	20	19	18	17																																																																					
				16	15	13		11	10	9	8		6	5		3	2	1																																																																					
AVAILABLE	NOT APPLICABLE	34566-3513	G	0	A	BLACK	<table border="1"> <tr><td></td><td>70</td><td>69</td><td></td><td></td><td></td><td></td><td></td><td>63</td><td>62</td><td>61</td><td>60</td><td></td><td></td><td>58</td><td>57</td><td>56</td><td>55</td><td>54</td><td>53</td></tr> <tr><td>52</td><td>51</td><td>49</td><td></td><td></td><td></td><td></td><td></td><td>44</td><td>43</td><td>42</td><td>41</td><td></td><td></td><td></td><td></td><td>37</td><td>36</td><td>34</td><td></td></tr> <tr><td></td><td>73</td><td></td><td></td><td></td><td></td><td></td><td></td><td>29</td><td>28</td><td>27</td><td>26</td><td></td><td></td><td></td><td></td><td></td><td></td><td>19</td><td>18</td></tr> <tr><td></td><td></td><td></td><td></td><td></td><td></td><td></td><td></td><td>16</td><td>15</td><td>13</td><td>12</td><td>11</td><td>10</td><td></td><td></td><td></td><td></td><td>3</td><td></td></tr> </table>		70	69						63	62	61	60			58	57	56	55	54	53	52	51	49						44	43	42	41					37	36	34			73							29	28	27	26							19	18									16	15	13	12	11	10					3	
	70	69						63	62	61	60			58	57	56	55	54	53																																																																				
52	51	49						44	43	42	41					37	36	34																																																																					
	73							29	28	27	26							19	18																																																																				
								16	15	13	12	11	10					3																																																																					

ENTER DESCRIPTION IEC NO: UAU2014-0574 DRWNSKRAJENDRANA 2013/10/08 CHKD: APPR: IKOSHY 2013/10/09 GO	QUALITY SYMBOLS	GENERAL TOLERANCES (UNLESS SPECIFIED)	DIMENSION STYLE	SCALE	DESIGN UNITS	THIRD ANGLE PROJECTION	
	∇=0 ∇=0 ∇=0	4 PLACES #--- #--- 3 PLACES #--- #--- 2 PLACES #--- #--- 1 PLACE #--- #--- 0 PLACE #--- #---	mm INCH ANGULAR ±---° DRAFT WHERE APPLICABLE MUST REMAIN WITHIN DIMENSIONS	MM ONLY DRAWN BY: SKRAJENDRANA 2011/02/14 CHECKED BY: MVANSLAMBROU 2011/02/14 APPROVED BY:	DATE DATE DATE	METRIC MX123 66/73/80CKT HRNS CONN ASSY molex	SHEET NO. 41 OF 68
	SEE BOM TABLE			MATERIAL NO. DOCUMENT NO.		SD-34566-001	
	THIS DRAWING CONTAINS INFORMATION THAT IS PROPRIETARY TO MOLEX INCORPORATED AND SHOULD NOT BE USED WITHOUT WRITTEN PERMISSION						

STATUS	GM PART #	MATERIAL #	PART/MATERIAL REVISION	WIRE DRESS OPTION	KEY OPTION	COLOR (TPA)	NUMBERS INDICATE CAVITIES OPEN FOR CIRCUITS																																																																																					
SALEABLE	NOT APPLICABLE	34566-3523	G	0	A	BLACK	<table border="1"> <tr><td>72</td><td>70</td><td></td><td></td><td>66</td><td></td><td>63</td><td>62</td><td></td><td></td><td></td><td></td><td></td><td></td><td>56</td><td>55</td><td>54</td></tr> <tr><td>52</td><td></td><td>49</td><td></td><td></td><td></td><td>43</td><td>42</td><td></td><td></td><td></td><td></td><td></td><td></td><td>36</td><td>35</td><td>34</td></tr> <tr><td></td><td></td><td></td><td></td><td>31</td><td></td><td>28</td><td>26</td><td></td><td></td><td></td><td></td><td></td><td></td><td>21</td><td>20</td><td>19</td></tr> <tr><td></td><td></td><td></td><td></td><td>16</td><td>15</td><td></td><td>12</td><td>10</td><td>9</td><td></td><td></td><td></td><td></td><td>5</td><td></td><td>2</td></tr> <tr><td></td><td></td><td></td><td></td><td></td><td></td><td></td><td></td><td></td><td></td><td></td><td></td><td></td><td></td><td></td><td></td><td>1</td></tr> </table>	72	70			66		63	62							56	55	54	52		49				43	42							36	35	34					31		28	26							21	20	19					16	15		12	10	9					5		2																	1
72	70			66		63	62							56	55	54																																																																												
52		49				43	42							36	35	34																																																																												
				31		28	26							21	20	19																																																																												
				16	15		12	10	9					5		2																																																																												
																1																																																																												
SALEABLE	NOT APPLICABLE	34566-3533	G	9	A	BLACK	<table border="1"> <tr><td></td><td></td><td>69</td><td></td><td></td><td></td><td>63</td><td></td><td></td><td></td><td></td><td></td><td></td><td>58</td><td>56</td><td>55</td><td>54</td><td>53</td></tr> <tr><td>52</td><td>51</td><td>49</td><td></td><td></td><td></td><td>44</td><td>43</td><td>42</td><td>41</td><td></td><td></td><td></td><td></td><td>36</td><td>35</td><td>34</td><td>33</td></tr> <tr><td></td><td></td><td></td><td></td><td>32</td><td></td><td>28</td><td>26</td><td></td><td></td><td></td><td></td><td></td><td></td><td></td><td>19</td><td>18</td><td>17</td></tr> <tr><td></td><td></td><td></td><td></td><td>16</td><td></td><td>12</td><td>10</td><td></td><td></td><td></td><td></td><td></td><td></td><td></td><td>3</td><td>2</td><td>1</td></tr> </table>			69				63							58	56	55	54	53	52	51	49				44	43	42	41					36	35	34	33					32		28	26								19	18	17					16		12	10								3	2	1													
		69				63							58	56	55	54	53																																																																											
52	51	49				44	43	42	41					36	35	34	33																																																																											
				32		28	26								19	18	17																																																																											
				16		12	10								3	2	1																																																																											
AVAILABLE	NOT APPLICABLE	34566-3543	G	9	A	BLACK	<table border="1"> <tr><td>72</td><td>70</td><td></td><td></td><td>66</td><td></td><td>63</td><td>62</td><td></td><td></td><td></td><td></td><td></td><td>59</td><td>57</td><td>56</td><td>55</td><td>53</td></tr> <tr><td>52</td><td>51</td><td></td><td></td><td>46</td><td>44</td><td>42</td><td>41</td><td></td><td></td><td></td><td></td><td></td><td>40</td><td>39</td><td></td><td></td><td>34</td><td>33</td></tr> <tr><td></td><td></td><td></td><td></td><td>30</td><td></td><td>26</td><td>25</td><td></td><td></td><td></td><td></td><td></td><td>22</td><td>21</td><td></td><td></td><td></td><td></td></tr> <tr><td></td><td></td><td></td><td></td><td>15</td><td>14</td><td></td><td>10</td><td>9</td><td></td><td></td><td></td><td></td><td>6</td><td></td><td></td><td></td><td></td><td></td></tr> </table>	72	70			66		63	62						59	57	56	55	53	52	51			46	44	42	41						40	39			34	33					30		26	25						22	21									15	14		10	9					6															
72	70			66		63	62						59	57	56	55	53																																																																											
52	51			46	44	42	41						40	39			34	33																																																																										
				30		26	25						22	21																																																																														
				15	14		10	9					6																																																																															
AVAILABLE	NOT APPLICABLE	34566-3553	G	9	C	BLUE	<table border="1"> <tr><td>72</td><td>71</td><td>70</td><td>69</td><td>68</td><td>67</td><td>66</td><td>65</td><td>63</td><td>62</td><td>61</td><td>59</td><td>58</td><td>57</td><td>56</td><td>55</td><td>54</td><td>53</td></tr> <tr><td>52</td><td>51</td><td>50</td><td>49</td><td>48</td><td>46</td><td>45</td><td>44</td><td>43</td><td>42</td><td>41</td><td>40</td><td>39</td><td>38</td><td>36</td><td>35</td><td>34</td><td>33</td></tr> <tr><td></td><td></td><td></td><td></td><td>31</td><td>30</td><td>29</td><td>28</td><td>27</td><td>26</td><td>25</td><td>22</td><td>20</td><td>19</td><td>18</td><td>17</td><td></td><td></td></tr> <tr><td></td><td></td><td></td><td></td><td>16</td><td>15</td><td>14</td><td></td><td>11</td><td>10</td><td>9</td><td>7</td><td>6</td><td>5</td><td>3</td><td>2</td><td>1</td><td></td></tr> </table>	72	71	70	69	68	67	66	65	63	62	61	59	58	57	56	55	54	53	52	51	50	49	48	46	45	44	43	42	41	40	39	38	36	35	34	33					31	30	29	28	27	26	25	22	20	19	18	17							16	15	14		11	10	9	7	6	5	3	2	1														
72	71	70	69	68	67	66	65	63	62	61	59	58	57	56	55	54	53																																																																											
52	51	50	49	48	46	45	44	43	42	41	40	39	38	36	35	34	33																																																																											
				31	30	29	28	27	26	25	22	20	19	18	17																																																																													
				16	15	14		11	10	9	7	6	5	3	2	1																																																																												
AVAILABLE	NOT APPLICABLE	34566-3563	G	9	C	BLUE	<table border="1"> <tr><td>72</td><td>70</td><td>68</td><td>67</td><td>66</td><td></td><td>63</td><td>62</td><td></td><td></td><td></td><td>59</td><td>57</td><td></td><td></td><td></td><td></td><td>53</td></tr> <tr><td>52</td><td>51</td><td></td><td>48</td><td>47</td><td>46</td><td>44</td><td>42</td><td></td><td></td><td></td><td>40</td><td>39</td><td>38</td><td></td><td></td><td></td><td>34</td><td>33</td></tr> <tr><td></td><td></td><td></td><td>32</td><td></td><td>30</td><td></td><td>27</td><td>26</td><td>25</td><td></td><td></td><td></td><td>22</td><td>21</td><td></td><td></td><td></td><td></td></tr> <tr><td></td><td></td><td></td><td>15</td><td>14</td><td></td><td></td><td>10</td><td>9</td><td></td><td></td><td>6</td><td>5</td><td>4</td><td></td><td></td><td></td><td></td><td></td></tr> </table>	72	70	68	67	66		63	62				59	57					53	52	51		48	47	46	44	42				40	39	38				34	33				32		30		27	26	25				22	21								15	14			10	9			6	5	4															
72	70	68	67	66		63	62				59	57					53																																																																											
52	51		48	47	46	44	42				40	39	38				34	33																																																																										
			32		30		27	26	25				22	21																																																																														
			15	14			10	9			6	5	4																																																																															
AVAILABLE	NOT APPLICABLE	34566-3573	G	9	C	BLUE	<table border="1"> <tr><td></td><td>70</td><td>69</td><td>68</td><td></td><td></td><td></td><td>63</td><td>62</td><td>61</td><td></td><td></td><td></td><td>58</td><td>57</td><td>56</td><td>55</td><td>54</td><td>53</td></tr> <tr><td>52</td><td>51</td><td>50</td><td>49</td><td>48</td><td>47</td><td></td><td>44</td><td>43</td><td>42</td><td>41</td><td></td><td></td><td></td><td>37</td><td>36</td><td></td><td>34</td><td></td></tr> <tr><td></td><td></td><td></td><td></td><td>32</td><td></td><td></td><td>29</td><td>28</td><td>27</td><td>26</td><td></td><td></td><td></td><td></td><td></td><td></td><td>19</td><td>18</td></tr> <tr><td></td><td></td><td></td><td></td><td>16</td><td>15</td><td>14</td><td>13</td><td>12</td><td>11</td><td>10</td><td></td><td></td><td></td><td></td><td></td><td></td><td>3</td><td></td></tr> </table>		70	69	68				63	62	61				58	57	56	55	54	53	52	51	50	49	48	47		44	43	42	41				37	36		34						32			29	28	27	26							19	18					16	15	14	13	12	11	10							3										
	70	69	68				63	62	61				58	57	56	55	54	53																																																																										
52	51	50	49	48	47		44	43	42	41				37	36		34																																																																											
				32			29	28	27	26							19	18																																																																										
				16	15	14	13	12	11	10							3																																																																											
AVAILABLE	NOT APPLICABLE	34566-3583	G	9	A	BLACK	<table border="1"> <tr><td></td><td>70</td><td>69</td><td></td><td></td><td></td><td></td><td>63</td><td>62</td><td>61</td><td></td><td></td><td></td><td>58</td><td>57</td><td>56</td><td>55</td><td>54</td><td>53</td></tr> <tr><td>52</td><td>51</td><td>50</td><td>49</td><td></td><td></td><td></td><td>44</td><td>43</td><td>42</td><td>41</td><td></td><td></td><td></td><td>37</td><td>36</td><td></td><td>34</td><td></td></tr> <tr><td></td><td></td><td></td><td></td><td>32</td><td></td><td></td><td>29</td><td>28</td><td>27</td><td>26</td><td></td><td></td><td></td><td></td><td></td><td></td><td>19</td><td>18</td></tr> <tr><td></td><td></td><td></td><td></td><td>16</td><td>15</td><td>14</td><td>13</td><td>12</td><td>11</td><td>10</td><td></td><td></td><td></td><td></td><td></td><td></td><td>3</td><td></td></tr> </table>		70	69					63	62	61				58	57	56	55	54	53	52	51	50	49				44	43	42	41				37	36		34						32			29	28	27	26							19	18					16	15	14	13	12	11	10							3										
	70	69					63	62	61				58	57	56	55	54	53																																																																										
52	51	50	49				44	43	42	41				37	36		34																																																																											
				32			29	28	27	26							19	18																																																																										
				16	15	14	13	12	11	10							3																																																																											
AVAILABLE	NOT APPLICABLE	34566-3593	G	0	A	BLACK	<table border="1"> <tr><td></td><td>71</td><td>69</td><td></td><td></td><td></td><td></td><td>64</td><td>63</td><td></td><td></td><td>60</td><td></td><td>58</td><td>57</td><td>56</td><td>55</td><td>54</td><td>53</td></tr> <tr><td>52</td><td>51</td><td>49</td><td></td><td></td><td></td><td></td><td>45</td><td>44</td><td>43</td><td>42</td><td>41</td><td></td><td></td><td>37</td><td>36</td><td>35</td><td>34</td><td>33</td></tr> <tr><td></td><td></td><td></td><td></td><td>32</td><td>30</td><td></td><td>28</td><td>27</td><td>26</td><td></td><td></td><td></td><td></td><td></td><td></td><td></td><td>19</td><td>18</td></tr> <tr><td></td><td></td><td></td><td></td><td>16</td><td>15</td><td></td><td>12</td><td>10</td><td></td><td></td><td></td><td></td><td></td><td></td><td></td><td></td><td>3</td><td></td></tr> </table>		71	69					64	63			60		58	57	56	55	54	53	52	51	49					45	44	43	42	41			37	36	35	34	33					32	30		28	27	26								19	18					16	15		12	10									3										
	71	69					64	63			60		58	57	56	55	54	53																																																																										
52	51	49					45	44	43	42	41			37	36	35	34	33																																																																										
				32	30		28	27	26								19	18																																																																										
				16	15		12	10									3																																																																											
AVAILABLE	NOT APPLICABLE	34566-3613	G	0	B	ST GRY	<table border="1"> <tr><td></td><td></td><td></td><td>68</td><td>67</td><td></td><td></td><td>64</td><td>63</td><td></td><td></td><td></td><td></td><td>59</td><td></td><td></td><td></td><td></td><td></td></tr> <tr><td></td><td></td><td></td><td>46</td><td>45</td><td></td><td></td><td>43</td><td></td><td></td><td></td><td></td><td></td><td>39</td><td></td><td></td><td></td><td></td><td></td></tr> <tr><td></td><td></td><td></td><td>32</td><td>30</td><td>29</td><td>28</td><td>27</td><td></td><td></td><td></td><td></td><td></td><td></td><td></td><td></td><td></td><td></td><td></td></tr> <tr><td></td><td></td><td></td><td></td><td></td><td></td><td></td><td></td><td>10</td><td></td><td></td><td></td><td></td><td>6</td><td>5</td><td>4</td><td>3</td><td></td><td></td></tr> </table>				68	67			64	63					59									46	45			43						39									32	30	29	28	27																				10					6	5	4	3											
			68	67			64	63					59																																																																															
			46	45			43						39																																																																															
			32	30	29	28	27																																																																																					
								10					6	5	4	3																																																																												

ENTER DESCRIPTION IEC NO: UAU2014-0574 DRAWNSKRA JENDRANA 2013/10/08 CHKD: SKRA APPR: IKOSHY 2013/10/09 REV:	QUALITY SYMBOLS ∇=0 ∇=0 ∇=0	GENERAL TOLERANCES (UNLESS SPECIFIED) mm INCH 4 PLACES ± --- ± --- 3 PLACES ± --- ± --- 2 PLACES ± --- ± --- 1 PLACE ± --- ± --- 0 PLACE ± --- ± ---	DIMENSION STYLE MM ONLY	SCALE DESIGN UNITS METRIC	THIRD ANGLE PROJECTION	
	DRAWN BY: SKRA JENDRANA 2011/02/14 CHECKED BY: MVANSLAMBROU 2011/02/14 APPROVED BY:	DATE:	TITLE:	MX123 66/73/80CKT HRNS CONN ASSY	MATERIAL NO. SD-34566-001	DOCUMENT NO.
	ANGULAR ± --- ° DRAFT WHERE APPLICABLE MUST REMAIN WITHIN DIMENSIONS	SEE BOM TABLE	SHEET NO. 42 OF 68	THIS DRAWING CONTAINS INFORMATION THAT IS PROPRIETARY TO MOLEX INCORPORATED AND SHOULD NOT BE USED WITHOUT WRITTEN PERMISSION		

STATUS	GM PART #	MATERIAL #	PART/MATERIAL REVISION	WIRE DRESS OPTION	KEY OPTION	COLOR (TPA)	NUMBERS INDICATE CAVITIES OPEN FOR CIRCUITS																																																																																					
AVAILABLE	NOT APPLICABLE	34566-3913	G	0	A	BLACK	<table border="1"> <tr><td>71</td><td>70</td><td>69</td><td></td><td></td><td></td><td>64</td><td>63</td><td></td><td>60</td><td>58</td><td>57</td><td>56</td><td>55</td><td>54</td><td>53</td></tr> <tr><td>52</td><td>51</td><td>49</td><td></td><td></td><td></td><td>45</td><td>44</td><td>43</td><td>42</td><td>41</td><td></td><td></td><td>37</td><td>36</td><td>34</td></tr> <tr><td></td><td></td><td></td><td>32</td><td>30</td><td></td><td>28</td><td>26</td><td></td><td></td><td>23</td><td></td><td></td><td>21</td><td>19</td><td>18</td></tr> <tr><td></td><td></td><td></td><td>16</td><td>15</td><td></td><td>12</td><td>10</td><td></td><td></td><td>8</td><td></td><td></td><td>5</td><td>3</td><td></td></tr> <tr><td></td><td></td><td></td><td></td><td></td><td></td><td></td><td></td><td></td><td></td><td></td><td></td><td></td><td></td><td></td><td></td></tr> </table>	71	70	69				64	63		60	58	57	56	55	54	53	52	51	49				45	44	43	42	41			37	36	34				32	30		28	26			23			21	19	18				16	15		12	10			8			5	3																						
71	70	69				64	63		60	58	57	56	55	54	53																																																																													
52	51	49				45	44	43	42	41			37	36	34																																																																													
			32	30		28	26			23			21	19	18																																																																													
			16	15		12	10			8			5	3																																																																														
AVAILABLE	NOT APPLICABLE	34566-3923	G	0	B	ST GRAY	<table border="1"> <tr><td>72</td><td>70</td><td>68</td><td>66</td><td></td><td></td><td></td><td></td><td></td><td>60</td><td>59</td><td></td><td></td><td>55</td><td>54</td><td>53</td></tr> <tr><td>52</td><td></td><td>50</td><td>48</td><td>46</td><td></td><td></td><td></td><td></td><td>40</td><td>39</td><td></td><td></td><td>35</td><td>34</td><td>33</td></tr> <tr><td></td><td></td><td></td><td>32</td><td>31</td><td>30</td><td>29</td><td>28</td><td>27</td><td>26</td><td>25</td><td>24</td><td>23</td><td></td><td>19</td><td>18</td></tr> <tr><td></td><td></td><td></td><td>16</td><td></td><td></td><td></td><td></td><td></td><td>10</td><td>9</td><td>8</td><td>7</td><td></td><td></td><td></td></tr> <tr><td></td><td></td><td></td><td></td><td></td><td></td><td></td><td></td><td></td><td></td><td></td><td></td><td></td><td></td><td></td><td></td></tr> </table>	72	70	68	66						60	59			55	54	53	52		50	48	46					40	39			35	34	33				32	31	30	29	28	27	26	25	24	23		19	18				16						10	9	8	7																								
72	70	68	66						60	59			55	54	53																																																																													
52		50	48	46					40	39			35	34	33																																																																													
			32	31	30	29	28	27	26	25	24	23		19	18																																																																													
			16						10	9	8	7																																																																																
AVAILABLE	NOT APPLICABLE	34566-3933	G	0	A	BLACK	<table border="1"> <tr><td>71</td><td>70</td><td>69</td><td></td><td></td><td></td><td>64</td><td>63</td><td></td><td>60</td><td>58</td><td>57</td><td>56</td><td>55</td><td>54</td><td>53</td></tr> <tr><td>52</td><td>51</td><td>49</td><td></td><td></td><td></td><td>45</td><td>44</td><td>43</td><td>42</td><td>41</td><td></td><td></td><td></td><td></td><td>34</td></tr> <tr><td></td><td></td><td></td><td>32</td><td>30</td><td></td><td>28</td><td>26</td><td></td><td></td><td></td><td></td><td></td><td></td><td>19</td><td>18</td></tr> <tr><td></td><td></td><td></td><td>16</td><td>15</td><td></td><td>12</td><td>10</td><td></td><td></td><td></td><td></td><td></td><td></td><td>3</td><td></td></tr> <tr><td></td><td></td><td></td><td></td><td></td><td></td><td></td><td></td><td></td><td></td><td></td><td></td><td></td><td></td><td></td><td></td></tr> </table>	71	70	69				64	63		60	58	57	56	55	54	53	52	51	49				45	44	43	42	41					34				32	30		28	26							19	18				16	15		12	10							3																						
71	70	69				64	63		60	58	57	56	55	54	53																																																																													
52	51	49				45	44	43	42	41					34																																																																													
			32	30		28	26							19	18																																																																													
			16	15		12	10							3																																																																														
AVAILABLE	NOT APPLICABLE	34566-3943	G	0	C	BLUE	<table border="1"> <tr><td>72</td><td>70</td><td>68</td><td>66</td><td></td><td></td><td></td><td></td><td></td><td>60</td><td>59</td><td></td><td></td><td>55</td><td>54</td><td>53</td></tr> <tr><td>52</td><td></td><td>50</td><td>48</td><td>46</td><td></td><td></td><td></td><td></td><td>40</td><td>39</td><td></td><td></td><td>35</td><td>34</td><td>33</td></tr> <tr><td></td><td></td><td></td><td>32</td><td>31</td><td>30</td><td>29</td><td>28</td><td>27</td><td>26</td><td>25</td><td>24</td><td></td><td></td><td></td><td></td></tr> <tr><td></td><td></td><td></td><td>16</td><td></td><td></td><td></td><td></td><td></td><td>10</td><td>9</td><td>8</td><td></td><td></td><td></td><td></td></tr> <tr><td></td><td></td><td></td><td></td><td></td><td></td><td></td><td></td><td></td><td></td><td></td><td></td><td></td><td></td><td></td><td></td></tr> </table>	72	70	68	66						60	59			55	54	53	52		50	48	46					40	39			35	34	33				32	31	30	29	28	27	26	25	24								16						10	9	8																									
72	70	68	66						60	59			55	54	53																																																																													
52		50	48	46					40	39			35	34	33																																																																													
			32	31	30	29	28	27	26	25	24																																																																																	
			16						10	9	8																																																																																	
AVAILABLE	NOT APPLICABLE	34566-3953	G	0	C	BLUE	<table border="1"> <tr><td>72</td><td>70</td><td>68</td><td></td><td></td><td></td><td>63</td><td>62</td><td></td><td>59</td><td>57</td><td></td><td></td><td></td><td></td><td>53</td></tr> <tr><td>52</td><td>51</td><td></td><td>48</td><td>47</td><td>46</td><td>44</td><td>42</td><td>40</td><td>39</td><td></td><td></td><td></td><td></td><td></td><td>34</td></tr> <tr><td></td><td></td><td></td><td>32</td><td>30</td><td></td><td></td><td>26</td><td>25</td><td></td><td>23</td><td>22</td><td>21</td><td>20</td><td></td><td></td></tr> <tr><td></td><td></td><td></td><td>15</td><td>14</td><td>13</td><td></td><td></td><td></td><td>7</td><td>6</td><td>5</td><td>4</td><td></td><td></td><td></td></tr> <tr><td></td><td></td><td></td><td></td><td></td><td></td><td></td><td></td><td></td><td></td><td></td><td></td><td></td><td></td><td></td><td></td></tr> </table>	72	70	68				63	62		59	57					53	52	51		48	47	46	44	42	40	39						34				32	30			26	25		23	22	21	20						15	14	13				7	6	5	4																								
72	70	68				63	62		59	57					53																																																																													
52	51		48	47	46	44	42	40	39						34																																																																													
			32	30			26	25		23	22	21	20																																																																															
			15	14	13				7	6	5	4																																																																																
AVAILABLE	NOT APPLICABLE	34566-3963	G	0	C	BLUE	<table border="1"> <tr><td>72</td><td>70</td><td>68</td><td>67</td><td>66</td><td></td><td>63</td><td>62</td><td></td><td>59</td><td>57</td><td></td><td></td><td></td><td></td><td>53</td></tr> <tr><td>52</td><td>51</td><td></td><td>48</td><td>47</td><td>46</td><td>44</td><td>42</td><td>40</td><td>39</td><td>38</td><td></td><td></td><td></td><td></td><td>34</td></tr> <tr><td></td><td></td><td></td><td>32</td><td>30</td><td></td><td></td><td>26</td><td>25</td><td></td><td></td><td>22</td><td>21</td><td></td><td></td><td></td></tr> <tr><td></td><td></td><td></td><td>15</td><td>14</td><td></td><td></td><td>10</td><td>9</td><td></td><td></td><td>6</td><td>5</td><td>4</td><td></td><td></td></tr> <tr><td></td><td></td><td></td><td></td><td></td><td></td><td></td><td></td><td></td><td></td><td></td><td></td><td></td><td></td><td></td><td></td></tr> </table>	72	70	68	67	66		63	62		59	57					53	52	51		48	47	46	44	42	40	39	38					34				32	30			26	25			22	21							15	14			10	9			6	5	4																							
72	70	68	67	66		63	62		59	57					53																																																																													
52	51		48	47	46	44	42	40	39	38					34																																																																													
			32	30			26	25			22	21																																																																																
			15	14			10	9			6	5	4																																																																															
AVAILABLE	NOT APPLICABLE	34566-3973	G	0	C	BLUE	<table border="1"> <tr><td>72</td><td>70</td><td>68</td><td>67</td><td></td><td></td><td>63</td><td>62</td><td></td><td>59</td><td>57</td><td></td><td></td><td></td><td></td><td>53</td></tr> <tr><td>52</td><td>51</td><td></td><td>48</td><td>47</td><td>46</td><td>44</td><td>42</td><td>40</td><td>39</td><td>38</td><td></td><td></td><td></td><td></td><td>34</td></tr> <tr><td></td><td></td><td></td><td>32</td><td>30</td><td></td><td></td><td>26</td><td>25</td><td></td><td></td><td>22</td><td>21</td><td></td><td></td><td></td></tr> <tr><td></td><td></td><td></td><td>15</td><td>14</td><td></td><td></td><td></td><td></td><td></td><td></td><td>6</td><td>5</td><td>4</td><td></td><td></td></tr> <tr><td></td><td></td><td></td><td></td><td></td><td></td><td></td><td></td><td></td><td></td><td></td><td></td><td></td><td></td><td></td><td></td></tr> </table>	72	70	68	67			63	62		59	57					53	52	51		48	47	46	44	42	40	39	38					34				32	30			26	25			22	21							15	14							6	5	4																							
72	70	68	67			63	62		59	57					53																																																																													
52	51		48	47	46	44	42	40	39	38					34																																																																													
			32	30			26	25			22	21																																																																																
			15	14							6	5	4																																																																															
AVAILABLE	NOT APPLICABLE	34566-3983	G	0	A	BLACK	<table border="1"> <tr><td>71</td><td>70</td><td>69</td><td></td><td></td><td></td><td>64</td><td>63</td><td></td><td>60</td><td>59</td><td>58</td><td>57</td><td>56</td><td>55</td><td>54</td><td>53</td></tr> <tr><td>52</td><td>51</td><td>49</td><td></td><td></td><td></td><td>45</td><td>44</td><td>43</td><td>42</td><td>41</td><td>40</td><td></td><td></td><td>37</td><td>36</td><td>34</td></tr> <tr><td></td><td></td><td></td><td>32</td><td>30</td><td></td><td>28</td><td>26</td><td></td><td></td><td></td><td></td><td></td><td></td><td>19</td><td>18</td><td></td></tr> <tr><td></td><td></td><td></td><td>16</td><td>15</td><td></td><td>12</td><td>10</td><td></td><td></td><td></td><td></td><td></td><td></td><td>3</td><td></td><td></td></tr> <tr><td></td><td></td><td></td><td></td><td></td><td></td><td></td><td></td><td></td><td></td><td></td><td></td><td></td><td></td><td></td><td></td><td></td></tr> </table>	71	70	69				64	63		60	59	58	57	56	55	54	53	52	51	49				45	44	43	42	41	40			37	36	34				32	30		28	26							19	18					16	15		12	10							3																			
71	70	69				64	63		60	59	58	57	56	55	54	53																																																																												
52	51	49				45	44	43	42	41	40			37	36	34																																																																												
			32	30		28	26							19	18																																																																													
			16	15		12	10							3																																																																														
AVAILABLE	NOT APPLICABLE	34566-3993	G	0	A	BLACK	<table border="1"> <tr><td></td><td>70</td><td>69</td><td></td><td></td><td></td><td>63</td><td>62</td><td>61</td><td>60</td><td>58</td><td>57</td><td>56</td><td>55</td><td>54</td><td>53</td></tr> <tr><td>52</td><td>51</td><td>49</td><td></td><td></td><td></td><td>44</td><td>43</td><td>42</td><td>41</td><td>40</td><td></td><td></td><td>37</td><td>36</td><td>34</td></tr> <tr><td></td><td></td><td></td><td>32</td><td>30</td><td></td><td>29</td><td>28</td><td>27</td><td>26</td><td></td><td></td><td></td><td></td><td>19</td><td>18</td></tr> <tr><td></td><td></td><td></td><td>16</td><td>15</td><td></td><td>13</td><td>12</td><td>11</td><td>10</td><td></td><td></td><td></td><td></td><td>3</td><td></td></tr> <tr><td></td><td></td><td></td><td></td><td></td><td></td><td></td><td></td><td></td><td></td><td></td><td></td><td></td><td></td><td></td><td></td></tr> </table>		70	69				63	62	61	60	58	57	56	55	54	53	52	51	49				44	43	42	41	40			37	36	34				32	30		29	28	27	26					19	18				16	15		13	12	11	10					3																						
	70	69				63	62	61	60	58	57	56	55	54	53																																																																													
52	51	49				44	43	42	41	40			37	36	34																																																																													
			32	30		29	28	27	26					19	18																																																																													
			16	15		13	12	11	10					3																																																																														

ENTER DESCRIPTION EC NO: UAU2014-0574 DRWN:SKRAJENDRANA 2013/10/08 CHKD: APPR:VKOSHY 2013/10/09 REV:	QUALITY SYMBOLS	GENERAL TOLERANCES (UNLESS SPECIFIED)	DIMENSION STYLE	SCALE	DESIGN UNITS	THIRD ANGLE PROJECTION	
	∇=0 ∇=0 ∇=0	4 PLACES ±---- 3 PLACES ±---- 2 PLACES ±---- 1 PLACE ±---- 0 PLACE ±----	mm INCH +---- +---- +---- +---- +---- +---- +---- +----	MM ONLY DRAWN BY: SKRAJENDRANA 2011/02/14 CHECKED BY: MVANSLAMBROU 2011/02/14 APPROVED BY:	DATE: 2011/02/14 DATE: 2011/02/14 DATE:	METRIC MX123 66/73/80CKT HRNS CONN ASSY	THIRD ANGLE PROJECTION
	ANGULAR ±----° DRAFT WHERE APPLICABLE MUST REMAIN WITHIN DIMENSIONS	SEE BOM TABLE	MATERIAL NO. DOCUMENT NO.	SD-34566-001	SHEET NO. 46 OF 68		
	THIS DRAWING CONTAINS INFORMATION THAT IS PROPRIETARY TO MOLEX INCORPORATED AND SHOULD NOT BE USED WITHOUT WRITTEN PERMISSION						

STATUS	GM PART #	MATERIAL #	PART/MATERIAL REVISION	WIRE DRESS OPTION	KEY OPTION	COLOR (TPA)	NUMBERS INDICATE CAVITIES OPEN FOR CIRCUITS																																																																											
AVAILABLE	NOT APPLICABLE	34566-4013	G	0	B	ST GRAY	<table border="1"> <tr><td>72</td><td>70</td><td>68</td><td>66</td><td></td><td></td><td></td><td></td><td>60</td><td>59</td><td></td><td></td><td>55</td><td>54</td><td>53</td></tr> <tr><td>52</td><td>50</td><td>48</td><td>46</td><td></td><td></td><td></td><td></td><td>40</td><td>39</td><td></td><td></td><td>35</td><td>34</td><td>33</td></tr> <tr><td colspan="2">73</td><td>32</td><td>31</td><td>30</td><td>29</td><td>28</td><td>27</td><td>26</td><td>25</td><td>24</td><td></td><td></td><td></td><td>17</td></tr> <tr><td colspan="2"></td><td>16</td><td></td><td></td><td></td><td></td><td></td><td>10</td><td>8</td><td></td><td></td><td></td><td></td><td>2</td><td>1</td></tr> </table>	72	70	68	66					60	59			55	54	53	52	50	48	46					40	39			35	34	33	73		32	31	30	29	28	27	26	25	24				17			16						10	8					2	1														
72	70	68	66					60	59			55	54	53																																																																				
52	50	48	46					40	39			35	34	33																																																																				
73		32	31	30	29	28	27	26	25	24				17																																																																				
		16						10	8					2	1																																																																			
AVAILABLE	NOT APPLICABLE	34566-4023	G	0	B	ST GRAY	<table border="1"> <tr><td>72</td><td>71</td><td>70</td><td>68</td><td>67</td><td>66</td><td></td><td></td><td>62</td><td>61</td><td>60</td><td>59</td><td>58</td><td>57</td><td>56</td><td>55</td><td>54</td><td>53</td></tr> <tr><td>52</td><td>51</td><td>50</td><td>48</td><td>47</td><td>46</td><td></td><td></td><td>42</td><td>41</td><td>40</td><td>39</td><td>38</td><td>37</td><td>36</td><td>35</td><td>34</td><td>33</td></tr> <tr><td colspan="2">73</td><td>32</td><td>31</td><td>30</td><td>29</td><td>28</td><td>27</td><td>26</td><td>25</td><td>24</td><td></td><td></td><td></td><td></td><td></td><td></td><td></td></tr> <tr><td colspan="2"></td><td>16</td><td>15</td><td>14</td><td>13</td><td></td><td></td><td>10</td><td>9</td><td>8</td><td></td><td></td><td></td><td></td><td></td><td></td><td></td></tr> </table>	72	71	70	68	67	66			62	61	60	59	58	57	56	55	54	53	52	51	50	48	47	46			42	41	40	39	38	37	36	35	34	33	73		32	31	30	29	28	27	26	25	24										16	15	14	13			10	9	8										
72	71	70	68	67	66			62	61	60	59	58	57	56	55	54	53																																																																	
52	51	50	48	47	46			42	41	40	39	38	37	36	35	34	33																																																																	
73		32	31	30	29	28	27	26	25	24																																																																								
		16	15	14	13			10	9	8																																																																								
AVAILABLE	NOT APPLICABLE	34566-4033	G	0	C	BLUE	<table border="1"> <tr><td>72</td><td>70</td><td>68</td><td></td><td></td><td></td><td></td><td>63</td><td>62</td><td></td><td>59</td><td>58</td><td>57</td><td></td><td></td><td></td><td></td><td>53</td></tr> <tr><td>52</td><td>51</td><td></td><td>48</td><td>47</td><td></td><td>44</td><td>42</td><td>41</td><td>40</td><td>39</td><td>38</td><td></td><td></td><td></td><td></td><td></td><td>34</td><td>33</td></tr> <tr><td colspan="2">73</td><td></td><td>32</td><td></td><td>30</td><td></td><td></td><td>26</td><td>25</td><td></td><td></td><td>22</td><td>21</td><td>20</td><td></td><td></td><td></td><td>17</td></tr> <tr><td colspan="2"></td><td></td><td>15</td><td>14</td><td>13</td><td></td><td></td><td></td><td></td><td></td><td></td><td>6</td><td>5</td><td>4</td><td></td><td></td><td></td><td>1</td></tr> </table>	72	70	68					63	62		59	58	57					53	52	51		48	47		44	42	41	40	39	38						34	33	73			32		30			26	25			22	21	20				17				15	14	13							6	5	4				1
72	70	68					63	62		59	58	57					53																																																																	
52	51		48	47		44	42	41	40	39	38						34	33																																																																
73			32		30			26	25			22	21	20				17																																																																
			15	14	13							6	5	4				1																																																																
AVAILABLE	NOT APPLICABLE	34566-4043	G	0	A	BLACK	<table border="1"> <tr><td></td><td>71</td><td>70</td><td>69</td><td></td><td>67</td><td></td><td>64</td><td>63</td><td></td><td>60</td><td></td><td></td><td>57</td><td>56</td><td>55</td><td>54</td><td>53</td></tr> <tr><td>52</td><td>51</td><td></td><td>49</td><td></td><td></td><td>45</td><td>44</td><td>43</td><td>42</td><td>41</td><td></td><td></td><td>37</td><td>36</td><td></td><td></td><td>34</td></tr> <tr><td colspan="2">73</td><td></td><td>32</td><td></td><td>30</td><td></td><td>28</td><td>26</td><td></td><td></td><td>23</td><td></td><td></td><td></td><td>19</td><td>18</td><td></td></tr> <tr><td colspan="2"></td><td></td><td>16</td><td>15</td><td></td><td></td><td>12</td><td>10</td><td></td><td></td><td></td><td></td><td></td><td></td><td>3</td><td></td><td></td></tr> </table>		71	70	69		67		64	63		60			57	56	55	54	53	52	51		49			45	44	43	42	41			37	36			34	73			32		30		28	26			23				19	18					16	15			12	10							3					
	71	70	69		67		64	63		60			57	56	55	54	53																																																																	
52	51		49			45	44	43	42	41			37	36			34																																																																	
73			32		30		28	26			23				19	18																																																																		
			16	15			12	10							3																																																																			
AVAILABLE	NOT APPLICABLE	34566-4053	G	0	A	BLACK	<table border="1"> <tr><td>72</td><td></td><td></td><td>69</td><td>67</td><td>66</td><td>65</td><td>63</td><td></td><td>60</td><td></td><td></td><td>57</td><td>56</td><td></td><td></td><td></td><td>53</td></tr> <tr><td></td><td></td><td></td><td>49</td><td></td><td>47</td><td>46</td><td>44</td><td>43</td><td>42</td><td>40</td><td></td><td>37</td><td>36</td><td>35</td><td></td><td></td><td>33</td></tr> <tr><td colspan="2">73</td><td></td><td>31</td><td>30</td><td>29</td><td>28</td><td>27</td><td>26</td><td>24</td><td></td><td></td><td>21</td><td>20</td><td></td><td></td><td></td><td>17</td></tr> <tr><td colspan="2"></td><td></td><td>16</td><td>15</td><td>14</td><td>13</td><td></td><td>11</td><td>10</td><td></td><td></td><td>5</td><td>4</td><td>3</td><td>2</td><td>1</td><td></td></tr> </table>	72			69	67	66	65	63		60			57	56				53				49		47	46	44	43	42	40		37	36	35			33	73			31	30	29	28	27	26	24			21	20				17				16	15	14	13		11	10			5	4	3	2	1				
72			69	67	66	65	63		60			57	56				53																																																																	
			49		47	46	44	43	42	40		37	36	35			33																																																																	
73			31	30	29	28	27	26	24			21	20				17																																																																	
			16	15	14	13		11	10			5	4	3	2	1																																																																		
AVAILABLE	NOT APPLICABLE	34566-4063	G	0	B	ST GRAY	<table border="1"> <tr><td></td><td></td><td></td><td>68</td><td>67</td><td></td><td></td><td>64</td><td></td><td></td><td>59</td><td>58</td><td></td><td></td><td></td><td></td><td></td><td>54</td></tr> <tr><td></td><td></td><td></td><td></td><td>46</td><td>45</td><td></td><td></td><td></td><td></td><td>39</td><td>38</td><td></td><td></td><td></td><td></td><td></td><td>17</td></tr> <tr><td colspan="2">73</td><td></td><td>32</td><td></td><td>30</td><td>29</td><td>28</td><td>27</td><td></td><td></td><td>23</td><td>22</td><td></td><td></td><td></td><td></td><td>1</td></tr> <tr><td colspan="2"></td><td></td><td>15</td><td></td><td>13</td><td></td><td></td><td>10</td><td>8</td><td></td><td></td><td></td><td></td><td></td><td></td><td></td><td></td></tr> </table>				68	67			64			59	58						54					46	45					39	38						17	73			32		30	29	28	27			23	22					1				15		13			10	8											
			68	67			64			59	58						54																																																																	
				46	45					39	38						17																																																																	
73			32		30	29	28	27			23	22					1																																																																	
			15		13			10	8																																																																									
AVAILABLE	NOT APPLICABLE	34566-4073	G	0	A	BLACK	<table border="1"> <tr><td>72</td><td>70</td><td></td><td></td><td></td><td>66</td><td></td><td>63</td><td>62</td><td></td><td>59</td><td></td><td>57</td><td>56</td><td>55</td><td></td><td></td><td>53</td></tr> <tr><td>52</td><td>51</td><td></td><td></td><td></td><td>46</td><td>44</td><td>42</td><td>41</td><td>40</td><td>39</td><td></td><td>37</td><td>36</td><td></td><td></td><td></td><td>34</td><td>33</td></tr> <tr><td colspan="2">73</td><td></td><td>32</td><td></td><td>30</td><td></td><td></td><td>26</td><td>25</td><td></td><td></td><td>22</td><td>21</td><td>19</td><td>18</td><td></td><td></td><td></td></tr> <tr><td colspan="2"></td><td></td><td>15</td><td>14</td><td></td><td></td><td></td><td>10</td><td>9</td><td></td><td></td><td>6</td><td></td><td>3</td><td></td><td></td><td></td><td></td></tr> </table>	72	70				66		63	62		59		57	56	55			53	52	51				46	44	42	41	40	39		37	36				34	33	73			32		30			26	25			22	21	19	18							15	14				10	9			6		3				
72	70				66		63	62		59		57	56	55			53																																																																	
52	51				46	44	42	41	40	39		37	36				34	33																																																																
73			32		30			26	25			22	21	19	18																																																																			
			15	14				10	9			6		3																																																																				

ENTER DESCRIPTION IEC NO: UAU2014-0574 DRWNS:SKRAJENDRANA 2013/10/08 CHKD: APPR:WKSHY 2013/10/09 REY:	QUALITY SYMBOLS	GENERAL TOLERANCES (UNLESS SPECIFIED)	DIMENSION STYLE	SCALE	DESIGN UNITS	THIRD ANGLE PROJECTION
	▽=0	mm INCH	MM ONLY		METRIC	
	▽=0	4 PLACES ± --- ± ---	DRAWN BY SKRAJENDRANA 2011/02/14	DATE	TITLE	
	▽=0	3 PLACES ± --- ± ---	CHECKED BY MVANSLAMBROU 2011/02/14	DATE		
	2 PLACES ± --- ± ---	APPROVED BY	DATE			
	1 PLACE ± --- ± ---	MATERIAL NO.	DOCUMENT NO.			
	0 PLACE ± --- ± ---	ANGULAR ± ---°	SEE BOM TABLE			
		DRAFT WHERE APPLICABLE MUST REMAIN WITHIN DIMENSIONS				

MX123
66/73/80CKT
HRNS CONN ASSY
molex

SD-34566-001

SHEET NO. 47 OF 68

STATUS	GM PART #	MATERIAL #	PART/MATERIAL REVISION	WIRE DRESS OPTION	KEY OPTION	COLOR (TPA)	NUMBERS INDICATE CAVITIES OPEN FOR CIRCUITS																																																																																
AVAILABLE	NOT APPLICABLE	34566-4083	G	0	C	BLUE	<table border="1"> <tr><td>72</td><td>70</td><td>68</td><td></td><td></td><td></td><td>63</td><td>62</td><td></td><td></td><td>59</td><td>58</td><td>57</td><td></td><td></td><td>53</td></tr> <tr><td>52</td><td>51</td><td></td><td>48</td><td>47</td><td></td><td>44</td><td>42</td><td></td><td>40</td><td>39</td><td>38</td><td>37</td><td>36</td><td></td><td>34</td><td>33</td></tr> <tr><td></td><td></td><td>73</td><td></td><td>32</td><td></td><td>30</td><td></td><td></td><td>27</td><td>26</td><td>25</td><td>24</td><td></td><td>22</td><td>21</td><td>20</td><td>17</td></tr> <tr><td></td><td></td><td></td><td></td><td>15</td><td></td><td>14</td><td>13</td><td></td><td></td><td></td><td>8</td><td></td><td>6</td><td>5</td><td>4</td><td></td><td>2</td><td>1</td></tr> </table>	72	70	68				63	62			59	58	57			53	52	51		48	47		44	42		40	39	38	37	36		34	33			73		32		30			27	26	25	24		22	21	20	17					15		14	13				8		6	5	4		2	1										
72	70	68				63	62			59	58	57			53																																																																								
52	51		48	47		44	42		40	39	38	37	36		34	33																																																																							
		73		32		30			27	26	25	24		22	21	20	17																																																																						
				15		14	13				8		6	5	4		2	1																																																																					
AVAILABLE	NOT APPLICABLE	34566-4093	G	0	A	BLACK	<table border="1"> <tr><td></td><td>71</td><td>70</td><td>69</td><td></td><td>67</td><td></td><td></td><td>64</td><td>63</td><td></td><td></td><td>60</td><td></td><td></td><td>57</td><td>56</td><td>55</td><td>54</td><td>53</td></tr> <tr><td>52</td><td>51</td><td></td><td>49</td><td></td><td>47</td><td></td><td>45</td><td>44</td><td>43</td><td>42</td><td>41</td><td></td><td></td><td></td><td>37</td><td>36</td><td></td><td>34</td><td></td></tr> <tr><td></td><td></td><td>73</td><td></td><td>32</td><td></td><td>30</td><td></td><td>28</td><td></td><td>26</td><td></td><td></td><td>23</td><td></td><td></td><td></td><td>19</td><td>18</td><td></td></tr> <tr><td></td><td></td><td></td><td></td><td>16</td><td></td><td>15</td><td></td><td>12</td><td></td><td>10</td><td></td><td></td><td></td><td></td><td></td><td></td><td>3</td><td></td><td></td></tr> </table>		71	70	69		67			64	63			60			57	56	55	54	53	52	51		49		47		45	44	43	42	41				37	36		34				73		32		30		28		26			23				19	18						16		15		12		10							3		
	71	70	69		67			64	63			60			57	56	55	54	53																																																																				
52	51		49		47		45	44	43	42	41				37	36		34																																																																					
		73		32		30		28		26			23				19	18																																																																					
				16		15		12		10							3																																																																						
AVAILABLE	NOT APPLICABLE	34566-4113	G	0	B	ST GRAY	<table border="1"> <tr><td></td><td></td><td></td><td>68</td><td>67</td><td></td><td>64</td><td></td><td></td><td></td><td></td><td></td><td></td><td></td><td>58</td><td></td><td></td><td></td><td></td><td></td></tr> <tr><td></td><td></td><td></td><td></td><td></td><td>46</td><td>45</td><td></td><td></td><td></td><td></td><td></td><td></td><td></td><td>38</td><td></td><td></td><td></td><td></td><td></td></tr> <tr><td></td><td></td><td>73</td><td></td><td>32</td><td></td><td>30</td><td>29</td><td>28</td><td>27</td><td></td><td></td><td></td><td></td><td>22</td><td></td><td></td><td></td><td></td><td>17</td></tr> <tr><td></td><td></td><td></td><td></td><td>15</td><td></td><td>13</td><td></td><td></td><td>10</td><td></td><td></td><td></td><td></td><td></td><td></td><td></td><td></td><td></td><td>1</td></tr> </table>				68	67		64								58											46	45								38								73		32		30	29	28	27					22					17					15		13			10										1
			68	67		64								58																																																																									
					46	45								38																																																																									
		73		32		30	29	28	27					22					17																																																																				
				15		13			10										1																																																																				
AVAILABLE	NOT APPLICABLE	34566-4123	G	9	A	BLACK	<table border="1"> <tr><td>72</td><td></td><td>69</td><td></td><td>67</td><td>66</td><td>65</td><td></td><td>63</td><td></td><td>60</td><td></td><td></td><td>57</td><td>56</td><td></td><td></td><td>53</td><td></td><td></td></tr> <tr><td></td><td></td><td>49</td><td></td><td>47</td><td>46</td><td></td><td>44</td><td>43</td><td>42</td><td>40</td><td></td><td></td><td>37</td><td>36</td><td>35</td><td></td><td>33</td><td></td><td></td></tr> <tr><td></td><td></td><td>73</td><td></td><td>31</td><td>30</td><td>29</td><td>28</td><td></td><td>26</td><td>24</td><td></td><td></td><td>21</td><td>20</td><td></td><td></td><td>17</td><td></td><td></td></tr> <tr><td></td><td></td><td></td><td></td><td>16</td><td>15</td><td>14</td><td>13</td><td></td><td>11</td><td>10</td><td></td><td></td><td></td><td>5</td><td>4</td><td>3</td><td>2</td><td>1</td><td></td></tr> </table>	72		69		67	66	65		63		60			57	56			53					49		47	46		44	43	42	40			37	36	35		33					73		31	30	29	28		26	24			21	20			17							16	15	14	13		11	10				5	4	3	2	1	
72		69		67	66	65		63		60			57	56			53																																																																						
		49		47	46		44	43	42	40			37	36	35		33																																																																						
		73		31	30	29	28		26	24			21	20			17																																																																						
				16	15	14	13		11	10				5	4	3	2	1																																																																					
AVAILABLE	NOT APPLICABLE	34566-4133	G	9	B	ST GRAY	<table border="1"> <tr><td></td><td></td><td></td><td>68</td><td>67</td><td></td><td>64</td><td></td><td></td><td></td><td></td><td></td><td>59</td><td>58</td><td></td><td></td><td></td><td></td><td>54</td><td></td></tr> <tr><td></td><td></td><td></td><td></td><td></td><td>46</td><td>45</td><td></td><td></td><td></td><td></td><td></td><td>39</td><td>38</td><td></td><td></td><td></td><td></td><td></td><td></td></tr> <tr><td></td><td></td><td>73</td><td></td><td>32</td><td></td><td>30</td><td>29</td><td>28</td><td>27</td><td></td><td></td><td>23</td><td>22</td><td></td><td></td><td></td><td></td><td></td><td>17</td></tr> <tr><td></td><td></td><td></td><td></td><td>15</td><td></td><td>13</td><td></td><td></td><td>10</td><td>9</td><td>8</td><td></td><td></td><td></td><td></td><td></td><td></td><td></td><td>1</td></tr> </table>				68	67		64						59	58					54							46	45						39	38									73		32		30	29	28	27			23	22						17					15		13			10	9	8								1
			68	67		64						59	58					54																																																																					
					46	45						39	38																																																																										
		73		32		30	29	28	27			23	22						17																																																																				
				15		13			10	9	8								1																																																																				
AVAILABLE	NOT APPLICABLE	34566-4143	G	0	B	ST GRAY	<table border="1"> <tr><td></td><td></td><td></td><td>68</td><td>67</td><td></td><td>64</td><td></td><td></td><td></td><td></td><td></td><td>59</td><td>58</td><td></td><td></td><td></td><td></td><td>54</td><td></td></tr> <tr><td></td><td></td><td></td><td></td><td></td><td>46</td><td>45</td><td></td><td></td><td></td><td></td><td></td><td>39</td><td>38</td><td></td><td></td><td></td><td></td><td></td><td></td></tr> <tr><td></td><td></td><td>73</td><td></td><td>32</td><td></td><td>30</td><td>29</td><td>28</td><td>27</td><td></td><td></td><td>23</td><td>22</td><td></td><td></td><td></td><td></td><td></td><td>17</td></tr> <tr><td></td><td></td><td></td><td></td><td></td><td></td><td></td><td></td><td></td><td>10</td><td>9</td><td></td><td></td><td></td><td></td><td></td><td></td><td></td><td></td><td>1</td></tr> </table>				68	67		64						59	58					54							46	45						39	38									73		32		30	29	28	27			23	22						17										10	9									1
			68	67		64						59	58					54																																																																					
					46	45						39	38																																																																										
		73		32		30	29	28	27			23	22						17																																																																				
									10	9									1																																																																				
AVAILABLE	NOT APPLICABLE	34566-4153	G	0	B	ST GRAY	<table border="1"> <tr><td>72</td><td>70</td><td>68</td><td></td><td>66</td><td></td><td></td><td></td><td></td><td></td><td>60</td><td>59</td><td></td><td></td><td></td><td>55</td><td>54</td><td>53</td><td></td><td></td></tr> <tr><td>52</td><td>50</td><td></td><td>48</td><td>46</td><td></td><td>44</td><td></td><td></td><td></td><td>40</td><td>39</td><td></td><td></td><td></td><td>35</td><td>34</td><td>33</td><td></td><td></td></tr> <tr><td></td><td></td><td>73</td><td></td><td>32</td><td>31</td><td>30</td><td>29</td><td>28</td><td>27</td><td>26</td><td>25</td><td>24</td><td>23</td><td></td><td></td><td>19</td><td>18</td><td></td><td></td></tr> <tr><td></td><td></td><td></td><td></td><td>16</td><td></td><td></td><td></td><td></td><td>10</td><td>9</td><td>8</td><td>7</td><td></td><td></td><td></td><td></td><td></td><td></td><td></td></tr> </table>	72	70	68		66						60	59				55	54	53			52	50		48	46		44				40	39				35	34	33					73		32	31	30	29	28	27	26	25	24	23			19	18							16					10	9	8	7							
72	70	68		66						60	59				55	54	53																																																																						
52	50		48	46		44				40	39				35	34	33																																																																						
		73		32	31	30	29	28	27	26	25	24	23			19	18																																																																						
				16					10	9	8	7																																																																											
AVAILABLE	NOT APPLICABLE	34566-4163	G	0	B	ST GRAY	<table border="1"> <tr><td>72</td><td>70</td><td>68</td><td></td><td>66</td><td></td><td></td><td></td><td></td><td></td><td>60</td><td>59</td><td></td><td></td><td></td><td>55</td><td>54</td><td>53</td><td></td><td></td></tr> <tr><td>52</td><td>50</td><td></td><td>48</td><td>46</td><td></td><td>44</td><td></td><td></td><td></td><td>40</td><td>39</td><td></td><td></td><td></td><td>35</td><td>34</td><td>33</td><td></td><td></td></tr> <tr><td></td><td></td><td>73</td><td></td><td>32</td><td>31</td><td>30</td><td>29</td><td>28</td><td>27</td><td>26</td><td>25</td><td>24</td><td>23</td><td></td><td></td><td>19</td><td>18</td><td></td><td></td></tr> <tr><td></td><td></td><td></td><td></td><td>16</td><td></td><td></td><td></td><td></td><td>10</td><td>9</td><td>8</td><td>7</td><td></td><td></td><td></td><td></td><td></td><td></td><td>1</td></tr> </table>	72	70	68		66						60	59				55	54	53			52	50		48	46		44				40	39				35	34	33					73		32	31	30	29	28	27	26	25	24	23			19	18							16					10	9	8	7							1
72	70	68		66						60	59				55	54	53																																																																						
52	50		48	46		44				40	39				35	34	33																																																																						
		73		32	31	30	29	28	27	26	25	24	23			19	18																																																																						
				16					10	9	8	7							1																																																																				
AVAILABLE	NOT APPLICABLE	34566-4173	G	0	A	BLACK	<table border="1"> <tr><td>72</td><td>71</td><td>70</td><td>69</td><td></td><td></td><td></td><td>64</td><td>63</td><td></td><td></td><td>60</td><td>59</td><td>58</td><td></td><td>56</td><td>55</td><td>54</td><td>53</td><td></td></tr> <tr><td>52</td><td>51</td><td></td><td>49</td><td></td><td>47</td><td></td><td>45</td><td>44</td><td>43</td><td>42</td><td>41</td><td></td><td></td><td>38</td><td></td><td>36</td><td></td><td>34</td><td></td></tr> <tr><td></td><td></td><td>73</td><td></td><td>32</td><td></td><td>30</td><td></td><td>28</td><td></td><td>26</td><td>25</td><td></td><td></td><td></td><td>21</td><td></td><td>19</td><td>18</td><td></td></tr> <tr><td></td><td></td><td></td><td></td><td>16</td><td></td><td>15</td><td></td><td>12</td><td></td><td>10</td><td>9</td><td>8</td><td></td><td></td><td>5</td><td></td><td>3</td><td></td><td></td></tr> </table>	72	71	70	69				64	63			60	59	58		56	55	54	53		52	51		49		47		45	44	43	42	41			38		36		34				73		32		30		28		26	25				21		19	18						16		15		12		10	9	8			5		3		
72	71	70	69				64	63			60	59	58		56	55	54	53																																																																					
52	51		49		47		45	44	43	42	41			38		36		34																																																																					
		73		32		30		28		26	25				21		19	18																																																																					
				16		15		12		10	9	8			5		3																																																																						

ENTER DESCRIPTION IEC NO: UAU2014-0574 DRAWN BY: SKRAJENDRANA 2013/10/08 CHKD: CHYD APPR: IKOSHY 2013/10/09 GO	QUALITY SYMBOLS ∇=0 ∇=0 ∇=0	GENERAL TOLERANCES (UNLESS SPECIFIED) mm INCH 4 PLACES ±--- ±--- 3 PLACES ±--- ±--- 2 PLACES ±--- ±--- 1 PLACE ±--- ±--- 0 PLACE ±--- ±--- ANGULAR ±---° DRAFT WHERE APPLICABLE MUST REMAIN WITHIN DIMENSIONS	DIMENSION STYLE MM ONLY	SCALE DESIGN UNITS METRIC	THIRD ANGLE PROJECTION
	DRAWN BY: SKRAJENDRANA 2011/02/14 CHECKED BY: MYANSLAMBROU 2011/02/14 APPROVED BY:		TITLE MX123 66/73/80CKT HRNS CONN ASSY		SHEET NO. 48 OF 68
	MATERIAL NO. SEE BOM TABLE		DOCUMENT NO. SD-34566-001		SIZE D
	THIS DRAWING CONTAINS INFORMATION THAT IS PROPRIETARY TO MOLEX INCORPORATED AND SHOULD NOT BE USED WITHOUT WRITTEN PERMISSION				

STATUS	GM PART #	MATERIAL #	PART/MATERIAL REVISION	WIRE DRESS OPTION	KEY OPTION	COLOR (TPA)	NUMBERS INDICATE CAVITIES OPEN FOR CIRCUITS																																																																				
AVAILABLE	NOT APPLICABLE	34566-4183	G	0	C	BLUE	<table border="1"> <tr><td>72</td><td>70</td><td>68</td><td>66</td><td>63</td><td>62</td><td>59</td><td>58</td><td>57</td><td></td><td>53</td></tr> <tr><td>52</td><td>51</td><td>48</td><td>47</td><td>46</td><td>44</td><td>42</td><td>40</td><td>39</td><td></td><td>34</td><td>33</td></tr> <tr><td></td><td></td><td>32</td><td>30</td><td></td><td></td><td>26</td><td>25</td><td>23</td><td>22</td><td>21</td><td>20</td><td>17</td></tr> <tr><td>73</td><td></td><td>15</td><td>14</td><td>13</td><td></td><td>10</td><td>9</td><td>7</td><td>6</td><td>5</td><td>4</td><td>1</td></tr> </table>	72	70	68	66	63	62	59	58	57		53	52	51	48	47	46	44	42	40	39		34	33			32	30			26	25	23	22	21	20	17	73		15	14	13		10	9	7	6	5	4	1																			
72	70	68	66	63	62	59	58	57		53																																																																	
52	51	48	47	46	44	42	40	39		34	33																																																																
		32	30			26	25	23	22	21	20	17																																																															
73		15	14	13		10	9	7	6	5	4	1																																																															
AVAILABLE	NOT APPLICABLE	34566-4193	G	0	C	BLUE	<table border="1"> <tr><td>71</td><td>69</td><td></td><td></td><td>65</td><td>64</td><td></td><td>61</td><td>60</td><td>58</td><td>56</td><td>55</td><td>54</td></tr> <tr><td></td><td>50</td><td>49</td><td></td><td>45</td><td>43</td><td></td><td>41</td><td></td><td>38</td><td>37</td><td>36</td><td>35</td></tr> <tr><td></td><td></td><td></td><td>31</td><td>29</td><td>28</td><td></td><td></td><td>24</td><td>23</td><td></td><td>20</td><td>19</td><td>18</td><td>17</td></tr> <tr><td>73</td><td></td><td>16</td><td></td><td>13</td><td>12</td><td>11</td><td></td><td>8</td><td>7</td><td></td><td></td><td>3</td><td>2</td><td>1</td></tr> </table>	71	69			65	64		61	60	58	56	55	54		50	49		45	43		41		38	37	36	35				31	29	28			24	23		20	19	18	17	73		16		13	12	11		8	7			3	2	1												
71	69			65	64		61	60	58	56	55	54																																																															
	50	49		45	43		41		38	37	36	35																																																															
			31	29	28			24	23		20	19	18	17																																																													
73		16		13	12	11		8	7			3	2	1																																																													
AVAILABLE	NOT APPLICABLE	34566-4213	G	0	A	BLACK	<table border="1"> <tr><td>72</td><td>71</td><td></td><td>68</td><td>67</td><td>66</td><td>65</td><td>64</td><td></td><td>60</td><td>59</td><td>58</td><td></td><td></td><td></td></tr> <tr><td></td><td>50</td><td></td><td>48</td><td>47</td><td>46</td><td>45</td><td></td><td></td><td>40</td><td>39</td><td>38</td><td></td><td>35</td><td></td></tr> <tr><td></td><td></td><td></td><td>31</td><td>30</td><td></td><td></td><td></td><td>25</td><td>24</td><td></td><td>22</td><td>21</td><td>20</td><td>17</td></tr> <tr><td>73</td><td></td><td></td><td></td><td>14</td><td></td><td></td><td></td><td>9</td><td>7</td><td>6</td><td>5</td><td>4</td><td>2</td><td>1</td></tr> </table>	72	71		68	67	66	65	64		60	59	58					50		48	47	46	45			40	39	38		35					31	30				25	24		22	21	20	17	73				14				9	7	6	5	4	2	1								
72	71		68	67	66	65	64		60	59	58																																																																
	50		48	47	46	45			40	39	38		35																																																														
			31	30				25	24		22	21	20	17																																																													
73				14				9	7	6	5	4	2	1																																																													
AVAILABLE	NOT APPLICABLE	34566-4223	G	0	A	BLACK	<table border="1"> <tr><td>72</td><td>71</td><td></td><td>68</td><td>67</td><td>66</td><td>65</td><td>64</td><td></td><td>60</td><td>59</td><td>58</td><td></td><td></td><td></td></tr> <tr><td></td><td>50</td><td></td><td>48</td><td>47</td><td>46</td><td>45</td><td></td><td></td><td>40</td><td>39</td><td>38</td><td></td><td>35</td><td>33</td></tr> <tr><td></td><td></td><td></td><td>31</td><td>30</td><td></td><td></td><td></td><td>25</td><td>24</td><td>23</td><td>22</td><td>21</td><td>20</td><td>17</td></tr> <tr><td>73</td><td></td><td></td><td></td><td>14</td><td></td><td></td><td></td><td>9</td><td>8</td><td>7</td><td>6</td><td>5</td><td>4</td><td>2</td><td>1</td></tr> </table>	72	71		68	67	66	65	64		60	59	58					50		48	47	46	45			40	39	38		35	33				31	30				25	24	23	22	21	20	17	73				14				9	8	7	6	5	4	2	1							
72	71		68	67	66	65	64		60	59	58																																																																
	50		48	47	46	45			40	39	38		35	33																																																													
			31	30				25	24	23	22	21	20	17																																																													
73				14				9	8	7	6	5	4	2	1																																																												
AVAILABLE	NOT APPLICABLE	34566-4233	G	0	B	ST GRY	<table border="1"> <tr><td></td><td></td><td>69</td><td></td><td>65</td><td>64</td><td>63</td><td></td><td></td><td></td><td></td><td></td><td></td><td></td><td></td></tr> <tr><td></td><td></td><td>49</td><td></td><td>45</td><td>44</td><td>43</td><td></td><td></td><td></td><td></td><td></td><td></td><td></td><td></td></tr> <tr><td></td><td></td><td></td><td></td><td></td><td></td><td></td><td></td><td></td><td>23</td><td>22</td><td>21</td><td>20</td><td>19</td><td>18</td></tr> <tr><td>73</td><td></td><td></td><td></td><td></td><td></td><td>12</td><td>11</td><td>9</td><td>7</td><td>6</td><td>5</td><td>4</td><td>3</td><td></td></tr> </table>			69		65	64	63											49		45	44	43																		23	22	21	20	19	18	73						12	11	9	7	6	5	4	3									
		69		65	64	63																																																																					
		49		45	44	43																																																																					
									23	22	21	20	19	18																																																													
73						12	11	9	7	6	5	4	3																																																														
AVAILABLE	NOT APPLICABLE	34566-4243	G	0	A	BLACK	<table border="1"> <tr><td></td><td>51</td><td>50</td><td></td><td>47</td><td>46</td><td></td><td></td><td>61</td><td></td><td>58</td><td>57</td><td>56</td><td></td><td></td></tr> <tr><td></td><td></td><td></td><td></td><td>31</td><td>30</td><td></td><td></td><td>26</td><td></td><td>22</td><td>21</td><td>20</td><td></td><td></td></tr> <tr><td>73</td><td></td><td></td><td></td><td>15</td><td>14</td><td></td><td></td><td>10</td><td></td><td></td><td></td><td></td><td></td><td></td></tr> </table>		51	50		47	46			61		58	57	56							31	30			26		22	21	20			73				15	14			10																													
	51	50		47	46			61		58	57	56																																																															
				31	30			26		22	21	20																																																															
73				15	14			10																																																																			
AVAILABLE	NOT APPLICABLE	34566-4253	G	0	A	BLACK	<table border="1"> <tr><td></td><td>51</td><td>50</td><td></td><td>47</td><td>46</td><td>45</td><td></td><td></td><td></td><td>38</td><td>37</td><td>36</td><td></td><td></td></tr> <tr><td></td><td></td><td></td><td></td><td>31</td><td>30</td><td></td><td></td><td>26</td><td></td><td>22</td><td>21</td><td>20</td><td></td><td></td></tr> <tr><td>73</td><td></td><td></td><td></td><td>15</td><td>14</td><td></td><td></td><td>10</td><td></td><td></td><td></td><td></td><td></td><td></td></tr> </table>		51	50		47	46	45				38	37	36							31	30			26		22	21	20			73				15	14			10																													
	51	50		47	46	45				38	37	36																																																															
				31	30			26		22	21	20																																																															
73				15	14			10																																																																			
AVAILABLE	NOT APPLICABLE	34566-4263	G	0	B	ST GRY	<table border="1"> <tr><td>72</td><td>71</td><td>70</td><td>69</td><td>68</td><td></td><td>65</td><td>64</td><td>62</td><td>61</td><td>60</td><td></td><td></td><td></td><td>54</td></tr> <tr><td>52</td><td>51</td><td></td><td></td><td>47</td><td>46</td><td>44</td><td>42</td><td>41</td><td>40</td><td></td><td></td><td></td><td></td><td></td></tr> <tr><td></td><td></td><td></td><td>32</td><td>31</td><td>30</td><td>28</td><td>26</td><td>25</td><td>24</td><td></td><td></td><td></td><td>20</td><td>19</td><td>17</td></tr> <tr><td>73</td><td></td><td></td><td></td><td></td><td></td><td>12</td><td>11</td><td>10</td><td>9</td><td></td><td></td><td></td><td></td><td></td><td>2</td><td>1</td></tr> </table>	72	71	70	69	68		65	64	62	61	60				54	52	51			47	46	44	42	41	40									32	31	30	28	26	25	24				20	19	17	73						12	11	10	9						2	1					
72	71	70	69	68		65	64	62	61	60				54																																																													
52	51			47	46	44	42	41	40																																																																		
			32	31	30	28	26	25	24				20	19	17																																																												
73						12	11	10	9						2	1																																																											
AVAILABLE	NOT APPLICABLE	34566-4273	G	0	B	ST GRY	<table border="1"> <tr><td>72</td><td>71</td><td>70</td><td>69</td><td>68</td><td>67</td><td>66</td><td>65</td><td>64</td><td>62</td><td>61</td><td>60</td><td></td><td></td><td></td><td>54</td></tr> <tr><td>52</td><td>51</td><td></td><td></td><td>47</td><td>45</td><td>44</td><td>42</td><td>41</td><td>40</td><td></td><td></td><td></td><td></td><td></td><td></td><td></td></tr> <tr><td></td><td></td><td></td><td>32</td><td>31</td><td>30</td><td>28</td><td>26</td><td>25</td><td>24</td><td></td><td></td><td></td><td></td><td>20</td><td>19</td><td>17</td></tr> <tr><td>73</td><td></td><td></td><td></td><td></td><td></td><td>13</td><td>12</td><td>11</td><td>10</td><td>9</td><td>8</td><td></td><td></td><td></td><td></td><td>2</td><td>1</td></tr> </table>	72	71	70	69	68	67	66	65	64	62	61	60				54	52	51			47	45	44	42	41	40											32	31	30	28	26	25	24					20	19	17	73						13	12	11	10	9	8					2	1
72	71	70	69	68	67	66	65	64	62	61	60				54																																																												
52	51			47	45	44	42	41	40																																																																		
			32	31	30	28	26	25	24					20	19	17																																																											
73						13	12	11	10	9	8					2	1																																																										

ENTER DESCRIPTION EC NO: UAU2014-0574 DRWNS:SKRAJENDRANA 2013/10/08 CHKD: APPR:KOSHY	2013/10/09 DESCRIPTION REV	QUALITY SYMBOLS ∇=0 ∇=0 ∇=0	GENERAL TOLERANCES (UNLESS SPECIFIED) <table border="1"> <tr><th></th><th>mm</th><th>INCH</th></tr> <tr><td>4 PLACES</td><td>±---</td><td>±---</td></tr> <tr><td>3 PLACES</td><td>±---</td><td>±---</td></tr> <tr><td>2 PLACES</td><td>±---</td><td>±---</td></tr> <tr><td>1 PLACE</td><td>±---</td><td>±---</td></tr> <tr><td>0 PLACE</td><td>±---</td><td>±---</td></tr> </table>		mm	INCH	4 PLACES	±---	±---	3 PLACES	±---	±---	2 PLACES	±---	±---	1 PLACE	±---	±---	0 PLACE	±---	±---	DIMENSION STYLE MM ONLY	SCALE METRIC	DESIGN UNITS METRIC	THIRD ANGLE PROJECTION
		mm	INCH																						
	4 PLACES	±---	±---																						
	3 PLACES	±---	±---																						
2 PLACES	±---	±---																							
1 PLACE	±---	±---																							
0 PLACE	±---	±---																							
DRAWN BY: SKRAJENDRANA 2011/02/14 CHECKED BY: MYANSLAMBROU 2011/02/14 APPROVED BY:	DATE:	TITLE:	MX123 66/73/80CKT HRNS CONN ASSY																						
MATERIAL NO.	DOCUMENT NO.	SHEET NO.	49 OF 68																						
SEE BOM TABLE			SD-34566-001																						

THIS DRAWING CONTAINS INFORMATION THAT IS PROPRIETARY TO MOLEX INCORPORATED AND SHOULD NOT BE USED WITHOUT WRITTEN PERMISSION

STATUS	GM PART #	MATERIAL #	PART/MATERIAL REVISION	WIRE DRESS OPTION	KEY OPTION	COLOR (TPA)	NUMBERS INDICATE CAVITIES OPEN FOR CIRCUITS																																																																																			
AVAILABLE	NOT APPLICABLE	34566-4283	G	0	A	BLACK	<table border="1"> <tr><td></td><td>70</td><td>69</td><td></td><td></td><td></td><td></td><td>63</td><td>62</td><td>61</td><td>60</td><td></td><td></td><td>57</td><td>56</td><td>55</td><td>54</td><td>53</td></tr> <tr><td>52</td><td>51</td><td>49</td><td></td><td></td><td></td><td></td><td>44</td><td>43</td><td>42</td><td>41</td><td></td><td></td><td></td><td>37</td><td>36</td><td></td><td>34</td></tr> <tr><td></td><td></td><td></td><td>32</td><td></td><td></td><td></td><td>29</td><td>28</td><td>27</td><td>26</td><td></td><td></td><td>23</td><td></td><td></td><td></td><td>19</td><td>18</td></tr> <tr><td></td><td></td><td></td><td>16</td><td>15</td><td></td><td></td><td>13</td><td>12</td><td>11</td><td>10</td><td></td><td></td><td>8</td><td></td><td></td><td></td><td>3</td><td></td></tr> </table>		70	69					63	62	61	60			57	56	55	54	53	52	51	49					44	43	42	41				37	36		34				32				29	28	27	26			23				19	18				16	15			13	12	11	10			8				3										
	70	69					63	62	61	60			57	56	55	54	53																																																																									
52	51	49					44	43	42	41				37	36		34																																																																									
			32				29	28	27	26			23				19	18																																																																								
			16	15			13	12	11	10			8				3																																																																									
AVAILABLE	NOT APPLICABLE	34566-4293	G	0	B	ST GRAY	<table border="1"> <tr><td></td><td></td><td></td><td></td><td>67</td><td>66</td><td></td><td></td><td>63</td><td></td><td></td><td></td><td></td><td>59</td><td>58</td><td>57</td><td>56</td><td>55</td><td>53</td></tr> <tr><td></td><td></td><td>50</td><td>49</td><td>48</td><td></td><td></td><td>45</td><td>43</td><td></td><td></td><td></td><td></td><td>39</td><td>38</td><td>37</td><td>36</td><td>35</td><td>34</td><td>33</td></tr> <tr><td></td><td></td><td></td><td></td><td></td><td></td><td></td><td>29</td><td>27</td><td></td><td></td><td></td><td></td><td>23</td><td>22</td><td>21</td><td></td><td></td><td>18</td><td></td></tr> <tr><td></td><td></td><td></td><td></td><td></td><td></td><td></td><td>16</td><td>15</td><td>14</td><td>13</td><td></td><td></td><td>8</td><td>7</td><td>6</td><td>5</td><td>4</td><td>3</td><td></td></tr> </table>					67	66			63					59	58	57	56	55	53			50	49	48			45	43					39	38	37	36	35	34	33								29	27					23	22	21			18									16	15	14	13			8	7	6	5	4	3					
				67	66			63					59	58	57	56	55	53																																																																								
		50	49	48			45	43					39	38	37	36	35	34	33																																																																							
							29	27					23	22	21			18																																																																								
							16	15	14	13			8	7	6	5	4	3																																																																								
AVAILABLE	NOT APPLICABLE	34566-4313	G	0	B	ST GRAY	<table border="1"> <tr><td></td><td></td><td></td><td></td><td></td><td></td><td></td><td></td><td>63</td><td></td><td></td><td></td><td></td><td>59</td><td>58</td><td>57</td><td>56</td><td>55</td><td>53</td></tr> <tr><td></td><td></td><td>50</td><td>49</td><td>48</td><td></td><td></td><td>46</td><td>43</td><td></td><td></td><td></td><td></td><td>39</td><td>38</td><td>37</td><td>36</td><td>35</td><td>34</td><td>33</td></tr> <tr><td></td><td></td><td></td><td></td><td></td><td></td><td></td><td>29</td><td>27</td><td></td><td></td><td></td><td></td><td>23</td><td>22</td><td>21</td><td></td><td></td><td>18</td><td></td></tr> <tr><td></td><td></td><td></td><td></td><td></td><td></td><td></td><td>16</td><td>15</td><td>14</td><td>13</td><td></td><td></td><td>7</td><td>6</td><td>5</td><td>4</td><td>3</td><td></td><td></td></tr> </table>									63					59	58	57	56	55	53			50	49	48			46	43					39	38	37	36	35	34	33								29	27					23	22	21			18									16	15	14	13			7	6	5	4	3						
								63					59	58	57	56	55	53																																																																								
		50	49	48			46	43					39	38	37	36	35	34	33																																																																							
							29	27					23	22	21			18																																																																								
							16	15	14	13			7	6	5	4	3																																																																									
AVAILABLE	NOT APPLICABLE	34566-4323	G	0	B	ST GRAY	<table border="1"> <tr><td>72</td><td>70</td><td>68</td><td></td><td>66</td><td></td><td></td><td></td><td></td><td></td><td>60</td><td>59</td><td></td><td></td><td></td><td></td><td>55</td><td>54</td><td>53</td></tr> <tr><td>52</td><td>51</td><td>48</td><td></td><td>46</td><td></td><td></td><td></td><td></td><td></td><td>40</td><td>39</td><td></td><td></td><td></td><td></td><td>35</td><td>34</td><td>33</td></tr> <tr><td></td><td></td><td></td><td>32</td><td>31</td><td>30</td><td>29</td><td>28</td><td>27</td><td>26</td><td>25</td><td>24</td><td></td><td></td><td></td><td></td><td>19</td><td>18</td><td>17</td></tr> <tr><td></td><td></td><td></td><td>16</td><td></td><td></td><td></td><td></td><td></td><td>10</td><td>8</td><td>7</td><td></td><td></td><td></td><td></td><td></td><td></td><td>2</td><td>1</td></tr> </table>	72	70	68		66						60	59					55	54	53	52	51	48		46						40	39					35	34	33				32	31	30	29	28	27	26	25	24					19	18	17				16						10	8	7							2	1						
72	70	68		66						60	59					55	54	53																																																																								
52	51	48		46						40	39					35	34	33																																																																								
			32	31	30	29	28	27	26	25	24					19	18	17																																																																								
			16						10	8	7							2	1																																																																							
AVAILABLE	NOT APPLICABLE	34566-4333	G	0	A	BLACK	<table border="1"> <tr><td>72</td><td>71</td><td>70</td><td>69</td><td></td><td>67</td><td></td><td></td><td>64</td><td>63</td><td></td><td></td><td>60</td><td>59</td><td></td><td></td><td>56</td><td>55</td><td>54</td><td>53</td></tr> <tr><td>52</td><td>51</td><td>49</td><td></td><td></td><td>47</td><td></td><td></td><td>45</td><td>44</td><td>43</td><td>42</td><td>41</td><td></td><td></td><td>38</td><td></td><td>36</td><td></td><td>34</td></tr> <tr><td></td><td></td><td></td><td></td><td></td><td>32</td><td></td><td>30</td><td></td><td>28</td><td>26</td><td>25</td><td></td><td>23</td><td></td><td></td><td></td><td></td><td>19</td><td>18</td></tr> <tr><td></td><td></td><td></td><td></td><td></td><td>16</td><td>15</td><td></td><td></td><td>12</td><td>10</td><td>9</td><td></td><td></td><td></td><td></td><td></td><td></td><td>3</td><td></td></tr> </table>	72	71	70	69		67			64	63			60	59			56	55	54	53	52	51	49			47			45	44	43	42	41			38		36		34						32		30		28	26	25		23					19	18						16	15			12	10	9							3				
72	71	70	69		67			64	63			60	59			56	55	54	53																																																																							
52	51	49			47			45	44	43	42	41			38		36		34																																																																							
					32		30		28	26	25		23					19	18																																																																							
					16	15			12	10	9							3																																																																								
AVAILABLE	NOT APPLICABLE	34566-4343	G	0	A	BLACK	<table border="1"> <tr><td>72</td><td>71</td><td>70</td><td>69</td><td></td><td></td><td></td><td></td><td>64</td><td>63</td><td></td><td></td><td>60</td><td>59</td><td>58</td><td></td><td>56</td><td>55</td><td>54</td><td>53</td></tr> <tr><td>52</td><td>51</td><td>49</td><td></td><td></td><td>47</td><td></td><td></td><td>45</td><td>44</td><td>43</td><td>42</td><td>41</td><td></td><td></td><td>38</td><td></td><td>36</td><td></td><td>34</td></tr> <tr><td></td><td></td><td></td><td></td><td></td><td>32</td><td></td><td>30</td><td></td><td>28</td><td>26</td><td>25</td><td></td><td></td><td></td><td></td><td></td><td></td><td>19</td><td>18</td></tr> <tr><td></td><td></td><td></td><td></td><td></td><td>16</td><td>15</td><td></td><td></td><td>12</td><td>10</td><td>9</td><td></td><td></td><td></td><td></td><td></td><td></td><td>3</td><td></td></tr> </table>	72	71	70	69					64	63			60	59	58		56	55	54	53	52	51	49			47			45	44	43	42	41			38		36		34						32		30		28	26	25							19	18						16	15			12	10	9							3				
72	71	70	69					64	63			60	59	58		56	55	54	53																																																																							
52	51	49			47			45	44	43	42	41			38		36		34																																																																							
					32		30		28	26	25							19	18																																																																							
					16	15			12	10	9							3																																																																								
AVAILABLE	NOT APPLICABLE	34566-4353	G	0	C	BLUE	<table border="1"> <tr><td>72</td><td>70</td><td>68</td><td></td><td></td><td></td><td></td><td></td><td>63</td><td>62</td><td></td><td></td><td>59</td><td>58</td><td>57</td><td></td><td></td><td></td><td></td><td>53</td></tr> <tr><td>52</td><td>51</td><td></td><td>48</td><td>47</td><td></td><td></td><td>44</td><td>42</td><td>40</td><td>39</td><td></td><td></td><td></td><td></td><td></td><td></td><td></td><td></td><td>34</td><td>33</td></tr> <tr><td></td><td></td><td></td><td>32</td><td></td><td>30</td><td></td><td></td><td>26</td><td>25</td><td>23</td><td>22</td><td>21</td><td>20</td><td></td><td></td><td></td><td></td><td></td><td>17</td><td></td></tr> <tr><td></td><td></td><td></td><td></td><td></td><td>15</td><td>14</td><td>13</td><td></td><td></td><td>7</td><td>6</td><td>5</td><td>4</td><td></td><td></td><td></td><td></td><td></td><td>1</td><td></td></tr> </table>	72	70	68						63	62			59	58	57					53	52	51		48	47			44	42	40	39									34	33				32		30			26	25	23	22	21	20						17							15	14	13			7	6	5	4						1	
72	70	68						63	62			59	58	57					53																																																																							
52	51		48	47			44	42	40	39									34	33																																																																						
			32		30			26	25	23	22	21	20						17																																																																							
					15	14	13			7	6	5	4						1																																																																							
AVAILABLE	NOT APPLICABLE	34566-4363	G	0	A	BLACK	<table border="1"> <tr><td></td><td>70</td><td>69</td><td></td><td></td><td></td><td></td><td></td><td>63</td><td>62</td><td>61</td><td>60</td><td></td><td></td><td>58</td><td>57</td><td>56</td><td>55</td><td>54</td><td>53</td></tr> <tr><td>52</td><td>51</td><td>49</td><td></td><td></td><td></td><td></td><td></td><td>44</td><td>43</td><td>42</td><td>41</td><td></td><td></td><td></td><td>37</td><td>36</td><td></td><td>34</td><td></td></tr> <tr><td></td><td></td><td></td><td></td><td></td><td></td><td></td><td></td><td>29</td><td>28</td><td>27</td><td>26</td><td></td><td></td><td>23</td><td></td><td></td><td></td><td></td><td>19</td><td>18</td></tr> <tr><td></td><td></td><td></td><td></td><td></td><td></td><td></td><td></td><td>16</td><td>15</td><td>13</td><td>12</td><td>11</td><td>10</td><td>8</td><td></td><td></td><td></td><td></td><td>3</td><td></td></tr> </table>		70	69						63	62	61	60			58	57	56	55	54	53	52	51	49						44	43	42	41				37	36		34										29	28	27	26			23					19	18									16	15	13	12	11	10	8					3		
	70	69						63	62	61	60			58	57	56	55	54	53																																																																							
52	51	49						44	43	42	41				37	36		34																																																																								
								29	28	27	26			23					19	18																																																																						
								16	15	13	12	11	10	8					3																																																																							
AVAILABLE	NOT APPLICABLE	34566-4373	G	0	A	BLACK	<table border="1"> <tr><td></td><td>70</td><td>69</td><td></td><td></td><td></td><td></td><td></td><td>63</td><td></td><td></td><td></td><td></td><td></td><td>58</td><td></td><td>56</td><td></td><td>54</td><td></td></tr> <tr><td>52</td><td>51</td><td>49</td><td></td><td></td><td></td><td></td><td></td><td>44</td><td>43</td><td>42</td><td>41</td><td>40</td><td></td><td></td><td></td><td></td><td></td><td>36</td><td>34</td></tr> <tr><td></td><td></td><td></td><td></td><td></td><td></td><td></td><td></td><td>28</td><td>26</td><td></td><td></td><td></td><td></td><td></td><td></td><td></td><td></td><td></td><td>19</td><td>18</td></tr> <tr><td></td><td></td><td></td><td></td><td></td><td></td><td></td><td></td><td>16</td><td></td><td>12</td><td>10</td><td></td><td></td><td></td><td></td><td></td><td></td><td></td><td>3</td><td>2</td><td>1</td></tr> </table>		70	69						63						58		56		54		52	51	49						44	43	42	41	40						36	34									28	26										19	18									16		12	10								3	2	1
	70	69						63						58		56		54																																																																								
52	51	49						44	43	42	41	40						36	34																																																																							
								28	26										19	18																																																																						
								16		12	10								3	2	1																																																																					

ENTER DESCRIPTION IEC NO: UAU2014-0574 DRAWN BY: SKRAJENDRANA 2013/10/08 CHKD: GO APPR: IKOSHY 2013/10/09	QUALITY SYMBOLS ∇=0 ∇=0 ∇=0	GENERAL TOLERANCES (UNLESS SPECIFIED) mm INCH 4 PLACES ± --- ± --- 3 PLACES ± --- ± --- 2 PLACES ± --- ± --- 1 PLACE ± --- ± --- 0 PLACE ± --- ± --- ANGULAR ± --- ° DRAFT WHERE APPLICABLE MUST REMAIN WITHIN DIMENSIONS	DIMENSION STYLE MM ONLY	SCALE DESIGN UNITS METRIC	THIRD ANGLE PROJECTION
	DRAWN BY: SKRAJENDRANA 2011/02/14 CHECKED BY: MVANSLAMBROU 2011/02/14 APPROVED BY:		TITLE MX123 66/73/80CKT HRNS CONN ASSY		MATERIAL NO. SD-34566-001
	SEE BOM TABLE		DOCUMENT NO.		SHEET NO. 50 OF 68
	THIS DRAWING CONTAINS INFORMATION THAT IS PROPRIETARY TO MOLEX INCORPORATED AND SHOULD NOT BE USED WITHOUT WRITTEN PERMISSION				

STATUS	GM PART #	MATERIAL #	PART/MATERIAL REVISION	WIRE DRESS OPTION	KEY OPTION	COLOR (TPA)	NUMBERS INDICATE CAVITIES OPEN FOR CIRCUITS																																																																									
AVAILABLE	NOT APPLICABLE	34566-4483	G	9	C	BLUE	<table border="1"> <tr><td>72</td><td>70</td><td>68</td><td>67</td><td>66</td><td></td><td>63</td><td>62</td><td></td><td>59</td><td>58</td><td>57</td><td>56</td><td>55</td><td>53</td></tr> <tr><td>52</td><td>51</td><td>49</td><td>48</td><td>47</td><td>46</td><td>44</td><td></td><td></td><td>40</td><td>39</td><td>38</td><td>37</td><td>36</td><td>34</td><td>33</td></tr> <tr><td colspan="2">73</td><td>32</td><td>30</td><td></td><td></td><td>27</td><td>26</td><td>25</td><td>24</td><td>23</td><td>22</td><td>21</td><td>20</td><td>19</td><td>18</td><td>17</td></tr> <tr><td></td><td></td><td>15</td><td>14</td><td>13</td><td></td><td></td><td>10</td><td>9</td><td>8</td><td>7</td><td>6</td><td>5</td><td>4</td><td>3</td><td>2</td><td>1</td></tr> </table>	72	70	68	67	66		63	62		59	58	57	56	55	53	52	51	49	48	47	46	44			40	39	38	37	36	34	33	73		32	30			27	26	25	24	23	22	21	20	19	18	17			15	14	13			10	9	8	7	6	5	4	3	2	1								
72	70	68	67	66		63	62		59	58	57	56	55	53																																																																		
52	51	49	48	47	46	44			40	39	38	37	36	34	33																																																																	
73		32	30			27	26	25	24	23	22	21	20	19	18	17																																																																
		15	14	13			10	9	8	7	6	5	4	3	2	1																																																																
AVAILABLE	NOT APPLICABLE	34566-4493	G	9	A	BLACK	<table border="1"> <tr><td>72</td><td>71</td><td>70</td><td>69</td><td>67</td><td></td><td>64</td><td>63</td><td>62</td><td>61</td><td>60</td><td>59</td><td>58</td><td>57</td><td>56</td><td>55</td><td>54</td><td>53</td></tr> <tr><td>52</td><td>51</td><td>50</td><td>49</td><td>48</td><td>47</td><td>45</td><td>44</td><td>43</td><td>42</td><td>41</td><td>40</td><td>39</td><td>38</td><td>37</td><td>36</td><td>34</td><td>33</td></tr> <tr><td colspan="2">73</td><td>32</td><td>30</td><td>29</td><td>28</td><td>27</td><td>26</td><td></td><td>24</td><td>23</td><td></td><td>21</td><td></td><td>19</td><td>18</td><td>17</td></tr> <tr><td></td><td></td><td>16</td><td>15</td><td>14</td><td>13</td><td>12</td><td>11</td><td>10</td><td></td><td>8</td><td></td><td>5</td><td></td><td>3</td><td>2</td><td>1</td></tr> </table>	72	71	70	69	67		64	63	62	61	60	59	58	57	56	55	54	53	52	51	50	49	48	47	45	44	43	42	41	40	39	38	37	36	34	33	73		32	30	29	28	27	26		24	23		21		19	18	17			16	15	14	13	12	11	10		8		5		3	2	1			
72	71	70	69	67		64	63	62	61	60	59	58	57	56	55	54	53																																																															
52	51	50	49	48	47	45	44	43	42	41	40	39	38	37	36	34	33																																																															
73		32	30	29	28	27	26		24	23		21		19	18	17																																																																
		16	15	14	13	12	11	10		8		5		3	2	1																																																																
AVAILABLE	NOT APPLICABLE	34566-4513	G	9	B	ST GRY	<table border="1"> <tr><td>72</td><td>71</td><td>70</td><td>68</td><td>67</td><td>66</td><td></td><td></td><td>62</td><td>61</td><td>60</td><td>59</td><td>58</td><td>57</td><td>56</td><td>55</td><td>54</td><td>53</td></tr> <tr><td>52</td><td>51</td><td>50</td><td>48</td><td>47</td><td>46</td><td></td><td></td><td>42</td><td>41</td><td>40</td><td>39</td><td>38</td><td>37</td><td>36</td><td>35</td><td>34</td><td>33</td></tr> <tr><td colspan="2">73</td><td>32</td><td>31</td><td>30</td><td>29</td><td>28</td><td>27</td><td>26</td><td>25</td><td>24</td><td>23</td><td></td><td></td><td>19</td><td>18</td><td>17</td></tr> <tr><td></td><td></td><td>16</td><td>15</td><td>14</td><td>13</td><td></td><td></td><td>10</td><td></td><td>8</td><td>7</td><td></td><td></td><td>3</td><td>2</td><td>1</td></tr> </table>	72	71	70	68	67	66			62	61	60	59	58	57	56	55	54	53	52	51	50	48	47	46			42	41	40	39	38	37	36	35	34	33	73		32	31	30	29	28	27	26	25	24	23			19	18	17			16	15	14	13			10		8	7			3	2	1			
72	71	70	68	67	66			62	61	60	59	58	57	56	55	54	53																																																															
52	51	50	48	47	46			42	41	40	39	38	37	36	35	34	33																																																															
73		32	31	30	29	28	27	26	25	24	23			19	18	17																																																																
		16	15	14	13			10		8	7			3	2	1																																																																
AVAILABLE	NOT APPLICABLE	34566-4523	G	0	G	BLUE	<table border="1"> <tr><td></td><td>78</td><td>77</td><td>75</td><td>74</td><td>72</td><td>70</td><td>69</td><td>67</td><td>66</td><td>65</td><td>64</td><td>63</td><td>62</td><td></td><td></td><td></td><td></td></tr> <tr><td>60</td><td>58</td><td>57</td><td>55</td><td>54</td><td>52</td><td>51</td><td>50</td><td>49</td><td>47</td><td>45</td><td></td><td></td><td></td><td></td><td></td><td></td><td></td></tr> <tr><td>40</td><td>38</td><td>37</td><td></td><td></td><td></td><td>31</td><td></td><td></td><td>27</td><td>26</td><td>25</td><td>24</td><td></td><td></td><td></td><td></td><td></td></tr> <tr><td>20</td><td>18</td><td>17</td><td></td><td></td><td></td><td></td><td>10</td><td>9</td><td>8</td><td>6</td><td>5</td><td></td><td></td><td>3</td><td>2</td><td>1</td><td></td></tr> </table>		78	77	75	74	72	70	69	67	66	65	64	63	62					60	58	57	55	54	52	51	50	49	47	45								40	38	37				31			27	26	25	24						20	18	17					10	9	8	6	5			3	2	1		
	78	77	75	74	72	70	69	67	66	65	64	63	62																																																																			
60	58	57	55	54	52	51	50	49	47	45																																																																						
40	38	37				31			27	26	25	24																																																																				
20	18	17					10	9	8	6	5			3	2	1																																																																
AVAILABLE	NOT APPLICABLE	34566-4533	G	0	A	BLACK	<table border="1"> <tr><td>72</td><td></td><td>69</td><td>67</td><td>65</td><td>63</td><td></td><td></td><td>60</td><td></td><td>57</td><td>56</td><td></td><td></td><td></td><td></td><td></td><td>53</td></tr> <tr><td></td><td></td><td>49</td><td>47</td><td>44</td><td>43</td><td></td><td></td><td>40</td><td></td><td>37</td><td>36</td><td>35</td><td></td><td></td><td></td><td></td><td>33</td></tr> <tr><td colspan="2">73</td><td></td><td>31</td><td>30</td><td>29</td><td>28</td><td></td><td>24</td><td></td><td>21</td><td>20</td><td></td><td></td><td></td><td></td><td></td><td>17</td></tr> <tr><td></td><td></td><td>16</td><td>15</td><td>14</td><td>13</td><td>11</td><td>10</td><td></td><td></td><td></td><td></td><td></td><td></td><td>5</td><td>4</td><td>3</td><td>2</td><td>1</td></tr> </table>	72		69	67	65	63			60		57	56						53			49	47	44	43			40		37	36	35					33	73			31	30	29	28		24		21	20						17			16	15	14	13	11	10							5	4	3	2	1
72		69	67	65	63			60		57	56						53																																																															
		49	47	44	43			40		37	36	35					33																																																															
73			31	30	29	28		24		21	20						17																																																															
		16	15	14	13	11	10							5	4	3	2	1																																																														
AVAILABLE	NOT APPLICABLE	34566-4543	G	0	B	ST GRY	<table border="1"> <tr><td></td><td></td><td></td><td>68</td><td>67</td><td></td><td>64</td><td>63</td><td></td><td></td><td></td><td>58</td><td>57</td><td></td><td>55</td><td>53</td><td></td><td></td></tr> <tr><td></td><td></td><td></td><td>46</td><td>45</td><td>43</td><td></td><td></td><td></td><td></td><td></td><td>38</td><td>37</td><td></td><td>35</td><td></td><td></td><td></td></tr> <tr><td colspan="2">73</td><td></td><td>32</td><td>30</td><td>29</td><td>28</td><td>27</td><td></td><td></td><td></td><td>22</td><td>21</td><td></td><td>19</td><td>17</td><td></td><td></td></tr> <tr><td></td><td></td><td></td><td></td><td></td><td></td><td>12</td><td>10</td><td></td><td></td><td></td><td></td><td></td><td></td><td></td><td></td><td></td><td>1</td></tr> </table>				68	67		64	63				58	57		55	53						46	45	43						38	37		35				73			32	30	29	28	27				22	21		19	17									12	10										1	
			68	67		64	63				58	57		55	53																																																																	
			46	45	43						38	37		35																																																																		
73			32	30	29	28	27				22	21		19	17																																																																	
						12	10										1																																																															
AVAILABLE	NOT APPLICABLE	34566-4553	G	0	B	ST GRY	<table border="1"> <tr><td></td><td></td><td></td><td>68</td><td>67</td><td></td><td>64</td><td>63</td><td></td><td></td><td></td><td>58</td><td>57</td><td></td><td>55</td><td>53</td><td></td><td></td></tr> <tr><td></td><td></td><td></td><td>46</td><td>45</td><td>43</td><td></td><td></td><td></td><td></td><td></td><td>38</td><td>37</td><td></td><td>35</td><td></td><td></td><td></td></tr> <tr><td colspan="2">73</td><td></td><td>32</td><td>30</td><td>29</td><td>28</td><td>27</td><td></td><td></td><td></td><td>22</td><td>21</td><td></td><td>19</td><td>17</td><td></td><td></td></tr> <tr><td></td><td></td><td></td><td></td><td></td><td></td><td>12</td><td>10</td><td></td><td></td><td></td><td></td><td></td><td></td><td></td><td></td><td></td><td>1</td></tr> </table>				68	67		64	63				58	57		55	53						46	45	43						38	37		35				73			32	30	29	28	27				22	21		19	17									12	10										1	
			68	67		64	63				58	57		55	53																																																																	
			46	45	43						38	37		35																																																																		
73			32	30	29	28	27				22	21		19	17																																																																	
						12	10										1																																																															
AVAILABLE	NOT APPLICABLE	34566-4563	G	0	B	ST GRY	<table border="1"> <tr><td></td><td></td><td></td><td>68</td><td>67</td><td></td><td>64</td><td>63</td><td></td><td></td><td></td><td>58</td><td></td><td></td><td>55</td><td>53</td><td></td><td></td></tr> <tr><td></td><td></td><td></td><td>46</td><td>45</td><td>43</td><td></td><td></td><td></td><td></td><td></td><td>38</td><td></td><td></td><td>35</td><td></td><td></td><td></td></tr> <tr><td colspan="2">73</td><td></td><td>32</td><td>30</td><td>29</td><td>28</td><td>27</td><td></td><td></td><td></td><td>22</td><td></td><td></td><td>19</td><td>17</td><td></td><td></td></tr> <tr><td></td><td></td><td></td><td></td><td></td><td></td><td>12</td><td>10</td><td></td><td></td><td></td><td></td><td></td><td></td><td></td><td></td><td></td><td>1</td></tr> </table>				68	67		64	63				58			55	53						46	45	43						38			35				73			32	30	29	28	27				22			19	17									12	10										1	
			68	67		64	63				58			55	53																																																																	
			46	45	43						38			35																																																																		
73			32	30	29	28	27				22			19	17																																																																	
						12	10										1																																																															
AVAILABLE	NOT APPLICABLE	34566-4573	G	0	B	ST GRY	<table border="1"> <tr><td></td><td></td><td></td><td>68</td><td>67</td><td></td><td>64</td><td>63</td><td></td><td></td><td></td><td>58</td><td></td><td></td><td>55</td><td>53</td><td></td><td></td></tr> <tr><td></td><td></td><td></td><td>46</td><td>45</td><td>43</td><td></td><td></td><td></td><td></td><td></td><td>38</td><td></td><td></td><td>35</td><td></td><td></td><td></td></tr> <tr><td colspan="2">73</td><td></td><td>32</td><td>30</td><td>29</td><td>28</td><td>27</td><td></td><td></td><td></td><td>22</td><td></td><td></td><td>19</td><td>17</td><td></td><td></td></tr> <tr><td></td><td></td><td></td><td></td><td></td><td></td><td>12</td><td>10</td><td></td><td></td><td></td><td></td><td></td><td></td><td></td><td></td><td></td><td>1</td></tr> </table>				68	67		64	63				58			55	53						46	45	43						38			35				73			32	30	29	28	27				22			19	17									12	10										1	
			68	67		64	63				58			55	53																																																																	
			46	45	43						38			35																																																																		
73			32	30	29	28	27				22			19	17																																																																	
						12	10										1																																																															

ENTER DESCRIPTION IEC NO: UAU2014-0574 DRAWN BY: SKRAJENDRANA 2011/02/14 CHKD: GO APPR: IKOSHY 2013/10/09	QUALITY SYMBOLS	GENERAL TOLERANCES (UNLESS SPECIFIED)	DIMENSION STYLE	SCALE	DESIGN UNITS	THIRD ANGLE PROJECTION	
	∇=0 ∇=0 ∇=0	4 PLACES ±---+--- 3 PLACES ±---+--- 2 PLACES ±---+--- 1 PLACE ±---+--- 0 PLACE ±---+---	mm INCH ANGULAR ±---° DRAFT WHERE APPLICABLE MUST REMAIN WITHIN DIMENSIONS	MM ONLY DRAWN BY: SKRAJENDRANA 2011/02/14 CHECKED BY: MYANSLAMBROU 2011/02/14 APPROVED BY:	DATE	METRIC	MX123 66/73/80CKT HRNS CONN ASSY molex SD-34566-001
	MATERIAL NO.	DOCUMENT NO.	SHEET NO.				
	SEE BOM TABLE	52 OF 68	THIS DRAWING CONTAINS INFORMATION THAT IS PROPRIETARY TO MOLEX INCORPORATED AND SHOULD NOT BE USED WITHOUT WRITTEN PERMISSION				

STATUS	GM PART #	MATERIAL #	PART/MATERIAL REVISION	WIRE DRESS OPTION	KEY OPTION	COLOR (TPA)	NUMBERS INDICATE CAVITIES OPEN FOR CIRCUITS																																																																																	
AVAILABLE	NOT APPLICABLE	34566-4683	G	9	B	ST GRAY	<table border="1"> <tr><td>72</td><td>71</td><td>70</td><td>69</td><td>68</td><td>67</td><td>66</td><td>65</td><td>64</td><td></td><td>62</td><td>61</td><td>60</td><td>59</td><td>58</td><td>57</td><td>56</td><td>55</td><td>54</td></tr> <tr><td>52</td><td>51</td><td>50</td><td>49</td><td></td><td></td><td>46</td><td>44</td><td></td><td></td><td>41</td><td>40</td><td></td><td>38</td><td>37</td><td>36</td><td></td><td></td><td></td></tr> <tr><td></td><td></td><td></td><td></td><td>73</td><td></td><td>32</td><td>31</td><td>30</td><td>29</td><td>28</td><td>27</td><td>25</td><td>24</td><td></td><td>21</td><td>20</td><td></td><td>18</td><td>17</td></tr> <tr><td></td><td></td><td></td><td></td><td></td><td></td><td>16</td><td>15</td><td>14</td><td>13</td><td>12</td><td></td><td>10</td><td>9</td><td>8</td><td>7</td><td>6</td><td>5</td><td>4</td><td>3</td><td>2</td></tr> </table>	72	71	70	69	68	67	66	65	64		62	61	60	59	58	57	56	55	54	52	51	50	49			46	44			41	40		38	37	36								73		32	31	30	29	28	27	25	24		21	20		18	17							16	15	14	13	12		10	9	8	7	6	5	4	3	2		
72	71	70	69	68	67	66	65	64		62	61	60	59	58	57	56	55	54																																																																						
52	51	50	49			46	44			41	40		38	37	36																																																																									
				73		32	31	30	29	28	27	25	24		21	20		18	17																																																																					
						16	15	14	13	12		10	9	8	7	6	5	4	3	2																																																																				
AVAILABLE	NOT APPLICABLE	34566-4693	G	0	B	ST GRAY	<table border="1"> <tr><td>72</td><td>71</td><td>70</td><td>69</td><td>68</td><td>67</td><td>66</td><td>65</td><td></td><td></td><td>61</td><td>60</td><td></td><td></td><td>57</td><td>56</td><td>55</td><td>54</td><td></td><td></td></tr> <tr><td>52</td><td>51</td><td>50</td><td>49</td><td>48</td><td></td><td>46</td><td>44</td><td></td><td></td><td>41</td><td>40</td><td></td><td>38</td><td>37</td><td>36</td><td></td><td></td><td></td><td></td></tr> <tr><td></td><td></td><td></td><td></td><td>73</td><td></td><td>32</td><td>31</td><td>30</td><td>29</td><td>28</td><td>27</td><td></td><td>24</td><td></td><td>21</td><td>20</td><td>19</td><td>18</td><td>17</td></tr> <tr><td></td><td></td><td></td><td></td><td></td><td></td><td>16</td><td>15</td><td>14</td><td>13</td><td>12</td><td>11</td><td>10</td><td>9</td><td>8</td><td>7</td><td>6</td><td>5</td><td>4</td><td>3</td><td>2</td></tr> </table>	72	71	70	69	68	67	66	65			61	60			57	56	55	54			52	51	50	49	48		46	44			41	40		38	37	36									73		32	31	30	29	28	27		24		21	20	19	18	17							16	15	14	13	12	11	10	9	8	7	6	5	4	3	2
72	71	70	69	68	67	66	65			61	60			57	56	55	54																																																																							
52	51	50	49	48		46	44			41	40		38	37	36																																																																									
				73		32	31	30	29	28	27		24		21	20	19	18	17																																																																					
						16	15	14	13	12	11	10	9	8	7	6	5	4	3	2																																																																				
AVAILABLE	NOT APPLICABLE	34566-4713	G	0	A	BLACK	<table border="1"> <tr><td>72</td><td>71</td><td>70</td><td>69</td><td></td><td>67</td><td></td><td></td><td>64</td><td>63</td><td></td><td></td><td>60</td><td>59</td><td></td><td></td><td>56</td><td>55</td><td>54</td><td>53</td></tr> <tr><td>52</td><td>51</td><td></td><td>49</td><td></td><td>47</td><td></td><td>45</td><td>44</td><td>43</td><td>42</td><td>41</td><td></td><td></td><td></td><td></td><td>36</td><td></td><td></td><td>34</td></tr> <tr><td></td><td></td><td></td><td></td><td>73</td><td></td><td>32</td><td></td><td>30</td><td></td><td>28</td><td>26</td><td></td><td></td><td>23</td><td></td><td></td><td></td><td>19</td><td>18</td></tr> <tr><td></td><td></td><td></td><td></td><td></td><td></td><td>16</td><td>15</td><td></td><td></td><td>12</td><td></td><td>10</td><td></td><td></td><td></td><td></td><td></td><td>3</td><td></td></tr> </table>	72	71	70	69		67			64	63			60	59			56	55	54	53	52	51		49		47		45	44	43	42	41					36			34					73		32		30		28	26			23				19	18							16	15			12		10						3		
72	71	70	69		67			64	63			60	59			56	55	54	53																																																																					
52	51		49		47		45	44	43	42	41					36			34																																																																					
				73		32		30		28	26			23				19	18																																																																					
						16	15			12		10						3																																																																						
AVAILABLE	NOT APPLICABLE	34566-4723	G	0	A	BLACK	<table border="1"> <tr><td>72</td><td>71</td><td>70</td><td>69</td><td></td><td></td><td></td><td></td><td>64</td><td>63</td><td></td><td></td><td>60</td><td>59</td><td>58</td><td></td><td>56</td><td>55</td><td>54</td><td>53</td></tr> <tr><td>52</td><td>51</td><td></td><td>49</td><td></td><td>47</td><td></td><td>45</td><td>44</td><td>43</td><td>42</td><td>41</td><td></td><td></td><td></td><td></td><td>36</td><td></td><td></td><td>34</td></tr> <tr><td></td><td></td><td></td><td></td><td>73</td><td></td><td>32</td><td></td><td>30</td><td></td><td>28</td><td>26</td><td></td><td></td><td></td><td></td><td></td><td></td><td>19</td><td>18</td></tr> <tr><td></td><td></td><td></td><td></td><td></td><td></td><td>16</td><td>15</td><td></td><td></td><td>12</td><td></td><td>10</td><td></td><td></td><td></td><td></td><td></td><td>3</td><td></td></tr> </table>	72	71	70	69					64	63			60	59	58		56	55	54	53	52	51		49		47		45	44	43	42	41					36			34					73		32		30		28	26							19	18							16	15			12		10						3		
72	71	70	69					64	63			60	59	58		56	55	54	53																																																																					
52	51		49		47		45	44	43	42	41					36			34																																																																					
				73		32		30		28	26							19	18																																																																					
						16	15			12		10						3																																																																						
AVAILABLE	NOT APPLICABLE	34566-4733	G	0	A	BLACK	<table border="1"> <tr><td>72</td><td>71</td><td>70</td><td>69</td><td></td><td></td><td></td><td></td><td>64</td><td>63</td><td></td><td></td><td>60</td><td>59</td><td>58</td><td></td><td>56</td><td>55</td><td>54</td><td>53</td></tr> <tr><td>52</td><td>51</td><td></td><td>49</td><td></td><td>47</td><td></td><td>45</td><td>44</td><td>43</td><td>42</td><td>41</td><td></td><td></td><td></td><td></td><td>36</td><td></td><td></td><td>34</td></tr> <tr><td></td><td></td><td></td><td></td><td>73</td><td></td><td>32</td><td></td><td>30</td><td></td><td>28</td><td>26</td><td></td><td></td><td></td><td>21</td><td>19</td><td>18</td><td></td><td></td></tr> <tr><td></td><td></td><td></td><td></td><td></td><td></td><td>16</td><td>15</td><td></td><td></td><td>12</td><td></td><td>10</td><td>8</td><td></td><td>5</td><td></td><td>3</td><td></td><td></td></tr> </table>	72	71	70	69					64	63			60	59	58		56	55	54	53	52	51		49		47		45	44	43	42	41					36			34					73		32		30		28	26				21	19	18									16	15			12		10	8		5		3			
72	71	70	69					64	63			60	59	58		56	55	54	53																																																																					
52	51		49		47		45	44	43	42	41					36			34																																																																					
				73		32		30		28	26				21	19	18																																																																							
						16	15			12		10	8		5		3																																																																							
AVAILABLE	NOT APPLICABLE	34566-4743	G	9	A	BLACK	<table border="1"> <tr><td>72</td><td>71</td><td>70</td><td>69</td><td></td><td>67</td><td></td><td>65</td><td>64</td><td>63</td><td>62</td><td>61</td><td>60</td><td>59</td><td>58</td><td>57</td><td>56</td><td>55</td><td>54</td><td>53</td></tr> <tr><td>52</td><td>51</td><td>50</td><td>49</td><td>48</td><td>47</td><td></td><td>45</td><td>44</td><td>43</td><td>42</td><td>41</td><td>40</td><td>39</td><td></td><td>37</td><td>36</td><td></td><td></td><td>34</td></tr> <tr><td></td><td></td><td></td><td></td><td>73</td><td></td><td>32</td><td></td><td>30</td><td>29</td><td>28</td><td>27</td><td>26</td><td></td><td>24</td><td>23</td><td>21</td><td>19</td><td>18</td><td>17</td></tr> <tr><td></td><td></td><td></td><td></td><td></td><td></td><td>16</td><td>15</td><td>14</td><td>13</td><td>12</td><td>11</td><td>10</td><td>8</td><td></td><td>5</td><td></td><td>3</td><td>2</td><td>1</td></tr> </table>	72	71	70	69		67		65	64	63	62	61	60	59	58	57	56	55	54	53	52	51	50	49	48	47		45	44	43	42	41	40	39		37	36			34					73		32		30	29	28	27	26		24	23	21	19	18	17							16	15	14	13	12	11	10	8		5		3	2	1	
72	71	70	69		67		65	64	63	62	61	60	59	58	57	56	55	54	53																																																																					
52	51	50	49	48	47		45	44	43	42	41	40	39		37	36			34																																																																					
				73		32		30	29	28	27	26		24	23	21	19	18	17																																																																					
						16	15	14	13	12	11	10	8		5		3	2	1																																																																					
AVAILABLE	NOT APPLICABLE	34566-4753	G	0	B	ST.GRAY	<table border="1"> <tr><td></td><td></td><td></td><td></td><td>68</td><td>67</td><td></td><td></td><td>64</td><td></td><td></td><td></td><td></td><td></td><td></td><td></td><td>58</td><td></td><td></td><td></td></tr> <tr><td></td><td></td><td></td><td></td><td></td><td></td><td>46</td><td>45</td><td></td><td></td><td></td><td></td><td></td><td></td><td></td><td>38</td><td></td><td></td><td></td><td></td></tr> <tr><td></td><td></td><td></td><td></td><td>73</td><td></td><td>32</td><td></td><td>30</td><td>29</td><td>28</td><td>27</td><td></td><td></td><td></td><td>22</td><td></td><td></td><td></td><td>17</td></tr> <tr><td></td><td></td><td></td><td></td><td></td><td></td><td>15</td><td></td><td>13</td><td></td><td></td><td>10</td><td></td><td></td><td>6</td><td></td><td></td><td></td><td></td><td>1</td></tr> </table>					68	67			64								58										46	45								38									73		32		30	29	28	27				22				17							15		13			10			6					1	
				68	67			64								58																																																																								
						46	45								38																																																																									
				73		32		30	29	28	27				22				17																																																																					
						15		13			10			6					1																																																																					
AVAILABLE	NOT APPLICABLE	34566-4763	G	0	B	ST.GRAY	<table border="1"> <tr><td></td><td></td><td></td><td></td><td>68</td><td>67</td><td></td><td></td><td>64</td><td></td><td></td><td></td><td></td><td></td><td></td><td></td><td></td><td></td><td></td><td></td></tr> <tr><td></td><td></td><td></td><td></td><td></td><td></td><td>46</td><td>45</td><td></td><td></td><td></td><td></td><td></td><td></td><td></td><td></td><td></td><td></td><td></td><td>17</td></tr> <tr><td></td><td></td><td></td><td></td><td>73</td><td></td><td>32</td><td></td><td>30</td><td>29</td><td>28</td><td>27</td><td></td><td></td><td></td><td></td><td></td><td></td><td></td><td></td></tr> <tr><td></td><td></td><td></td><td></td><td></td><td></td><td>15</td><td></td><td>13</td><td></td><td></td><td>10</td><td></td><td></td><td>6</td><td></td><td></td><td></td><td></td><td></td></tr> </table>					68	67			64																		46	45												17					73		32		30	29	28	27															15		13			10			6						
				68	67			64																																																																																
						46	45												17																																																																					
				73		32		30	29	28	27																																																																													
						15		13			10			6																																																																										
AVAILABLE	NOT APPLICABLE	34566-4773	G	0	B	ST.GRAY	<table border="1"> <tr><td></td><td></td><td></td><td></td><td>68</td><td>67</td><td></td><td></td><td>64</td><td></td><td></td><td></td><td></td><td></td><td>59</td><td>58</td><td></td><td></td><td></td><td>54</td></tr> <tr><td></td><td></td><td></td><td></td><td></td><td></td><td>46</td><td>45</td><td></td><td></td><td></td><td></td><td></td><td></td><td>39</td><td>38</td><td></td><td></td><td></td><td></td></tr> <tr><td></td><td></td><td></td><td></td><td>73</td><td></td><td>32</td><td></td><td>30</td><td>29</td><td>28</td><td>27</td><td></td><td></td><td>23</td><td>22</td><td></td><td></td><td></td><td>17</td></tr> <tr><td></td><td></td><td></td><td></td><td></td><td></td><td>15</td><td></td><td>13</td><td></td><td></td><td>10</td><td>8</td><td>6</td><td></td><td></td><td></td><td></td><td></td><td>1</td></tr> </table>					68	67			64						59	58				54							46	45							39	38									73		32		30	29	28	27			23	22				17							15		13			10	8	6						1	
				68	67			64						59	58				54																																																																					
						46	45							39	38																																																																									
				73		32		30	29	28	27			23	22				17																																																																					
						15		13			10	8	6						1																																																																					

ENTER DESCRIPTION EC NO: UAU2014-0574 DRWNSKRAJENDRANA 2013/10/08 CHKD: APPR:VKOSHY 2013/10/09 REV	QUALITY SYMBOLS	GENERAL TOLERANCES (UNLESS SPECIFIED)	DIMENSION STYLE	SCALE	DESIGN UNITS	THIRD ANGLE PROJECTION	
	$\nabla=0$ $\nabla=0$ $\nabla=0$	mm INCH 4 PLACES ± --- ± --- 3 PLACES ± --- ± --- 2 PLACES ± --- ± --- 1 PLACE ± --- ± --- 0 PLACE ± --- ± ---	MM ONLY	1:1	METRIC	DRAWN BY: SKRAJENDRANA 2011/02/14 CHECKED BY: MVANSLAMBROU 2011/02/14 APPROVED BY:	TITLE: MX123 66/73/80CKT HRNS CONN ASSY molex
	ANGULAR ± ---° DRAFT WHERE APPLICABLE MUST REMAIN WITHIN DIMENSIONS	MATERIAL NO. SEE BOM TABLE DOCUMENT NO. SD-34566-001	SHEET NO. 54 OF 68	THIS DRAWING CONTAINS INFORMATION THAT IS PROPRIETARY TO MOLEX INCORPORATED AND SHOULD NOT BE USED WITHOUT WRITTEN PERMISSION			

STATUS	GM PART #	MATERIAL #	PART/ MATERIAL REVISION	WIRE DRESS OPTION	KEY OPTION ▽=0	COLOR (TPA) ▽=0	NUMBERS INDICATE CAVITIES OPEN FOR CIRCUITS ▽																																																																															
AVAILABLE	NOT APPLICABLE	34566-4783	G	0	B	ST.GRY	<table border="1"> <tr><td></td><td></td><td></td><td>68</td><td>67</td><td></td><td></td><td>64</td><td>63</td><td></td><td></td><td></td><td></td><td>58</td><td></td><td>55</td><td></td><td></td></tr> <tr><td></td><td></td><td></td><td></td><td></td><td>46</td><td>45</td><td></td><td>43</td><td></td><td></td><td></td><td></td><td>38</td><td></td><td>35</td><td></td><td></td></tr> <tr><td>73</td><td></td><td></td><td>32</td><td>31</td><td>30</td><td>29</td><td>28</td><td>27</td><td></td><td></td><td></td><td></td><td>22</td><td></td><td>19</td><td></td><td>17</td></tr> <tr><td></td><td></td><td></td><td></td><td>15</td><td></td><td>13</td><td></td><td></td><td>10</td><td></td><td></td><td></td><td>6</td><td></td><td></td><td></td><td>1</td></tr> </table>				68	67			64	63					58		55								46	45		43					38		35			73			32	31	30	29	28	27					22		19		17					15		13			10				6				1							
			68	67			64	63					58		55																																																																							
					46	45		43					38		35																																																																							
73			32	31	30	29	28	27					22		19		17																																																																					
				15		13			10				6				1																																																																					
AVAILABLE	NOT APPLICABLE	34566-4793	G	0	B	ST.GRY	<table border="1"> <tr><td></td><td></td><td></td><td>68</td><td>67</td><td></td><td></td><td>64</td><td>63</td><td></td><td></td><td></td><td></td><td>58</td><td></td><td></td><td></td><td></td></tr> <tr><td></td><td></td><td></td><td></td><td></td><td>46</td><td>45</td><td></td><td>43</td><td></td><td></td><td></td><td></td><td>38</td><td></td><td></td><td></td><td></td></tr> <tr><td>73</td><td></td><td></td><td>32</td><td>31</td><td>30</td><td>29</td><td>28</td><td>27</td><td></td><td></td><td></td><td></td><td>22</td><td></td><td>19</td><td></td><td>17</td></tr> <tr><td></td><td></td><td></td><td></td><td>15</td><td></td><td>13</td><td></td><td></td><td>10</td><td></td><td></td><td></td><td>6</td><td></td><td></td><td></td><td></td></tr> </table>				68	67			64	63					58										46	45		43					38					73			32	31	30	29	28	27					22		19		17					15		13			10				6											
			68	67			64	63					58																																																																									
					46	45		43					38																																																																									
73			32	31	30	29	28	27					22		19		17																																																																					
				15		13			10				6																																																																									
AVAILABLE	NOT APPLICABLE	34566-4813	G	9	B	ST.GRY	<table border="1"> <tr><td></td><td></td><td></td><td>68</td><td>67</td><td></td><td></td><td>64</td><td></td><td></td><td></td><td></td><td></td><td>59</td><td>58</td><td></td><td></td><td>54</td></tr> <tr><td></td><td></td><td></td><td></td><td></td><td>46</td><td>45</td><td></td><td></td><td></td><td></td><td></td><td></td><td>39</td><td>38</td><td></td><td></td><td></td></tr> <tr><td>73</td><td></td><td></td><td>32</td><td>31</td><td>30</td><td>29</td><td>28</td><td>27</td><td></td><td></td><td></td><td></td><td>23</td><td>22</td><td></td><td></td><td>17</td></tr> <tr><td></td><td></td><td></td><td></td><td>15</td><td></td><td>13</td><td></td><td></td><td>10</td><td>9</td><td>8</td><td></td><td>6</td><td></td><td></td><td></td><td>1</td></tr> </table>				68	67			64						59	58			54						46	45							39	38				73			32	31	30	29	28	27					23	22			17					15		13			10	9	8		6				1							
			68	67			64						59	58			54																																																																					
					46	45							39	38																																																																								
73			32	31	30	29	28	27					23	22			17																																																																					
				15		13			10	9	8		6				1																																																																					
AVAILABLE	NOT APPLICABLE	34566-4823	G	0	C	BLUE	<table border="1"> <tr><td></td><td></td><td></td><td>68</td><td>67</td><td>66</td><td>65</td><td>64</td><td></td><td></td><td></td><td></td><td></td><td>59</td><td>58</td><td>57</td><td>55</td><td>54</td><td>53</td></tr> <tr><td>51</td><td>50</td><td>49</td><td>48</td><td>47</td><td>46</td><td>45</td><td></td><td>43</td><td>42</td><td>41</td><td>40</td><td>39</td><td>38</td><td>37</td><td></td><td>35</td><td></td><td>33</td></tr> <tr><td>73</td><td></td><td></td><td>32</td><td>31</td><td>30</td><td></td><td></td><td>26</td><td>25</td><td>24</td><td>23</td><td>22</td><td></td><td>20</td><td></td><td></td><td></td><td></td></tr> <tr><td></td><td></td><td></td><td></td><td>16</td><td></td><td></td><td>13</td><td></td><td>10</td><td>9</td><td>8</td><td>7</td><td>6</td><td>5</td><td>4</td><td>3</td><td>2</td><td></td></tr> </table>				68	67	66	65	64						59	58	57	55	54	53	51	50	49	48	47	46	45		43	42	41	40	39	38	37		35		33	73			32	31	30			26	25	24	23	22		20									16			13		10	9	8	7	6	5	4	3	2				
			68	67	66	65	64						59	58	57	55	54	53																																																																				
51	50	49	48	47	46	45		43	42	41	40	39	38	37		35		33																																																																				
73			32	31	30			26	25	24	23	22		20																																																																								
				16			13		10	9	8	7	6	5	4	3	2																																																																					
AVAILABLE	NOT APPLICABLE	34566-4833	G	0	C	BLUE	<table border="1"> <tr><td>72</td><td>70</td><td></td><td>68</td><td>67</td><td>66</td><td></td><td></td><td>63</td><td>62</td><td></td><td></td><td></td><td>59</td><td>57</td><td></td><td></td><td></td><td>53</td></tr> <tr><td>52</td><td>51</td><td></td><td>48</td><td>47</td><td>46</td><td>44</td><td></td><td>42</td><td></td><td>40</td><td>39</td><td></td><td>37</td><td>36</td><td></td><td></td><td></td><td>34</td><td>33</td></tr> <tr><td>73</td><td></td><td></td><td>32</td><td>31</td><td>30</td><td></td><td></td><td>27</td><td>26</td><td>25</td><td>24</td><td></td><td>22</td><td>21</td><td></td><td></td><td></td><td></td><td></td></tr> <tr><td></td><td></td><td></td><td></td><td>15</td><td>14</td><td></td><td></td><td></td><td>10</td><td>9</td><td>8</td><td></td><td>6</td><td>5</td><td>4</td><td></td><td></td><td></td><td>2</td></tr> </table>	72	70		68	67	66			63	62				59	57				53	52	51		48	47	46	44		42		40	39		37	36				34	33	73			32	31	30			27	26	25	24		22	21										15	14				10	9	8		6	5	4				2
72	70		68	67	66			63	62				59	57				53																																																																				
52	51		48	47	46	44		42		40	39		37	36				34	33																																																																			
73			32	31	30			27	26	25	24		22	21																																																																								
				15	14				10	9	8		6	5	4				2																																																																			
AVAILABLE	NOT APPLICABLE	34566-4843	G	0	C	BLUE	<table border="1"> <tr><td>72</td><td>70</td><td></td><td>68</td><td>67</td><td>66</td><td></td><td></td><td>63</td><td>62</td><td></td><td></td><td></td><td>59</td><td>57</td><td></td><td></td><td></td><td>53</td></tr> <tr><td>52</td><td>51</td><td></td><td>48</td><td>47</td><td>46</td><td>44</td><td></td><td>42</td><td></td><td>40</td><td>39</td><td></td><td>37</td><td>36</td><td></td><td></td><td></td><td>34</td><td>33</td></tr> <tr><td>73</td><td></td><td></td><td>32</td><td>31</td><td>30</td><td></td><td></td><td>27</td><td>26</td><td>25</td><td>24</td><td></td><td>22</td><td>21</td><td></td><td></td><td></td><td></td><td></td></tr> <tr><td></td><td></td><td></td><td></td><td>15</td><td>14</td><td></td><td></td><td></td><td>10</td><td>9</td><td>8</td><td></td><td>6</td><td>5</td><td>4</td><td></td><td></td><td></td><td>2</td></tr> </table>	72	70		68	67	66			63	62				59	57				53	52	51		48	47	46	44		42		40	39		37	36				34	33	73			32	31	30			27	26	25	24		22	21										15	14				10	9	8		6	5	4				2
72	70		68	67	66			63	62				59	57				53																																																																				
52	51		48	47	46	44		42		40	39		37	36				34	33																																																																			
73			32	31	30			27	26	25	24		22	21																																																																								
				15	14				10	9	8		6	5	4				2																																																																			
AVAILABLE	NOT APPLICABLE	34566-4853	G	0	C	BLUE	<table border="1"> <tr><td>72</td><td>70</td><td></td><td>68</td><td></td><td>66</td><td></td><td></td><td>63</td><td>62</td><td></td><td></td><td></td><td>59</td><td>57</td><td>56</td><td>55</td><td></td><td>53</td></tr> <tr><td>52</td><td>51</td><td></td><td>48</td><td>47</td><td>46</td><td>44</td><td></td><td>42</td><td></td><td>40</td><td>39</td><td></td><td>37</td><td>36</td><td></td><td></td><td></td><td>34</td><td>33</td></tr> <tr><td>73</td><td></td><td></td><td>32</td><td>31</td><td>30</td><td></td><td></td><td>27</td><td>26</td><td>25</td><td>24</td><td></td><td>22</td><td>21</td><td></td><td></td><td></td><td>19</td><td>18</td></tr> <tr><td></td><td></td><td></td><td></td><td>15</td><td>14</td><td></td><td></td><td></td><td>10</td><td>9</td><td>8</td><td></td><td>6</td><td>5</td><td>4</td><td>3</td><td>2</td><td></td><td></td></tr> </table>	72	70		68		66			63	62				59	57	56	55		53	52	51		48	47	46	44		42		40	39		37	36				34	33	73			32	31	30			27	26	25	24		22	21				19	18					15	14				10	9	8		6	5	4	3	2		
72	70		68		66			63	62				59	57	56	55		53																																																																				
52	51		48	47	46	44		42		40	39		37	36				34	33																																																																			
73			32	31	30			27	26	25	24		22	21				19	18																																																																			
				15	14				10	9	8		6	5	4	3	2																																																																					
AVAILABLE	NOT APPLICABLE	34566-4863	G	0	C	BLUE	<table border="1"> <tr><td>72</td><td>70</td><td></td><td>68</td><td></td><td>66</td><td></td><td></td><td>63</td><td>62</td><td></td><td></td><td></td><td>59</td><td>57</td><td></td><td></td><td></td><td>53</td></tr> <tr><td>52</td><td>51</td><td></td><td>48</td><td>47</td><td>46</td><td>44</td><td></td><td>42</td><td></td><td>40</td><td>39</td><td></td><td>37</td><td>36</td><td></td><td></td><td></td><td>34</td><td>33</td></tr> <tr><td>73</td><td></td><td></td><td>32</td><td>31</td><td>30</td><td></td><td></td><td>27</td><td>26</td><td>25</td><td>24</td><td></td><td>22</td><td>21</td><td></td><td></td><td></td><td></td><td></td></tr> <tr><td></td><td></td><td></td><td></td><td>15</td><td>14</td><td></td><td></td><td></td><td>10</td><td>9</td><td>8</td><td></td><td>6</td><td>5</td><td>4</td><td></td><td></td><td></td><td>2</td></tr> </table>	72	70		68		66			63	62				59	57				53	52	51		48	47	46	44		42		40	39		37	36				34	33	73			32	31	30			27	26	25	24		22	21										15	14				10	9	8		6	5	4				2
72	70		68		66			63	62				59	57				53																																																																				
52	51		48	47	46	44		42		40	39		37	36				34	33																																																																			
73			32	31	30			27	26	25	24		22	21																																																																								
				15	14				10	9	8		6	5	4				2																																																																			
AVAILABLE	NOT APPLICABLE	34566-4873	G	0	C	BLUE	<table border="1"> <tr><td>72</td><td>70</td><td></td><td>68</td><td></td><td>66</td><td></td><td></td><td>63</td><td>62</td><td></td><td></td><td></td><td>59</td><td>57</td><td></td><td></td><td></td><td>53</td></tr> <tr><td>52</td><td>51</td><td></td><td>48</td><td>47</td><td>46</td><td>44</td><td></td><td>42</td><td></td><td>40</td><td>39</td><td></td><td>37</td><td>36</td><td></td><td></td><td></td><td>34</td><td>33</td></tr> <tr><td>73</td><td></td><td></td><td>32</td><td>31</td><td>30</td><td></td><td></td><td>27</td><td>26</td><td>25</td><td>24</td><td></td><td>22</td><td>21</td><td></td><td></td><td></td><td></td><td></td></tr> <tr><td></td><td></td><td></td><td></td><td>15</td><td>14</td><td></td><td></td><td></td><td>10</td><td>9</td><td>8</td><td></td><td>6</td><td>5</td><td>4</td><td></td><td></td><td></td><td>2</td></tr> </table>	72	70		68		66			63	62				59	57				53	52	51		48	47	46	44		42		40	39		37	36				34	33	73			32	31	30			27	26	25	24		22	21										15	14				10	9	8		6	5	4				2
72	70		68		66			63	62				59	57				53																																																																				
52	51		48	47	46	44		42		40	39		37	36				34	33																																																																			
73			32	31	30			27	26	25	24		22	21																																																																								
				15	14				10	9	8		6	5	4				2																																																																			

ENTER DESCRIPTION EC NO: UAU2014-0574 DRAWN: SKRAJENDRANA 2013/10/08 CHKD: GO APPR: VIOSHY 2013/10/09 REV:	QUALITY SYMBOLS	GENERAL TOLERANCES (UNLESS SPECIFIED)	DIMENSION STYLE	SCALE	DESIGN UNITS	THIRD ANGLE PROJECTION
	▽=0	mm INCH	MM ONLY	1:1	METRIC	
	▽=0	4 PLACES ± --- + ---	DRAWN BY: SKRAJENDRANA 2011/02/14	DATE	TITLE	
	▽=0	3 PLACES ± --- + ---	CHECKED BY: MVANSLAMBROU 2011/02/14	DATE		
▽=0	2 PLACES ± --- + ---	1 PLACE ± --- + ---	APPROVED BY: DATE			
	ANGULAR ± --- °	DRAFT WHERE APPLICABLE MUST REMAIN WITHIN DIMENSIONS	MATERIAL NO.	DOCUMENT NO.		
			SEE BOM TABLE	SD-34566-001		
			THIS DRAWING CONTAINS INFORMATION THAT IS PROPRIETARY TO MOLEX INCORPORATED AND SHOULD NOT BE USED WITHOUT WRITTEN PERMISSION			

MX123
66/73/80CKT
HRNS CONN ASSY

molex

SHEET NO.
55 OF 68

STATUS	GM PART #	MATERIAL #	PART/MATERIAL REVISION	WIRE DRESS OPTION	KEY OPTION	COLOR (TFA)	NUMBERS INDICATE CAVITIES OPEN FOR CIRCUITS																																																																								
AVAILABLE	NOT APPLICABLE	34566-4883	G	9	A	BLACK	<table border="1"> <tr><td>72</td><td></td><td>69</td><td>67</td><td>65</td><td>63</td><td></td><td>60</td><td></td><td>57</td><td>56</td><td></td><td>53</td></tr> <tr><td></td><td></td><td>49</td><td>47</td><td>46</td><td>44</td><td>43</td><td></td><td>40</td><td></td><td>37</td><td>36</td><td>35</td><td>33</td></tr> <tr><td></td><td>73</td><td></td><td>31</td><td>30</td><td>29</td><td>28</td><td></td><td>24</td><td></td><td>21</td><td>20</td><td></td><td>17</td></tr> <tr><td></td><td></td><td>16</td><td>15</td><td>14</td><td>13</td><td></td><td>11</td><td>10</td><td></td><td></td><td>5</td><td>4</td><td>3</td><td>2</td><td>1</td></tr> </table>	72		69	67	65	63		60		57	56		53			49	47	46	44	43		40		37	36	35	33		73		31	30	29	28		24		21	20		17			16	15	14	13		11	10			5	4	3	2	1															
72		69	67	65	63		60		57	56		53																																																																			
		49	47	46	44	43		40		37	36	35	33																																																																		
	73		31	30	29	28		24		21	20		17																																																																		
		16	15	14	13		11	10			5	4	3	2	1																																																																
AVAILABLE	NOT APPLICABLE	34566-4893	G	9	B	ST.GRAY	<table border="1"> <tr><td></td><td></td><td>68</td><td>67</td><td></td><td>64</td><td>63</td><td></td><td></td><td></td><td>58</td><td></td><td>55</td><td></td><td></td></tr> <tr><td></td><td></td><td></td><td>46</td><td>45</td><td>43</td><td></td><td></td><td></td><td></td><td>38</td><td></td><td>35</td><td></td><td></td></tr> <tr><td></td><td>73</td><td></td><td>32</td><td>30</td><td>29</td><td>28</td><td>27</td><td></td><td></td><td>22</td><td></td><td>19</td><td></td><td>17</td></tr> <tr><td></td><td></td><td></td><td>15</td><td>14</td><td>13</td><td></td><td></td><td>10</td><td></td><td></td><td></td><td></td><td></td><td></td><td>1</td></tr> </table>			68	67		64	63				58		55						46	45	43					38		35				73		32	30	29	28	27			22		19		17				15	14	13			10							1											
		68	67		64	63				58		55																																																																			
			46	45	43					38		35																																																																			
	73		32	30	29	28	27			22		19		17																																																																	
			15	14	13			10							1																																																																
AVAILABLE	NOT APPLICABLE	34566-4913	G	9	B	ST.GRAY	<table border="1"> <tr><td></td><td></td><td>68</td><td>67</td><td></td><td>64</td><td>63</td><td></td><td></td><td></td><td>58</td><td>57</td><td>55</td><td>53</td></tr> <tr><td></td><td></td><td></td><td>46</td><td>45</td><td>43</td><td></td><td></td><td></td><td></td><td>38</td><td>37</td><td>35</td><td></td></tr> <tr><td></td><td>73</td><td></td><td>32</td><td>30</td><td>29</td><td>28</td><td>27</td><td></td><td></td><td>22</td><td>21</td><td>19</td><td>17</td></tr> <tr><td></td><td></td><td></td><td></td><td></td><td></td><td>12</td><td>10</td><td></td><td></td><td></td><td></td><td></td><td></td><td></td><td>1</td></tr> </table>			68	67		64	63				58	57	55	53				46	45	43					38	37	35			73		32	30	29	28	27			22	21	19	17							12	10								1														
		68	67		64	63				58	57	55	53																																																																		
			46	45	43					38	37	35																																																																			
	73		32	30	29	28	27			22	21	19	17																																																																		
						12	10								1																																																																
AVAILABLE	NOT APPLICABLE	34566-4923	G	9	A	BLACK	<table border="1"> <tr><td>72</td><td></td><td>69</td><td>67</td><td>65</td><td>63</td><td></td><td>60</td><td></td><td>57</td><td>56</td><td></td><td>53</td></tr> <tr><td></td><td></td><td>49</td><td>47</td><td></td><td>44</td><td>43</td><td></td><td>40</td><td></td><td>37</td><td>36</td><td>35</td><td>33</td></tr> <tr><td></td><td>73</td><td></td><td>31</td><td>30</td><td>29</td><td>28</td><td></td><td></td><td>24</td><td></td><td>21</td><td>20</td><td>17</td></tr> <tr><td></td><td></td><td>16</td><td>15</td><td>14</td><td>13</td><td></td><td>11</td><td>10</td><td></td><td></td><td>5</td><td>4</td><td>3</td><td>2</td><td>1</td></tr> </table>	72		69	67	65	63		60		57	56		53			49	47		44	43		40		37	36	35	33		73		31	30	29	28			24		21	20	17			16	15	14	13		11	10			5	4	3	2	1															
72		69	67	65	63		60		57	56		53																																																																			
		49	47		44	43		40		37	36	35	33																																																																		
	73		31	30	29	28			24		21	20	17																																																																		
		16	15	14	13		11	10			5	4	3	2	1																																																																
AVAILABLE	NOT APPLICABLE	34566-4933	G	0	C	BLUE	<table border="1"> <tr><td>72</td><td>70</td><td>68</td><td>67</td><td>66</td><td>65</td><td>64</td><td>63</td><td>62</td><td>61</td><td>60</td><td>59</td><td>57</td><td></td><td>53</td></tr> <tr><td>52</td><td>51</td><td></td><td>48</td><td>47</td><td>46</td><td>44</td><td></td><td></td><td></td><td>40</td><td>39</td><td>37</td><td>36</td><td>35</td><td>34</td><td>33</td></tr> <tr><td></td><td></td><td></td><td>32</td><td>30</td><td></td><td></td><td>27</td><td>26</td><td>25</td><td>24</td><td></td><td>22</td><td>21</td><td></td><td></td><td></td></tr> <tr><td></td><td>73</td><td></td><td></td><td>15</td><td>14</td><td></td><td></td><td>10</td><td>9</td><td>8</td><td></td><td>6</td><td>5</td><td>4</td><td></td><td>2</td></tr> </table>	72	70	68	67	66	65	64	63	62	61	60	59	57		53	52	51		48	47	46	44				40	39	37	36	35	34	33				32	30			27	26	25	24		22	21					73			15	14			10	9	8		6	5	4		2						
72	70	68	67	66	65	64	63	62	61	60	59	57		53																																																																	
52	51		48	47	46	44				40	39	37	36	35	34	33																																																															
			32	30			27	26	25	24		22	21																																																																		
	73			15	14			10	9	8		6	5	4		2																																																															
AVAILABLE	NOT APPLICABLE	34566-4943	G	0	A	BLACK	<table border="1"> <tr><td></td><td>70</td><td>69</td><td>68</td><td>67</td><td></td><td></td><td>63</td><td>62</td><td>61</td><td>60</td><td>59</td><td>58</td><td>57</td><td>56</td><td>55</td><td>54</td><td>53</td></tr> <tr><td>52</td><td>51</td><td>50</td><td>49</td><td></td><td></td><td></td><td>44</td><td>43</td><td>42</td><td>41</td><td>39</td><td>38</td><td>37</td><td>36</td><td></td><td>34</td><td></td></tr> <tr><td></td><td></td><td></td><td>32</td><td>31</td><td></td><td>29</td><td>28</td><td>27</td><td>26</td><td>25</td><td></td><td>23</td><td></td><td></td><td>19</td><td>18</td><td></td></tr> <tr><td></td><td>73</td><td></td><td></td><td>16</td><td>15</td><td>14</td><td>13</td><td>12</td><td>11</td><td>10</td><td>9</td><td>8</td><td></td><td></td><td></td><td>3</td><td></td></tr> </table>		70	69	68	67			63	62	61	60	59	58	57	56	55	54	53	52	51	50	49				44	43	42	41	39	38	37	36		34					32	31		29	28	27	26	25		23			19	18			73			16	15	14	13	12	11	10	9	8				3	
	70	69	68	67			63	62	61	60	59	58	57	56	55	54	53																																																														
52	51	50	49				44	43	42	41	39	38	37	36		34																																																															
			32	31		29	28	27	26	25		23			19	18																																																															
	73			16	15	14	13	12	11	10	9	8				3																																																															
AVAILABLE	NOT APPLICABLE	34566-4953	G	0	B	ST.GRAY	<table border="1"> <tr><td>72</td><td>71</td><td>70</td><td>69</td><td>68</td><td>67</td><td>66</td><td>65</td><td>64</td><td>63</td><td></td><td>59</td><td></td><td></td><td></td><td></td><td>53</td></tr> <tr><td>52</td><td>51</td><td>50</td><td>49</td><td>48</td><td>47</td><td>46</td><td>45</td><td>44</td><td>43</td><td></td><td>39</td><td></td><td></td><td></td><td></td><td>34</td><td>33</td></tr> <tr><td></td><td></td><td></td><td>32</td><td>31</td><td>30</td><td>29</td><td>28</td><td>27</td><td>26</td><td>25</td><td>24</td><td>23</td><td></td><td></td><td>19</td><td>18</td><td>17</td></tr> <tr><td></td><td>73</td><td></td><td></td><td>16</td><td>15</td><td>14</td><td>13</td><td>12</td><td>11</td><td>10</td><td></td><td>8</td><td>7</td><td></td><td></td><td>3</td><td>2</td><td>1</td></tr> </table>	72	71	70	69	68	67	66	65	64	63		59					53	52	51	50	49	48	47	46	45	44	43		39					34	33				32	31	30	29	28	27	26	25	24	23			19	18	17		73			16	15	14	13	12	11	10		8	7			3	2	1
72	71	70	69	68	67	66	65	64	63		59					53																																																															
52	51	50	49	48	47	46	45	44	43		39					34	33																																																														
			32	31	30	29	28	27	26	25	24	23			19	18	17																																																														
	73			16	15	14	13	12	11	10		8	7			3	2	1																																																													
AVAILABLE	NOT APPLICABLE	34566-4963	G	9	A	BLACK	<table border="1"> <tr><td></td><td></td><td>69</td><td>67</td><td>66</td><td>65</td><td>63</td><td></td><td>60</td><td></td><td>57</td><td>56</td><td></td><td>53</td></tr> <tr><td></td><td></td><td>49</td><td>47</td><td>46</td><td>44</td><td>43</td><td>42</td><td>40</td><td></td><td>37</td><td>36</td><td>35</td><td>33</td></tr> <tr><td></td><td>73</td><td></td><td>31</td><td>30</td><td>29</td><td>28</td><td>27</td><td>26</td><td>24</td><td></td><td>21</td><td>20</td><td>17</td></tr> <tr><td></td><td></td><td>16</td><td>15</td><td>14</td><td>13</td><td></td><td>11</td><td>10</td><td></td><td></td><td>5</td><td>4</td><td>3</td><td>2</td><td>1</td></tr> </table>			69	67	66	65	63		60		57	56		53			49	47	46	44	43	42	40		37	36	35	33		73		31	30	29	28	27	26	24		21	20	17			16	15	14	13		11	10			5	4	3	2	1														
		69	67	66	65	63		60		57	56		53																																																																		
		49	47	46	44	43	42	40		37	36	35	33																																																																		
	73		31	30	29	28	27	26	24		21	20	17																																																																		
		16	15	14	13		11	10			5	4	3	2	1																																																																
AVAILABLE	NOT APPLICABLE	34566-4973	G	9	B	ST.GRAY	<table border="1"> <tr><td></td><td></td><td>68</td><td>67</td><td></td><td>64</td><td>63</td><td></td><td></td><td></td><td>59</td><td>58</td><td></td><td>54</td></tr> <tr><td></td><td></td><td></td><td>46</td><td>45</td><td>44</td><td>43</td><td></td><td></td><td></td><td>39</td><td>38</td><td></td><td>17</td></tr> <tr><td></td><td>73</td><td></td><td>32</td><td>30</td><td>29</td><td>28</td><td>27</td><td></td><td></td><td>23</td><td>22</td><td></td><td></td><td></td><td></td><td></td><td></td><td>1</td></tr> <tr><td></td><td></td><td></td><td>15</td><td>14</td><td>13</td><td>12</td><td>10</td><td></td><td></td><td>6</td><td></td><td></td><td></td><td></td><td></td><td></td><td></td><td></td></tr> </table>			68	67		64	63				59	58		54				46	45	44	43				39	38		17		73		32	30	29	28	27			23	22							1				15	14	13	12	10			6														
		68	67		64	63				59	58		54																																																																		
			46	45	44	43				39	38		17																																																																		
	73		32	30	29	28	27			23	22							1																																																													
			15	14	13	12	10			6																																																																					

ENTER DESCRIPTION IEC NO: UAU2014-0574 DRAWN BY: SKRAJENDRANA 2013/10/08 CHKD: MVANSLAMBROU APPR: VIKOSHY 2013/10/09 REV: 00	QUALITY SYMBOLS	GENERAL TOLERANCES (UNLESS SPECIFIED)	DIMENSION STYLE	SCALE	DESIGN UNITS	THIRD ANGLE PROJECTION
	▽=0	mm INCH	MM ONLY	1:1	METRIC	☉
	▽=0	4 PLACES ±--- ±---	DRAWN BY DATE			
	▽=0	3 PLACES ±--- ±---	SKRAJENDRANA 2011/02/14			
▽=0	2 PLACES ±--- ±---	CHECKED BY DATE				
	1 PLACE ±--- ±---	MVANSLAMBROU 2011/02/14				
	0 PLACE ±--- ±---	APPROVED BY DATE				
	ANGULAR ±---°	MATERIAL NO.	SEE BOM TABLE			
	DRAFT WHERE APPLICABLE MUST REMAIN WITHIN DIMENSIONS	DOCUMENT NO.				
		SD-34566-001				
		SHEET NO.				
		56 OF 68				

STATUS	GM PART #	MATERIAL #	PART/MATERIAL REVISION	WIRE DRESS OPTION	KEY OPTION	COLOR (TPA)	NUMBERS INDICATE CAVITIES OPEN FOR CIRCUITS																																																																																
AVAILABLE	NOT APPLICABLE	34566-4983	G	0	B	ST.GRAY	<table border="1"> <tr><td>72</td><td>70</td><td>68</td><td>66</td><td></td><td></td><td></td><td>60</td><td>59</td><td></td><td></td><td></td><td>55</td><td>54</td><td>53</td></tr> <tr><td>52</td><td>50</td><td>48</td><td>46</td><td>44</td><td></td><td></td><td>40</td><td>39</td><td></td><td></td><td></td><td>35</td><td>34</td><td>33</td></tr> <tr><td></td><td>73</td><td>32</td><td>31</td><td>30</td><td>29</td><td>28</td><td>27</td><td>26</td><td>25</td><td>24</td><td>23</td><td></td><td>19</td><td>18</td><td>17</td></tr> <tr><td></td><td></td><td>16</td><td></td><td></td><td></td><td></td><td></td><td>10</td><td></td><td>8</td><td>7</td><td></td><td></td><td>2</td><td>1</td></tr> </table>	72	70	68	66				60	59				55	54	53	52	50	48	46	44			40	39				35	34	33		73	32	31	30	29	28	27	26	25	24	23		19	18	17			16						10		8	7			2	1																		
72	70	68	66				60	59				55	54	53																																																																									
52	50	48	46	44			40	39				35	34	33																																																																									
	73	32	31	30	29	28	27	26	25	24	23		19	18	17																																																																								
		16						10		8	7			2	1																																																																								
AVAILABLE	NOT APPLICABLE	34566-4993	G	0	A	BLACK	<table border="1"> <tr><td>72</td><td>71</td><td>70</td><td>69</td><td></td><td>67</td><td></td><td>64</td><td>63</td><td></td><td>60</td><td>59</td><td></td><td>56</td><td>55</td><td>54</td><td>53</td></tr> <tr><td>52</td><td>51</td><td></td><td>49</td><td></td><td>47</td><td></td><td>45</td><td>44</td><td>43</td><td>42</td><td>41</td><td></td><td></td><td>36</td><td>34</td><td></td></tr> <tr><td></td><td></td><td></td><td>73</td><td></td><td>32</td><td></td><td>30</td><td>29</td><td>28</td><td>26</td><td></td><td></td><td></td><td></td><td>19</td><td>18</td></tr> <tr><td></td><td></td><td></td><td></td><td></td><td>16</td><td>15</td><td></td><td></td><td>12</td><td>10</td><td></td><td></td><td></td><td></td><td>3</td><td></td></tr> </table>	72	71	70	69		67		64	63		60	59		56	55	54	53	52	51		49		47		45	44	43	42	41			36	34					73		32		30	29	28	26					19	18						16	15			12	10					3													
72	71	70	69		67		64	63		60	59		56	55	54	53																																																																							
52	51		49		47		45	44	43	42	41			36	34																																																																								
			73		32		30	29	28	26					19	18																																																																							
					16	15			12	10					3																																																																								
AVAILABLE	NOT APPLICABLE	34566-5013	G	9	B	ST.GRAY	<table border="1"> <tr><td></td><td></td><td></td><td>68</td><td>67</td><td></td><td>64</td><td>63</td><td></td><td></td><td>59</td><td>58</td><td></td><td>55</td><td>54</td><td></td></tr> <tr><td></td><td></td><td></td><td></td><td></td><td>46</td><td>45</td><td>44</td><td>43</td><td></td><td>39</td><td>38</td><td></td><td>35</td><td></td><td></td></tr> <tr><td></td><td></td><td></td><td>73</td><td></td><td>32</td><td>30</td><td>29</td><td>28</td><td>27</td><td></td><td>23</td><td>22</td><td></td><td>19</td><td>17</td></tr> <tr><td></td><td></td><td></td><td></td><td></td><td>15</td><td>13</td><td>12</td><td></td><td>10</td><td></td><td></td><td>6</td><td></td><td></td><td>1</td></tr> </table>				68	67		64	63			59	58		55	54							46	45	44	43		39	38		35						73		32	30	29	28	27		23	22		19	17						15	13	12		10			6			1																
			68	67		64	63			59	58		55	54																																																																									
					46	45	44	43		39	38		35																																																																										
			73		32	30	29	28	27		23	22		19	17																																																																								
					15	13	12		10			6			1																																																																								
AVAILABLE	NOT APPLICABLE	34566-5023	G	0	C	BLUE	<table border="1"> <tr><td>72</td><td>70</td><td>68</td><td>67</td><td></td><td></td><td>63</td><td>62</td><td></td><td>59</td><td>57</td><td></td><td></td><td></td><td>53</td></tr> <tr><td>52</td><td>51</td><td></td><td>48</td><td>47</td><td>46</td><td>44</td><td>42</td><td>40</td><td>39</td><td>37</td><td>36</td><td></td><td>34</td><td>33</td></tr> <tr><td></td><td>73</td><td></td><td>32</td><td>30</td><td></td><td></td><td>26</td><td>25</td><td>24</td><td>22</td><td>21</td><td>20</td><td></td><td></td></tr> <tr><td></td><td></td><td></td><td>15</td><td>14</td><td></td><td></td><td></td><td>8</td><td>6</td><td>5</td><td>4</td><td></td><td></td><td>2</td></tr> </table>	72	70	68	67			63	62		59	57				53	52	51		48	47	46	44	42	40	39	37	36		34	33		73		32	30			26	25	24	22	21	20						15	14				8	6	5	4			2																				
72	70	68	67			63	62		59	57				53																																																																									
52	51		48	47	46	44	42	40	39	37	36		34	33																																																																									
	73		32	30			26	25	24	22	21	20																																																																											
			15	14				8	6	5	4			2																																																																									
AVAILABLE	NOT APPLICABLE	34566-5033	G	0	A	BLACK	<table border="1"> <tr><td></td><td>70</td><td>69</td><td></td><td></td><td></td><td>63</td><td>62</td><td>61</td><td>60</td><td></td><td>58</td><td>57</td><td>56</td><td>55</td><td>54</td><td>53</td></tr> <tr><td>52</td><td>51</td><td>49</td><td></td><td></td><td></td><td>44</td><td>43</td><td>42</td><td>41</td><td></td><td></td><td>37</td><td>36</td><td>35</td><td>34</td><td>33</td></tr> <tr><td></td><td>73</td><td></td><td>32</td><td></td><td>29</td><td>28</td><td>27</td><td>26</td><td>25</td><td></td><td></td><td></td><td></td><td>19</td><td>18</td><td></td></tr> <tr><td></td><td></td><td></td><td>16</td><td>15</td><td></td><td>13</td><td>12</td><td>11</td><td>10</td><td></td><td></td><td></td><td></td><td></td><td>3</td><td></td></tr> </table>		70	69				63	62	61	60		58	57	56	55	54	53	52	51	49				44	43	42	41			37	36	35	34	33		73		32		29	28	27	26	25					19	18					16	15		13	12	11	10						3													
	70	69				63	62	61	60		58	57	56	55	54	53																																																																							
52	51	49				44	43	42	41			37	36	35	34	33																																																																							
	73		32		29	28	27	26	25					19	18																																																																								
			16	15		13	12	11	10						3																																																																								
AVAILABLE	NOT APPLICABLE	34566-5043	G	0	A	BLACK	<table border="1"> <tr><td></td><td></td><td></td><td></td><td></td><td></td><td></td><td></td><td></td><td></td><td></td><td></td><td></td><td></td><td></td><td></td><td></td></tr> <tr><td></td><td></td><td></td><td></td><td></td><td></td><td></td><td></td><td></td><td></td><td></td><td></td><td></td><td></td><td></td><td></td><td></td></tr> <tr><td></td><td></td><td></td><td>73</td><td></td><td>31</td><td></td><td></td><td></td><td></td><td></td><td></td><td></td><td></td><td></td><td></td><td></td></tr> </table>																																						73		31																																								
			73		31																																																																																		
AVAILABLE	NOT APPLICABLE	34566-5053	G	0	B	ST.GRAY	<table border="1"> <tr><td></td><td></td><td></td><td></td><td></td><td></td><td></td><td></td><td></td><td></td><td></td><td></td><td></td><td></td><td></td><td></td><td></td></tr> <tr><td></td><td></td><td></td><td></td><td></td><td></td><td></td><td></td><td></td><td></td><td></td><td></td><td></td><td></td><td></td><td></td><td></td></tr> <tr><td></td><td></td><td></td><td>73</td><td></td><td>47</td><td></td><td></td><td></td><td></td><td></td><td></td><td></td><td></td><td></td><td>20</td><td>17</td></tr> <tr><td></td><td></td><td></td><td></td><td></td><td>31</td><td></td><td></td><td></td><td></td><td></td><td></td><td></td><td></td><td></td><td></td><td>1</td></tr> </table>																																						73		47										20	17						31											1												
			73		47										20	17																																																																							
					31											1																																																																							
AVAILABLE	NOT APPLICABLE	34566-5063	G	9	H	ST.GRAY	<table border="1"> <tr><td>80</td><td>79</td><td>78</td><td>77</td><td>76</td><td>75</td><td>74</td><td>73</td><td>72</td><td>71</td><td>70</td><td>69</td><td>68</td><td>67</td><td>66</td><td>65</td><td>64</td><td>63</td><td>62</td><td>61</td></tr> <tr><td>60</td><td>59</td><td>58</td><td>57</td><td>56</td><td>55</td><td>54</td><td>53</td><td>52</td><td>51</td><td>50</td><td>49</td><td>48</td><td>47</td><td>46</td><td>45</td><td>44</td><td>43</td><td>42</td><td>41</td></tr> <tr><td>40</td><td>39</td><td>38</td><td>37</td><td></td><td>35</td><td>34</td><td>33</td><td>32</td><td>30</td><td>29</td><td>27</td><td>26</td><td></td><td>24</td><td>23</td><td>22</td><td>21</td><td></td><td></td></tr> <tr><td>20</td><td>19</td><td>18</td><td>17</td><td></td><td>14</td><td>13</td><td>12</td><td>11</td><td>10</td><td>9</td><td>8</td><td></td><td>6</td><td>5</td><td></td><td>3</td><td>2</td><td></td><td></td></tr> </table>	80	79	78	77	76	75	74	73	72	71	70	69	68	67	66	65	64	63	62	61	60	59	58	57	56	55	54	53	52	51	50	49	48	47	46	45	44	43	42	41	40	39	38	37		35	34	33	32	30	29	27	26		24	23	22	21			20	19	18	17		14	13	12	11	10	9	8		6	5		3	2		
80	79	78	77	76	75	74	73	72	71	70	69	68	67	66	65	64	63	62	61																																																																				
60	59	58	57	56	55	54	53	52	51	50	49	48	47	46	45	44	43	42	41																																																																				
40	39	38	37		35	34	33	32	30	29	27	26		24	23	22	21																																																																						
20	19	18	17		14	13	12	11	10	9	8		6	5		3	2																																																																						
AVAILABLE	NOT APPLICABLE	34566-5073	G	9	A	BLACK	<table border="1"> <tr><td>72</td><td>71</td><td>70</td><td>69</td><td>68</td><td>67</td><td>66</td><td>65</td><td>64</td><td>63</td><td>62</td><td>61</td><td>60</td><td>59</td><td>58</td><td>57</td><td>56</td><td>55</td><td>54</td><td>53</td></tr> <tr><td>52</td><td>51</td><td>50</td><td>49</td><td>48</td><td>47</td><td>46</td><td>45</td><td>44</td><td>43</td><td>42</td><td>41</td><td>40</td><td>39</td><td>38</td><td>37</td><td>36</td><td></td><td>34</td><td>33</td></tr> <tr><td></td><td>73</td><td></td><td>32</td><td>31</td><td>30</td><td>29</td><td>28</td><td>27</td><td>26</td><td>24</td><td>23</td><td>22</td><td>21</td><td>20</td><td>19</td><td>18</td><td></td><td></td><td></td></tr> <tr><td></td><td></td><td></td><td>16</td><td></td><td></td><td>13</td><td>12</td><td>11</td><td>10</td><td>9</td><td>8</td><td></td><td></td><td></td><td></td><td></td><td></td><td></td><td>1</td></tr> </table>	72	71	70	69	68	67	66	65	64	63	62	61	60	59	58	57	56	55	54	53	52	51	50	49	48	47	46	45	44	43	42	41	40	39	38	37	36		34	33		73		32	31	30	29	28	27	26	24	23	22	21	20	19	18							16			13	12	11	10	9	8								1
72	71	70	69	68	67	66	65	64	63	62	61	60	59	58	57	56	55	54	53																																																																				
52	51	50	49	48	47	46	45	44	43	42	41	40	39	38	37	36		34	33																																																																				
	73		32	31	30	29	28	27	26	24	23	22	21	20	19	18																																																																							
			16			13	12	11	10	9	8								1																																																																				

ENTER DESCRIPTION IEC NO: UAU2014-0574 DRAWNS: SKRAJENDRANA 2013/10/08 CHKD: CHYK APPR: VKOSHY 2013/10/09 DESCRIPTION	QUALITY SYMBOLS	GENERAL TOLERANCES (UNLESS SPECIFIED)	DIMENSION STYLE	SCALE	DESIGN UNITS	THIRD ANGLE PROJECTION
	▽=0	mm INCH	MM ONLY	1:1	METRIC	
	▽=0	4 PLACES ± --- ± ---	DRAWN BY DATE			
	▽=0	3 PLACES ± --- ± ---	SKRAJENDRANA 2011/02/14			
▽=0	2 PLACES ± --- ± ---	CHECKED BY DATE				
▽=0	1 PLACE ± --- ± ---	MVANS LAMBROU 2011/02/14				
▽=0	0 PLACE ± --- ± ---	APPROVED BY DATE				
	ANGULAR ± ---	MATERIAL NO.				
	DRAFT WHERE APPLICABLE MUST REMAIN WITHIN DIMENSIONS	SEE BOM TABLE				
		SIZE D				

MX123
66/73/80CKT
HRNS CONN ASSY

SD-34566-001

SHEET NO. 57 OF 68

THIS DRAWING CONTAINS INFORMATION THAT IS PROPRIETARY TO MOLEX INCORPORATED AND SHOULD NOT BE USED WITHOUT WRITTEN PERMISSION

STATUS	GM PART #	MATERIAL #	PART/MATERIAL REVISION	WIRE DRESS OPTION	KEY OPTION	COLOR (TPA)	NUMBERS INDICATE CAVITIES OPEN FOR CIRCUITS																																																																																				
AVAILABLE	NOT APPLICABLE	34566-5183	G	0	B	ST.GRAY	<table border="1"> <tr><td></td><td></td><td></td><td>68</td><td>67</td><td></td><td>64</td><td></td><td></td><td></td><td>59</td><td>58</td><td></td><td></td><td>54</td></tr> <tr><td></td><td></td><td></td><td></td><td></td><td>46</td><td>45</td><td>44</td><td></td><td></td><td>39</td><td>38</td><td></td><td></td><td></td></tr> <tr><td></td><td>73</td><td></td><td>32</td><td></td><td>30</td><td>29</td><td>28</td><td>27</td><td></td><td></td><td>23</td><td>22</td><td></td><td>17</td></tr> <tr><td></td><td></td><td></td><td></td><td></td><td></td><td></td><td>12</td><td></td><td>10</td><td>8</td><td></td><td></td><td></td><td>1</td></tr> </table>				68	67		64				59	58			54						46	45	44			39	38					73		32		30	29	28	27			23	22		17								12		10	8				1																								
			68	67		64				59	58			54																																																																													
					46	45	44			39	38																																																																																
	73		32		30	29	28	27			23	22		17																																																																													
							12		10	8				1																																																																													
AVAILABLE	NOT APPLICABLE	34566-5193	G	0	A	BLACK	<table border="1"> <tr><td></td><td></td><td>70</td><td>69</td><td></td><td></td><td></td><td></td><td></td><td>63</td><td>62</td><td>61</td><td>60</td><td></td><td>58</td><td>57</td><td>56</td><td>55</td><td>54</td><td>53</td></tr> <tr><td>52</td><td>51</td><td></td><td>49</td><td></td><td></td><td></td><td></td><td>44</td><td>43</td><td>42</td><td>41</td><td></td><td></td><td></td><td>37</td><td>36</td><td></td><td>34</td><td></td></tr> <tr><td></td><td></td><td></td><td></td><td>32</td><td></td><td></td><td>29</td><td>28</td><td>27</td><td>26</td><td></td><td></td><td></td><td></td><td></td><td></td><td>19</td><td>18</td><td>17</td></tr> <tr><td></td><td>73</td><td></td><td></td><td>16</td><td>15</td><td></td><td>13</td><td>12</td><td>11</td><td>10</td><td></td><td></td><td></td><td></td><td></td><td></td><td>3</td><td>2</td><td>1</td></tr> </table>			70	69						63	62	61	60		58	57	56	55	54	53	52	51		49					44	43	42	41				37	36		34						32			29	28	27	26							19	18	17		73			16	15		13	12	11	10							3	2	1				
		70	69						63	62	61	60		58	57	56	55	54	53																																																																								
52	51		49					44	43	42	41				37	36		34																																																																									
				32			29	28	27	26							19	18	17																																																																								
	73			16	15		13	12	11	10							3	2	1																																																																								
AVAILABLE	NOT APPLICABLE	34566-5213	G	0	A	BLACK	<table border="1"> <tr><td>72</td><td>71</td><td>70</td><td>69</td><td>68</td><td>67</td><td>66</td><td>65</td><td>64</td><td>63</td><td>62</td><td>61</td><td>60</td><td>59</td><td></td><td></td><td></td><td>55</td><td>54</td><td>53</td></tr> <tr><td>52</td><td></td><td></td><td>49</td><td>48</td><td></td><td></td><td></td><td>44</td><td>43</td><td>42</td><td>41</td><td>40</td><td>39</td><td></td><td></td><td></td><td>35</td><td>34</td><td>33</td></tr> <tr><td></td><td></td><td></td><td></td><td>32</td><td></td><td></td><td>29</td><td>28</td><td>27</td><td>26</td><td>25</td><td>24</td><td>23</td><td></td><td></td><td></td><td>19</td><td>18</td><td>17</td></tr> <tr><td></td><td>73</td><td></td><td></td><td>16</td><td></td><td></td><td>13</td><td>12</td><td>11</td><td>10</td><td>9</td><td>8</td><td>7</td><td>6</td><td>5</td><td>4</td><td>3</td><td>2</td><td>1</td></tr> </table>	72	71	70	69	68	67	66	65	64	63	62	61	60	59				55	54	53	52			49	48				44	43	42	41	40	39				35	34	33					32			29	28	27	26	25	24	23				19	18	17		73			16			13	12	11	10	9	8	7	6	5	4	3	2	1				
72	71	70	69	68	67	66	65	64	63	62	61	60	59				55	54	53																																																																								
52			49	48				44	43	42	41	40	39				35	34	33																																																																								
				32			29	28	27	26	25	24	23				19	18	17																																																																								
	73			16			13	12	11	10	9	8	7	6	5	4	3	2	1																																																																								
AVAILABLE	NOT APPLICABLE	34566-5223	G	0	C	BLUE	<table border="1"> <tr><td>72</td><td>70</td><td></td><td></td><td>67</td><td>66</td><td></td><td></td><td></td><td>63</td><td>62</td><td></td><td></td><td>59</td><td></td><td>57</td><td></td><td></td><td></td><td>53</td></tr> <tr><td>52</td><td>51</td><td></td><td></td><td>48</td><td>46</td><td></td><td></td><td>44</td><td></td><td>42</td><td></td><td>40</td><td>39</td><td></td><td></td><td></td><td></td><td>34</td><td>33</td></tr> <tr><td></td><td></td><td></td><td></td><td>32</td><td>30</td><td></td><td></td><td>27</td><td>26</td><td>25</td><td></td><td></td><td></td><td>22</td><td>21</td><td></td><td></td><td></td><td></td></tr> <tr><td></td><td>73</td><td></td><td></td><td>15</td><td>14</td><td></td><td></td><td></td><td></td><td>10</td><td>9</td><td></td><td></td><td>6</td><td>5</td><td>4</td><td></td><td></td><td></td></tr> </table>	72	70			67	66				63	62			59		57				53	52	51			48	46			44		42		40	39					34	33					32	30			27	26	25				22	21						73			15	14					10	9			6	5	4							
72	70			67	66				63	62			59		57				53																																																																								
52	51			48	46			44		42		40	39					34	33																																																																								
				32	30			27	26	25				22	21																																																																												
	73			15	14					10	9			6	5	4																																																																											
AVAILABLE	NOT APPLICABLE	34566-5233	G	0	C	BLUE	<table border="1"> <tr><td>72</td><td>70</td><td></td><td></td><td>68</td><td>67</td><td>66</td><td></td><td></td><td>63</td><td>62</td><td></td><td></td><td>59</td><td></td><td>57</td><td>56</td><td>55</td><td></td><td>53</td></tr> <tr><td>52</td><td>51</td><td></td><td></td><td>48</td><td>47</td><td>46</td><td></td><td></td><td>44</td><td>42</td><td></td><td>40</td><td>39</td><td>38</td><td></td><td></td><td></td><td>34</td><td>33</td></tr> <tr><td></td><td></td><td></td><td></td><td>32</td><td>30</td><td></td><td></td><td></td><td></td><td>26</td><td>25</td><td></td><td></td><td></td><td>22</td><td>21</td><td></td><td>19</td><td>18</td></tr> <tr><td></td><td>73</td><td></td><td></td><td>15</td><td>14</td><td></td><td></td><td></td><td></td><td>10</td><td>9</td><td></td><td></td><td>6</td><td>5</td><td>4</td><td>3</td><td></td><td></td></tr> </table>	72	70			68	67	66			63	62			59		57	56	55		53	52	51			48	47	46			44	42		40	39	38				34	33					32	30					26	25				22	21		19	18		73			15	14					10	9			6	5	4	3						
72	70			68	67	66			63	62			59		57	56	55		53																																																																								
52	51			48	47	46			44	42		40	39	38				34	33																																																																								
				32	30					26	25				22	21		19	18																																																																								
	73			15	14					10	9			6	5	4	3																																																																										
AVAILABLE	NOT APPLICABLE	34566-5243	G	0	C	BLUE	<table border="1"> <tr><td>72</td><td>71</td><td>70</td><td>69</td><td>68</td><td>67</td><td>66</td><td>65</td><td></td><td>63</td><td>62</td><td>61</td><td></td><td>59</td><td>58</td><td>57</td><td>56</td><td>55</td><td>54</td><td>53</td></tr> <tr><td></td><td>51</td><td>50</td><td>49</td><td>48</td><td></td><td></td><td>46</td><td>45</td><td>44</td><td>43</td><td>42</td><td>41</td><td>40</td><td>39</td><td>38</td><td></td><td>36</td><td>35</td><td>34</td><td>33</td></tr> <tr><td></td><td></td><td></td><td></td><td></td><td></td><td></td><td>31</td><td>30</td><td>29</td><td>28</td><td>27</td><td>26</td><td>25</td><td></td><td></td><td>22</td><td>21</td><td>20</td><td>19</td><td>18</td><td>17</td></tr> <tr><td></td><td>73</td><td></td><td></td><td></td><td></td><td></td><td>16</td><td>15</td><td>14</td><td></td><td></td><td></td><td>9</td><td>7</td><td>6</td><td>5</td><td>4</td><td>3</td><td>2</td><td>1</td></tr> </table>	72	71	70	69	68	67	66	65		63	62	61		59	58	57	56	55	54	53		51	50	49	48			46	45	44	43	42	41	40	39	38		36	35	34	33								31	30	29	28	27	26	25			22	21	20	19	18	17		73						16	15	14				9	7	6	5	4	3	2	1
72	71	70	69	68	67	66	65		63	62	61		59	58	57	56	55	54	53																																																																								
	51	50	49	48			46	45	44	43	42	41	40	39	38		36	35	34	33																																																																							
							31	30	29	28	27	26	25			22	21	20	19	18	17																																																																						
	73						16	15	14				9	7	6	5	4	3	2	1																																																																							
AVAILABLE	NOT APPLICABLE	34566-5253	G	0	B	ST.GRAY	<table border="1"> <tr><td></td><td></td><td></td><td></td><td></td><td>67</td><td>66</td><td></td><td></td><td>63</td><td></td><td></td><td></td><td>59</td><td>58</td><td>57</td><td>56</td><td>55</td><td></td><td>53</td></tr> <tr><td></td><td></td><td>50</td><td>49</td><td>48</td><td></td><td>46</td><td>45</td><td>43</td><td></td><td></td><td></td><td></td><td>39</td><td>38</td><td>37</td><td>36</td><td>35</td><td>34</td><td>33</td></tr> <tr><td></td><td></td><td></td><td></td><td></td><td></td><td></td><td></td><td>29</td><td>27</td><td></td><td></td><td></td><td></td><td>23</td><td>22</td><td>21</td><td></td><td></td><td>18</td></tr> <tr><td></td><td>73</td><td></td><td></td><td></td><td></td><td></td><td></td><td></td><td></td><td></td><td></td><td></td><td>8</td><td>7</td><td>6</td><td>5</td><td>4</td><td>3</td><td></td></tr> </table>						67	66			63				59	58	57	56	55		53			50	49	48		46	45	43					39	38	37	36	35	34	33									29	27					23	22	21			18		73												8	7	6	5	4	3					
					67	66			63				59	58	57	56	55		53																																																																								
		50	49	48		46	45	43					39	38	37	36	35	34	33																																																																								
								29	27					23	22	21			18																																																																								
	73												8	7	6	5	4	3																																																																									
AVAILABLE	NOT APPLICABLE	34566-5263	G	0	B	ST.GRAY	<table border="1"> <tr><td>72</td><td>71</td><td>70</td><td></td><td>68</td><td>67</td><td>66</td><td></td><td></td><td></td><td>62</td><td>61</td><td>60</td><td>59</td><td>58</td><td>57</td><td>56</td><td>55</td><td>54</td><td>53</td></tr> <tr><td>52</td><td>51</td><td>50</td><td></td><td>48</td><td>47</td><td>46</td><td></td><td></td><td></td><td>42</td><td>41</td><td>40</td><td>39</td><td>38</td><td>37</td><td>36</td><td>35</td><td>34</td><td>33</td></tr> <tr><td></td><td></td><td></td><td></td><td>32</td><td>31</td><td>30</td><td>29</td><td>28</td><td>27</td><td></td><td>25</td><td>24</td><td></td><td></td><td></td><td></td><td></td><td></td><td>17</td></tr> <tr><td></td><td>73</td><td></td><td></td><td>16</td><td>15</td><td>14</td><td>13</td><td></td><td></td><td>10</td><td>8</td><td></td><td></td><td></td><td></td><td></td><td></td><td></td><td>2</td><td>1</td></tr> </table>	72	71	70		68	67	66				62	61	60	59	58	57	56	55	54	53	52	51	50		48	47	46				42	41	40	39	38	37	36	35	34	33					32	31	30	29	28	27		25	24							17		73			16	15	14	13			10	8								2	1			
72	71	70		68	67	66				62	61	60	59	58	57	56	55	54	53																																																																								
52	51	50		48	47	46				42	41	40	39	38	37	36	35	34	33																																																																								
				32	31	30	29	28	27		25	24							17																																																																								
	73			16	15	14	13			10	8								2	1																																																																							
AVAILABLE	NOT APPLICABLE	34566-5273	G	0	A	BLACK	<table border="1"> <tr><td></td><td></td><td>70</td><td>69</td><td></td><td></td><td></td><td></td><td></td><td>63</td><td>62</td><td>61</td><td>60</td><td></td><td>58</td><td>57</td><td>56</td><td>55</td><td>54</td><td>53</td></tr> <tr><td>52</td><td>51</td><td></td><td>49</td><td></td><td></td><td></td><td></td><td>44</td><td>43</td><td>42</td><td>41</td><td></td><td></td><td></td><td>37</td><td>36</td><td></td><td>34</td><td></td></tr> <tr><td></td><td></td><td></td><td></td><td>32</td><td></td><td></td><td>29</td><td>28</td><td>27</td><td>26</td><td></td><td></td><td>23</td><td></td><td></td><td></td><td></td><td>19</td><td>18</td></tr> <tr><td></td><td>73</td><td></td><td></td><td>16</td><td>15</td><td></td><td>13</td><td>12</td><td>11</td><td>10</td><td>9</td><td>8</td><td></td><td></td><td></td><td></td><td>3</td><td></td><td></td></tr> </table>			70	69						63	62	61	60		58	57	56	55	54	53	52	51		49					44	43	42	41				37	36		34						32			29	28	27	26			23					19	18		73			16	15		13	12	11	10	9	8					3						
		70	69						63	62	61	60		58	57	56	55	54	53																																																																								
52	51		49					44	43	42	41				37	36		34																																																																									
				32			29	28	27	26			23					19	18																																																																								
	73			16	15		13	12	11	10	9	8					3																																																																										

ENTER DESCRIPTION IEC NO. UAU2014-0574 DRAWN BY SKRA JENDRANA 2013/10/08 CHKD: MVANSLAMBROU APPR: VIKOSHY 2013/10/09 REV: 00	QUALITY SYMBOLS	GENERAL TOLERANCES (UNLESS SPECIFIED)	DIMENSION STYLE	SCALE	DESIGN UNITS	THIRD ANGLE PROJECTION
	▽=0	mm INCH	MM ONLY	1:1	METRIC	☉
	▽=0	4 PLACES #--- #---	DRAWN BY DATE	TITLE		
	▽=0	3 PLACES #--- #---	SKRA JENDRANA 2011/02/14	MX123 66/73/80CKT HRNS CONN ASSY		
▽=0	2 PLACES #--- #---	CHECKED BY DATE	MATERIAL NO.			DOCUMENT NO.
▽=0	1 PLACE #--- #---	MVANS LAMBROU 2011/02/14	SEE BOM			SD-34566-001
▽=0	0 PLACE #--- #---	APPROVED BY DATE	SIZE			SHEET NO.
	ANGULAR ±---		D			59 OF 68
	DRAFT WHERE APPLICABLE MUST REMAIN WITHIN DIMENSIONS	THIS DRAWING CONTAINS INFORMATION THAT IS PROPRIETARY TO MOLEX INCORPORATED AND SHOULD NOT BE USED WITHOUT WRITTEN PERMISSION				

STATUS	GM PART #	MATERIAL #	PART/MATERIAL REVISION	WIRE DRESS OPTION	KEY OPTION Fp	COLOR (TPA) Fp	NUMBERS INDICATE CAVITIES OPEN FOR CIRCUITS Fp																																																																				
AVAILABLE	NOT APPLICABLE	34566-5283	G	0	C	BLUE	<table border="1"> <tr><td>72</td><td>70</td><td>68</td><td>67</td><td>66</td><td></td><td>63</td><td>62</td><td></td><td>59</td><td>57</td><td>56</td><td>55</td><td>54</td><td>53</td></tr> <tr><td>52</td><td>51</td><td></td><td>48</td><td>47</td><td>46</td><td>44</td><td>42</td><td></td><td>40</td><td>39</td><td></td><td></td><td>34</td><td>33</td></tr> <tr><td></td><td>73</td><td></td><td>32</td><td>30</td><td></td><td></td><td>26</td><td>25</td><td></td><td></td><td>22</td><td>21</td><td>19</td><td>18</td></tr> <tr><td></td><td></td><td></td><td>15</td><td>14</td><td></td><td></td><td>10</td><td>9</td><td></td><td></td><td>6</td><td>5</td><td>4</td><td>3</td></tr> </table>	72	70	68	67	66		63	62		59	57	56	55	54	53	52	51		48	47	46	44	42		40	39			34	33		73		32	30			26	25			22	21	19	18				15	14			10	9			6	5	4	3								
72	70	68	67	66		63	62		59	57	56	55	54	53																																																													
52	51		48	47	46	44	42		40	39			34	33																																																													
	73		32	30			26	25			22	21	19	18																																																													
			15	14			10	9			6	5	4	3																																																													
AVAILABLE	NOT APPLICABLE	34566-5293	G	0	A	BLACK	<table border="1"> <tr><td></td><td>70</td><td>69</td><td></td><td></td><td></td><td>63</td><td>62</td><td>61</td><td>60</td><td></td><td>58</td><td>57</td><td>56</td><td>55</td><td>54</td><td>53</td></tr> <tr><td>52</td><td>51</td><td>49</td><td></td><td></td><td></td><td>44</td><td>43</td><td>42</td><td>41</td><td>40</td><td></td><td></td><td>37</td><td>36</td><td>34</td><td></td></tr> <tr><td></td><td>73</td><td></td><td>32</td><td></td><td>29</td><td>28</td><td>27</td><td>26</td><td></td><td></td><td></td><td></td><td></td><td>19</td><td>18</td><td>17</td></tr> <tr><td></td><td></td><td></td><td>16</td><td>15</td><td>13</td><td>12</td><td>11</td><td>10</td><td></td><td></td><td></td><td></td><td></td><td>3</td><td>2</td><td>1</td></tr> </table>		70	69				63	62	61	60		58	57	56	55	54	53	52	51	49				44	43	42	41	40			37	36	34			73		32		29	28	27	26						19	18	17				16	15	13	12	11	10						3	2	1
	70	69				63	62	61	60		58	57	56	55	54	53																																																											
52	51	49				44	43	42	41	40			37	36	34																																																												
	73		32		29	28	27	26						19	18	17																																																											
			16	15	13	12	11	10						3	2	1																																																											
AVAILABLE	NOT APPLICABLE	34566-5313	G	0	C	BLUE	<table border="1"> <tr><td>72</td><td>70</td><td>68</td><td>67</td><td>66</td><td></td><td>63</td><td>62</td><td></td><td>59</td><td>57</td><td>56</td><td>55</td><td>54</td><td>53</td></tr> <tr><td>52</td><td>51</td><td></td><td>48</td><td>47</td><td>46</td><td>44</td><td>42</td><td></td><td>40</td><td>39</td><td>38</td><td>37</td><td>36</td><td>34</td><td>33</td></tr> <tr><td></td><td>73</td><td></td><td>32</td><td>30</td><td></td><td>27</td><td>26</td><td>25</td><td>24</td><td></td><td>22</td><td>21</td><td>19</td><td>18</td></tr> <tr><td></td><td></td><td></td><td>15</td><td>14</td><td></td><td></td><td>10</td><td>9</td><td>8</td><td></td><td>6</td><td>5</td><td>4</td><td>3</td><td>2</td></tr> </table>	72	70	68	67	66		63	62		59	57	56	55	54	53	52	51		48	47	46	44	42		40	39	38	37	36	34	33		73		32	30		27	26	25	24		22	21	19	18				15	14			10	9	8		6	5	4	3	2						
72	70	68	67	66		63	62		59	57	56	55	54	53																																																													
52	51		48	47	46	44	42		40	39	38	37	36	34	33																																																												
	73		32	30		27	26	25	24		22	21	19	18																																																													
			15	14			10	9	8		6	5	4	3	2																																																												
AVAILABLE	NOT APPLICABLE	34566-5323	G	0	G	BLUE	<table border="1"> <tr><td>80</td><td>78</td><td>77</td><td>75</td><td>74</td><td>73</td><td>72</td><td>70</td><td>69</td><td>67</td><td>65</td><td>64</td><td>63</td><td>62</td><td></td><td></td></tr> <tr><td>60</td><td>58</td><td>57</td><td>55</td><td>54</td><td>52</td><td>51</td><td>50</td><td>49</td><td>47</td><td>45</td><td>44</td><td>43</td><td>42</td><td></td><td></td></tr> <tr><td>40</td><td>38</td><td>37</td><td></td><td></td><td></td><td>33</td><td>32</td><td>31</td><td></td><td>27</td><td>26</td><td>25</td><td>24</td><td></td><td></td></tr> <tr><td>20</td><td>18</td><td>17</td><td></td><td></td><td></td><td></td><td>10</td><td>9</td><td>8</td><td></td><td>6</td><td>5</td><td>4</td><td>3</td><td>2</td><td>1</td></tr> </table>	80	78	77	75	74	73	72	70	69	67	65	64	63	62			60	58	57	55	54	52	51	50	49	47	45	44	43	42			40	38	37				33	32	31		27	26	25	24			20	18	17					10	9	8		6	5	4	3	2	1			
80	78	77	75	74	73	72	70	69	67	65	64	63	62																																																														
60	58	57	55	54	52	51	50	49	47	45	44	43	42																																																														
40	38	37				33	32	31		27	26	25	24																																																														
20	18	17					10	9	8		6	5	4	3	2	1																																																											
AVAILABLE	NOT APPLICABLE	34566-5333	G	0	A	BLACK	<table border="1"> <tr><td>72</td><td>71</td><td>70</td><td>68</td><td>67</td><td>66</td><td>65</td><td>64</td><td>63</td><td>62</td><td>60</td><td>59</td><td></td><td>56</td><td></td><td>53</td></tr> <tr><td>51</td><td></td><td>49</td><td>48</td><td>47</td><td>46</td><td>45</td><td>44</td><td>43</td><td></td><td>41</td><td>40</td><td></td><td></td><td></td><td></td></tr> <tr><td></td><td>73</td><td></td><td></td><td></td><td>30</td><td>29</td><td>28</td><td></td><td>26</td><td>25</td><td>24</td><td></td><td></td><td>20</td><td></td><td>17</td></tr> <tr><td></td><td></td><td></td><td></td><td></td><td></td><td></td><td>12</td><td>11</td><td></td><td></td><td></td><td></td><td></td><td></td><td></td><td></td></tr> </table>	72	71	70	68	67	66	65	64	63	62	60	59		56		53	51		49	48	47	46	45	44	43		41	40						73				30	29	28		26	25	24			20		17								12	11										
72	71	70	68	67	66	65	64	63	62	60	59		56		53																																																												
51		49	48	47	46	45	44	43		41	40																																																																
	73				30	29	28		26	25	24			20		17																																																											
							12	11																																																																			
AVAILABLE	NOT APPLICABLE	34566-5343	G	0	B	ST.GRAY	<table border="1"> <tr><td></td><td></td><td></td><td>68</td><td>67</td><td></td><td>64</td><td></td><td></td><td></td><td>59</td><td>58</td><td></td><td></td><td>54</td><td></td></tr> <tr><td></td><td></td><td></td><td></td><td>46</td><td>45</td><td></td><td></td><td></td><td></td><td>39</td><td>38</td><td></td><td></td><td></td><td></td></tr> <tr><td></td><td>73</td><td></td><td>32</td><td>30</td><td>29</td><td>28</td><td>27</td><td></td><td></td><td>23</td><td>22</td><td></td><td></td><td></td><td>17</td></tr> <tr><td></td><td></td><td></td><td></td><td></td><td></td><td>12</td><td>10</td><td>8</td><td></td><td>6</td><td></td><td></td><td></td><td></td><td>1</td></tr> </table>				68	67		64				59	58			54						46	45					39	38						73		32	30	29	28	27			23	22				17							12	10	8		6					1				
			68	67		64				59	58			54																																																													
				46	45					39	38																																																																
	73		32	30	29	28	27			23	22				17																																																												
						12	10	8		6					1																																																												
AVAILABLE	NOT APPLICABLE	34566-5353	G	9	B	ST.GRAY	<table border="1"> <tr><td></td><td></td><td></td><td>68</td><td>67</td><td></td><td>64</td><td>63</td><td></td><td></td><td>59</td><td>58</td><td></td><td>55</td><td>54</td></tr> <tr><td></td><td></td><td></td><td></td><td>46</td><td>45</td><td>44</td><td>43</td><td></td><td></td><td>39</td><td>38</td><td></td><td>35</td><td>34</td></tr> <tr><td></td><td>73</td><td></td><td>32</td><td>30</td><td>29</td><td>28</td><td>27</td><td></td><td></td><td>23</td><td>22</td><td></td><td>19</td><td>17</td></tr> <tr><td></td><td></td><td></td><td>15</td><td>13</td><td>12</td><td>10</td><td></td><td></td><td></td><td>6</td><td></td><td></td><td></td><td>1</td></tr> </table>				68	67		64	63			59	58		55	54					46	45	44	43			39	38		35	34		73		32	30	29	28	27			23	22		19	17				15	13	12	10				6				1								
			68	67		64	63			59	58		55	54																																																													
				46	45	44	43			39	38		35	34																																																													
	73		32	30	29	28	27			23	22		19	17																																																													
			15	13	12	10				6				1																																																													
AVAILABLE	NOT APPLICABLE	34566-5363	G	0	C	BLUE	<table border="1"> <tr><td>72</td><td>70</td><td>68</td><td>66</td><td></td><td></td><td>63</td><td>62</td><td></td><td>59</td><td>57</td><td></td><td></td><td></td><td>53</td></tr> <tr><td>52</td><td>51</td><td></td><td>48</td><td>47</td><td>46</td><td>44</td><td>42</td><td></td><td>40</td><td>39</td><td>38</td><td></td><td></td><td>34</td><td>33</td></tr> <tr><td></td><td>73</td><td></td><td>32</td><td>30</td><td></td><td></td><td>26</td><td>25</td><td></td><td></td><td>22</td><td>21</td><td></td><td></td><td></td></tr> <tr><td></td><td></td><td></td><td>15</td><td>14</td><td></td><td></td><td>10</td><td>9</td><td></td><td></td><td>6</td><td>5</td><td>4</td><td></td><td></td></tr> </table>	72	70	68	66			63	62		59	57				53	52	51		48	47	46	44	42		40	39	38			34	33		73		32	30			26	25			22	21							15	14			10	9			6	5	4							
72	70	68	66			63	62		59	57				53																																																													
52	51		48	47	46	44	42		40	39	38			34	33																																																												
	73		32	30			26	25			22	21																																																															
			15	14			10	9			6	5	4																																																														
AVAILABLE	NOT APPLICABLE	34566-5373	G	0	C	BLUE	<table border="1"> <tr><td>72</td><td>70</td><td>68</td><td>66</td><td></td><td></td><td>63</td><td>62</td><td></td><td>59</td><td>57</td><td></td><td></td><td></td><td>53</td></tr> <tr><td>52</td><td>51</td><td></td><td>48</td><td>47</td><td>46</td><td>44</td><td>42</td><td></td><td>40</td><td>39</td><td></td><td></td><td></td><td>34</td><td>33</td></tr> <tr><td></td><td>73</td><td></td><td>32</td><td>30</td><td></td><td></td><td>26</td><td>25</td><td></td><td></td><td>22</td><td>21</td><td></td><td></td><td></td></tr> <tr><td></td><td></td><td></td><td>15</td><td>14</td><td></td><td></td><td>10</td><td>9</td><td></td><td></td><td>6</td><td></td><td></td><td></td><td></td></tr> </table>	72	70	68	66			63	62		59	57				53	52	51		48	47	46	44	42		40	39				34	33		73		32	30			26	25			22	21							15	14			10	9			6									
72	70	68	66			63	62		59	57				53																																																													
52	51		48	47	46	44	42		40	39				34	33																																																												
	73		32	30			26	25			22	21																																																															
			15	14			10	9			6																																																																

ENTER DESCRIPTION IEC NO: UAU2014-0574 DRAWN BY: SKRA JENDRANA 2013/10/08 CHKD: MVANSLAMBROU APPR: VIKOSHY 2013/10/09 REV: 00	QUALITY SYMBOLS	∇=0 ∇=0 ∇=0	GENERAL TOLERANCES (UNLESS SPECIFIED) mm INCH 4 PLACES ±--- ±--- 3 PLACES ±--- ±--- 2 PLACES ±--- ±--- 1 PLACE ±--- ±--- 0 PLACE ±--- ±--- ANGULAR ±---° DRAFT WHERE APPLICABLE MUST REMAIN WITHIN DIMENSIONS	DIMENSION STYLE MM ONLY	SCALE 1:1	DESIGN UNITS METRIC	THIRD ANGLE PROJECTION
	DRAWN BY: SKRA JENDRANA 2011/02/14		DATE: 2011/02/14		TITLE: MX123 66/73/80CKT HRNS CONN ASSY		
	CHECKED BY: MVANSLAMBROU 2011/02/14		DATE: 2011/02/14		APPROVED BY: [Signature]		
	MATERIAL NO: SEE BOM		DOCUMENT NO: SD-34566-001		SHEET NO: 60 OF 68		THIS DRAWING CONTAINS INFORMATION THAT IS PROPRIETARY TO MOLEX INCORPORATED AND SHOULD NOT BE USED WITHOUT WRITTEN PERMISSION

STATUS	GM PART #	MATERIAL #	PART/MATERIAL REVISION	WIRE DRESS OPTION	KEY OPTION P	COLOR (TPA) P	NUMBERS INDICATE CAVITIES OPEN FOR CIRCUITS P																																																																
AVAILABLE	NOT APPLICABLE	34566-5383	G	0	C	BLUE	<table border="1"> <tr><td>72</td><td>70</td><td>68</td><td>66</td><td>63</td><td>62</td><td>59</td><td>57</td><td>53</td></tr> <tr><td>52</td><td>51</td><td>48</td><td>47</td><td>46</td><td>44</td><td>42</td><td>40</td><td>39</td><td>37</td><td>36</td><td>34</td><td>33</td></tr> <tr><td colspan="2">73</td><td>32</td><td>30</td><td>26</td><td>25</td><td>24</td><td>22</td><td>21</td><td colspan="4"></td></tr> <tr><td colspan="2"></td><td>15</td><td>14</td><td colspan="2"></td><td>10</td><td>9</td><td>8</td><td>6</td><td>5</td><td>4</td><td>2</td></tr> </table>	72	70	68	66	63	62	59	57	53	52	51	48	47	46	44	42	40	39	37	36	34	33	73		32	30	26	25	24	22	21							15	14			10	9	8	6	5	4	2																
72	70	68	66	63	62	59	57	53																																																															
52	51	48	47	46	44	42	40	39	37	36	34	33																																																											
73		32	30	26	25	24	22	21																																																															
		15	14			10	9	8	6	5	4	2																																																											
AVAILABLE	NOT APPLICABLE	34566-5393	G	0	A	BLACK	<table border="1"> <tr><td></td><td>70</td><td>69</td><td></td><td></td><td>63</td><td></td><td></td><td></td><td></td><td>56</td><td>55</td><td>54</td><td>53</td></tr> <tr><td>52</td><td>51</td><td>49</td><td></td><td></td><td>44</td><td>43</td><td>42</td><td>41</td><td></td><td></td><td>36</td><td>34</td><td></td></tr> <tr><td colspan="2">73</td><td>32</td><td></td><td></td><td>28</td><td>26</td><td></td><td></td><td>23</td><td>21</td><td>19</td><td>18</td><td></td></tr> <tr><td colspan="2"></td><td>16</td><td></td><td></td><td>12</td><td>10</td><td></td><td>8</td><td></td><td>5</td><td>3</td><td></td><td></td></tr> </table>		70	69			63					56	55	54	53	52	51	49			44	43	42	41			36	34		73		32			28	26			23	21	19	18				16			12	10		8		5	3										
	70	69			63					56	55	54	53																																																										
52	51	49			44	43	42	41			36	34																																																											
73		32			28	26			23	21	19	18																																																											
		16			12	10		8		5	3																																																												
AVAILABLE	NOT APPLICABLE	34566-5413	G	0	A	BLACK	<table border="1"> <tr><td></td><td>70</td><td>69</td><td></td><td></td><td>63</td><td></td><td></td><td></td><td></td><td>56</td><td>55</td><td>54</td><td>53</td></tr> <tr><td>52</td><td>51</td><td>49</td><td></td><td></td><td>44</td><td>43</td><td>42</td><td>41</td><td></td><td></td><td>36</td><td>34</td><td></td></tr> <tr><td colspan="2">73</td><td>32</td><td></td><td></td><td>28</td><td>26</td><td></td><td></td><td>23</td><td>21</td><td>19</td><td>18</td><td></td></tr> <tr><td colspan="2"></td><td>16</td><td>15</td><td></td><td>12</td><td>10</td><td></td><td>8</td><td></td><td>5</td><td>3</td><td></td><td></td></tr> </table>		70	69			63					56	55	54	53	52	51	49			44	43	42	41			36	34		73		32			28	26			23	21	19	18				16	15		12	10		8		5	3										
	70	69			63					56	55	54	53																																																										
52	51	49			44	43	42	41			36	34																																																											
73		32			28	26			23	21	19	18																																																											
		16	15		12	10		8		5	3																																																												
AVAILABLE	NOT APPLICABLE	34566-5423	G	0	A	BLACK	<table border="1"> <tr><td></td><td>70</td><td>69</td><td></td><td></td><td>63</td><td></td><td></td><td></td><td></td><td>58</td><td>56</td><td>55</td><td>54</td><td>53</td></tr> <tr><td>52</td><td>51</td><td>49</td><td></td><td></td><td>44</td><td>43</td><td>42</td><td>41</td><td></td><td></td><td>36</td><td>34</td><td></td><td></td></tr> <tr><td colspan="2">73</td><td>32</td><td></td><td></td><td>28</td><td>26</td><td></td><td></td><td></td><td></td><td></td><td>19</td><td>18</td><td></td></tr> <tr><td colspan="2"></td><td>16</td><td></td><td></td><td>12</td><td>10</td><td></td><td></td><td></td><td></td><td></td><td>3</td><td></td><td></td></tr> </table>		70	69			63					58	56	55	54	53	52	51	49			44	43	42	41			36	34			73		32			28	26						19	18				16			12	10						3						
	70	69			63					58	56	55	54	53																																																									
52	51	49			44	43	42	41			36	34																																																											
73		32			28	26						19	18																																																										
		16			12	10						3																																																											
AVAILABLE	NOT APPLICABLE	34566-5433	G	9	B	ST.GRAY	<table border="1"> <tr><td></td><td></td><td>68</td><td>67</td><td></td><td>64</td><td></td><td></td><td></td><td>59</td><td>58</td><td></td><td></td><td>54</td><td></td></tr> <tr><td></td><td></td><td></td><td>46</td><td>45</td><td></td><td></td><td></td><td></td><td>39</td><td>38</td><td></td><td></td><td></td><td></td></tr> <tr><td colspan="2">73</td><td>32</td><td>30</td><td>29</td><td>28</td><td>27</td><td></td><td></td><td>23</td><td>22</td><td></td><td></td><td>17</td><td>1</td></tr> <tr><td colspan="2"></td><td></td><td></td><td></td><td></td><td></td><td>10</td><td></td><td>6</td><td></td><td></td><td></td><td></td><td></td></tr> </table>			68	67		64				59	58			54					46	45					39	38					73		32	30	29	28	27			23	22			17	1								10		6									
		68	67		64				59	58			54																																																										
			46	45					39	38																																																													
73		32	30	29	28	27			23	22			17	1																																																									
							10		6																																																														
AVAILABLE	NOT APPLICABLE	34566-5443	G	9	B	ST.GRAY	<table border="1"> <tr><td></td><td></td><td>68</td><td>67</td><td></td><td>64</td><td></td><td></td><td></td><td>59</td><td>58</td><td></td><td></td><td>54</td><td></td></tr> <tr><td></td><td></td><td></td><td>46</td><td>45</td><td></td><td></td><td></td><td></td><td>39</td><td>38</td><td></td><td></td><td></td><td></td></tr> <tr><td colspan="2">73</td><td>32</td><td>30</td><td>29</td><td>28</td><td>27</td><td></td><td></td><td>23</td><td>22</td><td></td><td></td><td>17</td><td>1</td></tr> <tr><td colspan="2"></td><td></td><td>15</td><td>13</td><td></td><td></td><td>10</td><td></td><td>6</td><td></td><td></td><td></td><td></td><td></td></tr> </table>			68	67		64				59	58			54					46	45					39	38					73		32	30	29	28	27			23	22			17	1				15	13			10		6									
		68	67		64				59	58			54																																																										
			46	45					39	38																																																													
73		32	30	29	28	27			23	22			17	1																																																									
			15	13			10		6																																																														
AVAILABLE	NOT APPLICABLE	34566-5453	G	0	B	ST.GRAY	<table border="1"> <tr><td></td><td></td><td>68</td><td>67</td><td></td><td>64</td><td></td><td></td><td></td><td>59</td><td>58</td><td></td><td></td><td>54</td><td></td></tr> <tr><td></td><td></td><td></td><td>46</td><td>45</td><td></td><td></td><td></td><td></td><td>39</td><td>38</td><td></td><td></td><td></td><td></td></tr> <tr><td colspan="2">73</td><td>32</td><td>30</td><td>29</td><td>28</td><td>27</td><td></td><td></td><td>23</td><td>22</td><td></td><td></td><td>17</td><td>1</td></tr> <tr><td colspan="2"></td><td></td><td>15</td><td>13</td><td></td><td></td><td>10</td><td></td><td>6</td><td></td><td></td><td></td><td></td><td></td></tr> </table>			68	67		64				59	58			54					46	45					39	38					73		32	30	29	28	27			23	22			17	1				15	13			10		6									
		68	67		64				59	58			54																																																										
			46	45					39	38																																																													
73		32	30	29	28	27			23	22			17	1																																																									
			15	13			10		6																																																														
AVAILABLE	NOT APPLICABLE	34566-5463	G	0	A	BLACK	<table border="1"> <tr><td>72</td><td>70</td><td></td><td></td><td></td><td>63</td><td></td><td></td><td></td><td></td><td></td><td></td><td></td><td></td><td></td></tr> <tr><td>52</td><td></td><td>49</td><td></td><td></td><td></td><td></td><td></td><td>41</td><td></td><td></td><td></td><td></td><td></td><td></td></tr> <tr><td colspan="2">73</td><td></td><td>31</td><td>30</td><td>28</td><td>27</td><td>26</td><td></td><td>23</td><td></td><td>20</td><td>19</td><td></td><td></td></tr> <tr><td colspan="2"></td><td></td><td>16</td><td>15</td><td>14</td><td>12</td><td>10</td><td></td><td></td><td>6</td><td></td><td></td><td></td><td></td></tr> </table>	72	70				63										52		49						41							73			31	30	28	27	26		23		20	19						16	15	14	12	10			6								
72	70				63																																																																		
52		49						41																																																															
73			31	30	28	27	26		23		20	19																																																											
			16	15	14	12	10			6																																																													
AVAILABLE	NOT APPLICABLE	34566-5473	G	0	A	BLACK	<table border="1"> <tr><td>72</td><td>71</td><td>70</td><td>68</td><td>67</td><td>66</td><td>65</td><td>64</td><td>63</td><td>62</td><td>60</td><td>59</td><td></td><td>56</td><td></td><td>53</td></tr> <tr><td>52</td><td>51</td><td></td><td>48</td><td>47</td><td>46</td><td>45</td><td>44</td><td>43</td><td>42</td><td>41</td><td>40</td><td></td><td></td><td></td><td></td></tr> <tr><td colspan="2">73</td><td></td><td>31</td><td>30</td><td>29</td><td>28</td><td>27</td><td>26</td><td>25</td><td>24</td><td>23</td><td></td><td>20</td><td>19</td><td>17</td></tr> <tr><td colspan="2"></td><td></td><td>16</td><td>15</td><td>14</td><td>12</td><td>11</td><td>10</td><td></td><td></td><td>6</td><td></td><td></td><td></td><td></td></tr> </table>	72	71	70	68	67	66	65	64	63	62	60	59		56		53	52	51		48	47	46	45	44	43	42	41	40					73			31	30	29	28	27	26	25	24	23		20	19	17				16	15	14	12	11	10			6				
72	71	70	68	67	66	65	64	63	62	60	59		56		53																																																								
52	51		48	47	46	45	44	43	42	41	40																																																												
73			31	30	29	28	27	26	25	24	23		20	19	17																																																								
			16	15	14	12	11	10			6																																																												

ENTER DESCRIPTION IEC NO. UAU2014-0574 DRAWNS: SKRAJENDRANA 2013/10/08 CHKD: APPR: VKOSHY 2013/10/09 REV: DESCRIPTION	QUALITY SYMBOLS	GENERAL TOLERANCES (UNLESS SPECIFIED)	DIMENSION STYLE	SCALE	DESIGN UNITS	THIRD ANGLE PROJECTION
	▽=0	mm INCH	MM ONLY	1:1	METRIC	
	▽=0	4 PLACES ±--- ±---	DRAWN BY DATE	TITLE		
	▽=0	3 PLACES ±--- ±---	SKRAJENDRANA 2011/02/14	MX123 66/73/80CKT HRNS CONN ASSY		
▽=0	2 PLACES ±--- ±---	CHECKED BY DATE	APPROVED BY DATE			
▽=0	1 PLACE ±--- ±---	MVANS LAMBROU 2011/02/14				
▽=0	0 PLACE ±--- ±---					
	ANGULAR ±---°	DRAFT WHERE APPLICABLE MUST REMAIN WITHIN DIMENSIONS	MATERIAL NO.	DOCUMENT NO.	SHEET NO.	
			SEE BOM TABLE	SD-34566-001	61 OF 68	
			THIS DRAWING CONTAINS INFORMATION THAT IS PROPRIETARY TO MOLEX INCORPORATED AND SHOULD NOT BE USED WITHOUT WRITTEN PERMISSION			

STATUS	GM PART #	MATERIAL #	PART/MATERIAL REVISION	WIRE DRESS OPTION	KEY OPTION P	COLOR (TPA) P	NUMBERS INDICATE CAVITIES OPEN FOR CIRCUITS P																																																																		
AVAILABLE	NOT APPLICABLE	34566-5483	G	0	B	ST.GRAY	<table border="1"> <tr><td>72</td><td>70</td><td>68</td><td>66</td><td>64</td><td>63</td><td></td><td>60</td><td>59</td><td></td><td>55</td><td>54</td><td>53</td></tr> <tr><td>52</td><td>50</td><td>48</td><td>46</td><td></td><td></td><td></td><td>40</td><td>39</td><td></td><td>35</td><td>34</td><td>33</td></tr> <tr><td>73</td><td></td><td>32</td><td>31</td><td>30</td><td>29</td><td>28</td><td>27</td><td>26</td><td>25</td><td>24</td><td></td><td>20</td><td>17</td></tr> <tr><td></td><td></td><td>16</td><td></td><td></td><td></td><td></td><td></td><td>10</td><td>8</td><td></td><td>5</td><td>4</td><td>2</td><td>1</td></tr> </table>	72	70	68	66	64	63		60	59		55	54	53	52	50	48	46				40	39		35	34	33	73		32	31	30	29	28	27	26	25	24		20	17			16						10	8		5	4	2	1											
72	70	68	66	64	63		60	59		55	54	53																																																													
52	50	48	46				40	39		35	34	33																																																													
73		32	31	30	29	28	27	26	25	24		20	17																																																												
		16						10	8		5	4	2	1																																																											
AVAILABLE	NOT APPLICABLE	34566-5493	G	0	A	BLACK	<table border="1"> <tr><td>72</td><td>70</td><td>69</td><td></td><td></td><td>63</td><td></td><td>60</td><td>59</td><td>58</td><td>57</td><td>56</td><td>55</td><td>54</td><td>53</td></tr> <tr><td>52</td><td>51</td><td>49</td><td></td><td></td><td>44</td><td>43</td><td>42</td><td>41</td><td>40</td><td></td><td>37</td><td>36</td><td></td><td>34</td></tr> <tr><td>73</td><td></td><td>32</td><td></td><td></td><td>28</td><td>26</td><td>24</td><td></td><td></td><td></td><td></td><td>19</td><td>18</td><td>17</td></tr> <tr><td></td><td></td><td>16</td><td>15</td><td></td><td>12</td><td>10</td><td></td><td></td><td></td><td></td><td></td><td>3</td><td>2</td><td>1</td></tr> </table>	72	70	69			63		60	59	58	57	56	55	54	53	52	51	49			44	43	42	41	40		37	36		34	73		32			28	26	24					19	18	17			16	15		12	10						3	2	1						
72	70	69			63		60	59	58	57	56	55	54	53																																																											
52	51	49			44	43	42	41	40		37	36		34																																																											
73		32			28	26	24					19	18	17																																																											
		16	15		12	10						3	2	1																																																											
AVAILABLE	NOT APPLICABLE	34566-5513	G	9	B	ST.GRAY	<table border="1"> <tr><td></td><td></td><td>68</td><td>67</td><td></td><td>64</td><td>63</td><td></td><td></td><td></td><td>58</td><td></td><td>55</td><td></td><td></td></tr> <tr><td></td><td></td><td></td><td>46</td><td>45</td><td></td><td>43</td><td></td><td></td><td></td><td>38</td><td></td><td>35</td><td></td><td></td></tr> <tr><td>73</td><td></td><td>32</td><td>30</td><td>29</td><td>28</td><td>27</td><td></td><td></td><td></td><td>22</td><td></td><td>19</td><td></td><td>17</td></tr> <tr><td></td><td></td><td></td><td></td><td></td><td></td><td></td><td>10</td><td></td><td></td><td></td><td></td><td></td><td></td><td>1</td></tr> </table>			68	67		64	63				58		55						46	45		43				38		35			73		32	30	29	28	27				22		19		17								10							1						
		68	67		64	63				58		55																																																													
			46	45		43				38		35																																																													
73		32	30	29	28	27				22		19		17																																																											
							10							1																																																											
AVAILABLE	NOT APPLICABLE	34566-5523	G	9	A	BLACK	<table border="1"> <tr><td>72</td><td></td><td>69</td><td>67</td><td>66</td><td>65</td><td>63</td><td></td><td>60</td><td></td><td>57</td><td>56</td><td></td><td>53</td></tr> <tr><td></td><td></td><td>49</td><td>47</td><td></td><td>44</td><td>43</td><td>42</td><td>40</td><td></td><td>37</td><td>36</td><td>35</td><td>33</td></tr> <tr><td>73</td><td></td><td>31</td><td>30</td><td>29</td><td>28</td><td>27</td><td>26</td><td>24</td><td></td><td>21</td><td>20</td><td></td><td>17</td></tr> <tr><td></td><td></td><td>16</td><td>15</td><td>14</td><td>13</td><td>11</td><td>10</td><td></td><td></td><td>5</td><td>4</td><td>3</td><td>2</td><td>1</td></tr> </table>	72		69	67	66	65	63		60		57	56		53			49	47		44	43	42	40		37	36	35	33	73		31	30	29	28	27	26	24		21	20		17			16	15	14	13	11	10			5	4	3	2	1									
72		69	67	66	65	63		60		57	56		53																																																												
		49	47		44	43	42	40		37	36	35	33																																																												
73		31	30	29	28	27	26	24		21	20		17																																																												
		16	15	14	13	11	10			5	4	3	2	1																																																											
AVAILABLE	NOT APPLICABLE	34566-5533	G	9	B	ST.GRAY	<table border="1"> <tr><td></td><td></td><td>68</td><td>67</td><td></td><td>64</td><td></td><td></td><td></td><td>59</td><td>58</td><td></td><td></td><td>54</td></tr> <tr><td></td><td></td><td></td><td>46</td><td>45</td><td></td><td></td><td></td><td></td><td>39</td><td>38</td><td></td><td></td><td></td></tr> <tr><td>73</td><td></td><td>32</td><td>30</td><td>29</td><td>28</td><td>27</td><td></td><td></td><td>23</td><td>22</td><td></td><td></td><td>17</td></tr> <tr><td></td><td></td><td></td><td></td><td></td><td></td><td></td><td>10</td><td>9</td><td>8</td><td>6</td><td></td><td></td><td></td><td>1</td></tr> </table>			68	67		64				59	58			54				46	45					39	38				73		32	30	29	28	27			23	22			17								10	9	8	6				1									
		68	67		64				59	58			54																																																												
			46	45					39	38																																																															
73		32	30	29	28	27			23	22			17																																																												
							10	9	8	6				1																																																											
AVAILABLE	NOT APPLICABLE	34566-5543	G	9	A	BLACK	<table border="1"> <tr><td></td><td></td><td>68</td><td>67</td><td></td><td>64</td><td></td><td></td><td></td><td>59</td><td>58</td><td></td><td></td><td>54</td></tr> <tr><td></td><td></td><td></td><td>46</td><td>45</td><td></td><td></td><td></td><td></td><td>39</td><td>38</td><td></td><td></td><td></td></tr> <tr><td>73</td><td></td><td>32</td><td>30</td><td>29</td><td>28</td><td>27</td><td></td><td></td><td>23</td><td>22</td><td></td><td></td><td>17</td></tr> <tr><td></td><td></td><td></td><td></td><td></td><td></td><td>12</td><td>10</td><td>8</td><td>6</td><td></td><td></td><td></td><td></td><td>1</td></tr> </table>			68	67		64				59	58			54				46	45					39	38				73		32	30	29	28	27			23	22			17							12	10	8	6					1									
		68	67		64				59	58			54																																																												
			46	45					39	38																																																															
73		32	30	29	28	27			23	22			17																																																												
						12	10	8	6					1																																																											
AVAILABLE	NOT APPLICABLE	34566-5553	G	9	B	ST.GRAY	<table border="1"> <tr><td></td><td></td><td>68</td><td>67</td><td></td><td>64</td><td></td><td></td><td></td><td>59</td><td>58</td><td></td><td></td><td>54</td></tr> <tr><td></td><td></td><td></td><td>46</td><td>45</td><td></td><td></td><td></td><td></td><td>39</td><td>38</td><td></td><td></td><td></td></tr> <tr><td>73</td><td></td><td>32</td><td>30</td><td>29</td><td>28</td><td>27</td><td></td><td></td><td>23</td><td>22</td><td></td><td></td><td>17</td></tr> <tr><td></td><td></td><td></td><td></td><td></td><td></td><td>12</td><td>10</td><td>8</td><td>6</td><td></td><td></td><td></td><td></td><td>1</td></tr> </table>			68	67		64				59	58			54				46	45					39	38				73		32	30	29	28	27			23	22			17							12	10	8	6					1									
		68	67		64				59	58			54																																																												
			46	45					39	38																																																															
73		32	30	29	28	27			23	22			17																																																												
						12	10	8	6					1																																																											
AVAILABLE	NOT APPLICABLE	34566-5563	G	0	A	BLACK	<table border="1"> <tr><td>72</td><td>71</td><td>70</td><td>69</td><td></td><td></td><td>64</td><td>63</td><td></td><td>60</td><td>59</td><td>58</td><td>57</td><td>56</td><td>55</td><td>54</td><td>53</td></tr> <tr><td>52</td><td>51</td><td>49</td><td>48</td><td>47</td><td></td><td>45</td><td>44</td><td>43</td><td>42</td><td>41</td><td></td><td>37</td><td>36</td><td></td><td>34</td><td>33</td></tr> <tr><td>73</td><td></td><td>32</td><td></td><td>30</td><td></td><td>28</td><td>26</td><td></td><td></td><td></td><td></td><td></td><td>19</td><td>18</td><td>17</td></tr> <tr><td></td><td></td><td>16</td><td>15</td><td></td><td></td><td>12</td><td>10</td><td></td><td></td><td></td><td></td><td></td><td>3</td><td>2</td><td>1</td></tr> </table>	72	71	70	69			64	63		60	59	58	57	56	55	54	53	52	51	49	48	47		45	44	43	42	41		37	36		34	33	73		32		30		28	26						19	18	17			16	15			12	10						3	2	1
72	71	70	69			64	63		60	59	58	57	56	55	54	53																																																									
52	51	49	48	47		45	44	43	42	41		37	36		34	33																																																									
73		32		30		28	26						19	18	17																																																										
		16	15			12	10						3	2	1																																																										
AVAILABLE	NOT APPLICABLE	34566-5573	G	0	C	BLUE	<table border="1"> <tr><td>72</td><td>70</td><td>68</td><td>66</td><td></td><td>63</td><td>62</td><td></td><td>59</td><td>58</td><td>57</td><td>56</td><td>55</td><td>53</td></tr> <tr><td>52</td><td>51</td><td>49</td><td>48</td><td>47</td><td>46</td><td>44</td><td>42</td><td>40</td><td>39</td><td>38</td><td>37</td><td>36</td><td>34</td><td>33</td></tr> <tr><td>73</td><td></td><td>32</td><td></td><td>30</td><td></td><td>26</td><td>25</td><td>24</td><td>23</td><td>22</td><td>21</td><td>20</td><td>19</td><td>18</td><td>17</td></tr> <tr><td></td><td></td><td></td><td>15</td><td>14</td><td>13</td><td></td><td>10</td><td>9</td><td>8</td><td>7</td><td>6</td><td>5</td><td>4</td><td>2</td><td>1</td></tr> </table>	72	70	68	66		63	62		59	58	57	56	55	53	52	51	49	48	47	46	44	42	40	39	38	37	36	34	33	73		32		30		26	25	24	23	22	21	20	19	18	17				15	14	13		10	9	8	7	6	5	4	2	1					
72	70	68	66		63	62		59	58	57	56	55	53																																																												
52	51	49	48	47	46	44	42	40	39	38	37	36	34	33																																																											
73		32		30		26	25	24	23	22	21	20	19	18	17																																																										
			15	14	13		10	9	8	7	6	5	4	2	1																																																										

ENTER DESCRIPTION IEC NO: UAU2014-0574 DRAWNS: SKRAJENDRANA 2013/10/08 CHKD: CHYK APPR: VIKOSHY 2013/10/09	QUALITY SYMBOLS ∇=0 ∇=0 ∇=0	GENERAL TOLERANCES (UNLESS SPECIFIED) <table border="1"> <tr><th></th><th>mm</th><th>INCH</th></tr> <tr><td>4 PLACES</td><td>±---</td><td>±---</td></tr> <tr><td>3 PLACES</td><td>±---</td><td>±---</td></tr> <tr><td>2 PLACES</td><td>±---</td><td>±---</td></tr> <tr><td>1 PLACE</td><td>±---</td><td>±---</td></tr> <tr><td>0 PLACE</td><td>±---</td><td>±---</td></tr> </table>		mm	INCH	4 PLACES	±---	±---	3 PLACES	±---	±---	2 PLACES	±---	±---	1 PLACE	±---	±---	0 PLACE	±---	±---	DIMENSION STYLE MM ONLY	SCALE 1:1	DESIGN UNITS METRIC	THIRD ANGLE PROJECTION
		mm	INCH																					
	4 PLACES	±---	±---																					
	3 PLACES	±---	±---																					
2 PLACES	±---	±---																						
1 PLACE	±---	±---																						
0 PLACE	±---	±---																						
DRAWN BY: SKRAJENDRANA 2011/02/14 CHECKED BY: MYANSLAMBROU 2011/02/14 APPROVED BY:	DATE:	TITLE:	MATERIAL NO.:	DOCUMENT NO.:	SHEET NO.:	SIZE:																		
ANGULAR ±--- DRAFT WHERE APPLICABLE MUST REMAIN WITHIN DIMENSIONS	SEE BOM TABLE	THIS DRAWING CONTAINS INFORMATION THAT IS PROPRIETARY TO MOLEX INCORPORATED AND SHOULD NOT BE USED WITHOUT WRITTEN PERMISSION	MX123 66/73/80CKT HRNS CONN ASSY molex	SD-34566-001	62 OF 68	D																		
GO																								

STATUS	GM PART #	MATERIAL #	PART/MATERIAL REVISION	WIRE DRESS OPTION	KEY OPTION Fp	COLOR (TPA) Fp	NUMBERS INDICATE CAVITIES OPEN FOR CIRCUITS Fp																																																													
AVAILABLE	NOT APPLICABLE	34566-5583	G	0	B	ST.GRAY	72	70	68	66	64	63	60	59	55	54	53	52	51	48	46	44	42	40	39	37	36	34	33	32	31	30	29	28	27	26	25	24	23	22	21	20	19	18	17	16	15	14	13	12	11	10	9	8	7	6	5	4	3	2	1							
AVAILABLE	NOT APPLICABLE	34566-5593	G	0	C	BLUE	72	70	68	66	64	63	62	61	59	57	55	54	53	52	51	48	47	46	44	42	40	39	37	36	34	33	32	31	30	29	28	27	26	25	24	23	22	21	20	19	18	17	16	15	14	13	12	11	10	9	8	7	6	5	4	3	2	1				
AVAILABLE	NOT APPLICABLE	34566-5613	G	0	C	BLUE	72	70	68	66	64	63	62	61	59	58	57	55	54	53	52	51	48	47	46	44	42	40	39	37	36	34	33	32	31	30	29	28	27	26	25	24	23	22	21	20	19	18	17	16	15	14	13	12	11	10	9	8	7	6	5	4	3	2	1			
AVAILABLE	NOT APPLICABLE	34566-5623	G	0	C	BLUE	72	70	68	66	64	63	62	61	59	57	55	54	53	52	51	48	47	46	44	42	40	39	37	36	34	33	32	31	30	29	28	27	26	25	24	23	22	21	20	19	18	17	16	15	14	13	12	11	10	9	8	7	6	5	4	3	2	1				
AVAILABLE	NOT APPLICABLE	34566-5633	G	0	B	ST.GRAY	72	70	68	66	64	63	62	61	60	59	57	55	54	53	52	51	48	46	44	43	41	40	37	36	34	33	32	31	30	29	28	27	26	25	24	23	22	21	20	19	18	17	16	15	14	13	12	11	10	9	8	7	6	5	4	3	2	1				
AVAILABLE	NOT APPLICABLE	34566-5643	G	0	B	ST.GRAY	72	70	68	66	64	63	62	61	60	59	57	55	54	53	52	51	48	46	44	43	41	40	37	36	34	33	32	31	30	29	28	27	26	25	24	23	22	21	20	19	18	17	16	15	14	13	12	11	10	9	8	7	6	5	4	3	2	1				
AVAILABLE	NOT APPLICABLE	34566-5653	G	0	A	BLACK	72	71	70	69	68	66	65	64	63	61	60	57	56	54	53	52	51	50	49	48	46	45	44	43	42	40	39	38	37	36	34	33	32	31	30	29	28	26	25	23	22	21	20	19	18	17	16	15	14	13	12	11	10	9	8	7	6	5	4	3	2	1
AVAILABLE	NOT APPLICABLE	34566-5663	G	0	C	BLUE	72	70	69	67	66	64	62	60	57	55	54	53	52	51	50	48	46	45	44	42	40	37	35	34	33	32	31	30	29	28	27	26	25	24	23	22	21	20	19	18	17	16	15	14	13	12	11	10	9	8	7	6	5	4	3	2	1					
AVAILABLE	NOT APPLICABLE	34566-5673	G	0	C	BLUE	72	70	69	67	66	64	62	60	57	55	54	53	52	51	50	49	48	46	45	44	42	40	37	35	34	33	32	31	30	29	28	27	26	25	24	23	22	21	20	19	18	17	16	15	14	13	12	11	10	9	8	7	6	5	4	3	2	1				

ENTER DESCRIPTION IEC NO. UAU2014-0574 DRAWNS: SKRAJENDRANA 2013/10/08 CHKD: CHYKZ APPR: VIOSHY 2013/10/09 REV: 00	QUALITY SYMBOLS ∇=0 ∇=0 ∇=0	GENERAL TOLERANCES (UNLESS SPECIFIED) mm INCH 4 PLACES ±--- ±--- 3 PLACES ±--- ±--- 2 PLACES ±--- ±--- 1 PLACE ±--- ±--- 0 PLACE ±--- ±--- ANGULAR ±--- DRAFT WHERE APPLICABLE MUST REMAIN WITHIN DIMENSIONS	DIMENSION STYLE MM ONLY	SCALE 1:1	DESIGN UNITS METRIC	THIRD ANGLE PROJECTION
	DRAWN BY: SKRAJENDRANA 2011/02/14 CHECKED BY: MVANSLAMBROU 2011/02/14 APPROVED BY:		MATERIAL NO. SD-34566-001 DOCUMENT NO.		SHEET NO. 63 OF 68	
	TITLE MX123 66/73/80CKT HRNS CONN ASSY		SEE BOM TABLE		THIS DRAWING CONTAINS INFORMATION THAT IS PROPRIETARY TO MOLEX INCORPORATED AND SHOULD NOT BE USED WITHOUT WRITTEN PERMISSION	
	MOLEX					

STATUS	GM PART #	MATERIAL #	PART/MATERIAL REVISION	WIRE DRESS OPTION	KEY OPTION P	COLOR (TPA) P	NUMBERS INDICATE CAVITIES OPEN FOR CIRCUITS P																																																																							
AVAILABLE	NOT APPLICABLE	34566-5783	G	0	C	BLUE	<table border="1"> <tr><td>72</td><td>70</td><td>68</td><td></td><td></td><td></td><td>63</td><td>62</td><td></td><td>59</td><td>57</td><td></td><td>53</td></tr> <tr><td>52</td><td>51</td><td>48</td><td>47</td><td></td><td>44</td><td>42</td><td>40</td><td>39</td><td>37</td><td>36</td><td></td><td>34</td><td>33</td></tr> <tr><td colspan="2">73</td><td>32</td><td>30</td><td></td><td>27</td><td>26</td><td>25</td><td>24</td><td>22</td><td>21</td><td>20</td><td></td><td></td></tr> <tr><td colspan="2"></td><td>15</td><td>14</td><td>13</td><td></td><td></td><td></td><td>8</td><td>6</td><td>5</td><td>4</td><td></td><td>2</td></tr> </table>	72	70	68				63	62		59	57		53	52	51	48	47		44	42	40	39	37	36		34	33	73		32	30		27	26	25	24	22	21	20					15	14	13				8	6	5	4		2																
72	70	68				63	62		59	57		53																																																																		
52	51	48	47		44	42	40	39	37	36		34	33																																																																	
73		32	30		27	26	25	24	22	21	20																																																																			
		15	14	13				8	6	5	4		2																																																																	
AVAILABLE	NOT APPLICABLE	34566-5793	G	0	B	ST.GRAY	<table border="1"> <tr><td>72</td><td>70</td><td>68</td><td>66</td><td></td><td></td><td></td><td></td><td>60</td><td>59</td><td></td><td></td><td>55</td><td>54</td><td>53</td></tr> <tr><td>52</td><td>50</td><td>48</td><td>46</td><td></td><td></td><td></td><td></td><td>40</td><td>39</td><td></td><td></td><td>35</td><td>34</td><td>33</td></tr> <tr><td colspan="2">73</td><td>32</td><td>31</td><td>30</td><td>29</td><td>28</td><td>27</td><td>26</td><td>25</td><td>24</td><td></td><td></td><td></td><td>17</td></tr> <tr><td colspan="2"></td><td>16</td><td></td><td></td><td></td><td></td><td></td><td>10</td><td>8</td><td></td><td></td><td></td><td></td><td>2</td><td>1</td></tr> </table>	72	70	68	66					60	59			55	54	53	52	50	48	46					40	39			35	34	33	73		32	31	30	29	28	27	26	25	24				17			16						10	8					2	1										
72	70	68	66					60	59			55	54	53																																																																
52	50	48	46					40	39			35	34	33																																																																
73		32	31	30	29	28	27	26	25	24				17																																																																
		16						10	8					2	1																																																															
AVAILABLE	NOT APPLICABLE	34566-5813	G	0	B	ST.GRAY	<table border="1"> <tr><td>72</td><td>70</td><td>68</td><td>66</td><td></td><td></td><td></td><td></td><td>60</td><td>59</td><td></td><td></td><td>55</td><td>54</td><td>53</td></tr> <tr><td>52</td><td>50</td><td>48</td><td>46</td><td></td><td></td><td></td><td></td><td>40</td><td>39</td><td></td><td></td><td>35</td><td>34</td><td>33</td></tr> <tr><td colspan="2">73</td><td>32</td><td>31</td><td>30</td><td>29</td><td>28</td><td>27</td><td>26</td><td>25</td><td>24</td><td>23</td><td></td><td>19</td><td>18</td><td>17</td></tr> <tr><td colspan="2"></td><td>16</td><td></td><td></td><td></td><td></td><td></td><td>10</td><td>8</td><td>7</td><td></td><td></td><td></td><td>2</td><td>1</td></tr> </table>	72	70	68	66					60	59			55	54	53	52	50	48	46					40	39			35	34	33	73		32	31	30	29	28	27	26	25	24	23		19	18	17			16						10	8	7				2	1									
72	70	68	66					60	59			55	54	53																																																																
52	50	48	46					40	39			35	34	33																																																																
73		32	31	30	29	28	27	26	25	24	23		19	18	17																																																															
		16						10	8	7				2	1																																																															
AVAILABLE	NOT APPLICABLE	34566-5823	G	0	A	BLACK	<table border="1"> <tr><td>72</td><td>70</td><td></td><td></td><td></td><td></td><td>63</td><td></td><td></td><td></td><td></td><td></td><td></td><td></td><td></td><td></td></tr> <tr><td>52</td><td></td><td>49</td><td></td><td></td><td></td><td>43</td><td>41</td><td></td><td></td><td></td><td></td><td></td><td></td><td></td><td></td></tr> <tr><td colspan="2">73</td><td></td><td>31</td><td>30</td><td>28</td><td>27</td><td>26</td><td></td><td>23</td><td></td><td></td><td>20</td><td>19</td><td></td><td></td></tr> <tr><td colspan="2"></td><td></td><td>16</td><td>15</td><td>14</td><td></td><td></td><td>10</td><td></td><td></td><td>6</td><td></td><td></td><td></td><td></td></tr> </table>	72	70					63										52		49				43	41									73			31	30	28	27	26		23			20	19						16	15	14			10			6											
72	70					63																																																																								
52		49				43	41																																																																							
73			31	30	28	27	26		23			20	19																																																																	
			16	15	14			10			6																																																																			
AVAILABLE	NOT APPLICABLE	34566-5833	G	0	A	BLACK	<table border="1"> <tr><td>72</td><td>70</td><td></td><td></td><td></td><td></td><td>63</td><td></td><td></td><td></td><td></td><td></td><td></td><td></td><td></td><td></td></tr> <tr><td>52</td><td></td><td>49</td><td></td><td></td><td></td><td>43</td><td>41</td><td></td><td></td><td></td><td></td><td></td><td></td><td></td><td></td></tr> <tr><td colspan="2">73</td><td></td><td>31</td><td>30</td><td>28</td><td>27</td><td>26</td><td></td><td>23</td><td></td><td></td><td>20</td><td>19</td><td></td><td></td></tr> <tr><td colspan="2"></td><td></td><td>16</td><td>15</td><td>14</td><td></td><td></td><td>12</td><td>10</td><td></td><td></td><td>6</td><td></td><td></td><td></td></tr> </table>	72	70					63										52		49				43	41									73			31	30	28	27	26		23			20	19						16	15	14			12	10			6										
72	70					63																																																																								
52		49				43	41																																																																							
73			31	30	28	27	26		23			20	19																																																																	
			16	15	14			12	10			6																																																																		
AVAILABLE	NOT APPLICABLE	34566-5843	G	0	H	ST.GRAY	<table border="1"> <tr><td>79</td><td></td><td></td><td></td><td>74</td><td>73</td><td>72</td><td>71</td><td></td><td>68</td><td>67</td><td></td><td>65</td><td>64</td><td>63</td><td>62</td><td>61</td></tr> <tr><td>59</td><td></td><td>57</td><td></td><td>54</td><td>52</td><td></td><td></td><td></td><td></td><td></td><td></td><td></td><td></td><td></td><td>42</td><td>41</td></tr> <tr><td colspan="2">73</td><td>38</td><td></td><td>34</td><td>33</td><td></td><td></td><td>29</td><td>27</td><td>25</td><td></td><td></td><td></td><td></td><td></td><td></td></tr> <tr><td colspan="2"></td><td>18</td><td></td><td>15</td><td>14</td><td></td><td></td><td>11</td><td>10</td><td>9</td><td>8</td><td>7</td><td></td><td></td><td></td><td></td></tr> </table>	79				74	73	72	71		68	67		65	64	63	62	61	59		57		54	52										42	41	73		38		34	33			29	27	25									18		15	14			11	10	9	8	7							
79				74	73	72	71		68	67		65	64	63	62	61																																																														
59		57		54	52										42	41																																																														
73		38		34	33			29	27	25																																																																				
		18		15	14			11	10	9	8	7																																																																		
AVAILABLE	NOT APPLICABLE	34566-5853	G	0	H	ST.GRAY	<table border="1"> <tr><td>79</td><td></td><td></td><td></td><td>74</td><td>73</td><td>72</td><td>71</td><td></td><td>68</td><td>67</td><td></td><td>65</td><td>64</td><td>63</td><td>62</td><td>61</td></tr> <tr><td>59</td><td></td><td>57</td><td></td><td>54</td><td>52</td><td></td><td></td><td></td><td></td><td></td><td></td><td></td><td></td><td></td><td>43</td><td>42</td><td>41</td></tr> <tr><td colspan="2">73</td><td>38</td><td></td><td>33</td><td></td><td></td><td></td><td>29</td><td>27</td><td>25</td><td></td><td></td><td></td><td></td><td></td><td></td><td></td></tr> <tr><td colspan="2"></td><td>18</td><td></td><td>15</td><td>14</td><td></td><td></td><td>11</td><td>10</td><td>9</td><td>8</td><td>7</td><td></td><td></td><td></td><td></td><td></td></tr> </table>	79				74	73	72	71		68	67		65	64	63	62	61	59		57		54	52										43	42	41	73		38		33				29	27	25										18		15	14			11	10	9	8	7					
79				74	73	72	71		68	67		65	64	63	62	61																																																														
59		57		54	52										43	42	41																																																													
73		38		33				29	27	25																																																																				
		18		15	14			11	10	9	8	7																																																																		
AVAILABLE	NOT APPLICABLE	34566-5863	G	0	C	BLUE	<table border="1"> <tr><td>72</td><td>70</td><td></td><td></td><td>66</td><td></td><td>63</td><td>62</td><td></td><td>59</td><td>57</td><td>56</td><td>55</td><td>53</td></tr> <tr><td>52</td><td>51</td><td></td><td></td><td>46</td><td>44</td><td>42</td><td>40</td><td>39</td><td>37</td><td>36</td><td></td><td>34</td><td>33</td></tr> <tr><td colspan="2">73</td><td>32</td><td>30</td><td></td><td></td><td>26</td><td>25</td><td></td><td>22</td><td>21</td><td>19</td><td>18</td><td></td></tr> <tr><td colspan="2"></td><td>15</td><td>14</td><td></td><td></td><td></td><td>10</td><td>9</td><td></td><td>6</td><td></td><td>3</td><td></td></tr> </table>	72	70			66		63	62		59	57	56	55	53	52	51			46	44	42	40	39	37	36		34	33	73		32	30			26	25		22	21	19	18				15	14				10	9		6		3																
72	70			66		63	62		59	57	56	55	53																																																																	
52	51			46	44	42	40	39	37	36		34	33																																																																	
73		32	30			26	25		22	21	19	18																																																																		
		15	14				10	9		6		3																																																																		
AVAILABLE	NOT APPLICABLE	34566-5873	G	0	B	ST.GRAY	<table border="1"> <tr><td>72</td><td></td><td></td><td>48</td><td>47</td><td>46</td><td></td><td>44</td><td>43</td><td>41</td><td>40</td><td></td><td></td><td></td><td></td><td></td><td></td></tr> <tr><td>52</td><td></td><td></td><td></td><td>30</td><td></td><td></td><td></td><td></td><td></td><td></td><td></td><td></td><td>20</td><td>19</td><td>18</td><td></td></tr> <tr><td colspan="2">73</td><td></td><td>16</td><td>15</td><td>14</td><td></td><td></td><td></td><td></td><td></td><td></td><td></td><td>4</td><td></td><td></td><td></td></tr> </table>	72			48	47	46		44	43	41	40							52				30									20	19	18		73			16	15	14								4																							
72			48	47	46		44	43	41	40																																																																				
52				30									20	19	18																																																															
73			16	15	14								4																																																																	

ENTER DESCRIPTION IEC NO. UAU2014-0574 DRAWN BY SKRA JENDRANA 2013/10/08 CHKD: CHYK APPR: VKOSHY 2013/10/09 GO	QUALITY SYMBOLS ∇=0 ∇=0 ∇=0	GENERAL TOLERANCES (UNLESS SPECIFIED) <table border="1"> <tr><th></th><th>mm</th><th>INCH</th></tr> <tr><td>4 PLACES</td><td>±---</td><td>±---</td></tr> <tr><td>3 PLACES</td><td>±---</td><td>±---</td></tr> <tr><td>2 PLACES</td><td>±---</td><td>±---</td></tr> <tr><td>1 PLACE</td><td>±---</td><td>±---</td></tr> <tr><td>0 PLACE</td><td>±---</td><td>±---</td></tr> </table>		mm	INCH	4 PLACES	±---	±---	3 PLACES	±---	±---	2 PLACES	±---	±---	1 PLACE	±---	±---	0 PLACE	±---	±---	DIMENSION STYLE MM ONLY	SCALE 1:1	DESIGN UNITS METRIC	THIRD ANGLE PROJECTION
		mm	INCH																					
	4 PLACES	±---	±---																					
	3 PLACES	±---	±---																					
2 PLACES	±---	±---																						
1 PLACE	±---	±---																						
0 PLACE	±---	±---																						
DRAWN BY DATE SKRA JENDRANA 2011/02/14	CHECKED BY DATE MVANSLAMBROU 2011/02/14	APPROVED BY DATE _____	MATERIAL NO. SEE BOM TABLE	DOCUMENT NO. SD-34566-001	SHEET NO. 65 OF 68	TITLE MX123 66/73/80CKT HRNS CONN ASSY molex																		
ANGULAR ±--- DRAFT WHERE APPLICABLE MUST REMAIN WITHIN DIMENSIONS			THIS DRAWING CONTAINS INFORMATION THAT IS PROPRIETARY TO MOLEX INCORPORATED AND SHOULD NOT BE USED WITHOUT WRITTEN PERMISSION																					
SIZE D																								

STATUS	GM PART #	MATERIAL #	PART/MATERIAL REVISION	WIRE DRESS OPTION	KEY OPTION Fp	COLOR (TPA) Fp	NUMBERS INDICATE CAVITIES OPEN FOR CIRCUITS Fp																																																																												
AVAILABLE	NOT APPLICABLE	34566-5993	G	0	A	BLACK	<table border="1"> <tr><td>71</td><td>70</td><td>69</td><td>67</td><td>66</td><td>65</td><td>63</td><td>62</td><td>61</td><td>60</td><td>58</td><td>57</td><td>56</td><td>55</td><td>54</td><td>53</td></tr> <tr><td>52</td><td>51</td><td>50</td><td>49</td><td>47</td><td>45</td><td>44</td><td>43</td><td>42</td><td>41</td><td>40</td><td>39</td><td>37</td><td>36</td><td>35</td><td>34</td></tr> <tr><td colspan="2">73</td><td>32</td><td>31</td><td>30</td><td>29</td><td>28</td><td>27</td><td>26</td><td>25</td><td>24</td><td>23</td><td>21</td><td>20</td><td>19</td><td>18</td><td>17</td></tr> <tr><td colspan="2"></td><td>16</td><td>15</td><td>14</td><td>13</td><td>12</td><td>11</td><td>10</td><td>9</td><td>8</td><td>6</td><td>5</td><td>3</td><td>1</td><td></td><td></td></tr> </table>	71	70	69	67	66	65	63	62	61	60	58	57	56	55	54	53	52	51	50	49	47	45	44	43	42	41	40	39	37	36	35	34	73		32	31	30	29	28	27	26	25	24	23	21	20	19	18	17			16	15	14	13	12	11	10	9	8	6	5	3	1												
71	70	69	67	66	65	63	62	61	60	58	57	56	55	54	53																																																																				
52	51	50	49	47	45	44	43	42	41	40	39	37	36	35	34																																																																				
73		32	31	30	29	28	27	26	25	24	23	21	20	19	18	17																																																																			
		16	15	14	13	12	11	10	9	8	6	5	3	1																																																																					
AVAILABLE	NOT APPLICABLE	34566-6013	G	0	B	ST.GRAY	<table border="1"> <tr><td></td><td></td><td>69</td><td>67</td><td>65</td><td></td><td></td><td></td><td>61</td><td>60</td><td>59</td><td>58</td><td>57</td><td></td><td>54</td><td>53</td></tr> <tr><td>51</td><td>50</td><td>49</td><td>48</td><td>47</td><td>46</td><td>45</td><td>43</td><td></td><td>40</td><td>39</td><td>37</td><td>37</td><td></td><td>34</td><td>33</td></tr> <tr><td colspan="2">73</td><td>32</td><td>31</td><td>30</td><td>29</td><td></td><td></td><td>26</td><td>24</td><td>23</td><td>22</td><td>21</td><td>20</td><td>18</td><td></td></tr> <tr><td colspan="2"></td><td>16</td><td>15</td><td>14</td><td>13</td><td></td><td></td><td>10</td><td>9</td><td>8</td><td>7</td><td>6</td><td>5</td><td>4</td><td></td><td></td></tr> </table>			69	67	65				61	60	59	58	57		54	53	51	50	49	48	47	46	45	43		40	39	37	37		34	33	73		32	31	30	29			26	24	23	22	21	20	18				16	15	14	13			10	9	8	7	6	5	4													
		69	67	65				61	60	59	58	57		54	53																																																																				
51	50	49	48	47	46	45	43		40	39	37	37		34	33																																																																				
73		32	31	30	29			26	24	23	22	21	20	18																																																																					
		16	15	14	13			10	9	8	7	6	5	4																																																																					
AVAILABLE	NOT APPLICABLE	34566-6023	G	0	A	BLACK	<table border="1"> <tr><td>72</td><td>71</td><td>70</td><td>69</td><td>68</td><td>67</td><td></td><td></td><td></td><td></td><td>60</td><td>59</td><td>58</td><td>57</td><td>56</td><td>54</td><td>53</td></tr> <tr><td>52</td><td>51</td><td>50</td><td>49</td><td>48</td><td>47</td><td>45</td><td>44</td><td>43</td><td></td><td>40</td><td>39</td><td>38</td><td>37</td><td>36</td><td>35</td><td>34</td><td>33</td></tr> <tr><td colspan="2">73</td><td>32</td><td>31</td><td>30</td><td>29</td><td>28</td><td></td><td></td><td></td><td>24</td><td>23</td><td>22</td><td>21</td><td>20</td><td>19</td><td>17</td><td></td></tr> <tr><td colspan="2"></td><td>16</td><td>15</td><td>13</td><td>12</td><td>11</td><td>10</td><td></td><td></td><td>7</td><td>6</td><td>5</td><td>4</td><td>3</td><td>2</td><td>1</td><td></td></tr> </table>	72	71	70	69	68	67					60	59	58	57	56	54	53	52	51	50	49	48	47	45	44	43		40	39	38	37	36	35	34	33	73		32	31	30	29	28				24	23	22	21	20	19	17				16	15	13	12	11	10			7	6	5	4	3	2	1						
72	71	70	69	68	67					60	59	58	57	56	54	53																																																																			
52	51	50	49	48	47	45	44	43		40	39	38	37	36	35	34	33																																																																		
73		32	31	30	29	28				24	23	22	21	20	19	17																																																																			
		16	15	13	12	11	10			7	6	5	4	3	2	1																																																																			
AVAILABLE	NOT APPLICABLE	34566-6033	G	0	A	BLACK	<table border="1"> <tr><td></td><td></td><td>70</td><td>69</td><td></td><td></td><td></td><td></td><td>63</td><td>62</td><td>61</td><td></td><td></td><td>58</td><td>57</td><td>56</td><td>55</td><td>54</td><td>53</td></tr> <tr><td>52</td><td>51</td><td>49</td><td></td><td></td><td></td><td></td><td></td><td>44</td><td>43</td><td>42</td><td>41</td><td></td><td></td><td>37</td><td>36</td><td>34</td><td></td><td></td></tr> <tr><td colspan="2">73</td><td>32</td><td></td><td></td><td></td><td>29</td><td>28</td><td>27</td><td>26</td><td></td><td></td><td></td><td></td><td>21</td><td>19</td><td>18</td><td></td><td></td></tr> <tr><td colspan="2"></td><td>16</td><td>15</td><td></td><td></td><td>13</td><td>12</td><td>11</td><td>10</td><td>8</td><td></td><td></td><td></td><td>5</td><td>3</td><td></td><td></td><td></td></tr> </table>			70	69					63	62	61			58	57	56	55	54	53	52	51	49						44	43	42	41			37	36	34			73		32				29	28	27	26					21	19	18					16	15			13	12	11	10	8				5	3			
		70	69					63	62	61			58	57	56	55	54	53																																																																	
52	51	49						44	43	42	41			37	36	34																																																																			
73		32				29	28	27	26					21	19	18																																																																			
		16	15			13	12	11	10	8				5	3																																																																				
AVAILABLE	NOT APPLICABLE	34566-6043	G	0	B	ST.GRAY	<table border="1"> <tr><td></td><td></td><td></td><td>68</td><td>67</td><td>66</td><td>65</td><td>64</td><td></td><td></td><td></td><td></td><td></td><td>58</td><td></td><td>55</td><td></td><td></td><td></td></tr> <tr><td></td><td></td><td></td><td></td><td></td><td>46</td><td>45</td><td></td><td></td><td></td><td></td><td></td><td></td><td>38</td><td></td><td>35</td><td></td><td></td><td></td></tr> <tr><td colspan="2">73</td><td>32</td><td></td><td></td><td>30</td><td>29</td><td>28</td><td>27</td><td></td><td></td><td></td><td></td><td>22</td><td></td><td>19</td><td></td><td>17</td><td></td></tr> <tr><td colspan="2"></td><td>16</td><td></td><td></td><td></td><td></td><td></td><td>10</td><td></td><td></td><td></td><td></td><td></td><td></td><td></td><td></td><td></td><td>1</td></tr> </table>				68	67	66	65	64						58		55									46	45							38		35				73		32			30	29	28	27					22		19		17				16						10										1
			68	67	66	65	64						58		55																																																																				
					46	45							38		35																																																																				
73		32			30	29	28	27					22		19		17																																																																		
		16						10										1																																																																	
AVAILABLE	NOT APPLICABLE	34566-6053	G	0	B	ST.GRAY	<table border="1"> <tr><td>72</td><td></td><td></td><td></td><td></td><td></td><td></td><td></td><td></td><td>62</td><td>61</td><td></td><td></td><td></td><td></td><td></td><td></td><td></td><td></td></tr> <tr><td>52</td><td></td><td></td><td>48</td><td>47</td><td>46</td><td></td><td></td><td>43</td><td>41</td><td>40</td><td></td><td></td><td></td><td></td><td></td><td></td><td></td><td></td></tr> <tr><td colspan="2">73</td><td></td><td>32</td><td></td><td>30</td><td></td><td></td><td></td><td></td><td></td><td></td><td></td><td></td><td></td><td>20</td><td>19</td><td>18</td><td></td></tr> <tr><td colspan="2"></td><td></td><td>16</td><td>15</td><td>14</td><td></td><td></td><td></td><td></td><td></td><td></td><td></td><td></td><td></td><td>4</td><td></td><td>2</td><td></td></tr> </table>	72									62	61									52			48	47	46			43	41	40									73			32		30										20	19	18					16	15	14										4		2	
72									62	61																																																																									
52			48	47	46			43	41	40																																																																									
73			32		30										20	19	18																																																																		
			16	15	14										4		2																																																																		
AVAILABLE	NOT APPLICABLE	34566-6063	G	0	C	BLUE	<table border="1"> <tr><td></td><td></td><td>69</td><td>67</td><td>66</td><td>64</td><td>62</td><td>61</td><td>60</td><td></td><td></td><td></td><td>57</td><td></td><td>55</td><td>54</td><td></td><td></td><td></td></tr> <tr><td>52</td><td>51</td><td>50</td><td>48</td><td>46</td><td>45</td><td>44</td><td>42</td><td></td><td></td><td></td><td></td><td></td><td>37</td><td>35</td><td>34</td><td>33</td><td></td><td></td></tr> <tr><td colspan="2">73</td><td>32</td><td></td><td></td><td></td><td>28</td><td>27</td><td>26</td><td></td><td></td><td></td><td></td><td></td><td>19</td><td>18</td><td>17</td><td></td><td></td></tr> <tr><td colspan="2"></td><td>16</td><td>15</td><td>14</td><td>13</td><td>12</td><td>11</td><td>10</td><td>9</td><td></td><td></td><td></td><td></td><td></td><td></td><td></td><td></td><td></td></tr> </table>			69	67	66	64	62	61	60				57		55	54				52	51	50	48	46	45	44	42						37	35	34	33			73		32				28	27	26						19	18	17					16	15	14	13	12	11	10	9									
		69	67	66	64	62	61	60				57		55	54																																																																				
52	51	50	48	46	45	44	42						37	35	34	33																																																																			
73		32				28	27	26						19	18	17																																																																			
		16	15	14	13	12	11	10	9																																																																										
AVAILABLE	NOT APPLICABLE	34566-6073	G	0	C	BLUE	<table border="1"> <tr><td></td><td></td><td>69</td><td>67</td><td>66</td><td>64</td><td>62</td><td>61</td><td>60</td><td></td><td></td><td></td><td>57</td><td></td><td>54</td><td></td><td></td><td></td><td></td></tr> <tr><td>52</td><td>51</td><td>50</td><td>49</td><td>48</td><td>46</td><td>45</td><td>44</td><td>41</td><td></td><td></td><td></td><td></td><td>37</td><td></td><td>34</td><td>33</td><td></td><td></td></tr> <tr><td colspan="2">73</td><td>32</td><td></td><td></td><td></td><td>28</td><td>27</td><td>25</td><td></td><td></td><td></td><td></td><td></td><td></td><td>18</td><td>17</td><td></td><td></td></tr> <tr><td colspan="2"></td><td>16</td><td>15</td><td>14</td><td>13</td><td>12</td><td>11</td><td>10</td><td>9</td><td></td><td></td><td></td><td></td><td></td><td></td><td></td><td></td><td></td></tr> </table>			69	67	66	64	62	61	60				57		54					52	51	50	49	48	46	45	44	41					37		34	33			73		32				28	27	25							18	17					16	15	14	13	12	11	10	9									
		69	67	66	64	62	61	60				57		54																																																																					
52	51	50	49	48	46	45	44	41					37		34	33																																																																			
73		32				28	27	25							18	17																																																																			
		16	15	14	13	12	11	10	9																																																																										
AVAILABLE	NOT APPLICABLE	34566-6083	G	0	C	BLUE	<table border="1"> <tr><td>72</td><td>70</td><td>68</td><td>67</td><td>66</td><td></td><td>63</td><td>62</td><td></td><td></td><td>59</td><td>57</td><td></td><td></td><td></td><td></td><td></td><td></td><td>53</td></tr> <tr><td>52</td><td>51</td><td></td><td>48</td><td>47</td><td>46</td><td>44</td><td>42</td><td>40</td><td>39</td><td></td><td>37</td><td>36</td><td></td><td>34</td><td>33</td><td></td><td></td><td></td></tr> <tr><td colspan="2">73</td><td></td><td>32</td><td></td><td>30</td><td></td><td></td><td>26</td><td>25</td><td></td><td>22</td><td>21</td><td></td><td></td><td></td><td></td><td></td><td></td></tr> <tr><td colspan="2"></td><td></td><td>15</td><td>14</td><td></td><td></td><td></td><td>10</td><td>9</td><td></td><td>6</td><td>5</td><td>4</td><td>2</td><td></td><td></td><td></td><td></td></tr> </table>	72	70	68	67	66		63	62			59	57							53	52	51		48	47	46	44	42	40	39		37	36		34	33				73			32		30			26	25		22	21										15	14				10	9		6	5	4	2				
72	70	68	67	66		63	62			59	57							53																																																																	
52	51		48	47	46	44	42	40	39		37	36		34	33																																																																				
73			32		30			26	25		22	21																																																																							
			15	14				10	9		6	5	4	2																																																																					

ENTER DESCRIPTION IEC NO. UAU2014-0574 DRAWNSKRAJENDRANA 2013/10/08 CHKD: APPR:VKOSHY 2013/10/09 REY:	QUALITY SYMBOLS	GENERAL TOLERANCES (UNLESS SPECIFIED)	DIMENSION STYLE	SCALE	DESIGN UNITS	THIRD ANGLE PROJECTION
	▽=0	mm INCH	MM ONLY	1:1	METRIC	
	▽=0	4 PLACES ± --- ± ---	DRAWN BY DATE	TITLE		
	▽=0	3 PLACES ± --- ± ---	SKRAJENDRANA 2011/02/14	MX123 66/73/80CKT HRNS CONN ASSY		
▽=0	2 PLACES ± --- ± ---	CHECKED BY DATE	APPROVED BY DATE			
	1 PLACE ± --- ± ---	MVANS LAMBROU 2011/02/14				
	0 PLACE ± --- ± ---					
	ANGULAR ± ---	MATERIAL NO.	DOCUMENT NO.			
	DRAFT WHERE APPLICABLE MUST REMAIN WITHIN DIMENSIONS	SEE BOM TABLE	SD-34566-001			
		SIZE D	THIS DRAWING CONTAINS INFORMATION THAT IS PROPRIETARY TO MOLEX INCORPORATED AND SHOULD NOT BE USED WITHOUT WRITTEN PERMISSION			

STATUS	GM PART #	MATERIAL #	PART/MATERIAL REVISION	WIRE DRESS OPTION	KEY OPTION Fp	COLOR (TPA) Fp	NUMBERS INDICATE CAVITIES OPEN FOR CIRCUITS Fp																																																																																			
AVAILABLE	NOT APPLICABLE	34566-6093	G	0	B	ST.GRAY	<table border="1"> <tr><td>72</td><td>70</td><td></td><td>67</td><td></td><td></td><td>63</td><td>62</td><td>61</td><td>60</td><td>59</td><td></td><td></td><td></td><td></td><td></td><td></td><td></td><td></td><td></td></tr> <tr><td>52</td><td></td><td></td><td></td><td></td><td></td><td>46</td><td>43</td><td>41</td><td>40</td><td></td><td></td><td></td><td></td><td></td><td></td><td></td><td></td><td>20</td><td>19</td><td>18</td></tr> <tr><td></td><td>73</td><td></td><td></td><td></td><td></td><td></td><td>27</td><td></td><td></td><td></td><td></td><td></td><td></td><td></td><td></td><td></td><td></td><td></td><td></td><td></td></tr> <tr><td></td><td></td><td>16</td><td>14</td><td></td><td></td><td>11</td><td></td><td></td><td></td><td></td><td></td><td></td><td></td><td></td><td></td><td></td><td></td><td>4</td><td></td><td></td></tr> </table>	72	70		67			63	62	61	60	59										52						46	43	41	40									20	19	18		73						27																16	14			11												4		
72	70		67			63	62	61	60	59																																																																																
52						46	43	41	40									20	19	18																																																																						
	73						27																																																																																			
		16	14			11												4																																																																								
AVAILABLE	NOT APPLICABLE	34566-6113	G	0	A	BLACK	<table border="1"> <tr><td>72</td><td>71</td><td>70</td><td>69</td><td>68</td><td>66</td><td>65</td><td>64</td><td>63</td><td>62</td><td>61</td><td>60</td><td></td><td>58</td><td>57</td><td>56</td><td>55</td><td>54</td><td>53</td><td></td></tr> <tr><td>52</td><td>51</td><td>50</td><td>49</td><td>48</td><td>46</td><td>45</td><td>44</td><td>43</td><td>42</td><td>41</td><td>40</td><td>39</td><td>38</td><td>37</td><td>36</td><td></td><td>34</td><td>33</td><td></td></tr> <tr><td></td><td>73</td><td></td><td></td><td>32</td><td>31</td><td>30</td><td>29</td><td>28</td><td>27</td><td>26</td><td>25</td><td>23</td><td>22</td><td>21</td><td>20</td><td>19</td><td>18</td><td></td><td></td></tr> <tr><td></td><td></td><td></td><td></td><td>16</td><td>15</td><td>14</td><td>13</td><td>12</td><td>11</td><td>10</td><td>9</td><td>8</td><td>7</td><td>6</td><td>5</td><td>4</td><td>3</td><td>2</td><td></td></tr> </table>	72	71	70	69	68	66	65	64	63	62	61	60		58	57	56	55	54	53		52	51	50	49	48	46	45	44	43	42	41	40	39	38	37	36		34	33			73			32	31	30	29	28	27	26	25	23	22	21	20	19	18							16	15	14	13	12	11	10	9	8	7	6	5	4	3	2				
72	71	70	69	68	66	65	64	63	62	61	60		58	57	56	55	54	53																																																																								
52	51	50	49	48	46	45	44	43	42	41	40	39	38	37	36		34	33																																																																								
	73			32	31	30	29	28	27	26	25	23	22	21	20	19	18																																																																									
				16	15	14	13	12	11	10	9	8	7	6	5	4	3	2																																																																								
AVAILABLE	NOT APPLICABLE	34566-6123	G	0	C	BLUE	<table border="1"> <tr><td></td><td></td><td></td><td>69</td><td>67</td><td>66</td><td></td><td>64</td><td></td><td>62</td><td></td><td>60</td><td></td><td></td><td>57</td><td></td><td></td><td></td><td>54</td><td></td></tr> <tr><td>52</td><td>51</td><td>50</td><td></td><td>48</td><td>46</td><td>45</td><td>44</td><td></td><td>42</td><td></td><td></td><td></td><td></td><td>37</td><td></td><td></td><td></td><td>34</td><td>33</td></tr> <tr><td></td><td>73</td><td></td><td></td><td></td><td></td><td></td><td>28</td><td>27</td><td>26</td><td></td><td></td><td></td><td></td><td></td><td></td><td></td><td></td><td></td><td></td></tr> <tr><td></td><td></td><td></td><td></td><td>16</td><td>15</td><td>14</td><td>13</td><td>12</td><td>11</td><td>10</td><td>9</td><td>8</td><td>7</td><td></td><td></td><td></td><td></td><td></td><td></td></tr> </table>				69	67	66		64		62		60			57				54		52	51	50		48	46	45	44		42					37				34	33		73						28	27	26															16	15	14	13	12	11	10	9	8	7									
			69	67	66		64		62		60			57				54																																																																								
52	51	50		48	46	45	44		42					37				34	33																																																																							
	73						28	27	26																																																																																	
				16	15	14	13	12	11	10	9	8	7																																																																													
AVAILABLE	NOT APPLICABLE	34566-6133	G	9	C	BLUE	<table border="1"> <tr><td>72</td><td>70</td><td></td><td>68</td><td>67</td><td></td><td></td><td></td><td>63</td><td>62</td><td></td><td></td><td></td><td>59</td><td></td><td>57</td><td></td><td></td><td></td><td>53</td></tr> <tr><td>52</td><td>51</td><td></td><td>48</td><td>47</td><td></td><td></td><td>44</td><td></td><td>42</td><td></td><td></td><td>40</td><td>39</td><td>38</td><td>37</td><td>36</td><td></td><td>34</td><td>33</td></tr> <tr><td></td><td>73</td><td></td><td></td><td></td><td>32</td><td>31</td><td>30</td><td></td><td>26</td><td>25</td><td>24</td><td></td><td>22</td><td>21</td><td></td><td></td><td></td><td></td><td></td></tr> <tr><td></td><td></td><td></td><td></td><td></td><td>15</td><td>14</td><td></td><td></td><td></td><td>9</td><td>8</td><td></td><td>6</td><td>5</td><td>4</td><td></td><td></td><td></td><td>2</td></tr> </table>	72	70		68	67				63	62				59		57				53	52	51		48	47			44		42			40	39	38	37	36		34	33		73				32	31	30		26	25	24		22	21											15	14				9	8		6	5	4				2			
72	70		68	67				63	62				59		57				53																																																																							
52	51		48	47			44		42			40	39	38	37	36		34	33																																																																							
	73				32	31	30		26	25	24		22	21																																																																												
					15	14				9	8		6	5	4				2																																																																							
GS AVAILABLE	NOT APPLICABLE	34566-6173	G	9	B	ST.GRAY	<table border="1"> <tr><td></td><td></td><td></td><td></td><td>67</td><td>66</td><td></td><td></td><td></td><td></td><td></td><td></td><td></td><td></td><td></td><td></td><td></td><td></td><td></td><td></td></tr> <tr><td></td><td></td><td></td><td></td><td>48</td><td>47</td><td></td><td></td><td></td><td>41</td><td></td><td></td><td></td><td></td><td></td><td></td><td></td><td></td><td></td><td></td></tr> <tr><td></td><td>73</td><td></td><td></td><td>32</td><td>31</td><td>30</td><td>29</td><td></td><td>27</td><td>26</td><td>25</td><td>24</td><td></td><td>22</td><td>21</td><td></td><td>19</td><td>18</td><td>17</td></tr> <tr><td></td><td></td><td></td><td></td><td>16</td><td>15</td><td>14</td><td>13</td><td></td><td>11</td><td>10</td><td>9</td><td>8</td><td>7</td><td>6</td><td>5</td><td>4</td><td>3</td><td></td><td>1</td></tr> </table>					67	66																			48	47				41												73			32	31	30	29		27	26	25	24		22	21		19	18	17					16	15	14	13		11	10	9	8	7	6	5	4	3		1			
				67	66																																																																																					
				48	47				41																																																																																	
	73			32	31	30	29		27	26	25	24		22	21		19	18	17																																																																							
				16	15	14	13		11	10	9	8	7	6	5	4	3		1																																																																							
GS AVAILABLE	NOT APPLICABLE	34566-6183	G	9	A	BLACK	<table border="1"> <tr><td></td><td></td><td></td><td></td><td>48</td><td>47</td><td></td><td></td><td></td><td>41</td><td></td><td></td><td></td><td></td><td></td><td></td><td></td><td></td><td></td><td></td></tr> <tr><td></td><td>73</td><td></td><td></td><td>32</td><td>31</td><td>30</td><td>29</td><td></td><td>27</td><td>26</td><td>25</td><td>24</td><td></td><td>22</td><td>21</td><td></td><td>19</td><td>18</td><td>17</td></tr> <tr><td></td><td></td><td></td><td></td><td>16</td><td>15</td><td>14</td><td>13</td><td></td><td>11</td><td>10</td><td>9</td><td>8</td><td>7</td><td>6</td><td>5</td><td>4</td><td>3</td><td></td><td>1</td></tr> </table>					48	47				41												73			32	31	30	29		27	26	25	24		22	21		19	18	17					16	15	14	13		11	10	9	8	7	6	5	4	3		1																							
				48	47				41																																																																																	
	73			32	31	30	29		27	26	25	24		22	21		19	18	17																																																																							
				16	15	14	13		11	10	9	8	7	6	5	4	3		1																																																																							
GS AVAILABLE	NOT APPLICABLE	34566-6193	G	9	B	ST.GRAY	<table border="1"> <tr><td>72</td><td>71</td><td>70</td><td>69</td><td>68</td><td>67</td><td>66</td><td>65</td><td>64</td><td></td><td>62</td><td>61</td><td>60</td><td>59</td><td>58</td><td>57</td><td>56</td><td>55</td><td>54</td><td></td></tr> <tr><td>52</td><td>51</td><td>50</td><td>49</td><td></td><td></td><td>46</td><td></td><td>44</td><td></td><td>41</td><td>40</td><td></td><td></td><td>38</td><td>37</td><td>36</td><td></td><td></td><td></td></tr> <tr><td></td><td>73</td><td></td><td></td><td></td><td></td><td>32</td><td>31</td><td>30</td><td>29</td><td>28</td><td>27</td><td>26</td><td>25</td><td>24</td><td></td><td>21</td><td>20</td><td></td><td>18</td><td>17</td></tr> <tr><td></td><td></td><td></td><td></td><td></td><td></td><td>16</td><td>15</td><td>14</td><td>13</td><td>12</td><td>10</td><td>9</td><td>8</td><td>7</td><td>6</td><td>5</td><td>4</td><td>3</td><td>2</td><td></td></tr> </table>	72	71	70	69	68	67	66	65	64		62	61	60	59	58	57	56	55	54		52	51	50	49			46		44		41	40			38	37	36					73					32	31	30	29	28	27	26	25	24		21	20		18	17							16	15	14	13	12	10	9	8	7	6	5	4	3	2		
72	71	70	69	68	67	66	65	64		62	61	60	59	58	57	56	55	54																																																																								
52	51	50	49			46		44		41	40			38	37	36																																																																										
	73					32	31	30	29	28	27	26	25	24		21	20		18	17																																																																						
						16	15	14	13	12	10	9	8	7	6	5	4	3	2																																																																							

ENTER DESCRIPTION IEC NO: UAU2014-0574 DRAWN BY: SKRAJENDRANA 2013/10/08 CHKD: CHYKZ APPR: VKOSHY 2013/10/09	QUALITY SYMBOLS ∇=0 ∇=0 ∇=0	GENERAL TOLERANCES (UNLESS SPECIFIED) mm INCH 4 PLACES # --- # --- 3 PLACES # --- # --- 2 PLACES # --- # --- 1 PLACE # --- # --- 0 PLACE # --- # ---	DIMENSION STYLE MM ONLY	SCALE 1:1	DESIGN UNITS METRIC	THIRD ANGLE PROJECTION
	DRAWN BY: SKRAJENDRANA 2011/02/14 CHECKED BY: MVANSLAMBROU 2011/02/14 APPROVED BY:	DATE:	DATE:	DATE:	DATE:	DATE:
MATERIAL NO.	DOCUMENT NO.	SHEET NO.	MX123 66/73/80CKT HRNS CONN ASSY molex SD-34566-001 68 OF 68			

THIS DRAWING CONTAINS INFORMATION THAT IS PROPRIETARY TO MOLEX INCORPORATED AND SHOULD NOT BE USED WITHOUT WRITTEN PERMISSION