

Technical requirements

1- PRODUCT DESCRIPTION

Harness with an UTL1102G1W3P overmolded with resistance

2- REFERENCE DOCUMENTS

NPRDS_IC134602B

3- SUPPLY REQUIREMENTS

No requirement

4- LOTISSEMENT

several manufacturing batch allowed for a single delivery

5- TRACABILITY

Product reference + date code + quantity

6- DELIVERY CONDITIONS

Individual harness packing, serie packed in bulk.

7- TECHNICAL REQUIREMENTS

Presence of all parts specified on the drawing.
Automatic conformity control of all harnesses.

Sealing: IP68 - under water for 1 week, 1 bar

Electrical tests :

Continuity between A and B: mini 120Ω

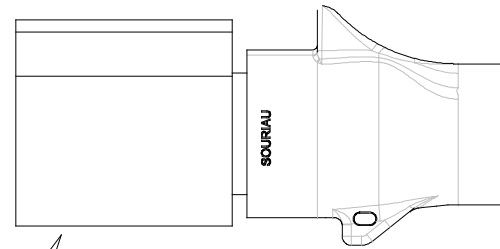

Connecteur UTL1102G1W3P surmoulé
Connector UTL1102G1W3P overmolded

REFERENCE ARTICLE: UTL1102G1W3PCDMX

CUSTOMER DRAWING

Schéma de câblage cabling table

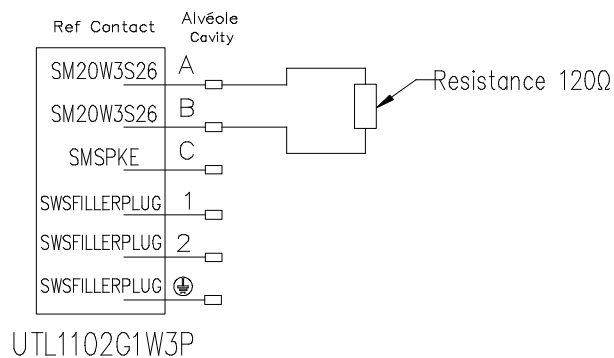

B	13/02/14	Modif de la réf	E.Hmouch	--
IND	DATE	LIBELLE	EMIS PAR	CONTROLE PAR N'DIFFUSION
DEFINI PAR : R.LACHHAB		LE: 12/02/14	TYPE DE PLAN: client	
VERIFIE PAR: F.DERKAQUI		LE: 12/02/14	Dimensions en mm / Dimensions in mm	
LES COTES S'ENTENDENT AVANT PROTECTION / FINITION				
DENOMINATION: Harnais UTL1102G1W3P surmoulé + Resistance 1200hms Harness UTL1102G1W3P overmolded + Resistance 1200hms				
ECHELLE	TOLERANCES GENERALES ANGULAIRES: ± - LINEAIRES : ± -	MATIERE: - -	N°: -	
USINAGE GENERAL ETAT DE SURFACE		PROTECTION: -	REFERENCE MATERIEL	CODE: -
		DEFAUTS DE GEOMETRIE VOIR NF E 04-552	REFERENCE MATERIEL	AFFAIRE
		CE DOCUMENT EST LA PROPRIETE DE SOURIAU IL NE PEUT ETRE REPRODUIT OU COMMUNIQUE SANS SON AUTORISATION		
FORMAT	REFERENCE PLAN			FOLIO
A4	HA211961A-C01			1/1