

### Top View of Assembly

### SECTION A-A End View of Assembly

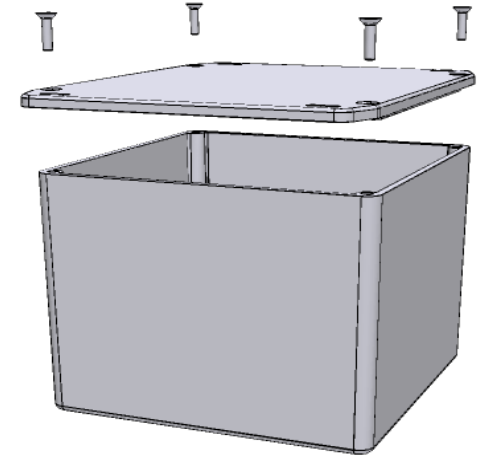

### SECTION B-B Side View of Assembly

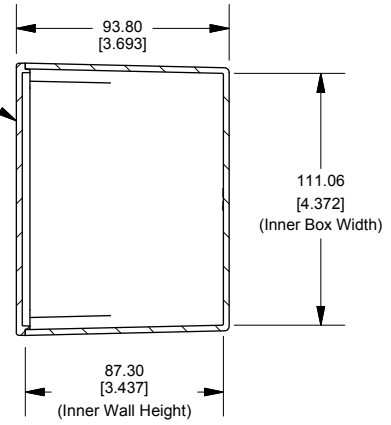
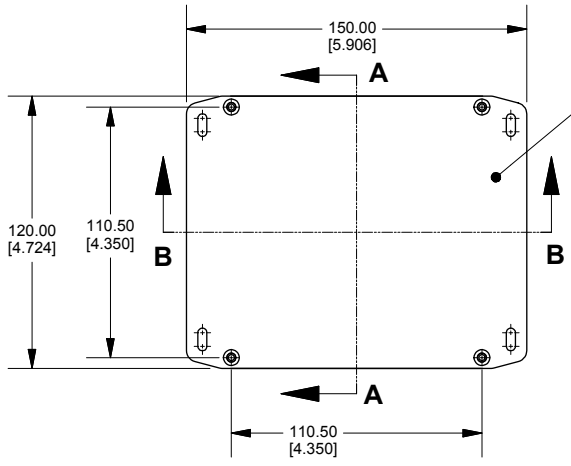
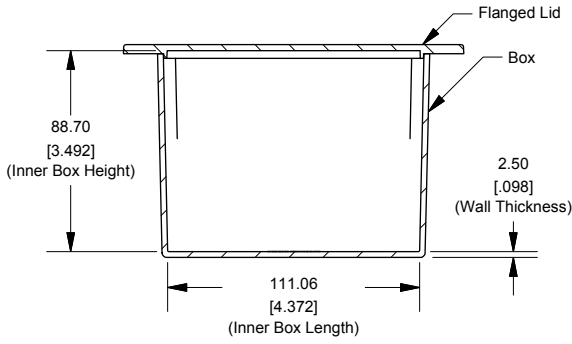

### Top View Looking Inside Box

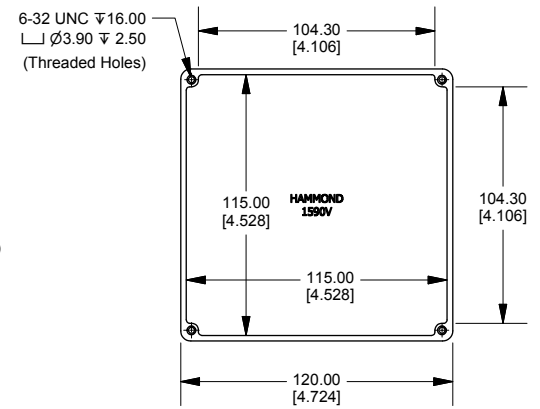

Enclosures can be Factory Modified ( Milling, Drilling, Printing etc.)  
 Contact Factory [mjm@hammondmfg.com](mailto:mjm@hammondmfg.com) for quotes  
 Solid models of this enclosure available in STEP or IGES.

NOTE	
Purchased assembly includes box, lid and 4 cover screws.	
Box and lid are made from Diecast Aluminum Alloy.	
Silicone Gasket supplied with liquid resistant enclosure.	

PART NUMBERS	
<b>1590VFL Enclosure</b>	
Natural Finish Enclosure	1590VFL
Black Textured Enclosure	1590VFLBK
<b>1590VFL Liquid Resistant Enclosure (Silicone Gasket)</b>	
Natural Finish Enclosure	1590WVFL
Black Textured Enclosure	1590WVFLBK
ACCESSORIES	
<b>Recommended Torque: 75 ozf.in / 55 cN.m</b>	
<b>Liquid Resistant Cover Screws</b>	
Stainless Steel Cover Screws (Pkg 100) [6-32 x 1/2" With O-Ring]	1590WMS100
Black Stainless Steel Cover Screws (Pkg 100) [6-32 x 1/2" With O-Ring]	1590WMS100BK
<b>Standard Cover Screws</b>	
Plated Cover Screws (Pkg 100) [6-32 x 1/2"]	1590MS100
Black Cover Screws (Pkg 100) [6-32 x 1/2"]	1590MS100BK

### Flanged Lid

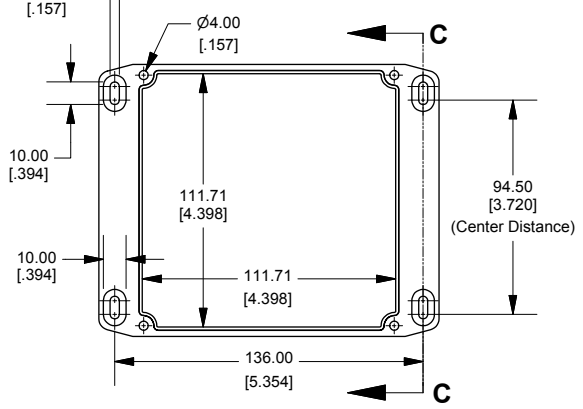

### SECTION C-C Side View of Slot

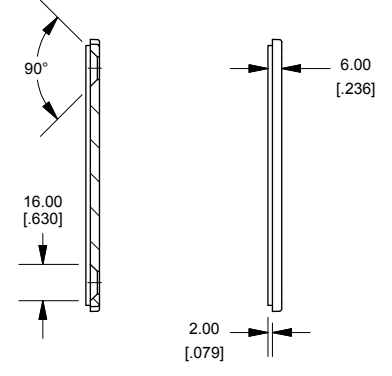

Dimensions:  
mm  
[inches]