

TOP VIEW OF ASSEMBLY

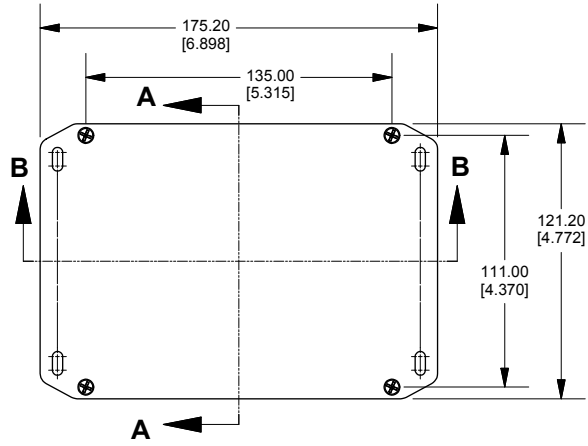

SECTION A-A END VIEW OF ASSEMBLY

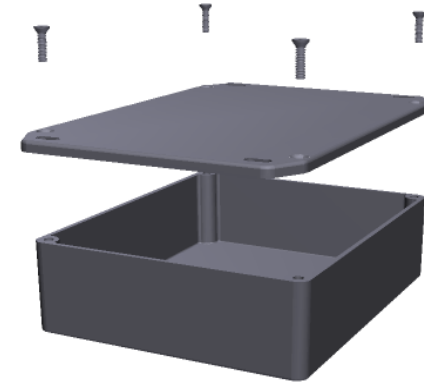
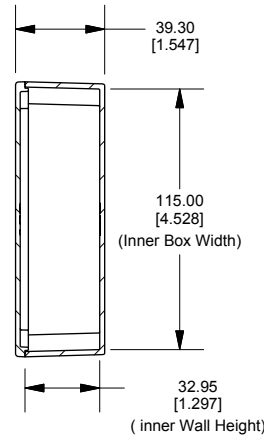

SECTION B-B SIDE VIEW OF ASSEMBLY

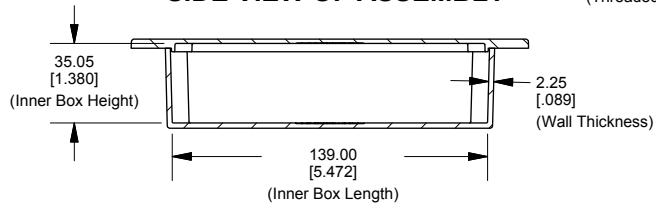

TOP VIEW LOOKING INSIDE BOX

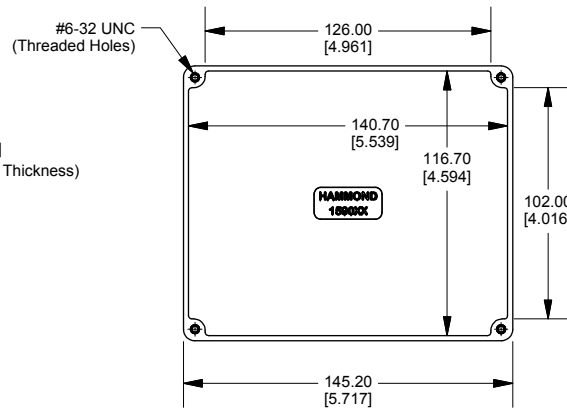

FLANGED LID

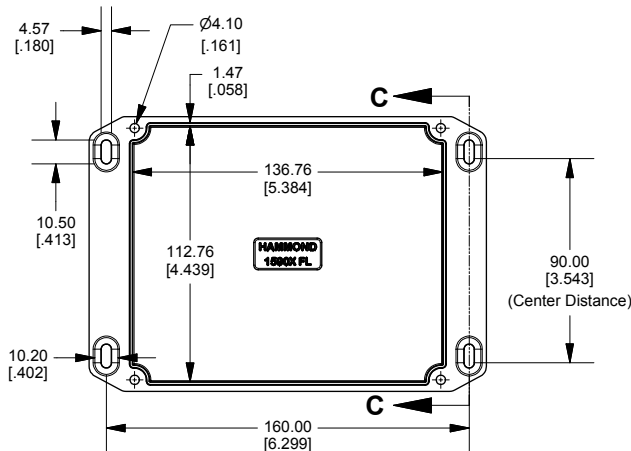

SECTION C-C Side View of Slot

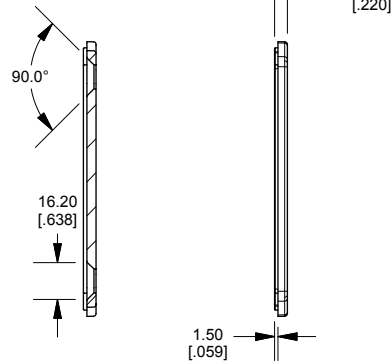

Enclosures can be Factory Modified (Milling, Drilling, Printing etc.)
 Contact Factory mjm@hammondmfg.com for quotes
 Solid models of this enclosure available in STEP or IGES.

NOTE

Purchased assembly includes box, lid and 4 cover screws.
 Box and lid are made from Diecast Aluminum Alloy.
 Silicone Gasket supplied with liquid resistant enclosure.

PART NUMBERS

1590XXFL Enclosure	
Natural Finish Enclosure	1590XXFL
Black Textured Enclosure	1590XXFLBK
1590XXFL Liquid Resistant Enclosure (Silicone Gasket)	
Natural Finish Enclosure	1590W XXFL
Black Textured Enclosure	1590W XXFLBK

ACCESSORIES

Recommended Torque: 75 ozf.in / 55 cN.m

Liquid Resistant Cover Screws

Stainless Steel Cover Screws (Pkg 100) [6-32 x 1/2" With O-Ring]	1590W MS100
Black Stainless Steel Cover Screws (Pkg 100) [6-32 x 1/2" With O-Ring]	1590W MS100BK

Standard Cover Screws

Plated Cover Screws (Pkg 100) [6-32 x 1/2"]	1590MS100
Black Cover Screws (Pkg 100) [6-32 x 1/2"]	1590MS100BK

HAMMOND MANUFACTURING™
1590XXFL
www.hammondmfg.com

Dimensions:
 mm
 [inches]