

SEC Z-Z
FOR 3 POLE ONLY

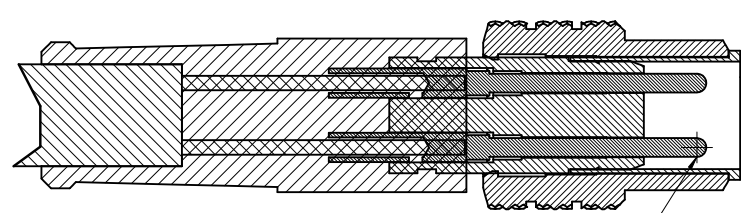

SEC Y-Y
FOR 4-5 POLE ONLY

MALE INSERT FRONT VIEW		
3 POLE	4 POLE	5 POLE
1 BROWN 3 BLUE 4 BLACK	1 BROWN 2 WHITE 3 BLUE 4 BLACK	1 BROWN 2 WHITE 3 BLUE 4 BLACK 5 GREY

ENTER DESCRIPTION EC NO: WEU2012-0001 DRWNRSCHIEBER 2011/06/22 CHKDRHEISSNER 2011/07/13 APPR:CBURGER 2011/07/20	DESCRIPTION REV
---	--------------------

QUALITY SYMBOLS ▽=0 ▽=0	GENERAL TOLERANCES (UNLESS SPECIFIED) <table border="1"> <tr> <th></th> <th>mm</th> <th>INCH</th> </tr> <tr> <td>4 PLACES</td> <td>± .005</td> <td>± .0002</td> </tr> <tr> <td>3 PLACES</td> <td>± .005</td> <td>± .0002</td> </tr> <tr> <td>2 PLACES</td> <td>± .01</td> <td>± .0004</td> </tr> <tr> <td>1 PLACE</td> <td>± 0.3</td> <td>± .0118</td> </tr> </table> ANGULAR ±1/2° DRAFT WHERE APPLICABLE MUST REMAIN WITHIN DIMENSIONS		mm	INCH	4 PLACES	± .005	± .0002	3 PLACES	± .005	± .0002	2 PLACES	± .01	± .0004	1 PLACE	± 0.3	± .0118
	mm	INCH														
4 PLACES	± .005	± .0002														
3 PLACES	± .005	± .0002														
2 PLACES	± .01	± .0004														
1 PLACE	± 0.3	± .0118														

DIMENSION STYLE IN/MM DRAWN BY BWOODMAN CHECKED BY RSTONE APPROVED BY JFMURPHY	DATE 18/08/09 DATE 18/08/09 DATE 18/08/09
---	--

SCALE 5:1 DESIGN UNITS INCH THIRD ANGLE PROJECTION	TITLE CSE M8 XP MA STR PUR PVC UN	MATERIAL NO. SEE CHART	DOCUMENT NO. SD-120027-002	SHEET NO. 1 OF 2
--	---	---------------------------	-------------------------------	---------------------

THIS DRAWING CONTAINS INFORMATION THAT IS PROPRIETARY TO MOLEX INCORPORATED AND SHOULD NOT BE USED WITHOUT WRITTEN PERMISSION

				ASSEMBLY		
				3 POLE	4 POLE	5 POLE
SL.No	DESCRIPTION	MATERIAL	FINISH	QTY		
1	STAMP & FORM CONTACT	COPPER ALLOY	GOLD PLATED	3		
2	SCREW MACHINE CONTACT	COPPER ALLOY	GOLD PLATED		4	5
3	SLEEVE	BRASS	NICKEL PLATED			
4	COUPLING NUT	BRASS	NICKEL PLATED			
5	LABEL	PLASTIC FILM	BLACK/YELLOW	1	1	1
6	OVER MOLD	TPE	YELLOW			
7	CABLE, 24 AWG, 3 CONDUCTOR	PUR JACKET	BLACK	1		
	CABLE, 24 AWG, 4 CONDUCTOR	PUR JACKET	BLACK		1	
	CABLE, 24 AWG, 4 CONDUCTOR	PVC JACKET	BLACK		1	
	CABLE, 24 AWG, 5 CONDUCTOR	PUR JACKET	BLACK			1
8	INSERT MALE 3 POLE	PUR	BLACK	1		
	INSERT MALE 4 POLE	PUR	BLACK		1	
	INSERT MALE 5 POLE	PUR	BLACK			1

PART NUMBER	DESCRIPTION	FINISHED LENGTH	MATERIAL
1200271079	403006P02M010	1M +60MM -0 [3' 3" +2.19" -0]	PUR
1200270911	403006P02M020	2M +90MM -0 [6' 6" +3.5" -0]	PUR
1200270453	403006P02M040	4M +150MM -0 [13' 1" +6" -0]	PUR
1200860474	403006P02M050	5M +150MM -0 [16' 4" +6" -0]	PUR
1200860583	403006P02M060	6M +150MM -0 [19' 7" +6" -0]	PUR
1200270933	403006P02M100	10M +300MM -0 [32' 4" +12" -0]	PUR
1200868372	404006P02M010	1M +60MM -0 [3' 3" +2.19" -0]	PUR
1200868373	404006P02M020	2M +90MM -0 [6' 6" +3.5" -0]	PUR
1200860584	404006P02M040	4M +150MM -0 [13' 1" +6" -0]	PUR
1200868375	404006P02M050	5M +150MM -0 [16' 4" +6" -0]	PUR
1200860585	404006P02M060	6M +150MM -0 [19' 7" +6" -0]	PUR
1200271137	404006P02M100	10M +300MM -0 [32' 4" +12" -0]	PUR
1200270752	405006P02M020	2M +90MM -0 [6' 6" +3.5" -0]	PUR
1200860586	405006P02M040	4M +150MM -0 [13' 1" +6" -0]	PUR
1200270657	405006P02M050	5M +150MM -0 [16' 4" +6" -0]	PUR
1200860587	405006P02M060	6M +150MM -0 [19' 7" +6" -0]	PUR
1200860588	405006P02M100	10M +300MM -0 [32' 4" +12" -0]	PUR
1200868161	404006E02M010	1M +60MM -0 [3' 3" +2.19" -0]	PVC
1200868368	404006E02M020	2M +90MM -0 [6' 6" +3.5" -0]	PVC
1200270376	404006E02M050	5M +150MM -0 [16' 4" +6" -0]	PVC

SPECIFICATION
Protection Class - IP67
Voltage Rating - 3 Pole/60V, 4+5 Pole/30V
Contact Current Rating - 3 Amps
Wires: 0.25mm ² PVC/PUR

ENTER DESCRIPTION EC NO: WEU2012-0001 DRAWN BY: SCHIEBER 2011/06/22 CHKD: REISSNER 2011/07/13 APPR: LOURGER 2011/07/20 B	QUALITY SYMBOLS ▽=0 ▽=0	GENERAL TOLERANCES (UNLESS SPECIFIED)		DIMENSION STYLE IN/MM		SCALE 5:1	DESIGN UNITS INCH	THIRD ANGLE PROJECTION	
		4 PLACES ± --- ± --- 3 PLACES ± --- ± --- 2 PLACES ± --- ± .01 1 PLACE ± 0.3 ± ---	mm INCH	DRAWN BY BWOODMAN	DATE 18/08/09	TITLE CSE M8 XP MA STR PUR PVC UN			
		ANGULAR ± 1/2°	DRAFT WHERE APPLICABLE MUST REMAIN WITHIN DIMENSIONS	CHECKED BY RSTONE	DATE 18/08/09	MOLEX INCORPORATED			
		SEE CHART	MATERIAL NO.	APPROVED BY JFMURPHY	DATE 18/08/09	DOCUMENT NO. SD-120027-002	SHEET NO. 2 OF 2		

THIS DRAWING CONTAINS INFORMATION THAT IS PROPRIETARY TO MOLEX INCORPORATED AND SHOULD NOT BE USED WITHOUT WRITTEN PERMISSION

STRAIGHT PLUG

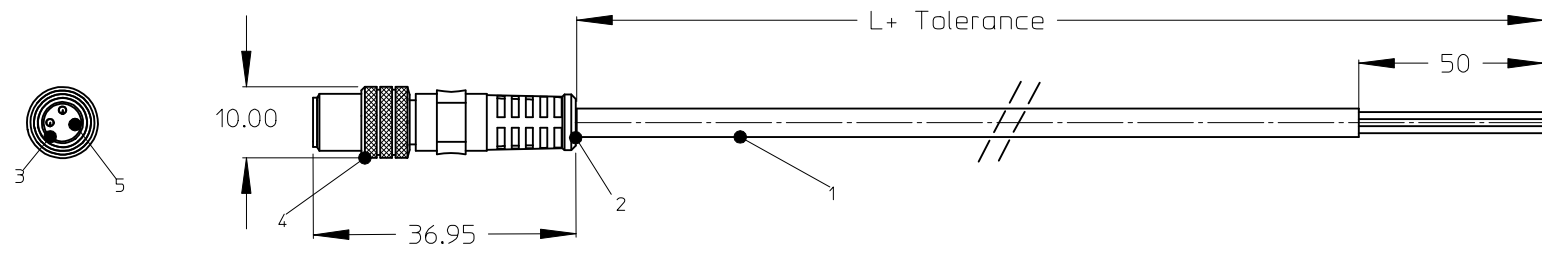

NOTES:

Temperatur Range -25°C/+80°C
 Contact Current Rating 3A
 Voltage Rating 3 poles 60V
 4-5 poles 30V
 Protection class IP 67

Cable:

E02 = 0,25mm², PVC black
 H08 = 0,25mm², PUR black, LSOH
 I02 = 0,25mm², PVC grey irradiated
 P02 = 0,25mm², PUR/PVC black
 P08 = 0,25mm², PUR yellow HIFLEX

Tolerance:

≤ 1 m	+20/-10 mm
1 m - 5 m	± 25 mm
5 m - 10 m	± 30 mm
> 10 m	± 30 mm
> 20 m	± 50 mm
> 30 m	± 60 mm

5	Contact	Copper Alloy	Gold Plated
4	Coupling Nut	Brass	Ni Plated
3	Insert	PUR	---
2	Overmold	PUR	---
1	Cable	See Table	---
ITEM	Part	Material	Finish

3 WIRE		4 WIRE		5 WIRE	
4	3	2	4	2	4
1	3	1	3	1	3
Pin #.	Wire	Pin #.	Wire	Pin #.	Wire
1	Brown	1	Brown	1	Brown
2	-	2	White	2	White
3	Blue	3	Blue	3	Blue
4	Black	4	Black	4	Black
5	-	5	-	5	Grey

ENTER DESCRIPTION EC NO: IPG2014-1068 DRWN:BBRAUCH CHKD: APPR:APOHL	2013/12/09	2013/12/09
	DESCRIPTION	REVISION
	3	
	3	

QUALITY SYMBOLS

▽=0
 ▽=0

GENERAL TOLERANCES (UNLESS SPECIFIED)

	mm	INCH
4 PLACES	± ---	± ---
3 PLACES	± ---	± ---
2 PLACES	± ---	± ---
1 PLACE	± 0.3	± ---

ANGULAR ± 1 °

DRAFT WHERE APPLICABLE
MUST REMAIN
WITHIN DIMENSIONS

DIMENSION STYLE
MM ONLY

DRAWN BY DATE
APOHL 2011/08/24

CHECKED BY DATE
REISSNER 2012/01/13

APPROVED BY DATE
AVOGT 2012/01/18

MATERIAL NO.
SEE TABLE

SIZE
A 4

SCALE 1:1

DESIGN UNITS METRIC

THIRD ANGLE PROJECTION

TITLE
CSE M8 XP XC MA STR XM
SE UNSH
NANO-CHANGE

molex MOLEX INCORPORATED

DOCUMENT NO. SD-120086-002

SHEET NO. 1 OF 3

THIS DRAWING CONTAINS INFORMATION THAT IS PROPRIETARY TO MOLEX INCORPORATED AND SHOULD NOT BE USED WITHOUT WRITTEN PERMISSION

NUMERICAL CODE (Available parts see table page 3 ff others on request.)

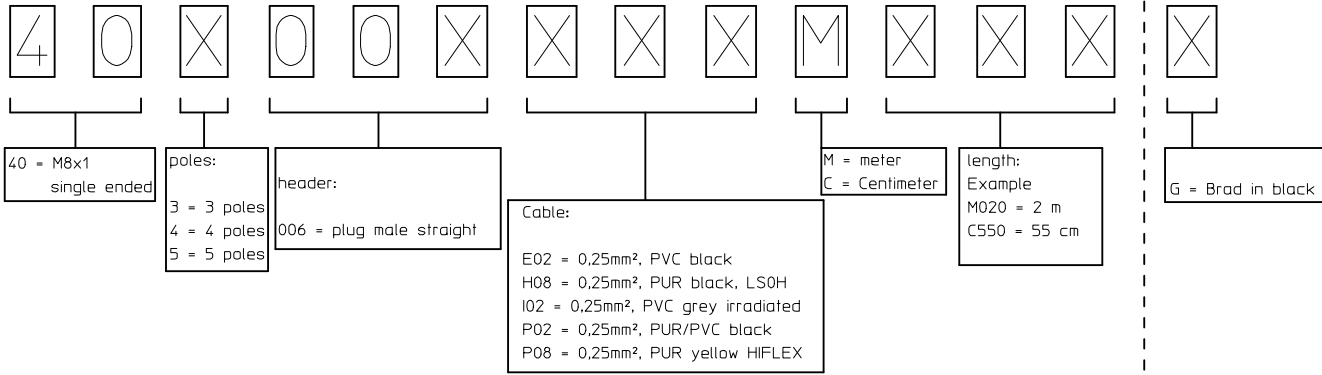

Special Types:

ENTER DESCRIPTION EC NO: IPG2014-1068 DRWN:BBRAUCH 2013/12/09 CHKD: APPR: APOHL 2013/12/09	DESCRIPTION REV	QUALITY SYMBOLS ▽=0 ▽=0	GENERAL TOLERANCES (UNLESS SPECIFIED)		DIMENSION STYLE MM ONLY		SCALE 3:1	DESIGN UNITS METRIC	THIRD ANGLE PROJECTION			
				mm	INCH	DRAWN BY APOHL	DATE 2011/08/24	TITLE CSE M8 XP XC MA STR XM SE UNSH NANO-CHANGE				
			4 PLACES	± ---	± ---	CHECKED BY REISSNER	DATE 2012/01/13					
			3 PLACES	± ---	± ---	APPROVED BY AVOGT		DATE 2012/01/18	MOLEX INCORPORATED DOCUMENT NO. SD-120086-002 SHEET NO. 2 OF 3			
2 PLACES	± ---	± ---	MATERIAL NO. SEE TABLE									
1 PLACE	± 0.3	± ---	ANGULAR ± 1 °		THIS DRAWING CONTAINS INFORMATION THAT IS PROPRIETARY TO MOLEX INCORPORATED AND SHOULD NOT BE USED WITHOUT WRITTEN PERMISSION							
DRAFT WHERE APPLICABLE MUST REMAIN WITHIN DIMENSIONS												

7 6 5 4 3 2 1



PART LIST:

1200868302	403006E02M002
1200270459	403006E02M003
1200868056	403006E02M006
1200270364	403006E02M010
1200868303	403006E02M015
1200868228	403006E02M020
1200868304	403006E02M025
1200868305	403006E02M030
1200271420	403006E02M035
1200271421	403006E02M040
1200868306	403006E02M045
1200270105	403006E02M050
1200271422	403006E02M060
1200868307	403006E02M100
1200868387	403006E02M150
1200868390	403006H08M020
1200868078	403006H08M050
1200868310	403006I02M003
1200868311	403006I02M004
1200868312	403006I02M006
1200868313	403006I02M007
1200868314	403006I02M010
1200868315	403006I02M011
1200868316	403006I02M014
1200868317	403006I02M015
1200868318	403006I02M020
1200868319	403006I02M030
1200868320	403006I02M050
1200868321	403006I02M100
1200868322	403006I02M150
1200271294	403006P02M002G
1200271332	403006P02M003
1200271179	403006P02M004
1200271327	403006P02M005
1200271200	403006P02M006
1200271079	403006P02M010
1200270911	403006P02M020

1200270453	403006P02M040
1200866074	403006P02M050
1200270933	403006P02M100
1200270513	403006P08M030
1200270457	403006P08M200
1200868161	404006E02M010
1200868367	404006E02M015
1200868368	404006E02M020
1200270376	404006E02M050
1200868369	404006E02M100
1200868408	404006H08M003
1200868409	404006H08M010
1200868392	404006H08M020
1200868227	404006H08M050
1200868370	404006I02M003
1200868371	404006P02M004G
1200868372	404006P02M010
1200868373	404006P02M020
1200868374	404006P02M030G
1200868375	404006P02M050
1200868376	404006P02M050G
1200868377	404006P02M100
1200868152	405006E02M010
1200868173	405006E02M020
1200868174	405006E02M050
1200868175	405006E02M100
1200868164	405006E02M300
1200868165	405006E02M500
1200868166	405006E02M600
1200868397	405006H08M020
1200270853	405006P02M004G
1200270588	405006P02M005
1200868087	405006P02M010
1200868182	405006P02M012
1200270752	405006P02M020
1200868031	405006P02M030
1200860586	405006P02M040

1200270657	405006P02M050
1200860587	405006P02M060
1200860588	405006P02M100
1200270877	405006P02C550

ENTER DESCRIPTION
 EC NO: IPG2014-1068
 DRWN:BBRAUCH 2013/12/09
 CHKD:
 APPR:APOHL 2013/12/09
 DESCRIPTION
 REV

QUALITY SYMBOLS
 =0
 =0

GENERAL TOLERANCES (UNLESS SPECIFIED)

	mm	INCH
4 PLACES	± ---	± ---
3 PLACES	± ---	± ---
2 PLACES	± ---	± ---
1 PLACE	± 0.3	± ---

ANGULAR ± 1 °

DRAFT WHERE APPLICABLE
 MUST REMAIN
 WITHIN DIMENSIONS

DIMENSION STYLE
MM ONLY

DRAWN BY DATE
 APOHL 2011/08/24

CHECKED BY DATE
 REISSNER 2012/01/13

APPROVED BY DATE
 AVOGT 2012/01/18

MATERIAL NO.
SEE TABLE

SIZE
 4

SCALE
1:1

DESIGN UNITS
METRIC

THIRD ANGLE PROJECTION

TITLE
**CSE M8 XP XC MA STR XM
 SE UNSH
 NANO-CHANGE**

 **MOLEX INCORPORATED**

DOCUMENT NO. **SD-120086-002**

SHEET NO.
3 OF 3

THIS DRAWING CONTAINS INFORMATION THAT IS PROPRIETARY TO MOLEX INCORPORATED AND SHOULD NOT BE USED WITHOUT WRITTEN PERMISSION

6 5 4 3 2 1