

THIS DRAWING IS UNPUBLISHED. RELEASED FOR PUBLICATION
 © COPYRIGHT - By - ALL RIGHTS RESERVED.

LOC	DIST	REVISONS					
		P	LTR	DESCRIPTION	DATE	DWN	APVD
J	-	A1		REVISED PER ECO-11-005140	30MAR11	RK	HMR

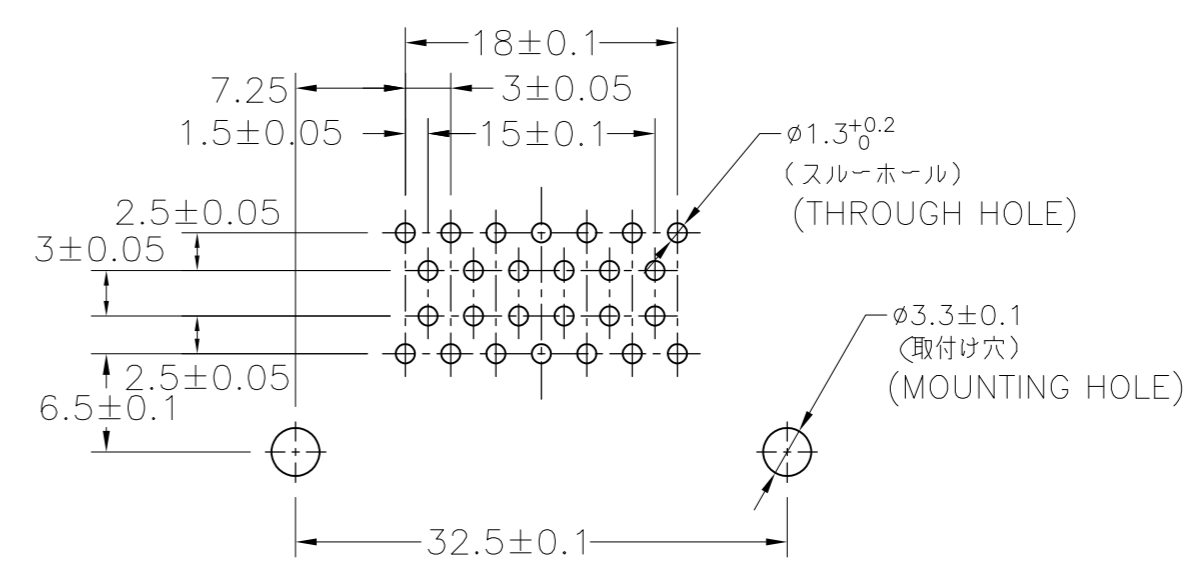

RECOMENDED P.W.B. DIM.
 プリント基板 推奨ホールパターン
 (図は実装面より見た場合)

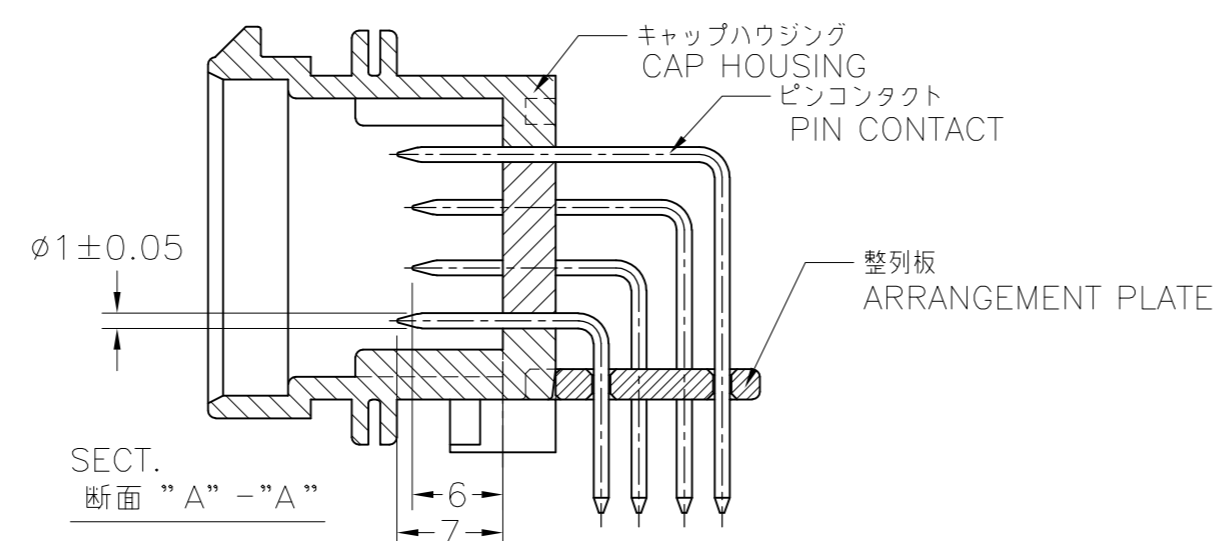
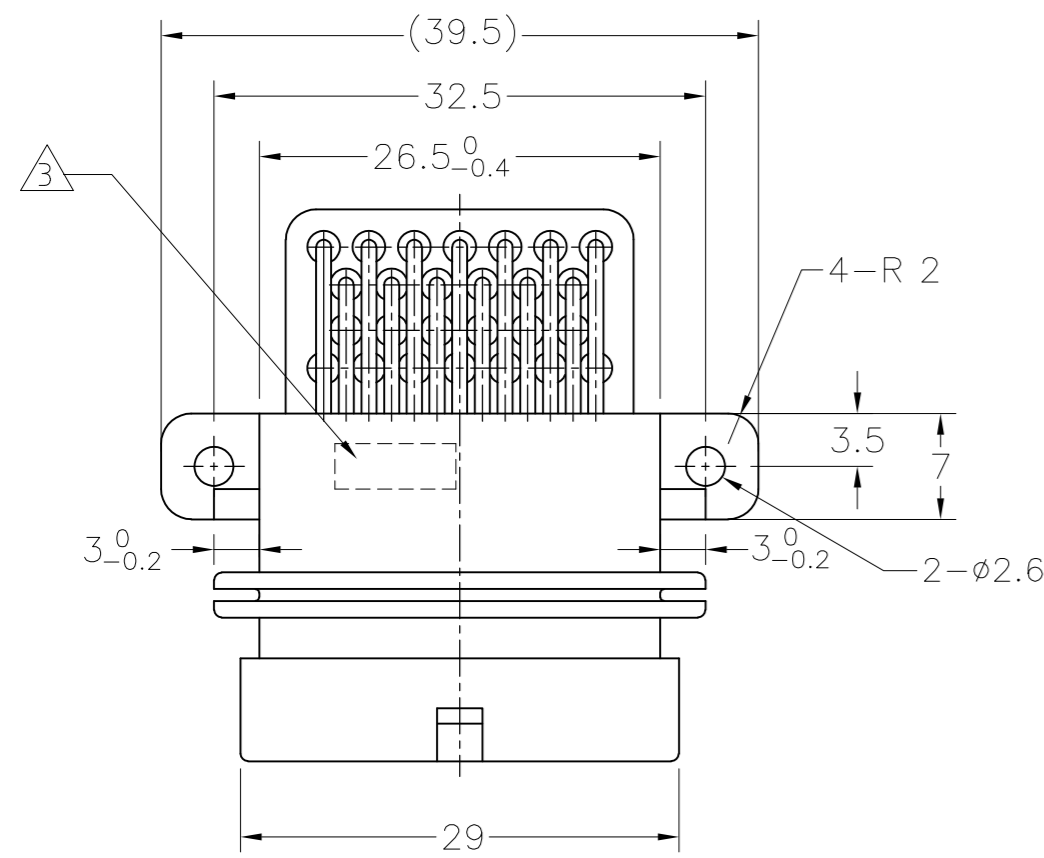
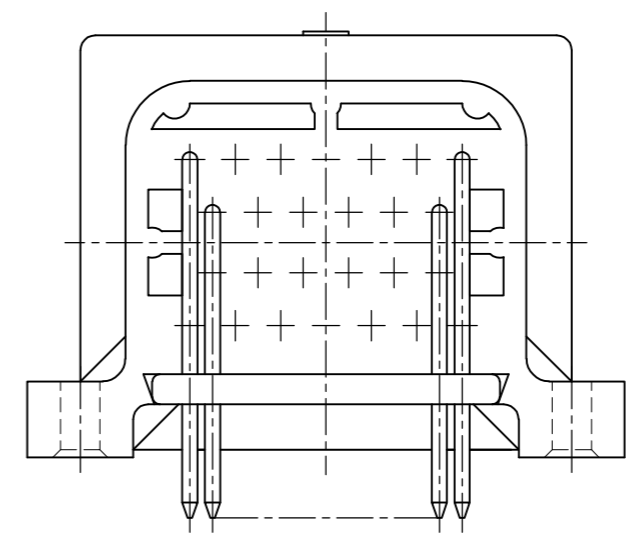
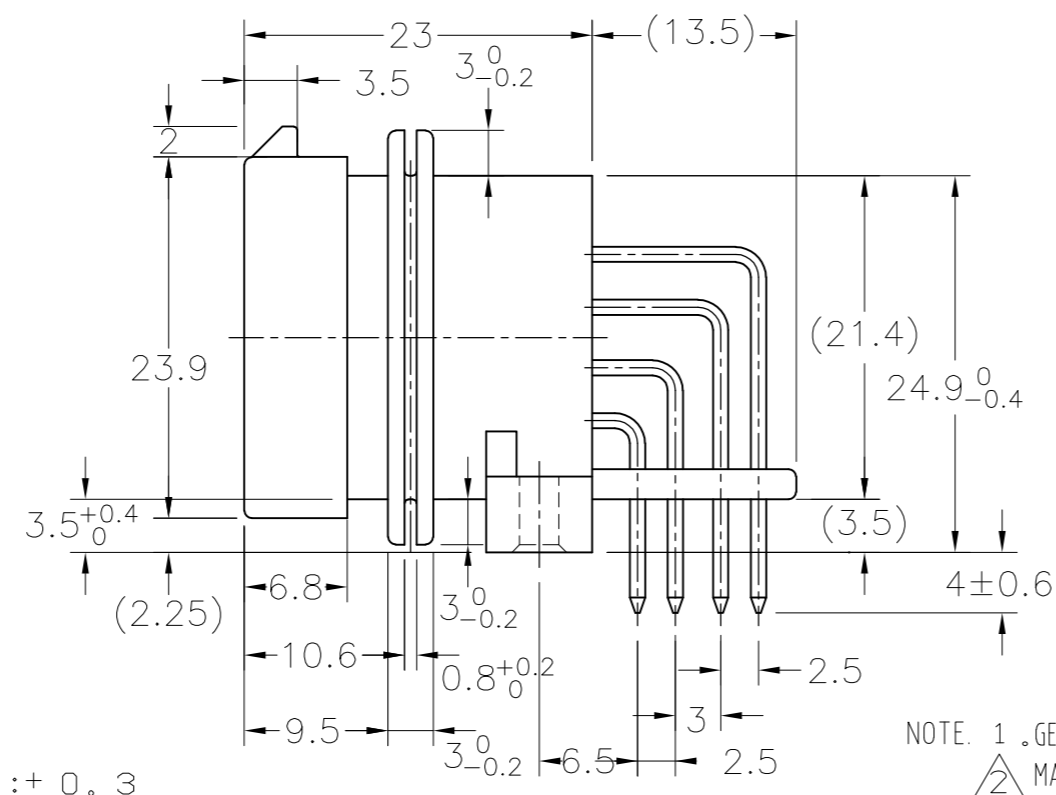
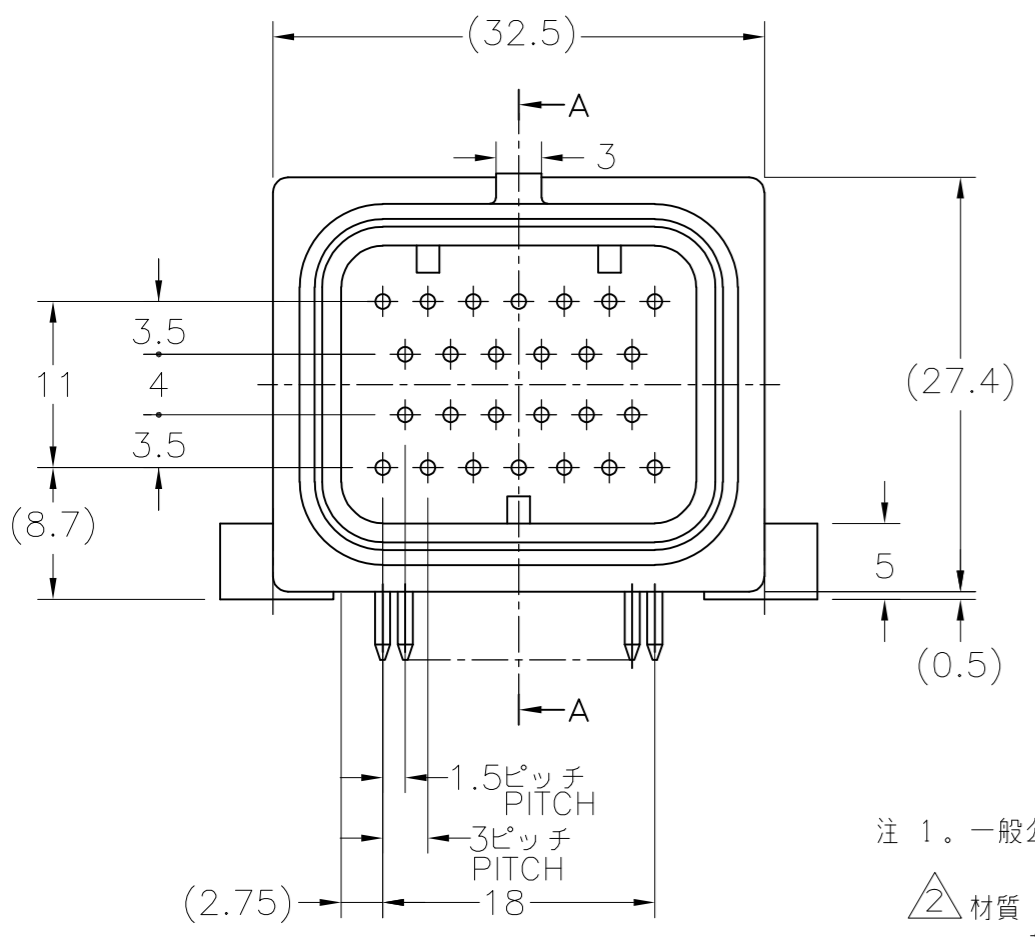

注 1. 一般公差: ±0.3

- △ 材質 キャップハウジング: 熱可塑性ポリエステル樹脂
 整列板: 熱可塑性ポリエステル樹脂
 ピンコンタクト: 黄銅/ニッケル下地、金めっき (接点部)
 はんだめっき (基板側)
- △ 3. 当箇所製造日管理番号(ロット番号)を印字する。
- 4. 基板取付けねじ
 JIS B 1122 十字穴付きタッピングねじ なべ2種 3xL (L=6.5+基板厚)
 先端溝付き及び溝無し (亜鉛メッキ)
 上記以外のねじを使用の場合、別途打ち合わせの事。
- △ 材質 キャップハウジング: 熱可塑性ポリエステル樹脂
 整列板: 熱可塑性ポリエステル樹脂
 ピンコンタクト: 黄銅/ニッケル下地、金めっき (接点部)
 すずめっき (基板側)

6. 嵌合相手型番: TABLE-1 参照

9-6437287-9	3-1437290-8
9-1437287-9	
9-6437287-8	3-1437290-7
9-1437287-8	
PART NUMBER	MATING PLUG ASSEMBLY

TABLE-1

- NOTE. 1. GENERAL TOLERANCE: ±0.3
- △ 2. MATERIAL
 CAP HOUSING: POLYESTER
 ARRANGEMENT PLATE: POLYESTER
 PIN CONTACT: BRASS GOLD PLATING OVER Ni PLATING (CONTACT PART)
 BRASS TIN-LEAD PLATING OVER Ni PLATING (SOLDERING PART)
- △ 3. MANUFACTURED DATE CONTROL NO.(LOT NO.)
 AS FOLLOWING IS INDICATED.
- 4. MOUNTING SCREW
 JIS B 1122 CROSS RECESSED PAN HEAD TAPPING SCREW (ZINC PLATING)
 TYPE 2 3xL (L=6.5xBOARD THICKNESS)
- △ 5. MATERIAL
 CAP HOUSING: POLYESTER
 ARRANGEMENT PLATE: POLYESTER
 PIN CONTACT: BRASS GOLD PLATING OVER Ni PLATING (CONTACT PART)
 BRASS TIN PLATING OVER Ni PLATING (SOLDERING PART)
- 6. PART NUMBER OF PLUG ASSEMBLY TO BE MATED: SEE TABLE-1

9-6437287-9	△ 5	-	-
9-6437287-8	△ 5	-	本 図
6473423-2	△ 5	-	SEE DWG1473423
6473423-1	△ 5	-	SEE DWG1473423
OBSOLETE	△ 2	1473423-2	SEE DWG1473423
OBSOLETE	△ 2	1473423-1	SEE DWG1473423
OBSOLETE	△ 2	9-1437287-9	3900134-2612
OBSOLETE	△ 2	9-1437287-8	3900134-2611

Part No. 型番	Old Part No. 旧型番	REMARK 備考
----------------	---------------------	--------------

9-1437287-9, 9-6437287-9
 (3900134-2612)

THIS DRAWING IS A CONTROLLED DOCUMENT.

DWN (A.ISHIJIMA)	100CT00	TE Connectivity SUPER SEAL CONNECTOR (UPPER LOCK) CAP HOUSING 26POS. ASS'Y
CHK K. SHINADA	100CT00	
APVD K. SHINADA	100CT00	
NAME 名称		
DIMENSIONS: 単位: 純 mm	TOLERANCES UNLESS OTHERWISE SPECIFIED: 一般公差	PRODUCT SPEC 製品規格 108-78140
0 PLC ± -	1 PLC ± -	APPLICATION SPEC 取付適用規格
2 PLC ± -	3 PLC ± -	SCALE 2:1
4 PLC ± -	ANGLES ± -	SHEET 1 of 3
MATERIAL 材料 SEE TABLE	FINISH 仕上 -	WEIGHT -
CUSTOMER DRAWING		REV A1

C3900134

9-1437287-8

A

A

THIS DRAWING IS UNPUBLISHED. RELEASED FOR PUBLICATION
 © COPYRIGHT - By - ALL RIGHTS RESERVED.

LOC	DIST	REVISONS				
		P	LTR	DATE	DWN	APVD
J	-	-	-	-	-	-
SEE SHEET 1						

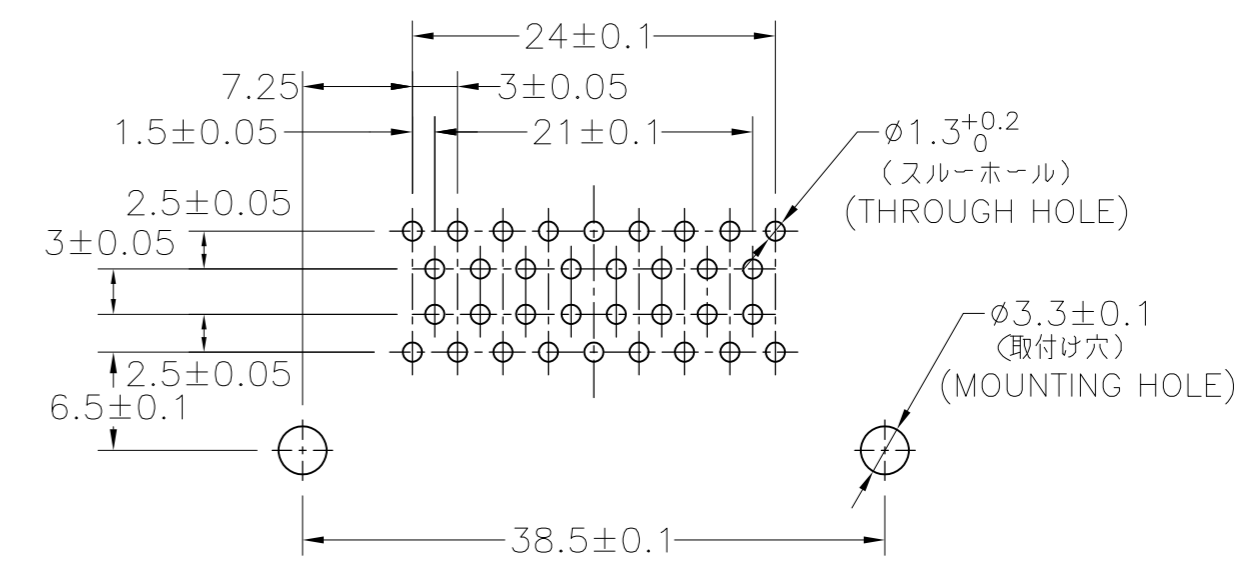
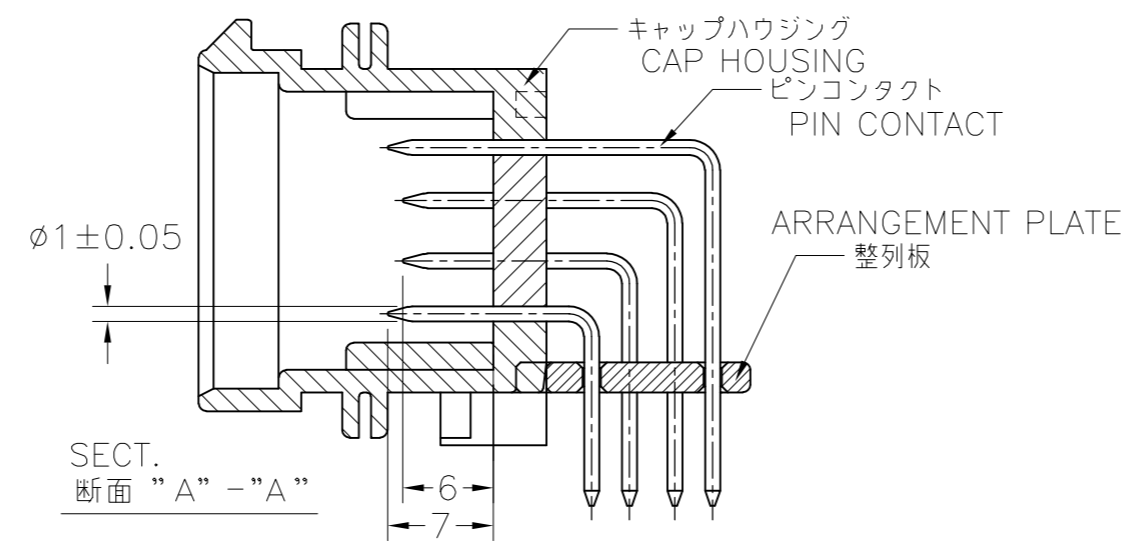
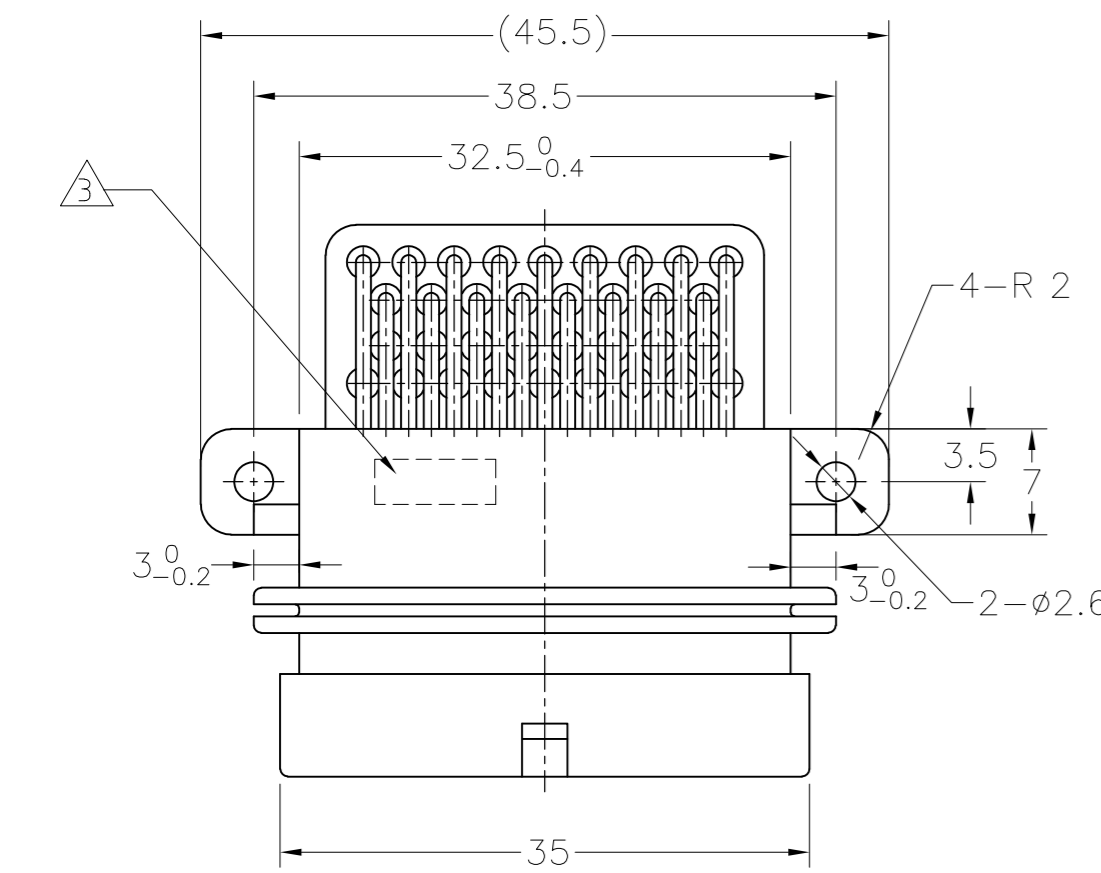

RECOMENDED P.W.B. DIM.
 プリント基板 推奨ホールパターン
 (図は実装面より見た場合)

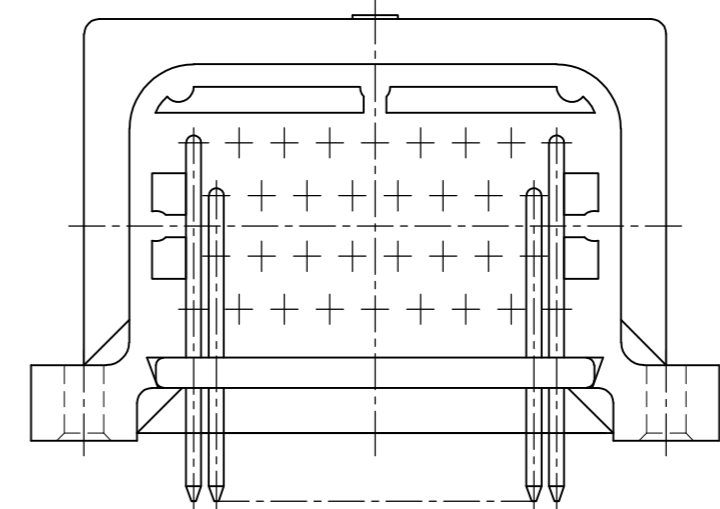
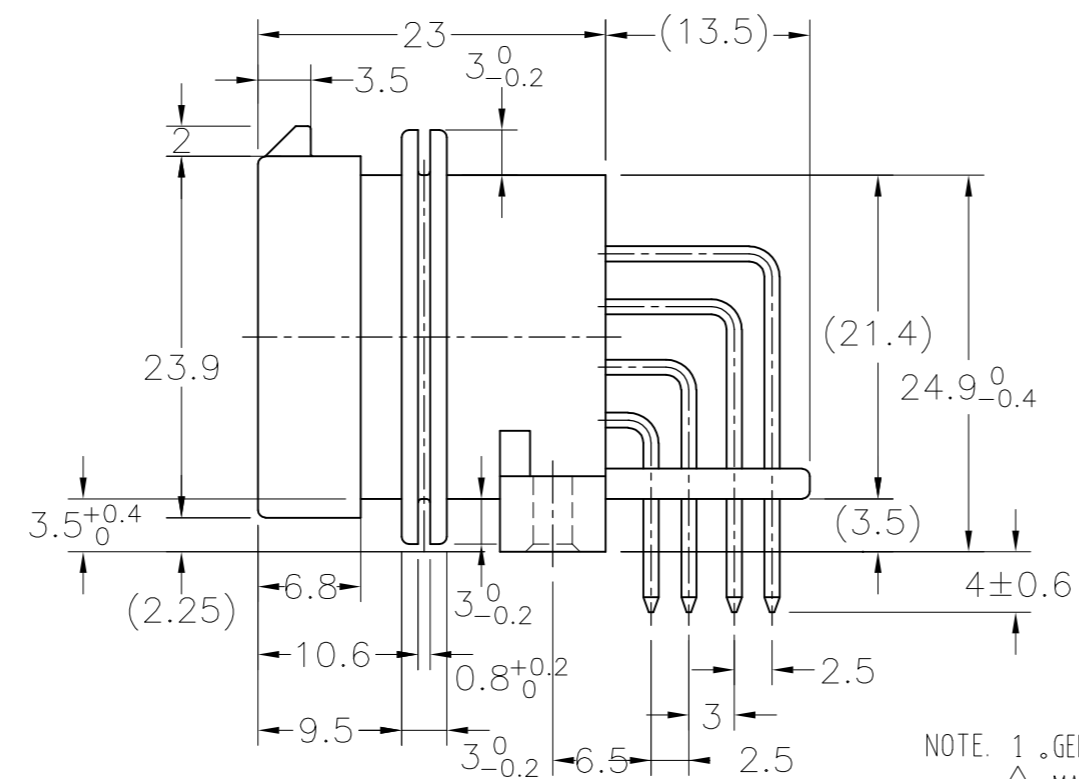
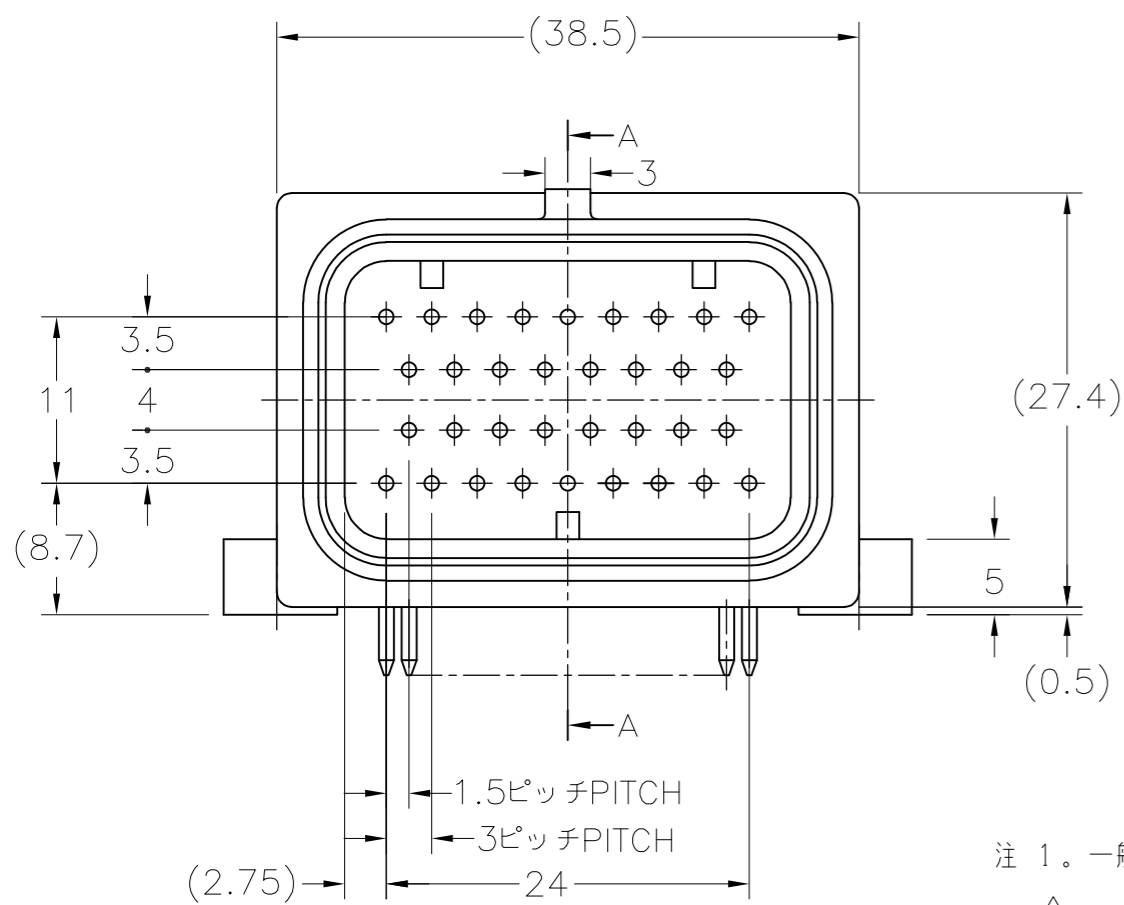

注 1. 一般公差: ±0.3

NOTE 1. GENERAL TOLERANCE: ±0.3

- ② 材質 キャップハウジング: 熱可塑性ポリエステル樹脂
 整列板: 熱可塑性ポリエステル樹脂
 ピンコンタクト: 黄銅/ニッケル下地、金めっき (接点部)
 はんだめっき (基板側)
- ③ 当箇所製造日管理番号(ロット番号)を印字する。
- 4. 基板取付けねじ
 JIS B 1122 十字穴付きタッピンねじ なべ2種 3xL (L=6.5+基板厚)
 先端溝付き及び溝無し (亜鉛メッキ)
 上記以外のねじを使用の場合、別途打ち合わせの事。
- ⑤ 材質 キャップハウジング: 熱可塑性ポリエステル樹脂
 整列板: 熱可塑性ポリエステル樹脂
 ピンコンタクト: 黄銅/ニッケル下地、金めっき (接点部)
 すずめっき (基板側)
- 6. 嵌合相手型番: TABLE-1 参照

- ② MATERIAL
 CAP HOUSING: POLYESTER
 ARRANGEMENT PLATE: POLYESTER
 PIN CONTACT: BRASS GOLD PLATING OVER Ni PLATING (CONTACT PART)
 BRASS TIN-LEAD PLATING OVER Ni PLATING (SOLDERING PART)
- ③ MANUFACTURED DATE CONTROL NO.(LOT NO.)
 AS FOLLOWING IS INDICATED.
- 4. MOUNTING SCREW
 JIS B 1122 CROSS RECESSED PAN HEAD TAPPING SCREW (ZINC PLATING)
 TYPE 2 3xL (L=6.5xBOARD THICKNESS)
- ⑤ MATERIAL
 CAP HOUSING: POLYESTER
 ARRANGEMENT PLATE: POLYESTER
 PIN CONTACT: BRASS GOLD PLATING OVER Ni PLATING (CONTACT PART)
 BRASS TIN PLATING OVER Ni PLATING (SOLDERING PART)
- 6. PART NUMBER OF PLUG ASSEMBLY TO BE MATED: SEE TABLE-1

6437288-2	4-1437290-1
1437288-2	
6437288-1	4-1437290-0
1437288-1	
PART NUMBER	MATING PLUG ASSEMBLY

TABLE-1

	6437288-2	⑤	-	
	6437288-1	⑤	-	本図
OBSOLETE	1437288-2	②	3900134-3412	
OBSOLETE	1437288-1	②	3900134-3411	本図
Part No.	Old Part No.	REMARK		
型番	旧型番	備考		

THIS DRAWING IS A CONTROLLED DOCUMENT.		DWN	-	TE Connectivity	
DIMENSIONS: 単位: 寸 mm		CHK	-		
TOLERANCES UNLESS OTHERWISE SPECIFIED 一般公差		APVD	-	NAME 名称	
0 PLC ±		PRODUCT SPEC 製品規格		SUPERSEAL コネクタ(上ロック) キャップハウジング 34極 ASS'Y	
1 PLC ±		APPLICATION SPEC 取付適用規格		SUPER SEAL CONNECTOR (UPPER LOCK)	
2 PLC ±		WEIGHT		CAP HOUSING 34POS. ASS'Y	
3 PLC ±		SCALE 2:1		DRAWING NO. 番号	
4 PLC ±		SHEET 2 of 3		RESTRICTED TO	
ANGLES ±		CUSTOMER DRAWING		C=9-1437287-8	
FINISH 仕上		REV A1			

C3900134

9-1437287-8

A

A

THIS DRAWING IS UNPUBLISHED. RELEASED FOR PUBLICATION
 © COPYRIGHT - By - ALL RIGHTS RESERVED.

LOC	DIST	REVISONS				
J	-	P	LTR	DATE	DWN	APVD
		DESCRIPTION				
		SEE SHEET 1				

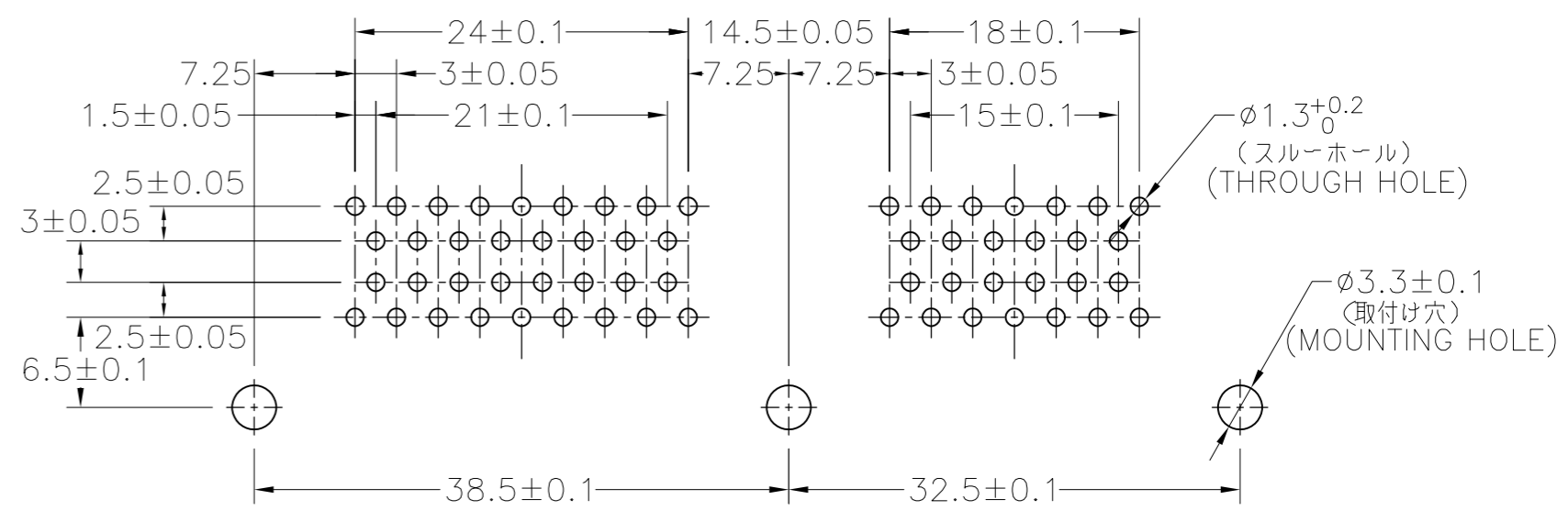
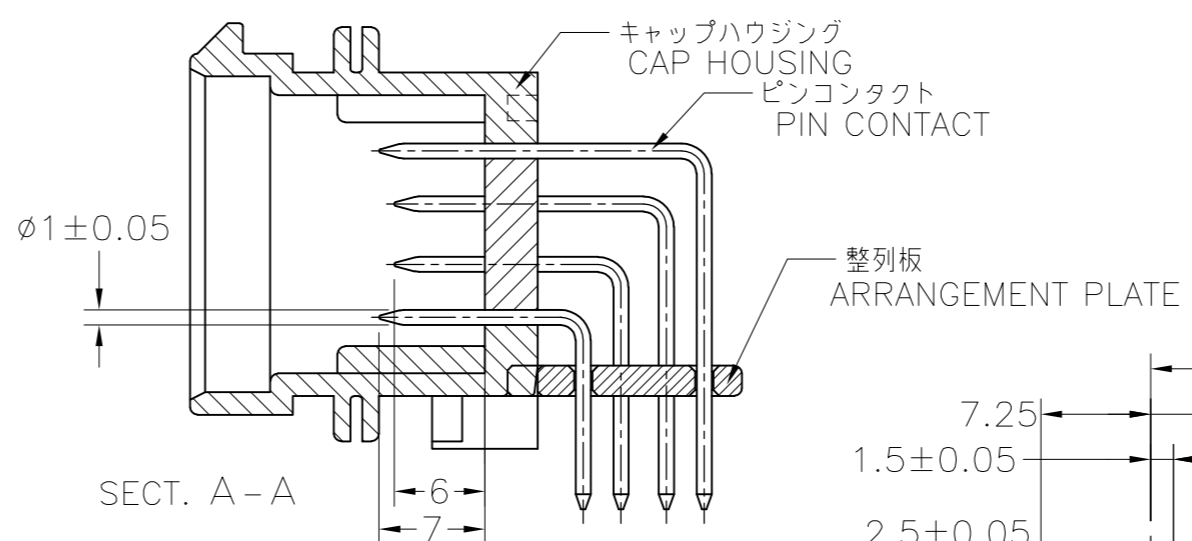
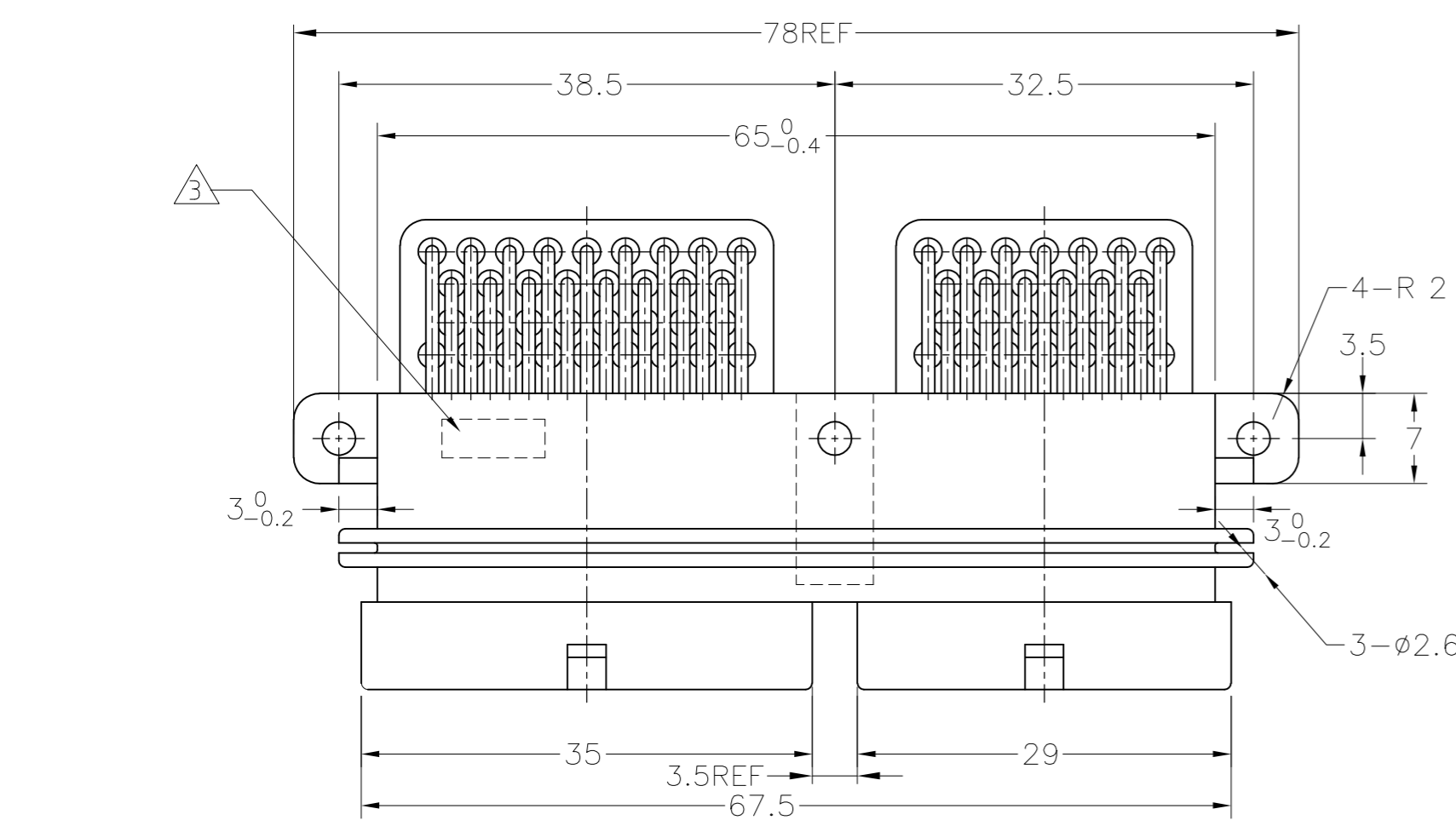

RECOMENDED P.W.B. DIM.
 プリント基板 推奨ホールパターン
 (図は実装面より見た場合)

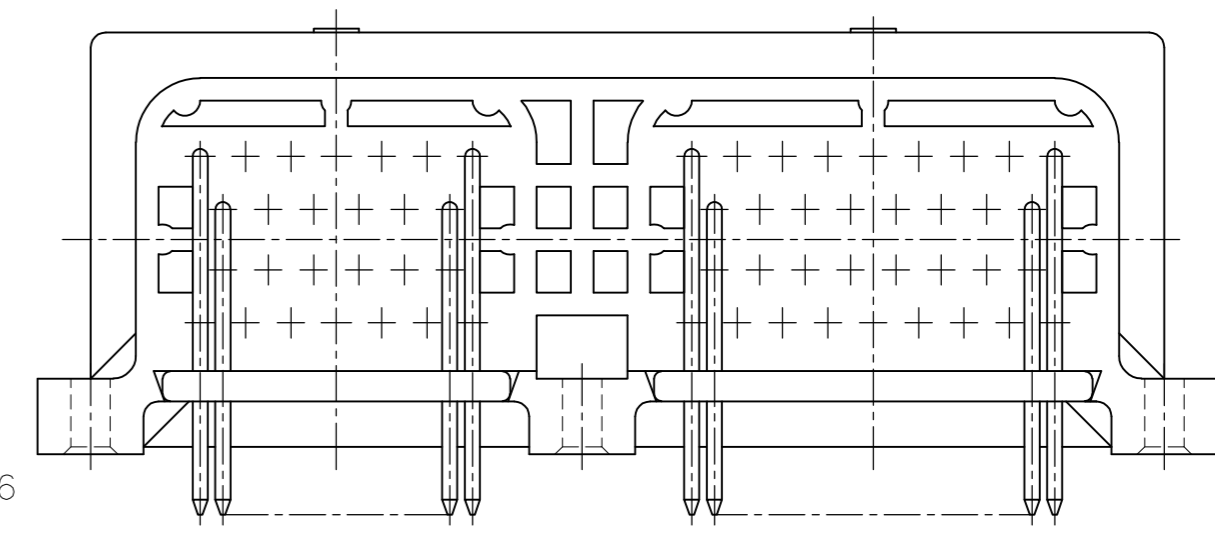
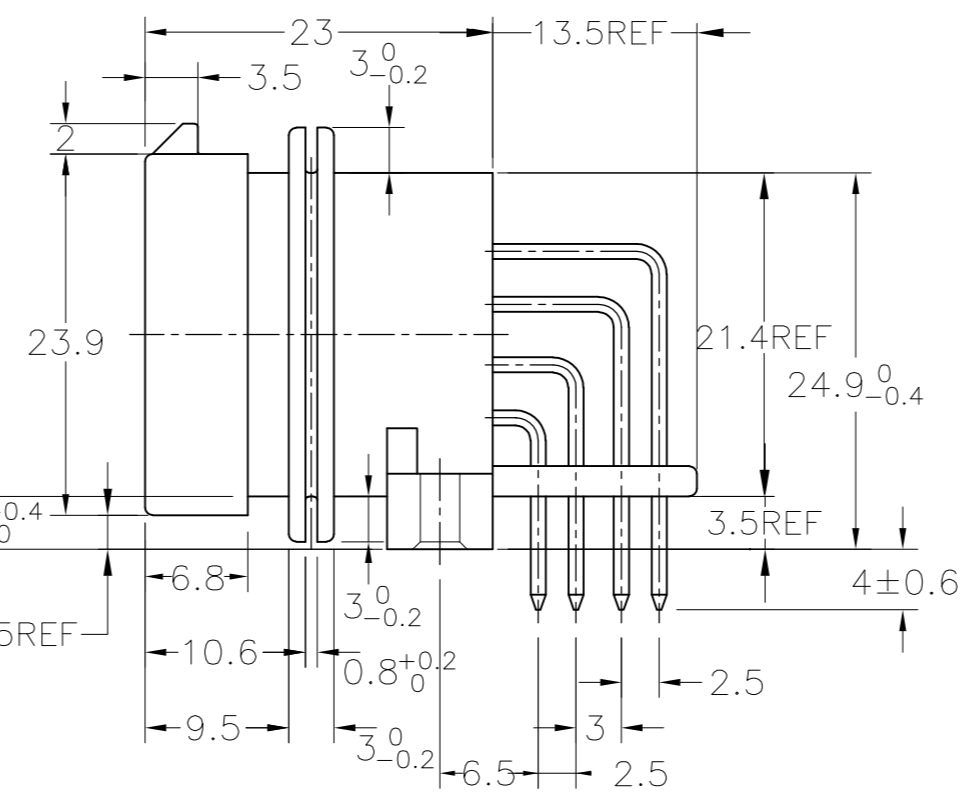
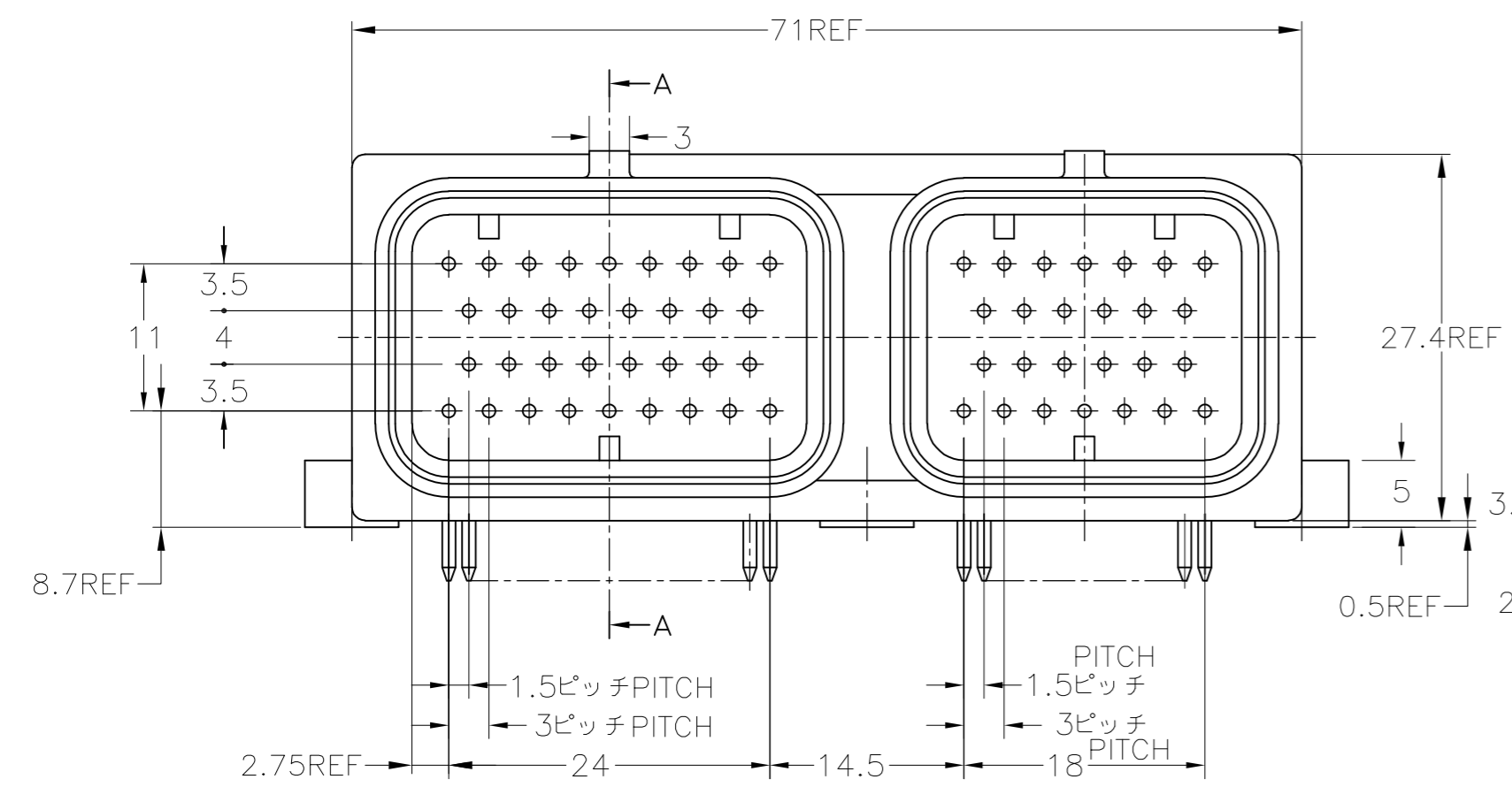

注 1. 一般公差: ±0.3

NOTE 1. GENERAL TOLERANCE: ±0.3

- △ 材質 キャップハウジング: 熱可塑性ポリエステル樹脂
 整列板: 熱可塑性ポリエステル樹脂
 ピンコンタクト: 黄銅/ニッケル下地、金めっき (接点部)
 はんだめっき (基板側)
- △ 当箇所にて製造日管理番号(ロット番号)を印字する。
- 4. 基板取付けねじ
 JIS B 1122 十字穴付きタッピンねじ なべ2種 3xL (L=6.5+基板厚)
 先端溝付き及び溝無し (亜鉛メッキ)
 上記以外のねじを使用の場合、別途打ち合わせの事。
- △ 材質 キャップハウジング: 熱可塑性ポリエステル樹脂
 整列板: 熱可塑性ポリエステル樹脂
 ピンコンタクト: 黄銅/ニッケル下地、金めっき (接点部)
 すずめっき (基板側)

- △ MATERIAL
 CAP HOUSING: POLYESTER
 ARRANGEMENT PLATE: POLYESTER
 PIN CONTACT: BRASS GOLD PLATING OVER Ni PLATING (CONTACT PART)
 BRASS TIN-LEAD PLATING OVER Ni PLATING (SOLDERING PART)
- △ MANUFACTURED DATE CONTROL NO.(LOT NO.)
 AS FOLLOWING IS INDICATED.
- 4. MOUNTING SCREW
 JIS B 1122 CROSS RECESSED PAN HEAD TAPPING SCREW (ZINC PLATING)
 TYPE 2 3xL (L=6.5xBOARD THICKNESS)
- △ MATERIAL
 CAP HOUSING: POLYESTER
 ARRANGEMENT PLATE: POLYESTER
 PIN CONTACT: BRASS GOLD PLATING OVER Ni PLATING (CONTACT PART)
 BRASS TIN PLATING OVER Ni PLATING (SOLDERING PART)

6. PART NUMBER OF PLUG ASSEMBLY TO BE MATED: SEE TABLE-1

6437288-3	3-1437290-7 (26Pos.)
1437288-3	4-1437290-0 (34Pos.)
PART NUMBER	MATING PLUG ASSEMBLY

TABLE-1

6473427-1	△5	-	SEE DWG1473427
6437288-3	△5	-	本図
OBSOLETE	1473427-1	△2	SEE DWG1473427
OBSOLETE	1437288-3	△2	3900134-6011 本図
Part No. 型番	Old Part No. 旧型番	REMARK 備考	

THIS DRAWING IS A CONTROLLED DOCUMENT.		DWN	100CT00		SUPERSEAL コネクタ(上ロック) キャップハウジング 60極 ASS'Y SUPER SEAL CONNECTOR (UPPER LOCK) CAP HOUSING 60POS. ASS'Y
DIMENSIONS: 単位: 概 mm		CHK	100CT00		
TOLERANCES UNLESS OTHERWISE SPECIFIED: 一般公差		APVD	100CT00		
0 PLC ± 1 PLC ± 2 PLC ± 3 PLC ± 4 PLC ± ANGLES ±		PRODUCT SPEC	108-78140		
MATERIAL 材料	SEE TABLE	FINISH 仕上	-	WEIGHT	-
CUSTOMER DRAWING		SCALE	2:1	SHEET	3 OF 3

C3900134

9-1437287-8