

PRODUCT NUMBER	PLATING OPT.	HSG COLOR OPT.
10112633-101	OPTION 1	BLACK
10112633-101LF	OPTION 2	BLACK
10112633-121	OPTION 1	NATURAL
10112633-121LF	OPTION 2	NATURAL

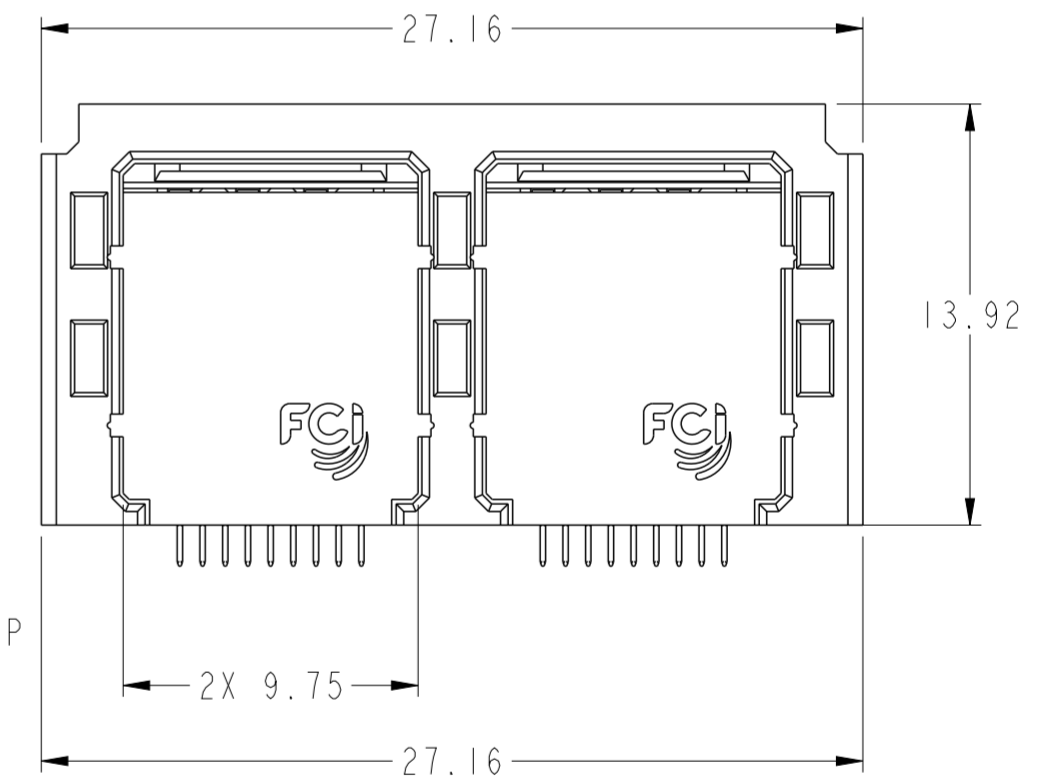
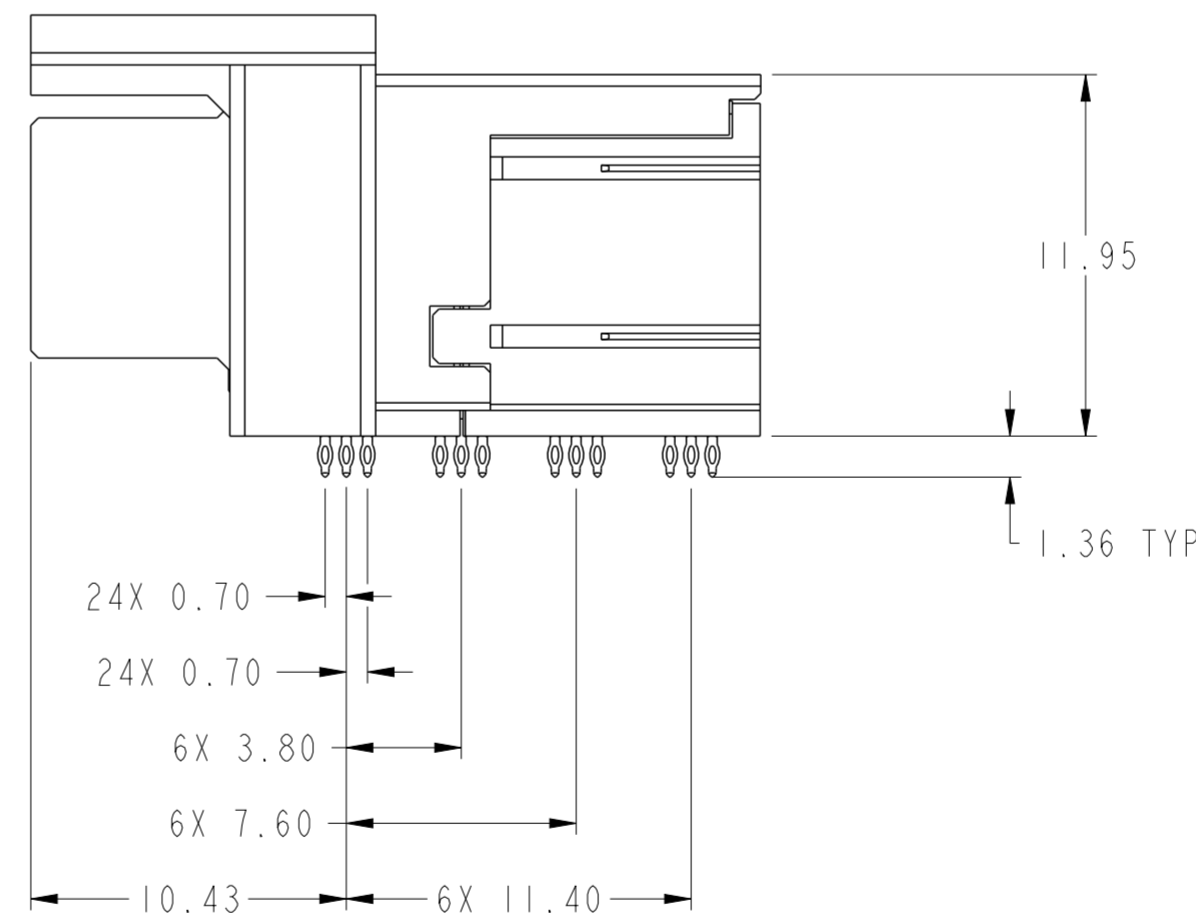
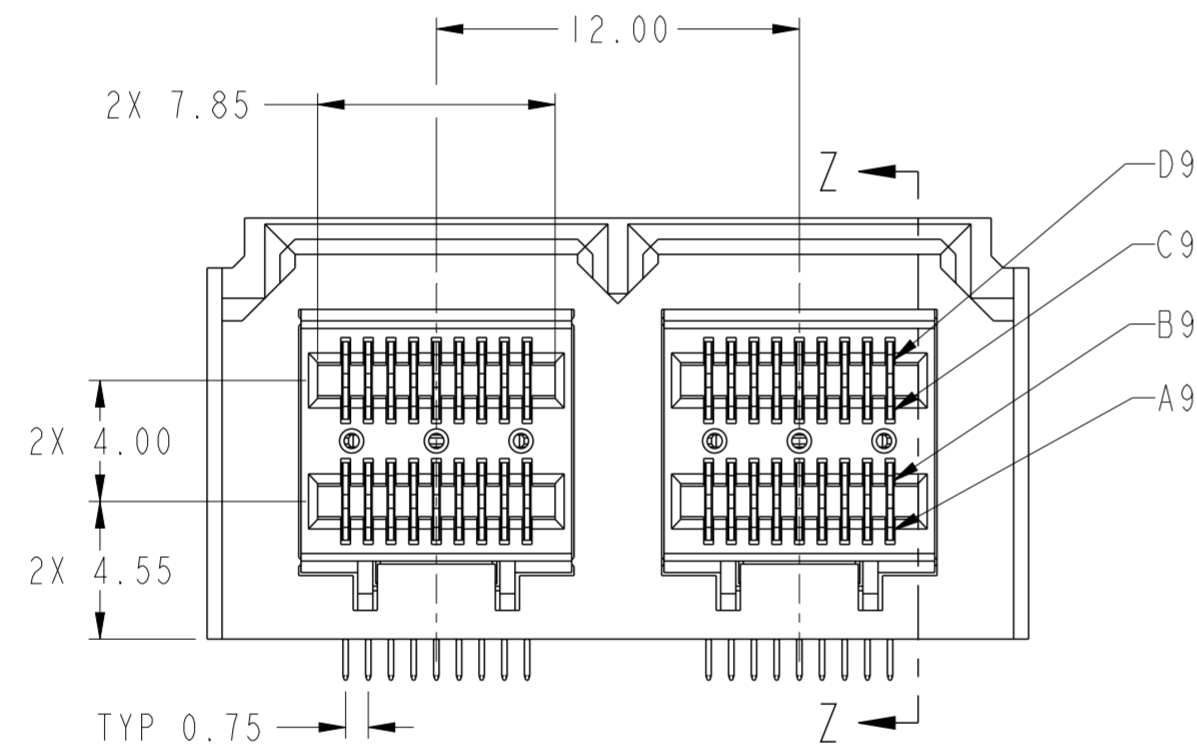
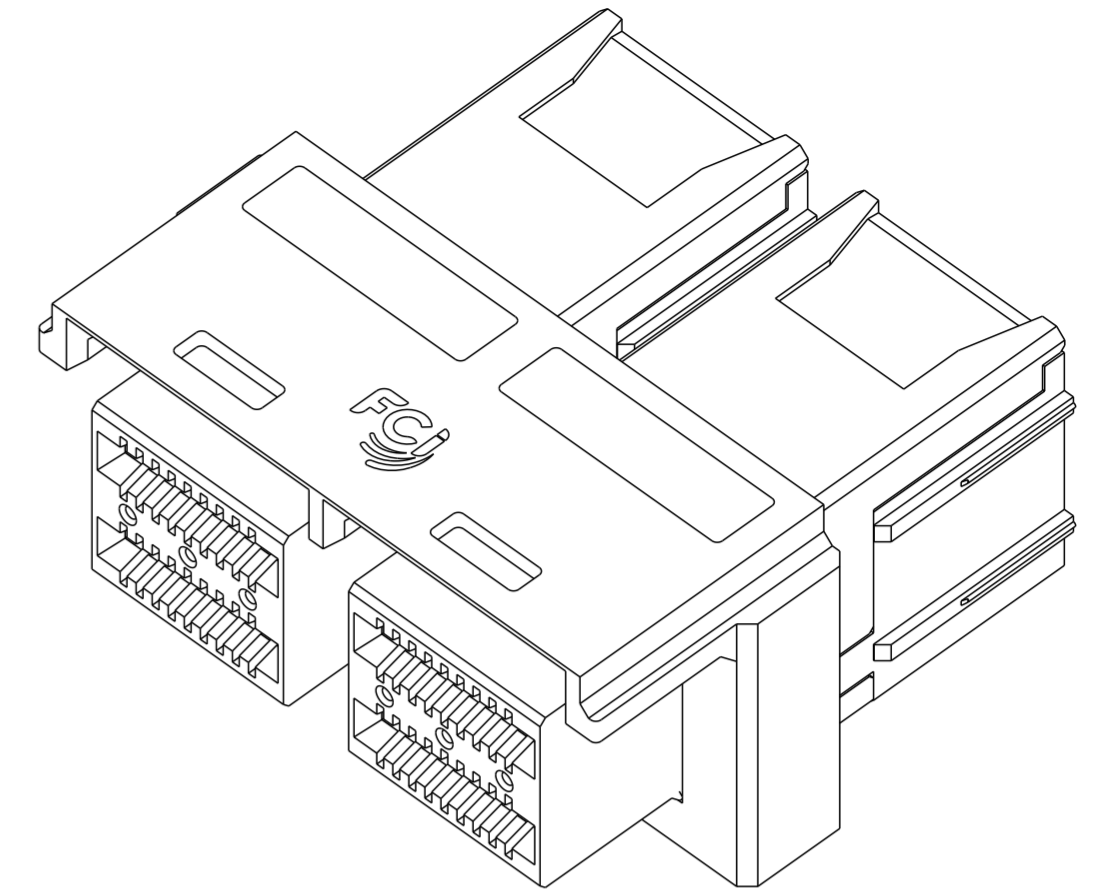
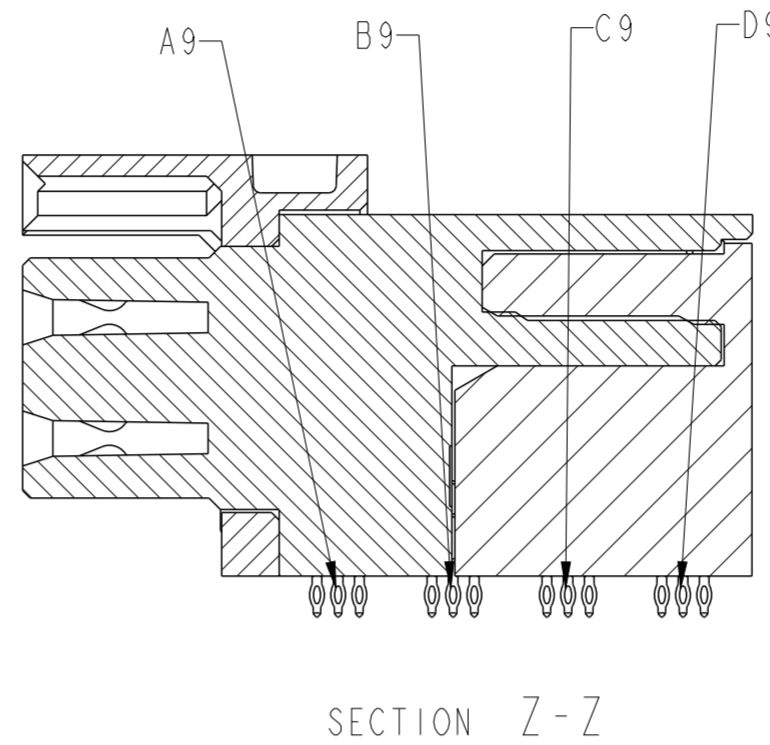
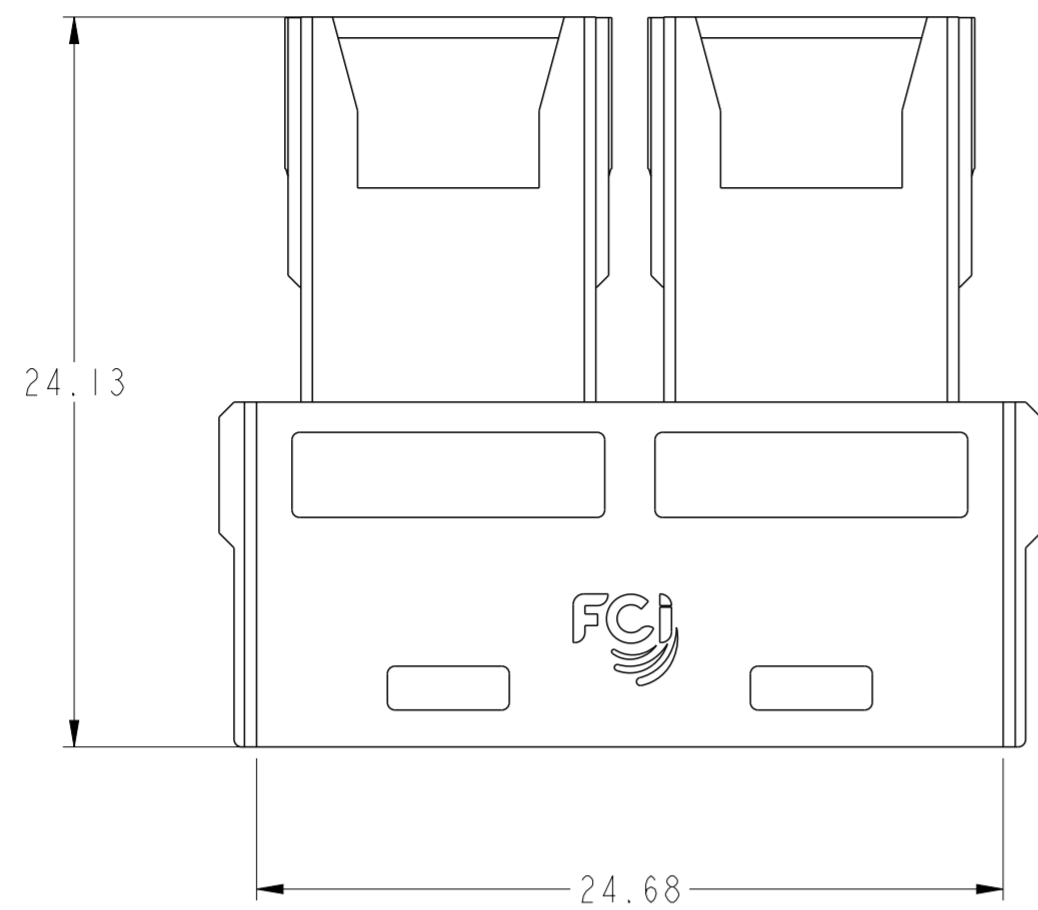

NOTES:

- MATERIALS:  
CONNECTOR HOUSING: HIGH TEMPERATURE THERMOPLASTIC  
GLASS FILLED, UL 94V-0  
TERMINALS: COPPER ALLOY
- FINISHES:  
CONTACT AREA: 0.76µm GOLD OVER 2.54µm MIN NICKEL  
TAIL AREA:  
OPTION 1: 0.76µm - 1.52µm TIN/LEAD (90/10) OVER 2.54µm MIN NICKEL.  
OPTION 2: 0.76µm - 1.52µm TIN (LEAD FREE) OVER 2.54µm MIN NICKEL.
- PRODUCT SPECIFICATION: GS-12-650.  
APPLICATION SPECIFICATION: GS-20-0356
- MOUNTING HARDWARE: M2 X 0.4 SELF-THREADING SCREW  
MOUNTING SCREW LENGTH: PCB THICKNESS + 2.5mm MAX.
- THIS CONNECTOR IS DESIGNED TO MEET THE REQUIREMENTS OF INDUSTRY SPECIFICATION SFF-8643.
- A  $\triangle$  SYMBOL WILL BE NEXT TO ANY DIMENSION, VIEW, OR NOTE THAT HAS BEEN MODIFIED WITH THE CURRENT DRAWING REVISION.

MATES WITH MINI-SAS HD ENDS IN:
10119217 SERIES (4i)
10119312 SERIES (4i)
10120086 SERIES (4i)
10120087 SERIES (4i)
10119576 SERIES (8i)
10119577 SERIES (8i)
10120088 SERIES (8i)
10120089 SERIES (8i)

spec ref	-	dr	Mark Gray	2010/08/04	projection	MM	size	A2	scale	4:1	
tolerance std	ASME Y14.5	eng	Qin De-Feng	2014/04/06			ecn no	ELX-DG-17378-1			
		chr	-	rel level				Released			
		appr	Pei-Ming Zheng	2014/04/07	product family	MINI-SAS HD	rel level	Released			
surface	✓	linear	0.X	±0.25		title IX2 INTERNAL ASSEMBLY MINI-SAS HD	dwg no 10112633	rev B	Product - Customer Draw		
		angular	0°	±1/2°					cat. no.	Product - Customer Draw	sheet 1 of 4

# RECOMMENDED BOARD LAYOUT

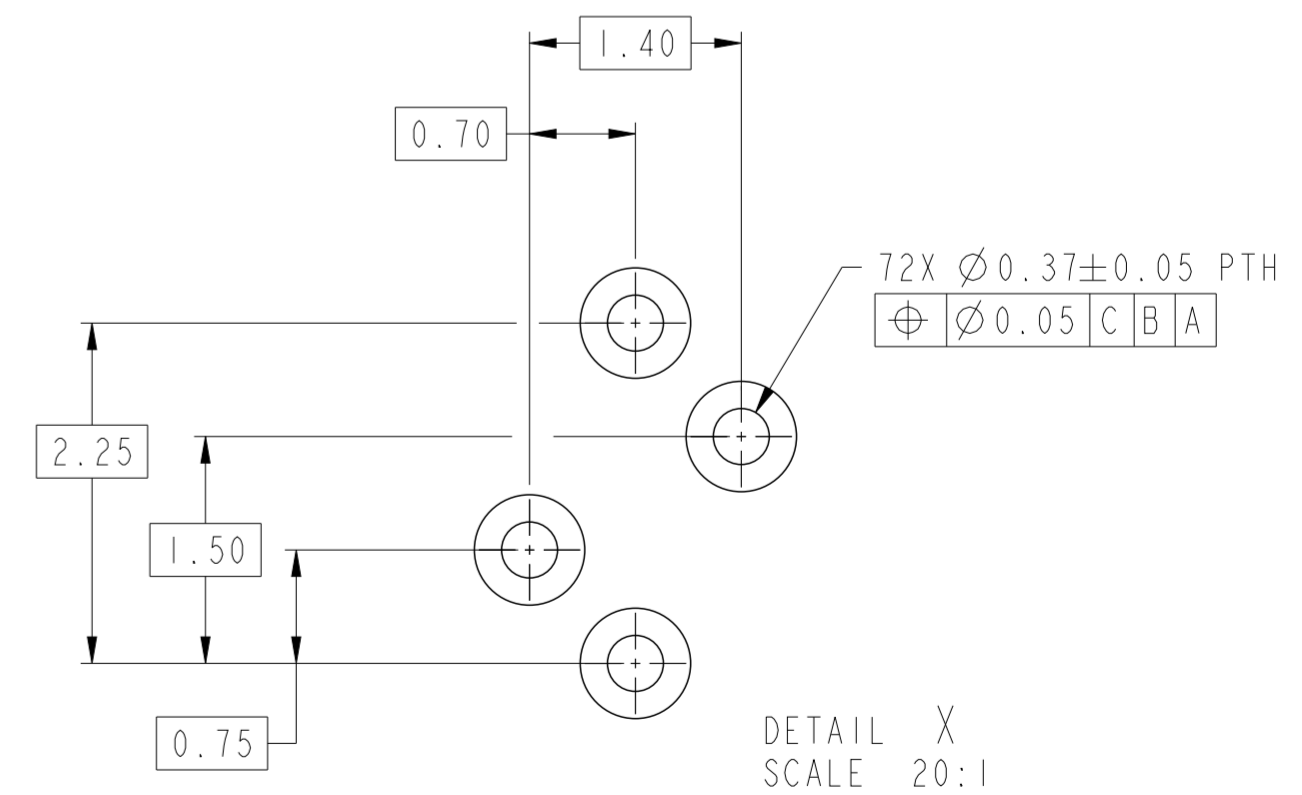
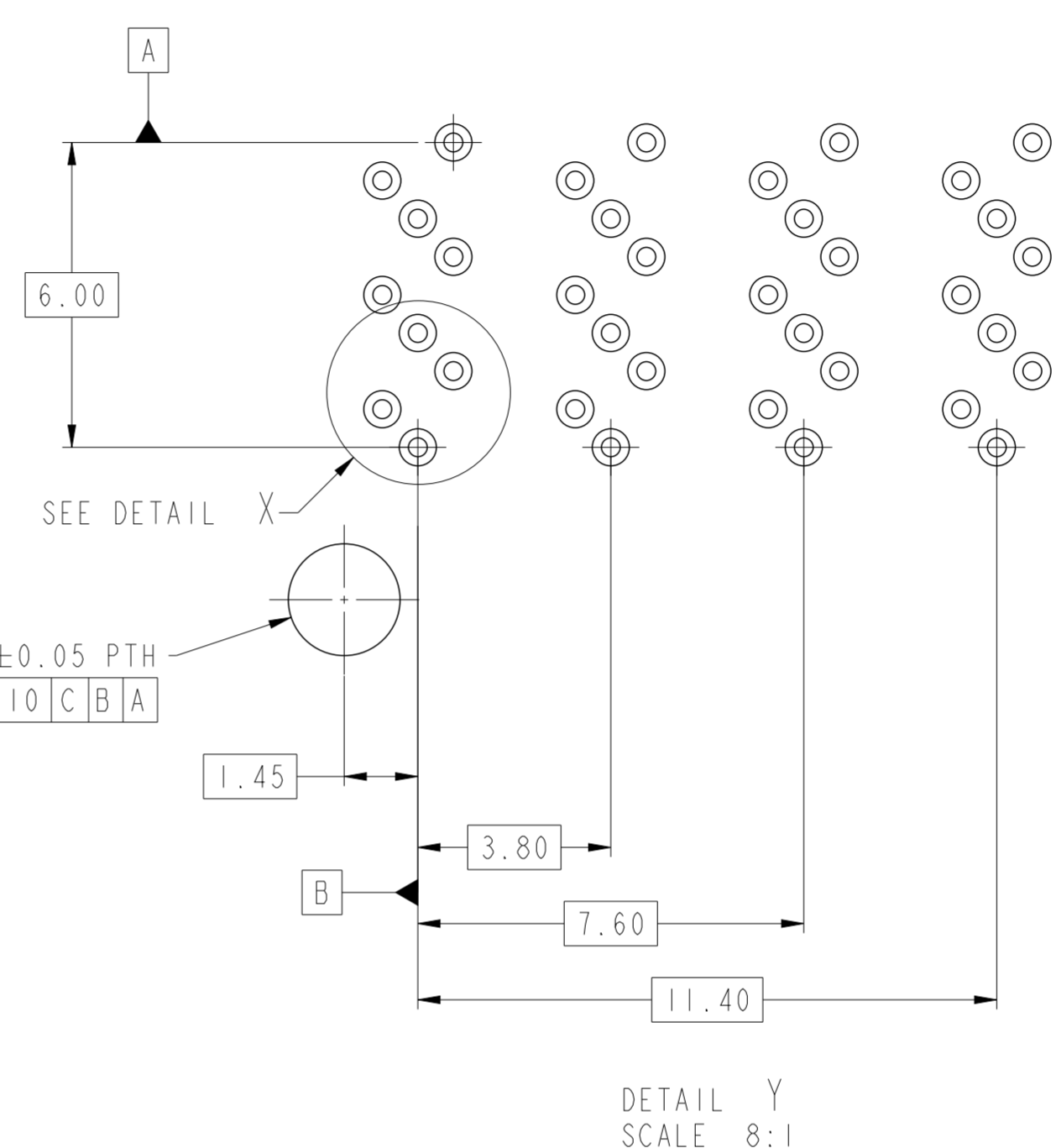
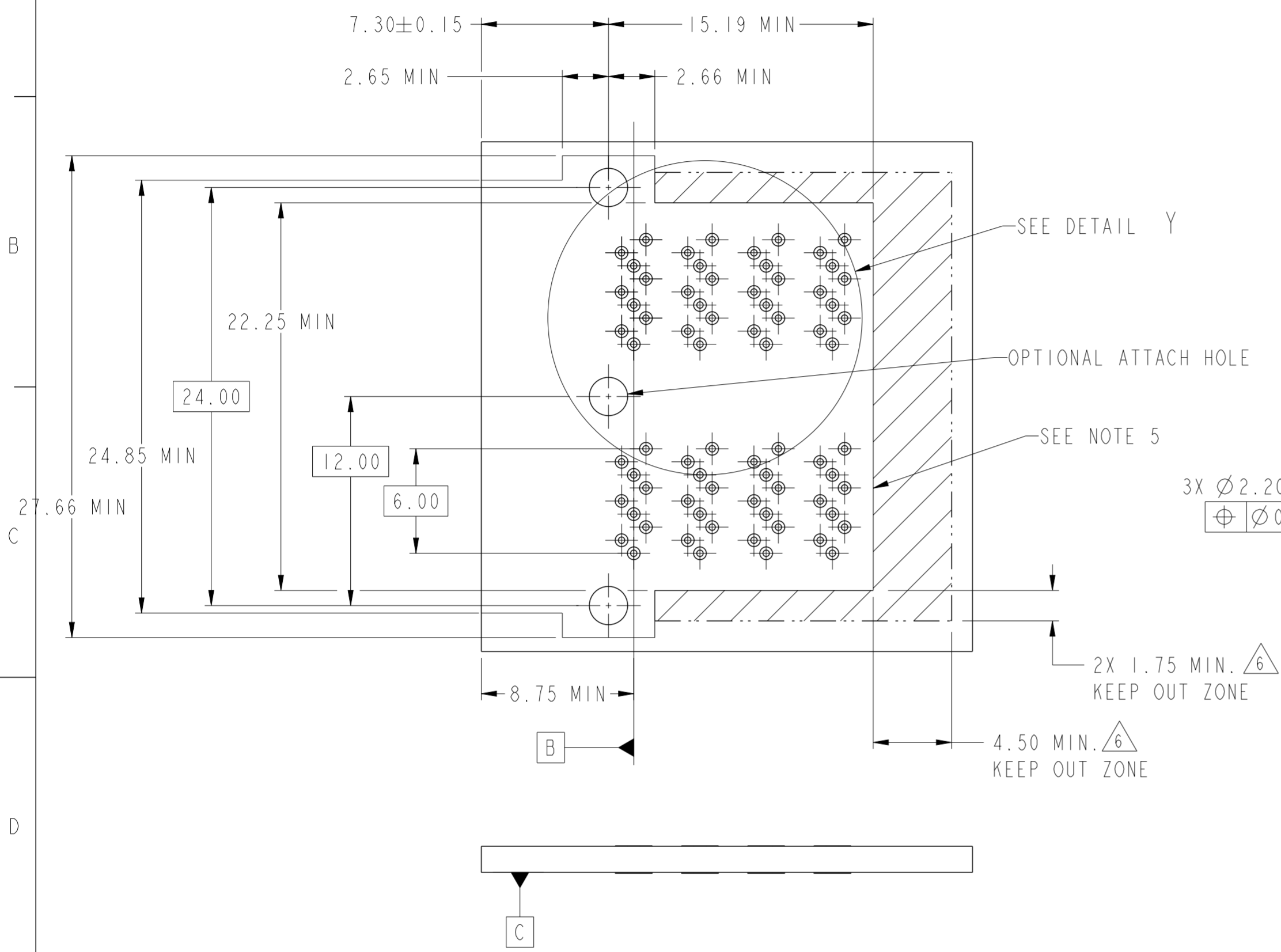

## NOTES:

1. RECOMMENDED DRILL SIZE FOR A Ø0.37 FINISHED PTH IS Ø0.457 (#77 DRILL).
2. RECOMMENDED ANNULAR RING AROUND Ø0.37 FINISHED PTH IS Ø0.73.
3. MINIMUM RECOMMENDED SPACING : 14.00mm.
4. MINIMUM PCB THICKNESS : 1.57mm.
5. CONNECTOR KEEP OUT AREA.

spec ref	-	dr	Mark Gray	2010/08/04	projection	MM	size	A2	scale	2:1
tolerance std	ASME Y14.5	eng	Qin De-Feng	2014/04/06	chr	-	ecn no	ELX-DG-17378-1	rel level	Released
surface	✓	appr	Pei-Ming Zheng	2014/04/07	product family	MINI-SAS HD	cat. no.	10112633	rev	B
ASME Y14.5	linear	0.X	±0.25	0.XX	±0.13	0.XXX	±	angular	0°	±1/2°

Copyright FCI. FCI

# PIN OUT DESIGNATIONS

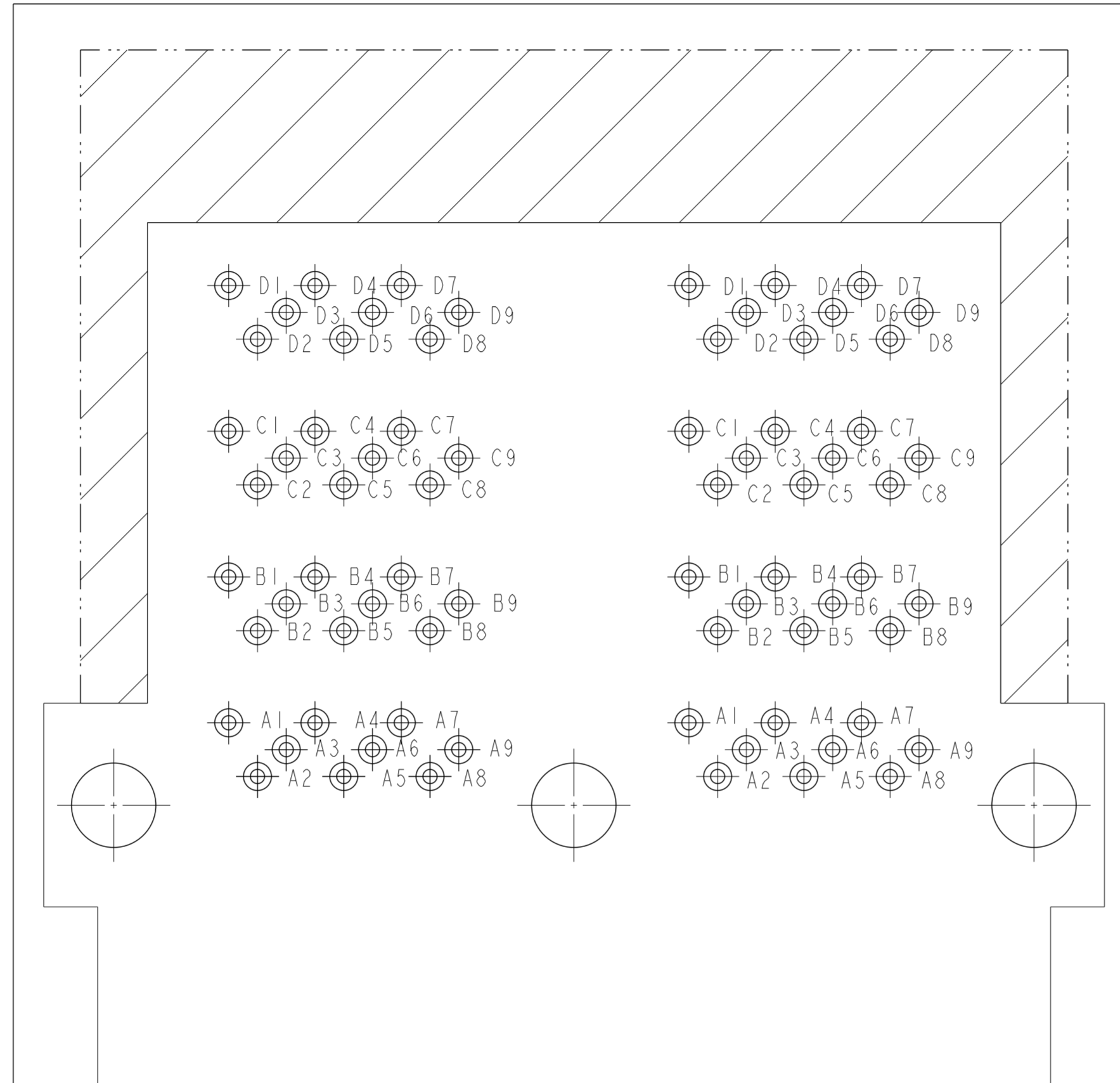

spec ref	-	dr	Mark Gray	2010/08/04	projection	MM	size	A2	scale	2:1																							
tolerance std	ASME Y14.5	eng	Qin De-Feng	2014/04/06			ecn no	ELX-DG-17378-1																									
TOLERANCES UNLESS OTHERWISE SPECIFIED		chr	-	rel level				Released																									
surface	<table border="1"> <tr> <td>linear</td> <td>0.X</td> <td>±0.25</td> </tr> <tr> <td></td> <td>0.XX</td> <td>±0.13</td> </tr> <tr> <td></td> <td>0.XXX</td> <td>±-</td> </tr> <tr> <td>angular</td> <td>0°</td> <td>±1/2°</td> </tr> </table>	linear	0.X	±0.25		0.XX	±0.13		0.XXX	±-	angular	0°	±1/2°	appr	Pai-Ming Zheng	2014/04/07	product family	MINI-SAS HD	rel level	Released	<table border="1"> <tr> <td>title</td> <td>IX2 INTERNAL ASSEMBLY</td> <td>dwg no</td> <td>10112633</td> <td>rev</td> <td>B</td> </tr> <tr> <td>www.fci.com</td> <td>cat. no.</td> <td>-</td> <td>Product - Customer Drw</td> <td>sheet 3 of 4</td> <td></td> </tr> </table>	title	IX2 INTERNAL ASSEMBLY	dwg no	10112633	rev	B	www.fci.com	cat. no.	-	Product - Customer Drw	sheet 3 of 4	
linear	0.X	±0.25																															
	0.XX	±0.13																															
	0.XXX	±-																															
angular	0°	±1/2°																															
title	IX2 INTERNAL ASSEMBLY	dwg no	10112633	rev	B																												
www.fci.com	cat. no.	-	Product - Customer Drw	sheet 3 of 4																													



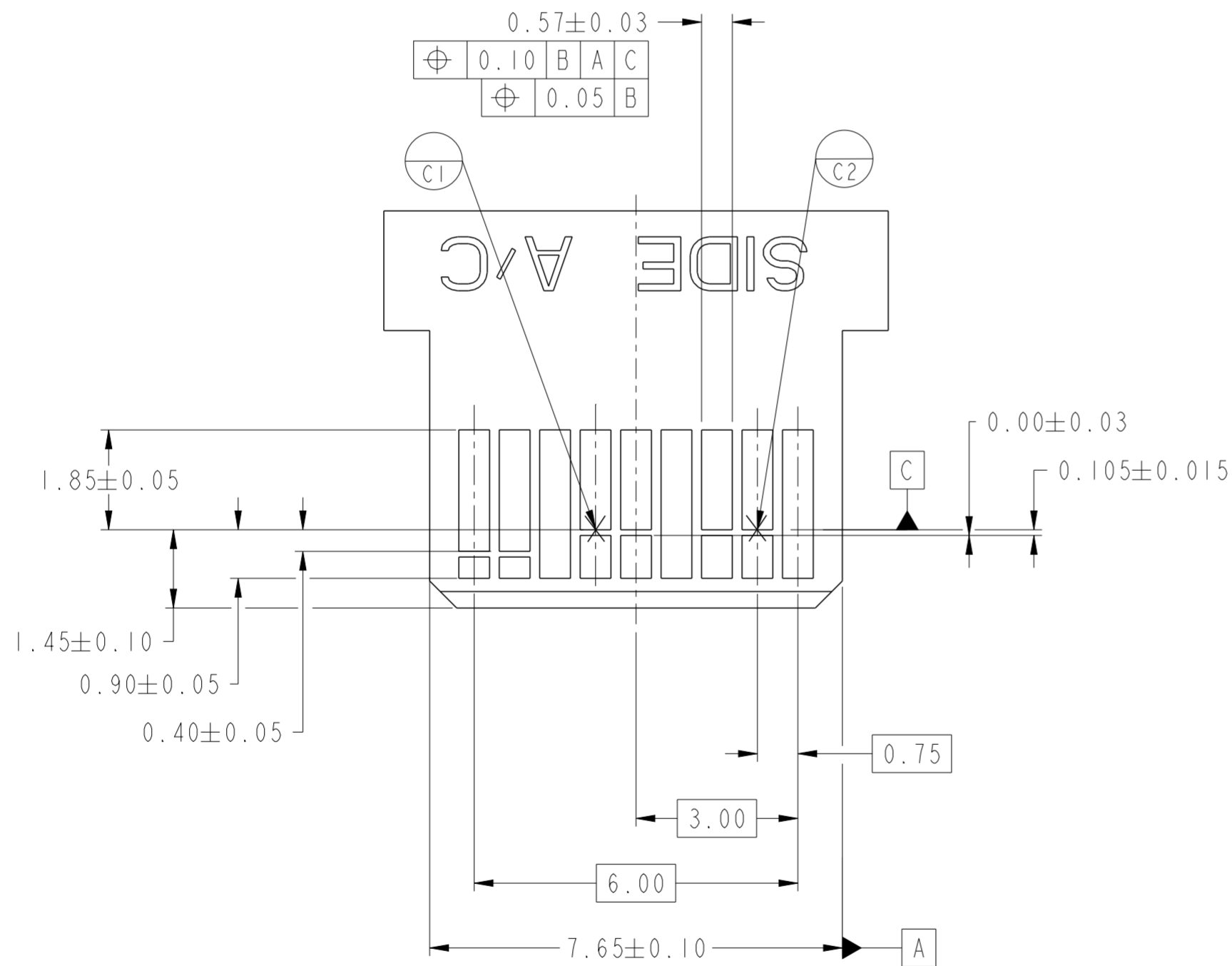
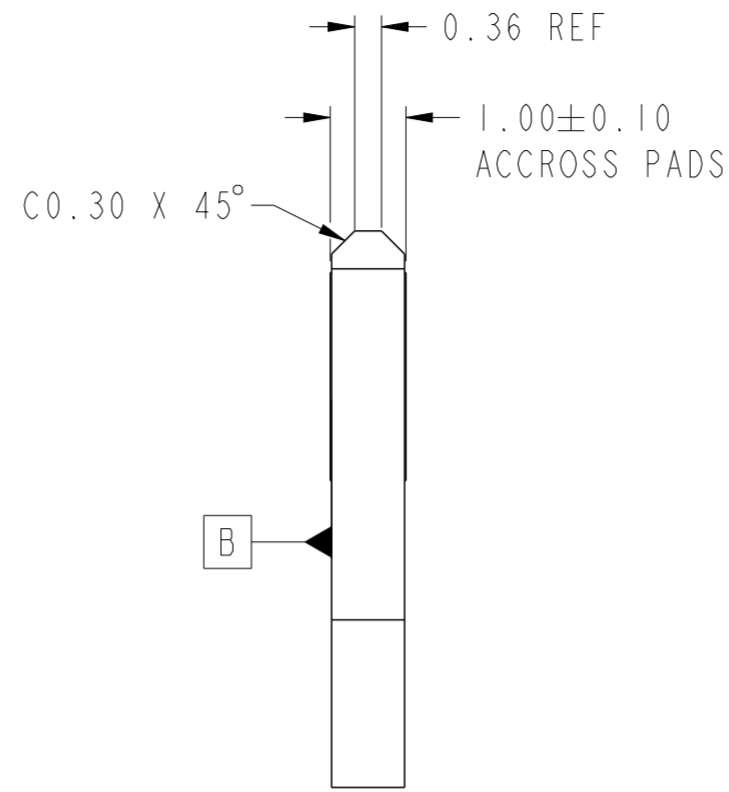
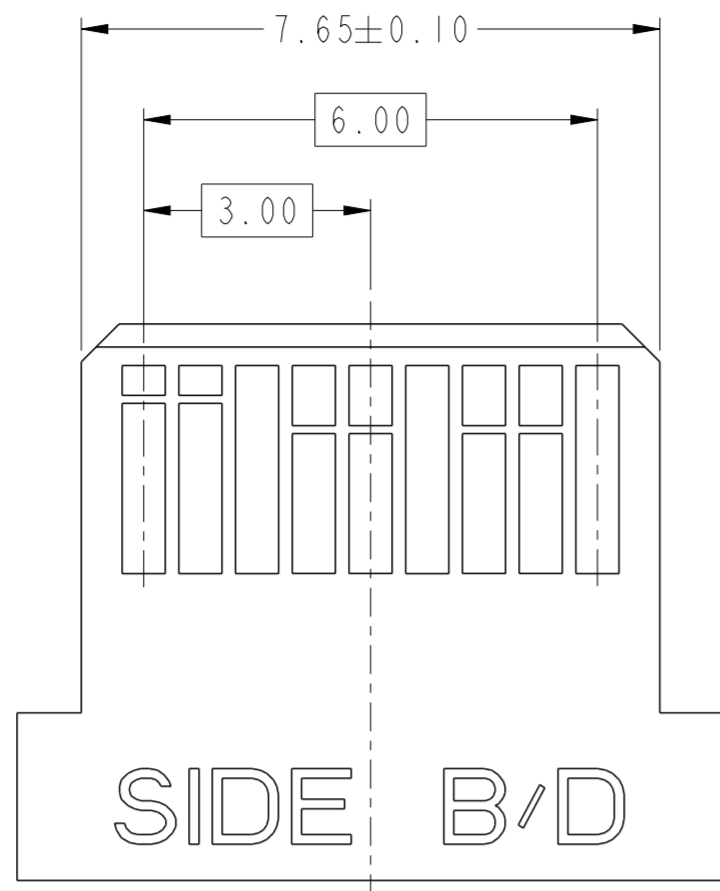

NOTES:

- 0.05 MINIMUM KEEP OUT SOLDER MASK AROUND ALL PADS.
- DATUM C TARGETS ARE DEFINED BY THE RESPECTIVE PAD CENTER LINES AND THE LEADING EDGE OF THE TARGET PADS.

spec ref	-	dr	Mark Gray	2010/08/04	projection	MM	size	A2	scale	2:1
tolerance std	ASME Y14.5	eng	Qin De-Feng	2014/04/06	chr	-	ecn no	ELX-DG-17378-1	rel level	Released
surface	✓	appr	Pei-Ming Zheng	2014/04/07	product family	MINI-SAS HD	cat. no.	10112633	rev	B
ASME Y14.5	linear	0.X	±0.25	0.XX	±0.13	0.XXX	±	angular	0°	±1/2°
		www.fci.com		title		IX2 INTERNAL ASSEMBLY		Product - Customer Drw		sheet 4 of 4

