

ISS.	AMEND	DATE
1	ISSUED	26/10/12

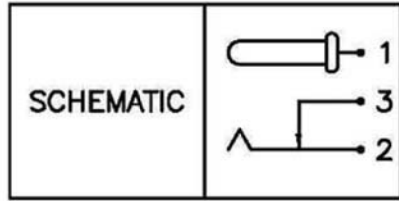

$\phi 2.5 + \phi 2.1$
SEE TABLE
FOR P/No.

PART NUMBER	PIN Ø
FC681477	Ø2.50
FC681478	Ø2.10

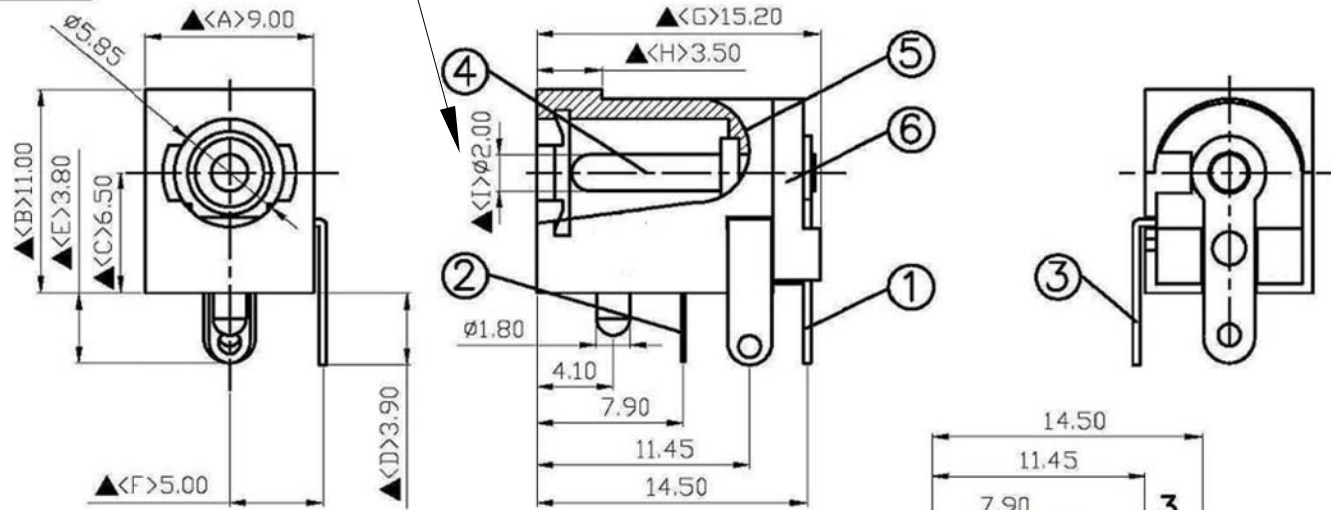

6.	Cover	PBT+30%G	1	Black Color
5.	Housing	PBT+30%G	1	Black Color
4.	Pin(2.0Ø)	Copper	1	Nickel Plated
3.	Break Terminal	0.4T Brass	1	Silver Plated
2.	Sleeve Spring	0.2T Phosphor Bronze	1	Silver Plated
1.	Pin Terminal	0.4T Brass	1	Silver Plated
NO.	Description	Material	Q'TY	Finish

SPECIFICATIONS

Contact Resistance : 30mΩ max
 Current Rating : max 2.0A, 16V DC
 Insulation Resistance : 100MΩ min at DC 500V
 Dielectric Withstanding Voltage : AC 500V for 1 minute

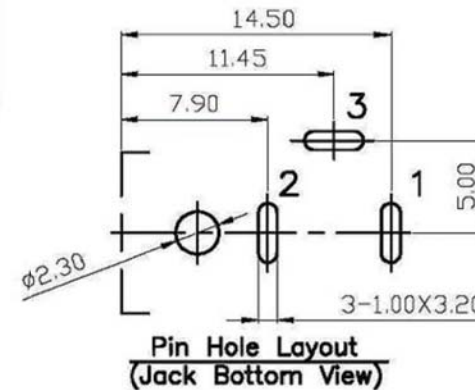

RoHS
COMPLIANT

TOLERANCE
 NO DEC. PLACE ±
 1 DEC. PLACE ±
 2 DEC. PLACE ±
 HOLE Ø ±
 ANGLES ±
 UNLESS
 OTHERWISE STATED

Cliff Electronic Components Ltd.

76 Holmethorpe Avenue, Holmethorpe Industrial Estate,
 Redhill, Surrey, RH1 2PF, England, UK
 Tel: 01737-771375 Fax: 01737-766012 Website: www.cliffuk.co.uk

DIMENSIONS IN MILLIMETERS UNLESS OTHERWISE STATED. WORK TO DIMENSIONS. REMOVE ALL BURRS. IF IN DOUBT ASK.

3rd ANGLE PROJECTION:

DO NOT SCALE

MATERIAL: SEE TABLE

TITLE: LOCKING DC SOCKET Ø2.5mm + Ø2.1mm

FINISH: CLEAN

DRWG. No. **FC681477**

FORM: A4DRWGH

THE CONTENTS OF THIS DOCUMENT MUST NOT BE COPIED OR DISCLOSED TO A 3rd PARTY WITHOUT WRITTEN PERMISSION OF CLIFF UK. © 2012

DRAWN: T.J.O.

APPROVED: D.P.J.