

TOLERANCE UNLESS OTHERWISE SPECIFIED IN MM:
 0 ANGLE ±1°
 0.0 ±0.2
 0.00 ±0.1
 0.000 ±0.05

THIS IS A C.A.D. GENERATED DRAWING
 DO NOT MAKE MANUAL REVISIONS TO MASTER.

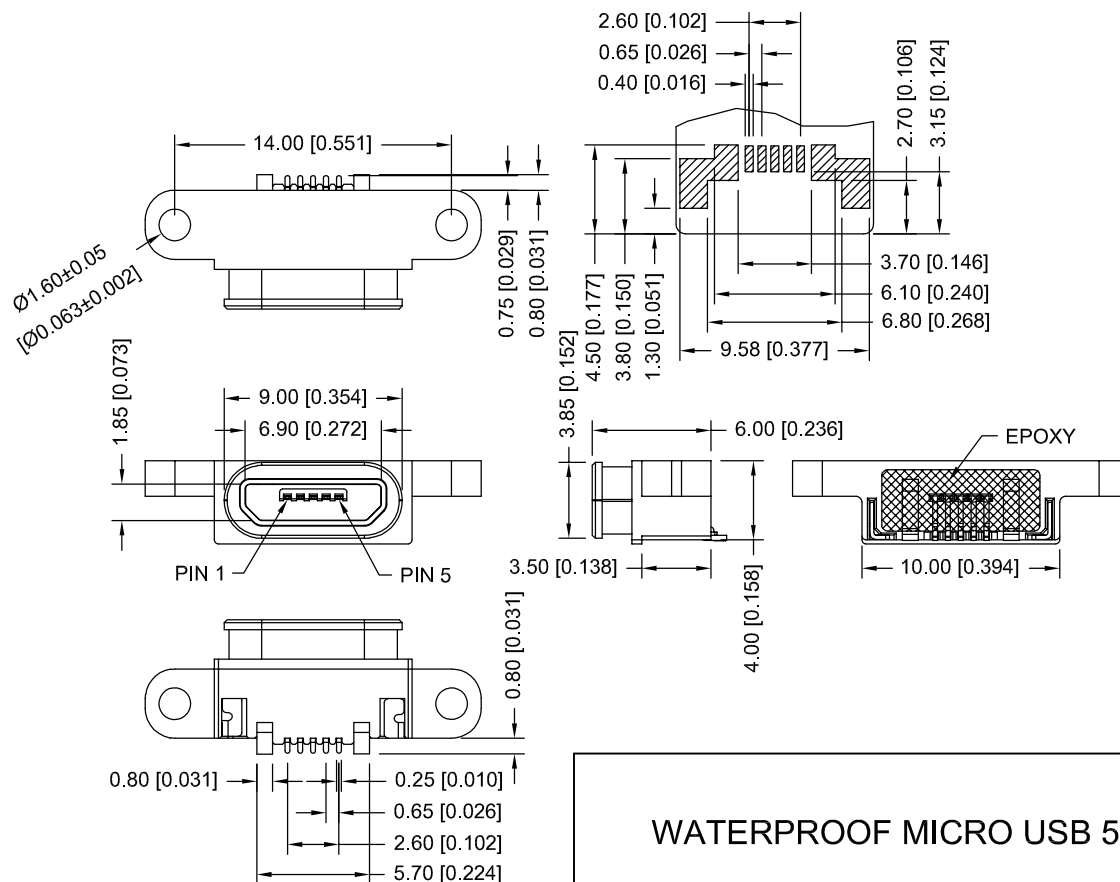

ISSUE NUMBER	
ORIGINAL	①
ADD PACKAGING SPECS SEE PAGE 2 OF 2 R.STA.MONICA	②
SEPT.16/2014	

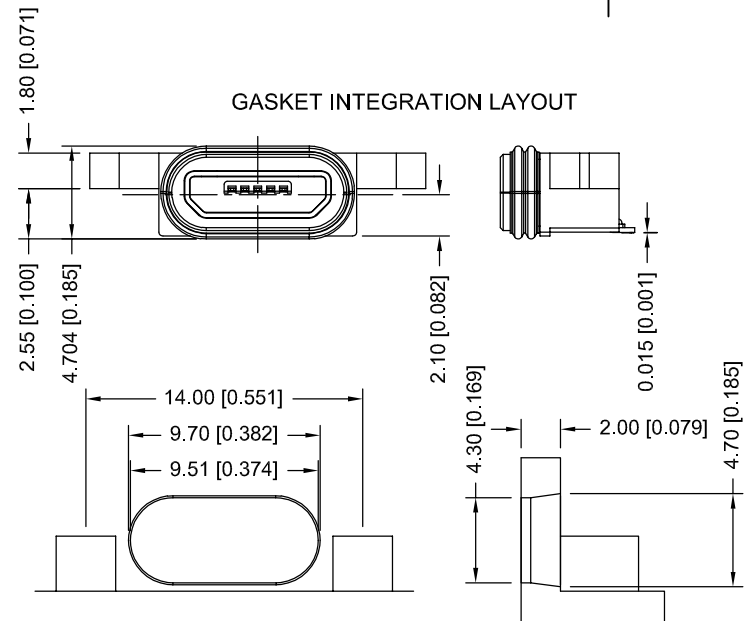
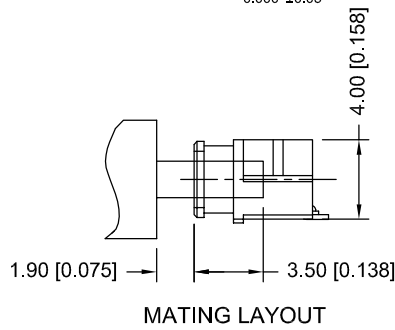
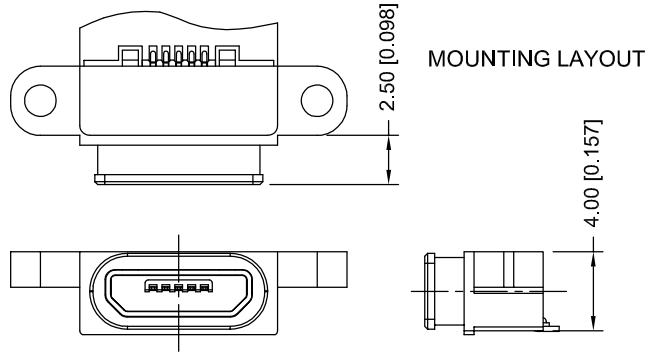

MATERIALS:
 INSULATOR: LCP, UL94 V-0, COLOR: BLACK
 CONTACT: PHOSPHOR BRONZE, WITH 10 µIN OF GOLD PLATING ON CONTACT AREA,
 AND GOLD FLASH ON SOLDER AREA OVER NICKEL UNDERPLATING
 SHELL: STAINLESS STEEL, WITH MATTE TIN PLATING
 O-RING: SILICON
 PAD: BRASS, WITH MATTE TIN PLATING

RoHS COMPLIANT
 THIS SERIES FULLY CONFORMS TO THE EUROPEAN UNION DIRECTIVES 2002/95/EC AND 2002/96/EC FOR RoHS COMPLIANCY.

WATERPROOF MICRO USB 5P(F) SMT TYPE		ACAD REFERENCE NO.: 690-W05-290-483	
		DRAWN: R.STA.MONICA	DATE: JAN.20/2014
EDAC INC TORONTO, ONTARIO CANADA YOUR CONNECTION TO QUALITY & SERVICE		CHECKED:	DATE:
		PART NUMBER 690-W05-290-483	
THESE DRAWINGS AND SPECIFICATIONS ARE THE PROPERTY OF EDAC INC., AND SHALL NOT BE REPRODUCED, OR COPIED OR USED AS THE BASIS FOR THE MANUFACTURE OR SALE OF APPARATUS WITHOUT WRITTEN PERMISSION.		DRAWING NUMBER 690-W05-290-483	SHEET 1 OF 2 ISSUE 2

TOLERANCE UNLESS OTHERWISE SPECIFIED IN MM:
 0 ANGLE ±1°
 0.0 ±0.2
 0.00 ±0.1
 0.000 ±0.05

THIS IS A C.A.D. GENERATED DRAWING
 DO NOT MAKE MANUAL REVISIONS TO MASTER.

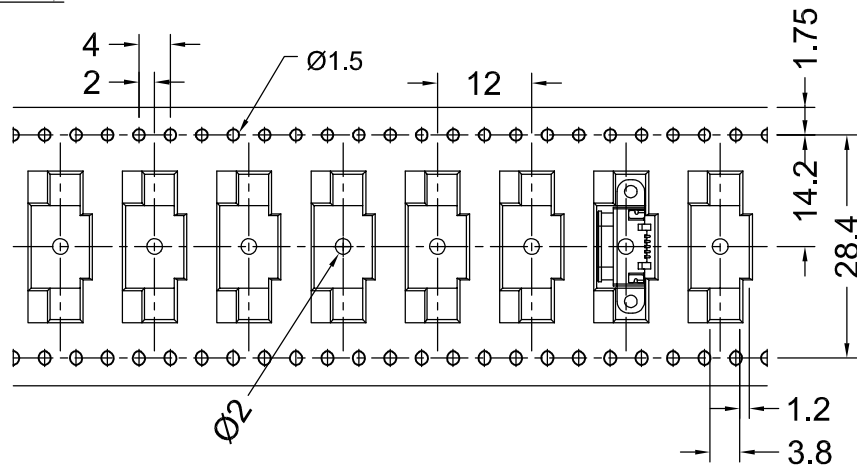
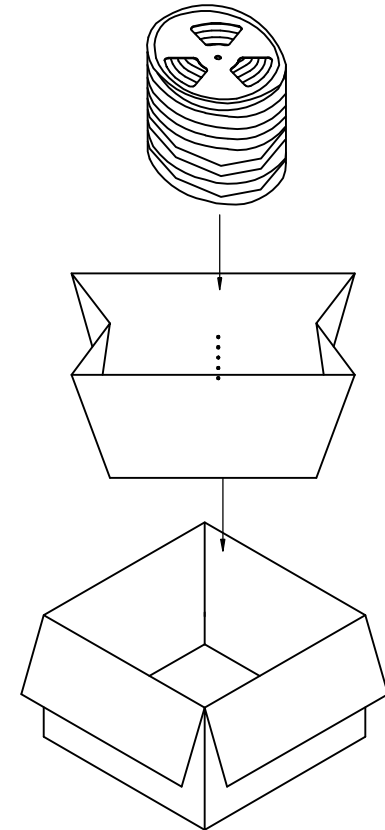
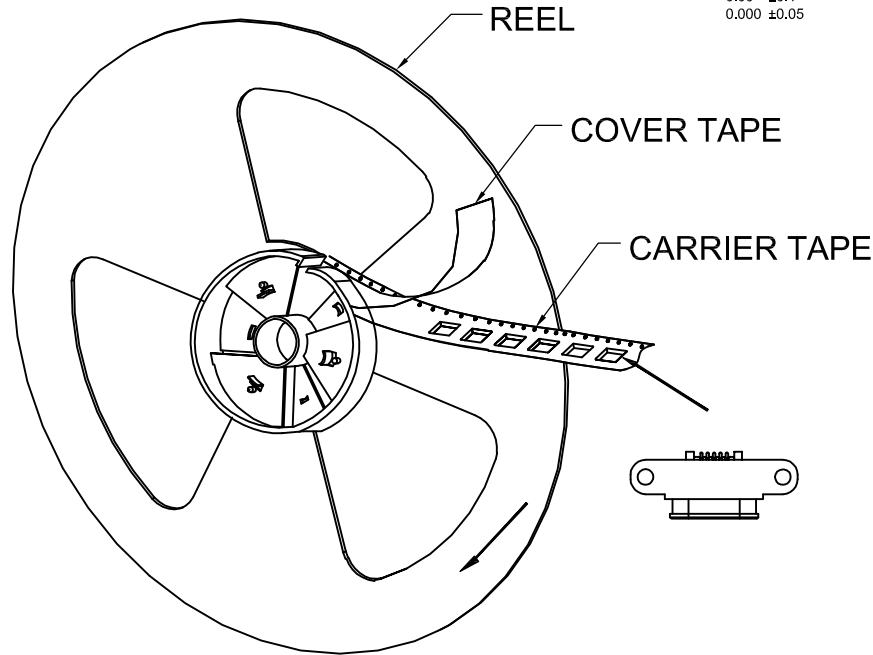
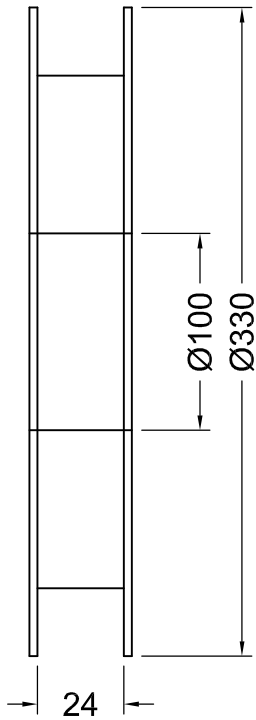

QUANTITY PER REEL: 1100 PCS



THIS SERIES FULLY CONFORMS TO THE EUROPEAN UNION DIRECTIVES 2002/95/EC AND 2002/96/EC FOR RoHS COMPLIANCY.

**WATERPROOF MICRO USB 5P(F) SMT TYPE
 PACKAGING SPECS**



EDAC INC
 TORONTO, ONTARIO
 CANADA

YOUR CONNECTION TO QUALITY & SERVICE

THESE DRAWINGS AND SPECIFICATIONS ARE THE PROPERTY OF EDAC INC., AND SHALL NOT BE REPRODUCED, OR COPIED OR USED AS THE BASIS FOR THE MANUFACTURE OR SALE OF APPARATUS WITHOUT WRITTEN PERMISSION.

ACAD REFERENCE NO.: 690-W05-290-483

DRAWN: R.STA.MONICA DATE: SEPT.16/2014

CHECKED: DATE:

PART NUMBER **690-W05-290-483** SHEET 2 OF 2

DRAWING NUMBER **690-W05-290-483** ISSUE 2