

DESCRIPTION: MALE - HIGH DENSITY - MACHINED CONTACTS - VERTICAL

**MATERIALS AND FINISH:**

SHELL: STEEL MATERIAL, NICKEL FINISH  
 INSULATOR: PA6T = 260°C, UL 94V-0 RATED, BLACK  
 CONTACT MATERIAL: BRASS  
 CONTACT FINISH: FULL GOLD FLASH  
 SEAL MATERIAL: F08 FLEXIBLE ADHESIVE

**ELECTRICAL:**

CONTACT CURRENT RATING: 5 AMPS  
 CONTACT RESISTANCE: 30 Milliohms Max.  
 DIELECTRIC WITHSTANDING VOLTAGE: 1,000VAC Min.  
 INSULATION RESISTANCE: 5,000 Megohms Min.  
 TEMPERATURE RATING: -55° ~ +105° C

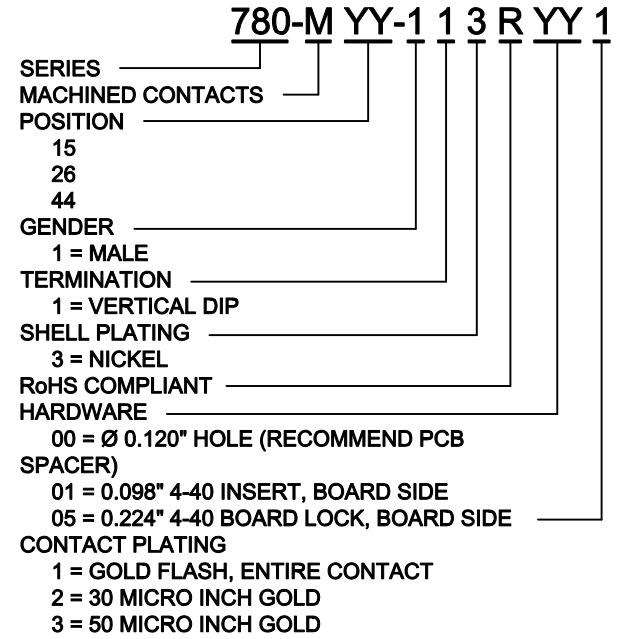
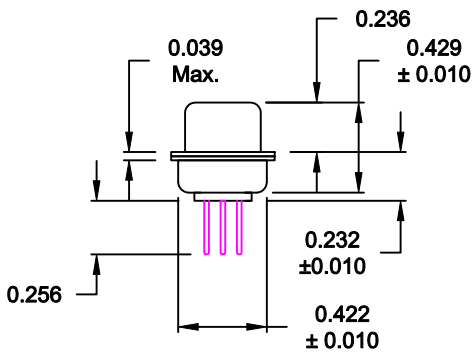
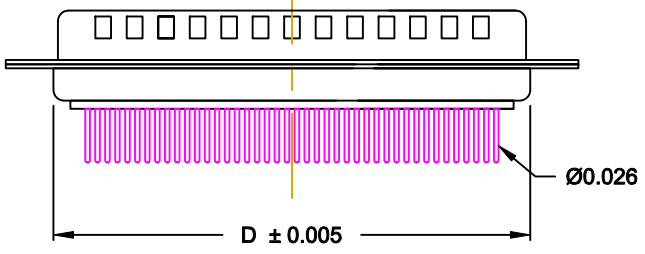
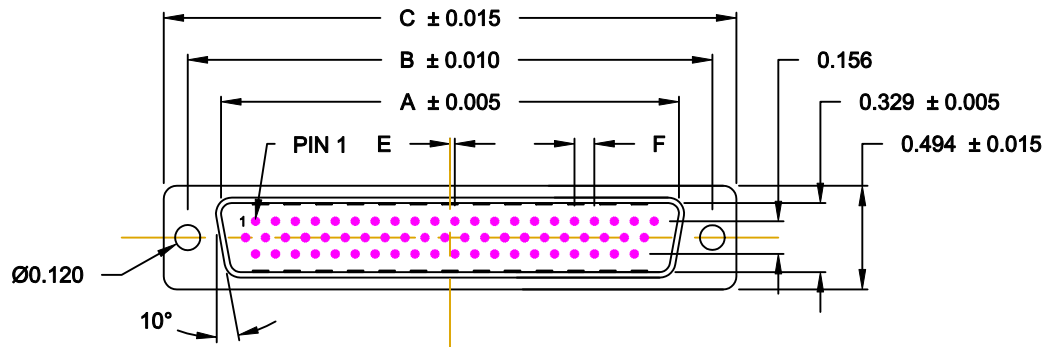

DIMENSIONS (IN.)						
No. OF PINS	A	B	C	D	E	F
15	0.666	0.984	1.213	0.759	0.010	0.090
25	0.994	1.312	1.541	1.083	0.020	0.090
44	1.534	1.852	2.088	1.625	0.020	0.090

**MEETS IP67 STANDARDS**  
 (SEE PAGE 3 FOR SEALING DETAILS)

**DO NOT SCALE FROM DRAWING**

	THESE DRAWINGS AND SPECIFICATIONS ARE THE PROPERTY OF NorComp AND SHALL NOT BE REPRODUCED, COPIED OR USED AS THE BASIS FOR THE MANUFACTURE OF SALE OF APPARATUS WITHOUT WRITTEN PERMISSION.		DRAWN: P. JENKINS	DATE: 06-08-09
			CHECKED:	DATE:
		SCALE: 1 : 1	SHEET 1 OF 4	REV 8
		DWG NO. 780-MYY-113RYY1		

**RoHS COMPLIANT**

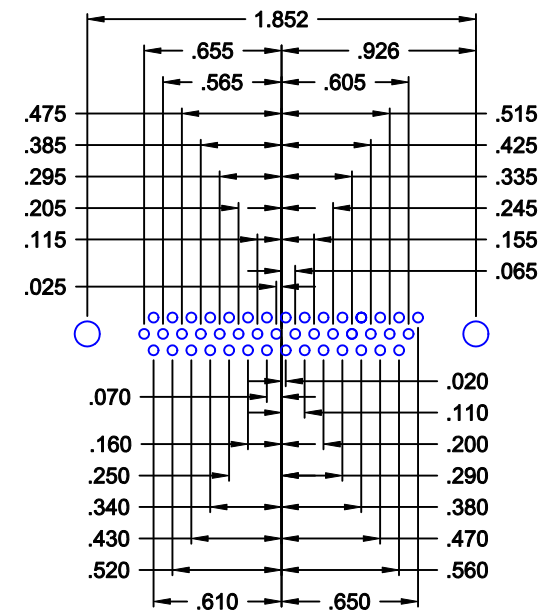
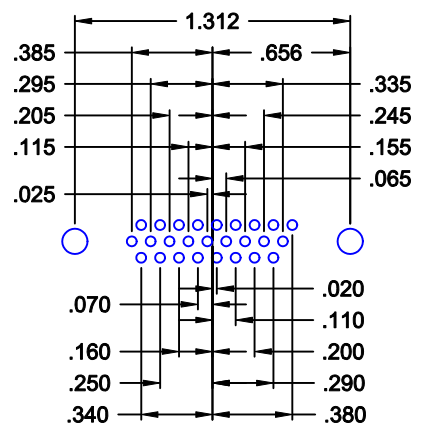
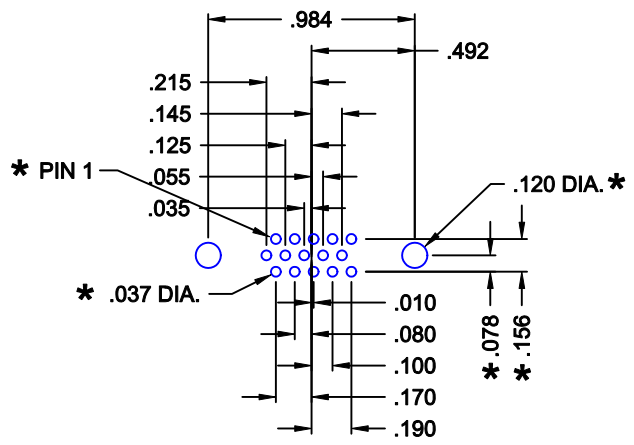

\* TYP. ON ALL SIZES

DO NOT SCALE FROM DRAWING

	THESE DRAWINGS AND SPECIFICATIONS ARE THE PROPERTY OF NorComp AND SHALL NOT BE REPRODUCED, COPIED OR USED AS THE BASIS FOR THE MANUFACTURE OF SALE OF APPARATUS WITHOUT WRITTEN PERMISSION.		DRAWN: <b>P. JENKINS</b>	DATE: <b>06-08-09</b>
			CHECKED:	DATE:
<b>NorComp</b>		SCALE: 1 : 1	SHEET 2 OF 4	REV 8
		DWG NO. <b>780-MYY-113RYY1</b>		

**ALL CLINCH-NUTS ARE 4-40 INTERNAL THREADS**

01X ..... 0.098" (BOARD SIDE) - CN1

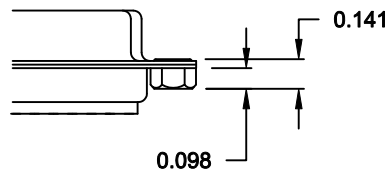

05X ..... 0.237" BOARD SIDE - CN10

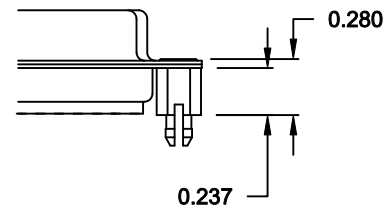

**DO NOT SCALE FROM DRAWING**



THESE DRAWINGS AND SPECIFICATIONS ARE THE PROPERTY OF NorComp AND SHALL NOT BE REPRODUCED, COPIED OR USED AS THE BASIS FOR THE MANUFACTURE OF SALE OF APPARATUS WITHOUT WRITTEN PERMISSION.

DRAWN:  
**M. SIGMON**

DATE:  
**12-10-10**

CHECKED:

DATE:

SCALE:

SHEET **3** OF **4**

REV **8**

**NorComp**

DWG NO. **780-MYY-113RYY1**

**RoHS COMPLIANT**

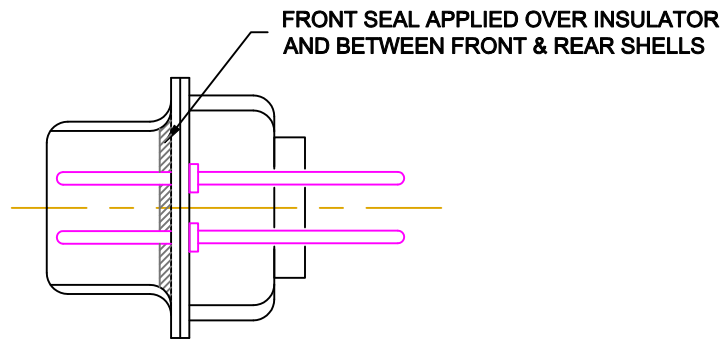
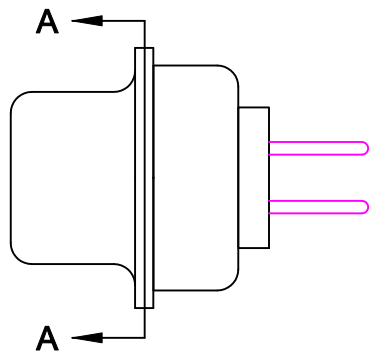

DETAIL A-A

DO NOT SCALE FROM DRAWING

	THESE DRAWINGS AND SPECIFICATIONS ARE THE PROPERTY OF NorComp AND SHALL NOT BE REPRODUCED, COPIED OR USED AS THE BASIS FOR THE MANUFACTURE OF SALE OF APPARATUS WITHOUT WRITTEN PERMISSION.		DRAWN: <b>C. SMITH</b>	DATE: <b>06-10-09</b>	
			CHECKED:	DATE:	
<h1>NorComp</h1>			SCALE: <b>2.5 : 1</b>	SHEET <b>4</b> OF <b>4</b>	REV <b>8</b>
			DWG NO. <b>780-MYY-113RYY1</b>		