

SCALA 0.400

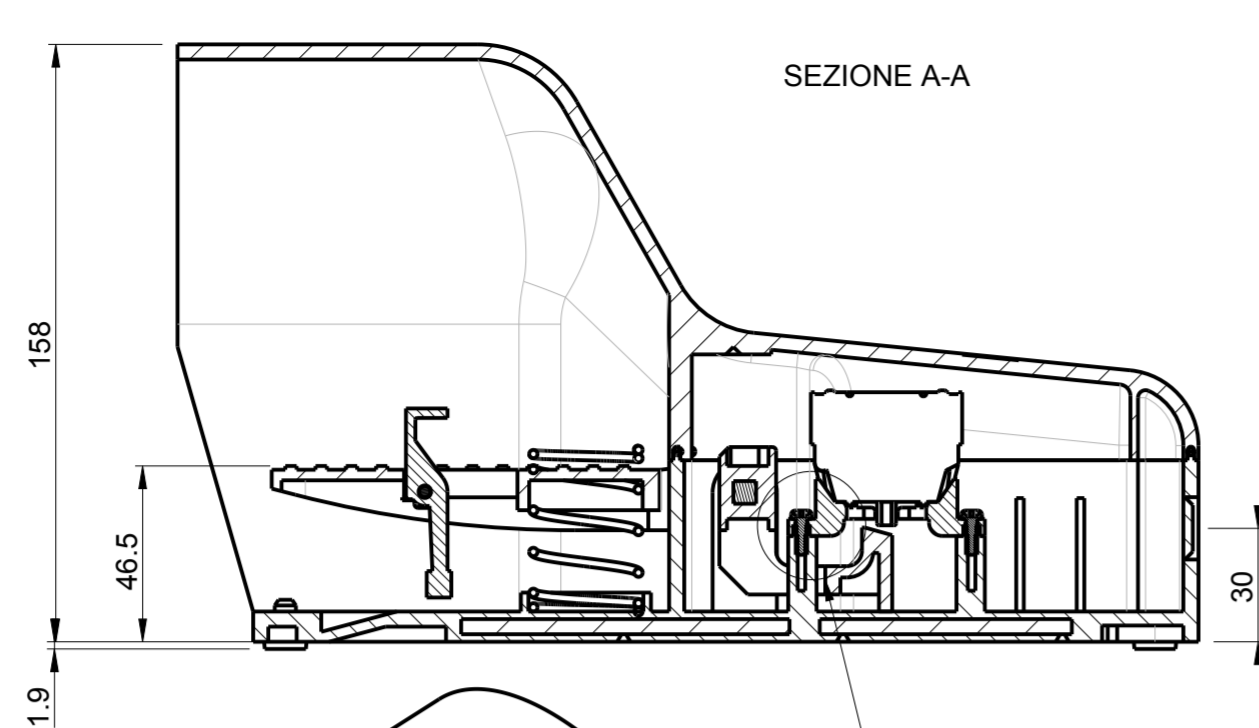

SEZIONE A-A

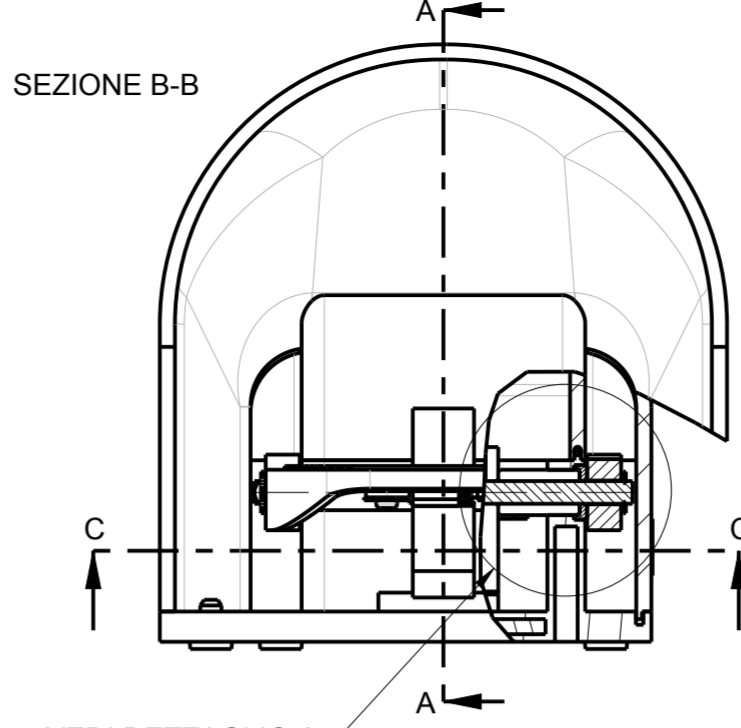

SEZIONE B-B

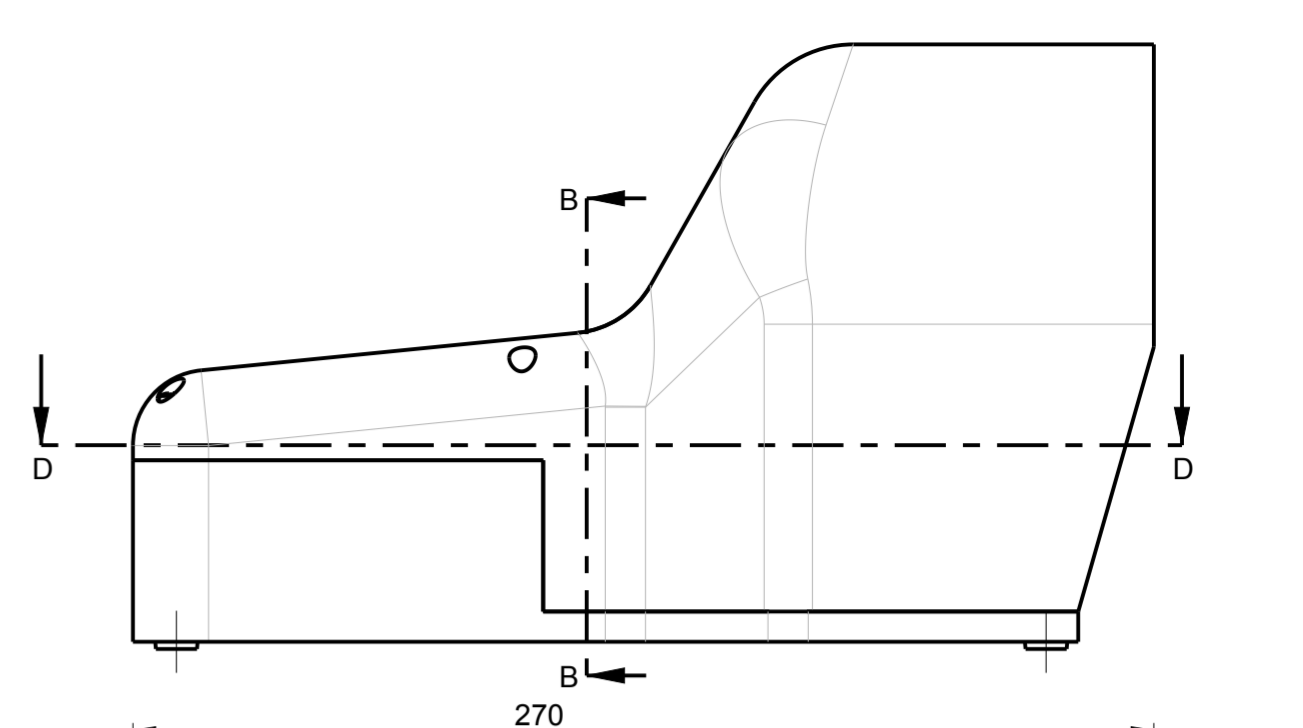

SEZIONE D-D

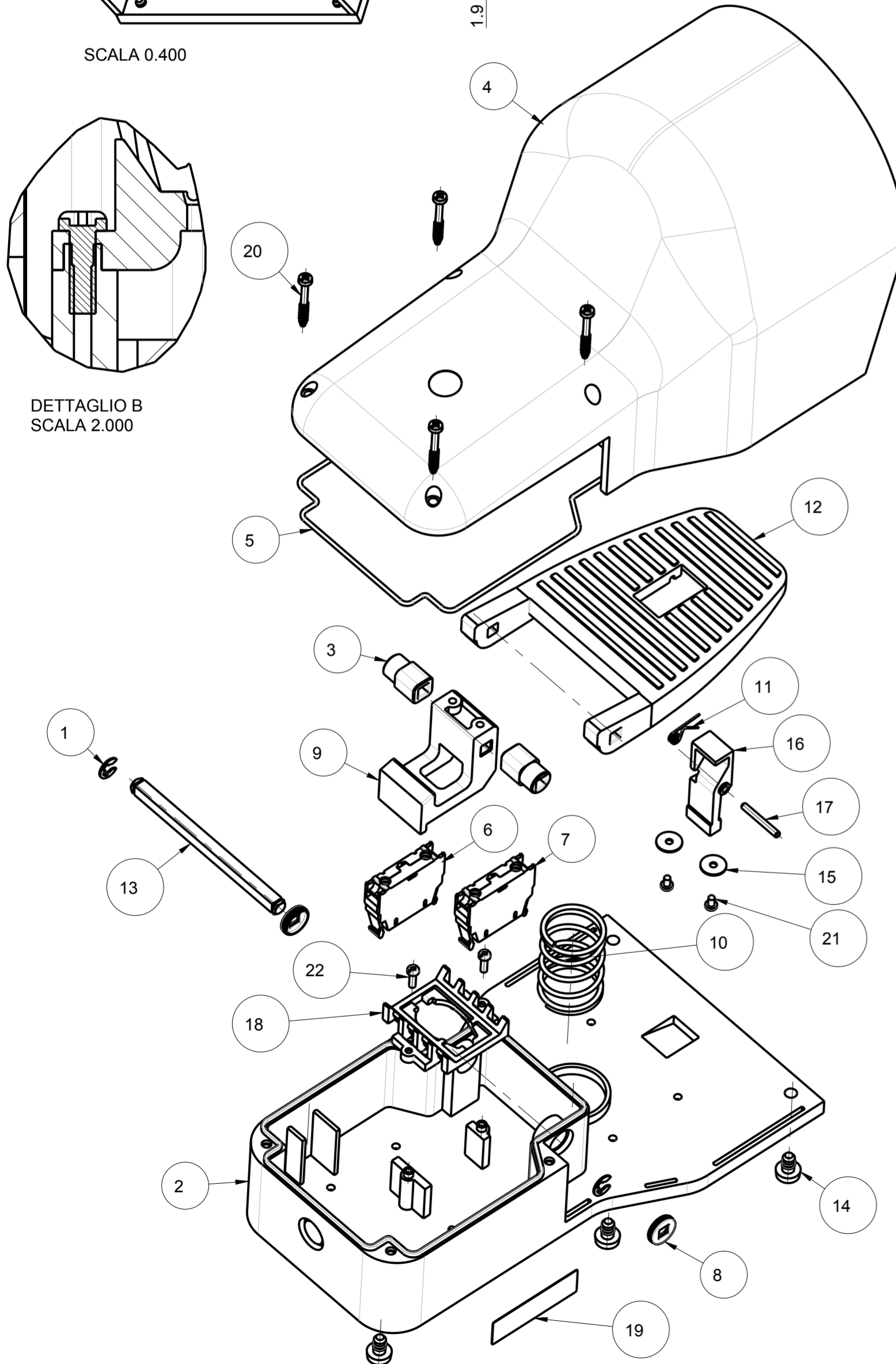

DETTAGLIO B  
SCALA 2.000

APPLICARE GRASSO SYNGREASE  
NELLA SEDE X LA GUARNIZIONE

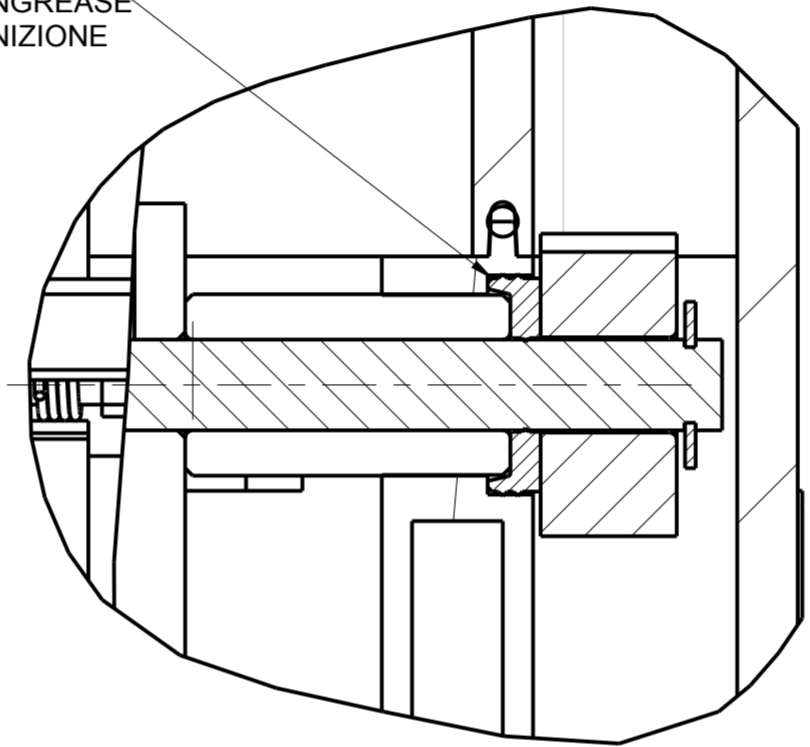

DETTAGLIO A  
SCALA 2.000

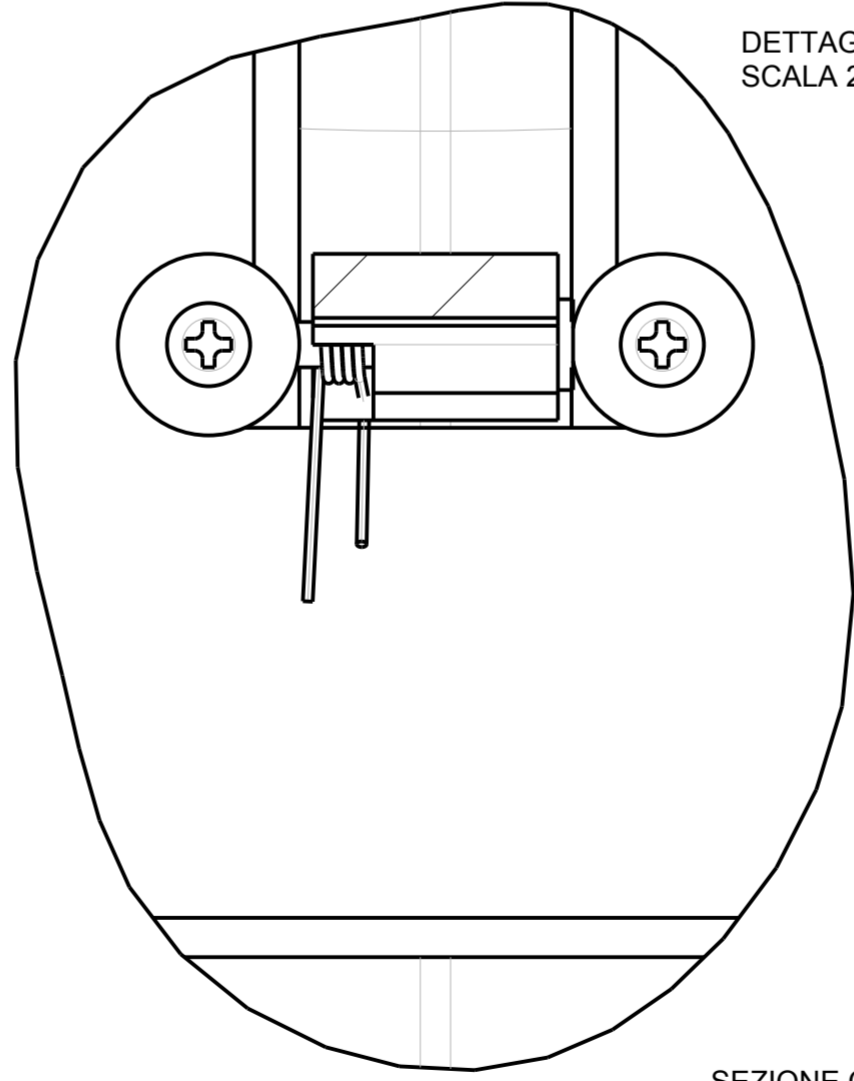

SEZIONE C-C  
SCALA 2.000

PARTICOLARE MONTAGGIO SICURA

22	VITE TC 3x9.5 SCREWPLAST NERA	CROSS RECESSED PAN HEAD SCREW 3X9.5	11606025	2
21	VITE TC 2E9X6E5 AUTOFIL UNI6954	THREAD FORMING SELF TAPPING SCREW 2.9x6.5	11607011	2
20	VITE AUTOFIL 4x30 FIL PARZ INOX	THREAD FORMING SELF TAPPING SCREW	11606022	4
19	TARGHETTA PER PEDALIERA IP7007I	LABEL FOR FOOT SWITCH IP7007I	13203013	1
18	SUPPORTO 4 FRUTTI 16A	4 SPRING CONTACT BLOCK SUPPORT	11705102	1
17	SPINA CILINDRICA D3X24	CILINDRIC PIN	19000012	1
16	SICURA PEDALE	FOOT SECURITY	19000005	1
15	RONDELLA D 3,2x12 UNI6593	WASHER D3.2x12uni6593	11616000	2
14	PIEDINO PEDALIERA	RUBBER FEET	19000010	4
13	PERNO	PIN	19000009	1
12	PEDALE	PEDAL	19000004	1
11	MOLLA PER SICURA PEDALE	SPRING FOR FOOT SECURITY	19000008	1
10	MOLLA PER PEDALIERA	FOOT SWITCH SPRING	19000007	1
9	LEVA UNCINO	HOOK LEVER	19000011	1
8	GUARNIZIONE PEDALIERA	FOOT SWITCH GASKET	19000013	2
7	ELEMENTO DI CONTATTO 1NO 16A	CONTACT BLOCK 1NO 16A	PL004002	1
6	ELEMENTO DI CONTATTO 1NC 16A	CONTACT BLOCK 1NC 16A	PL004001	1
5	CORDA GOMMA D.2 X480	RUBBER ROPE D.2 X480	11901035	1
4	COPERCHIO PEDALIERA	FOOT SWITCH COVER	19000003	1
3	BUSSOLA PEDALIERA COM ELETTRICO	ELECTRIC FOOT SWITCH BUSH	19000018	2
2	BASE PEDALIERA COMANDO ELETTR	ELECTRIC FOOT SWITCH BASE	19000001	1
1	ANELLO BENZING D5	BENZING RING D5	12005003	2

POS	DESCRIZIONE	DESCRIPTION	CODICE / CODE	Q.ty
EDIZIONE / EDITION	DATA / DATE	MOD. / MODIFIED	FIRMA / SIGNATURE	
01	21-02-05	MAGNI R.		
02	26-11-12	MAGNI R.		
03	08-01-14	MAGNI		

GIOVENZANA INTERNATIONAL B.V. Strawinskylaan 1105 1077 XX Amsterdam - NL		FINITURA / FINISH --- MATERIALE / MATERIAL ---
DENOMINAZIONE / DESCRIPTION <b>PEDALIERA_1NA-1NC_LENTO_SECURITY</b> <b>FOOT SWITCH 1NO+1NC SLOW SECURITY</b>		SCALA/SCALE DATA/DATE 0.500 27-01-03 DIS. / DESIGNER <i>Roberto MAGNI R.</i> APPROV. / APPROVED <i>Roberto MAGNI R.</i>
DIM. INGOMBRO L x H x P 270.0 x 158.0 x 150.0	PESO / WEIGHT (g) 0.000	STAMPO / MOULD N° --- FIGURE N°/CAVITY N° --- AVANZAMENTO/STATUS Esecutivo
Tolleranza >0,5 ..6 ±0,05	Dimensioni Nominali / Nominal Dimensions >6 ..30 ±0,1 >30 ..120 ±0,2 >120 ..315 ±0,5 >315 ..1000 ±0,8 >1000 ..2000 ±1,2 >2000 ..4000 ±2,0 >4000 ±3,0	DISEGNO / DRAWING N° <b>IP7007I</b> REVISION <b>03</b>