

DRAWING FOR REFERENCE: This is subject to change without notice
12/05/2013

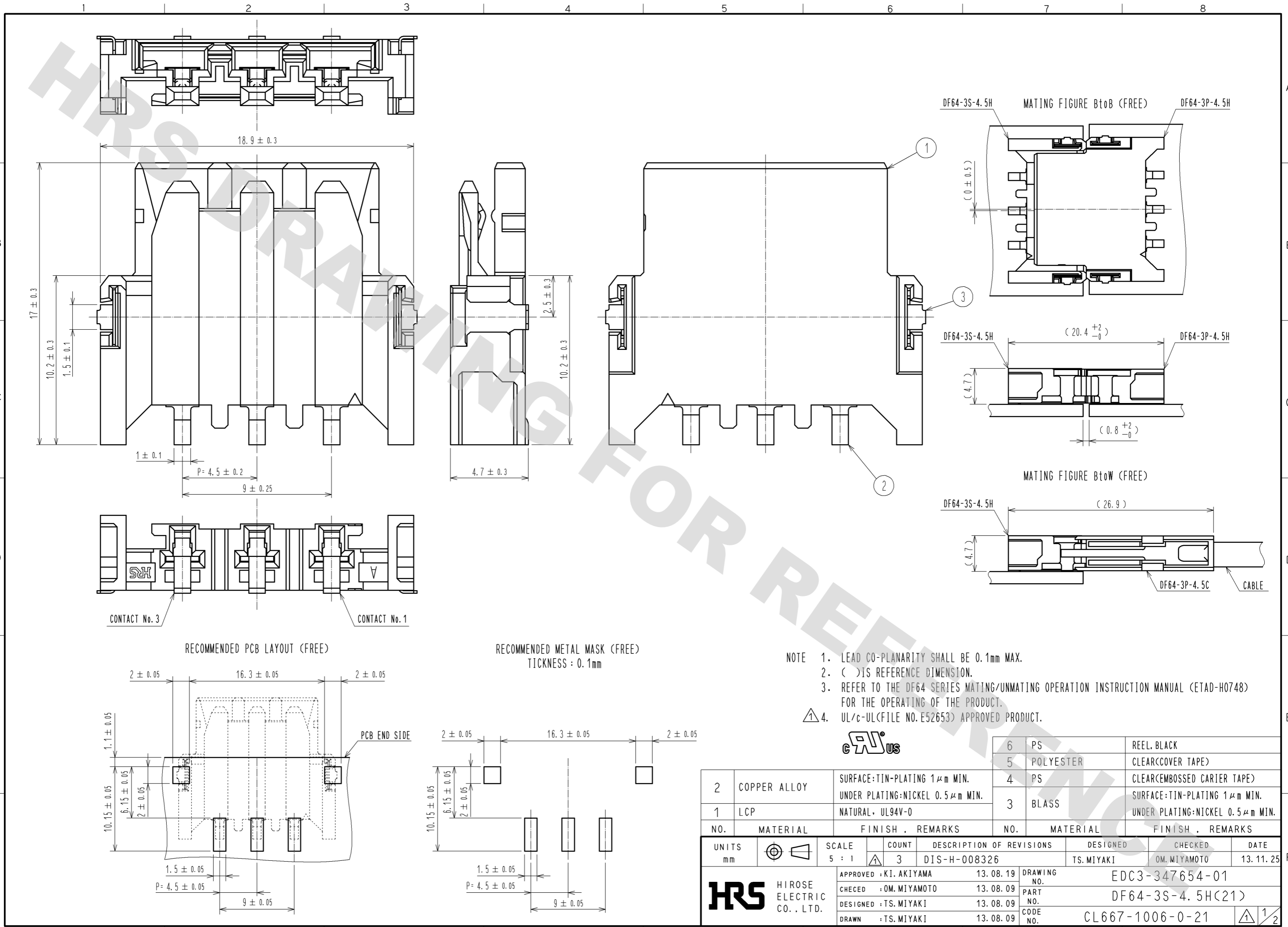

- NOTE 1. LEAD CO-PLANARITY SHALL BE 0.1mm MAX.
 2. () IS REFERENCE DIMENSION.
 3. REFER TO THE DF64 SERIES MATING/UNMATING OPERATION INSTRUCTION MANUAL (ETAD-H0748) FOR THE OPERATING OF THE PRODUCT.
 4. UL/c-UL(FILE NO. E52653) APPROVED PRODUCT.



2	COPPER ALLOY	SURFACE:TIN-PLATING 1μm MIN. UNDER PLATING:NICKEL 0.5μm MIN.	6	PS	REEL, BLACK
1	LCP	NATURAL, UL94V-0	5	POLYESTER	CLEAR(COVER TAPE)
			4	PS	CLEAR(EMBOSSED CARRIER TAPE)
			3	GLASS	SURFACE:TIN-PLATING 1μm MIN. UNDER PLATING:NICKEL 0.5μm MIN.
NO.	MATERIAL	FINISH, REMARKS	NO.	MATERIAL	FINISH, REMARKS
UNITS mm		SCALE 5 : 1	COUNT 3	DESCRIPTION OF REVISIONS	
				DESIGNED TS. MIYAKI	CHECKED OM. MIYAMOTO
				DATE 13.11.25	
HRS HIROSE ELECTRIC CO., LTD.		APPROVED : KI. AKIYAMA	13.08.19	DRAWING NO. EDC3-347654-01	
		CHECKED : OM. MIYAMOTO	13.08.09	PART NO. DF64-3S-4.5H(21)	
		DESIGNED : TS. MIYAKI	13.08.09	CODE NO. CL667-1006-0-21	
		DRAWN : TS. MIYAKI	13.08.09		

DRAWING FOR PACKING (2:1)

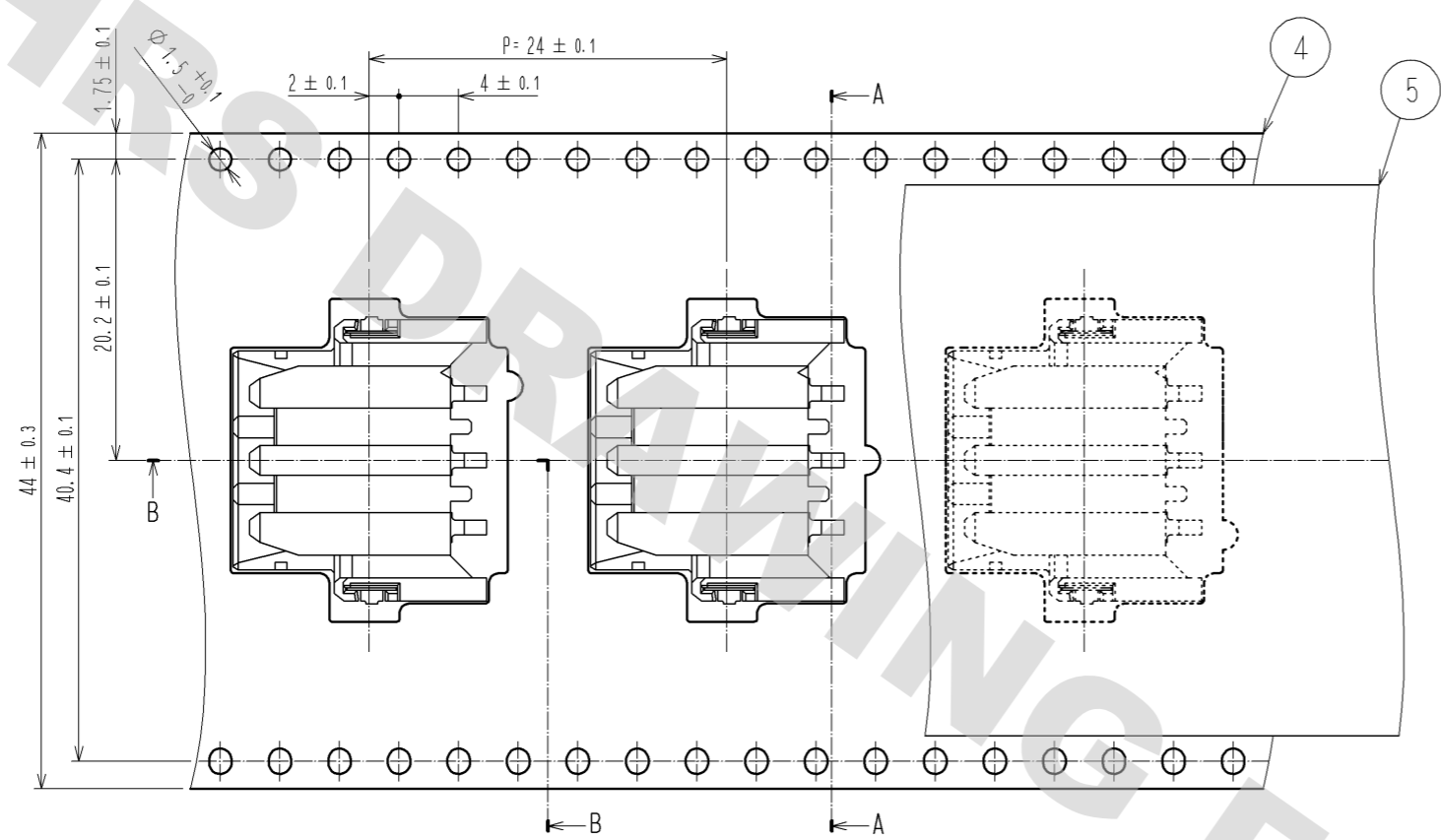

A-A(2:1)

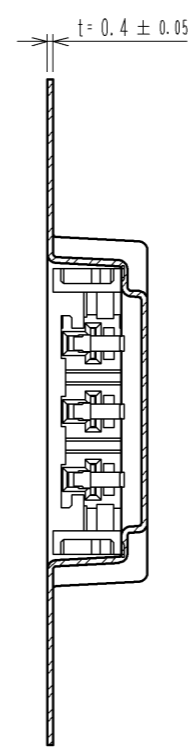

STYLE AND DIMENSION OF REEL(FREE)

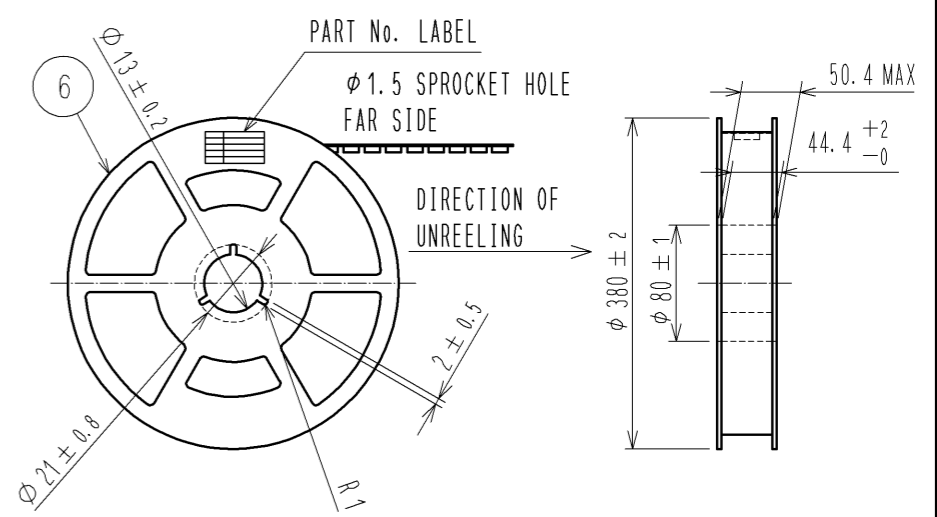

DETAIL OF PART No. LABEL

生産月日	年 月 日
図 番	CL667-1006-0-21
品 名	DF64-3S-4.5H(21)
納入数量	500 K0
納入者	ヒロセ電機(株)

B-B(2:1)

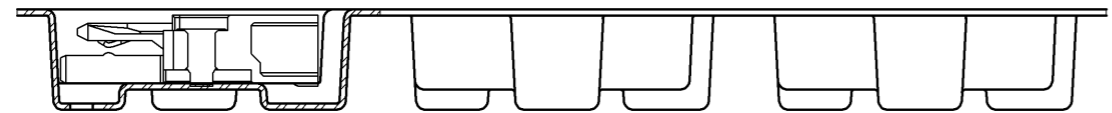

DIRECTION OF REELING →

①⑥ TAPING(FREE)

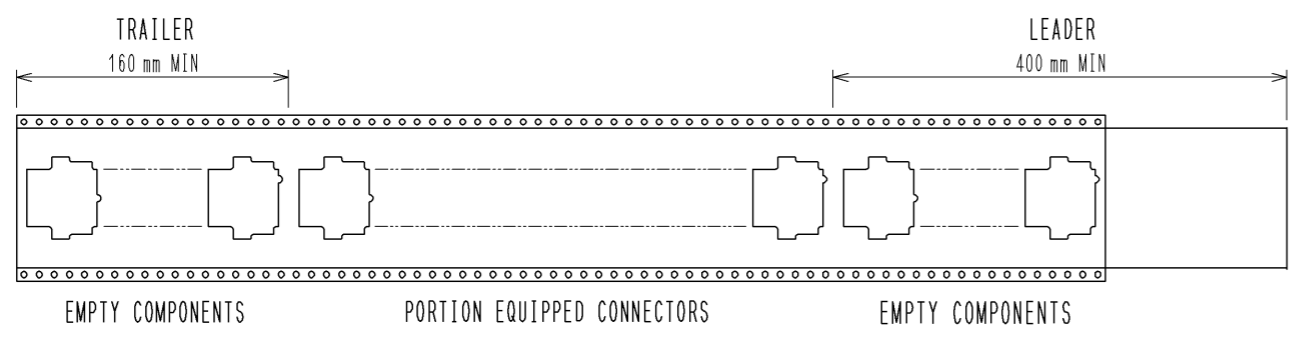

REFLOW TEMPERATURE PROFILE USING LEAD-FREE SOLDER PASTE (REFERENCE)

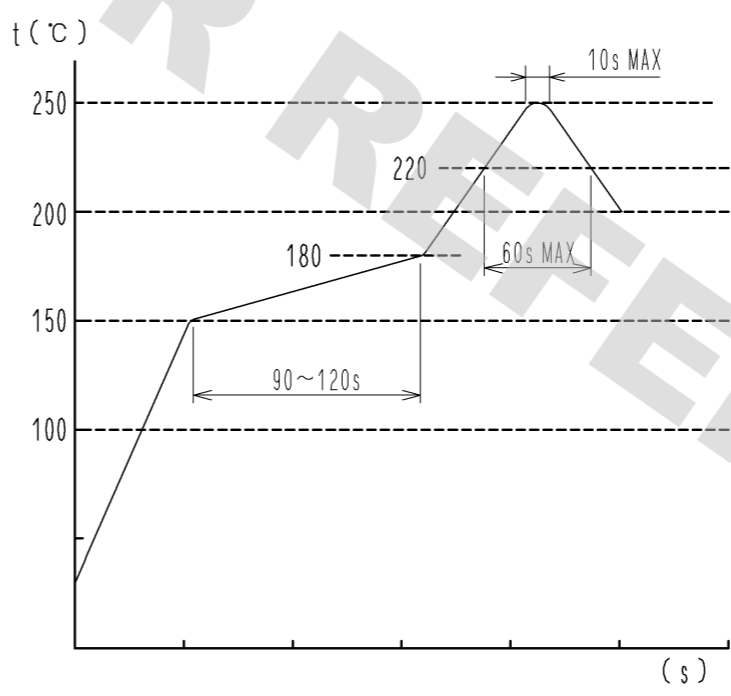

NUMBER OF REFLOW CYCLES 2 CYCLES MAX
 THE TEMPERATURE IS MEASURED IN THE TERMINAL LEAD PART.
 ADDITIONAL FACTORS, SUCH AS SOLDER PASTE TYPE,
 PCB SIZE AND OTHER MOUNTED COMPONENTS COULD AFFECT
 THE PROFILE.
 THEREFOR, A THOROUGH EVALUATION OF MOUNTING CONDITION IS
 REQUIRED PRIOR TO PRODUCTION.
 TEMPERATURE IS MEASURED AT CONTACT LEAD.

- ① NOTE 5. 1REEL:500 CONNECTORS.
- ⑥ REEL TO JIS C 0806.(PACKAGING OF COMPONENTS FOR AUTOMATION HANDLING)
- 7. () IS REFERENCE DIMENSION.

HRS	DRAWING NO.	EDC3-347654-01
	PART NO.	DF64-3S-4.5H(21)
	CODE NO.	CL667-1006-0-21
		①/2

DRAWING FOR REFERENCE: This is subject to change without notice 12/05/2013