

H
G
F
E
D
C
B
A

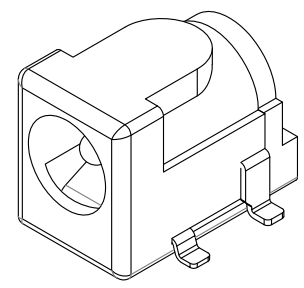
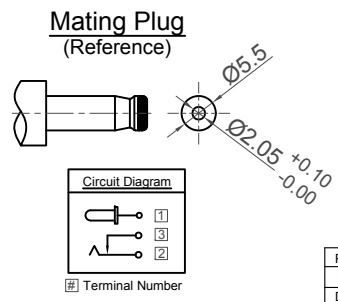
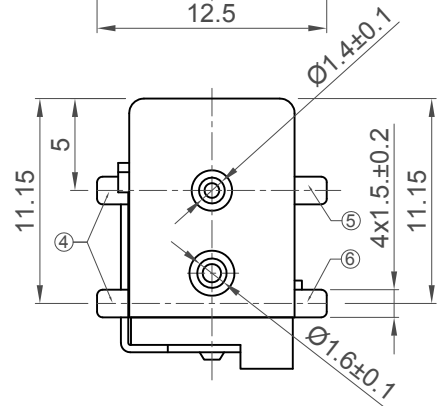
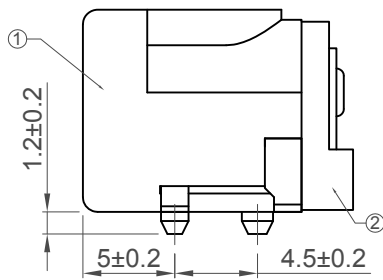
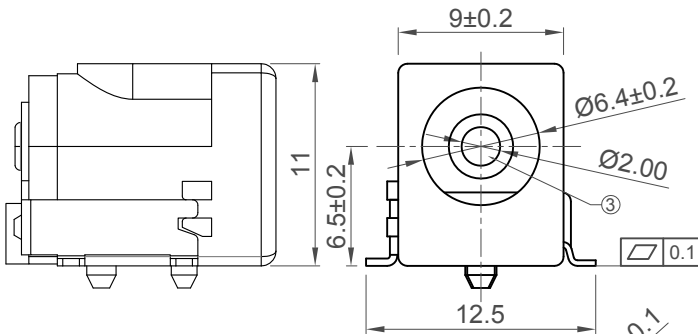
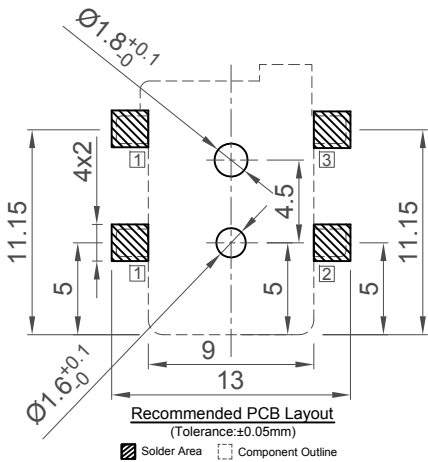
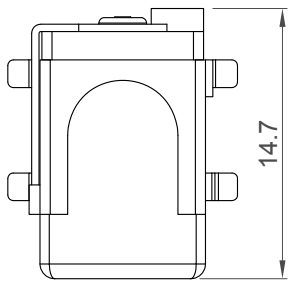
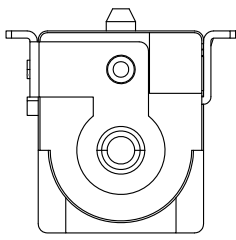

Specifications 规格

Electrical 电气规格

- Voltage rating 电压额定值: 20 V DC
- Current Rating 电流额定值: 5 Amp
- Insulation Resistance 绝缘电阻值: 100 MΩ min.
- Dielectric Withstanding 耐电压: 500 V AC
- Contact Resistance 接触电阻值: 30 mΩ max.

Mechanical & Environmental 机械 & 环境

- Operating Temperature 工作温度: -20°C to +70°C
- Durability 耐久性: 5,000 cycles min.

No.	Description	Material	Q'ty
①	Housing	PA9T, UL94 V-0, Black	1
②	Cover	PA9T, UL94 V-0, Black	1
③	Centre Pin	① Copper alloy, Cu-Sn plating	1
④	Centre Pin Terminal	① Brass, Silver plating	1
⑤	Tip Spring	② Phosphor Bronze, Silver plating	1
⑥	Shunt Terminal	③ Brass, Silver plating	1

Ordering Grid

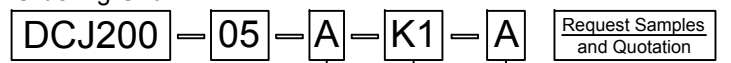

Circuit Diagram

A = 2 Conductors/3 Contacts

Insulator Colour

K1 = Black

Packing

A = Tape and Reel
(250 per reel)

Part Number DCJ200-05		Product Description DC Power Jack, SMT, Horizontal, w/Locating Pegs			This drawing is confidential and copyright of Global Connector Technology, Ltd (GCT). This drawing must not be copied or disclosed without written consent. E & OE
Drawing Date 18th December 2014		Ø2.00mm Pin mates with Ø2.05mm Plug			
By AJO	Detail Drawing Release	Tolerances (Except as Noted) Length ± 0.3	Angle ± 2°	Units: Metric (mm)	Global Connector Technology www.gct.co
Revision A1	Date 06/01/15			Not to Scale Drawn By AJO Sheet No. 1/2	

Part Number	PCS/Reel	Reels/Carton	PCS/Carton
DCJ200-05	250	12	3000

Net Weight/Carton: 6.54kg, Gross Weight/Carton: 11.38kg

Fig 1.

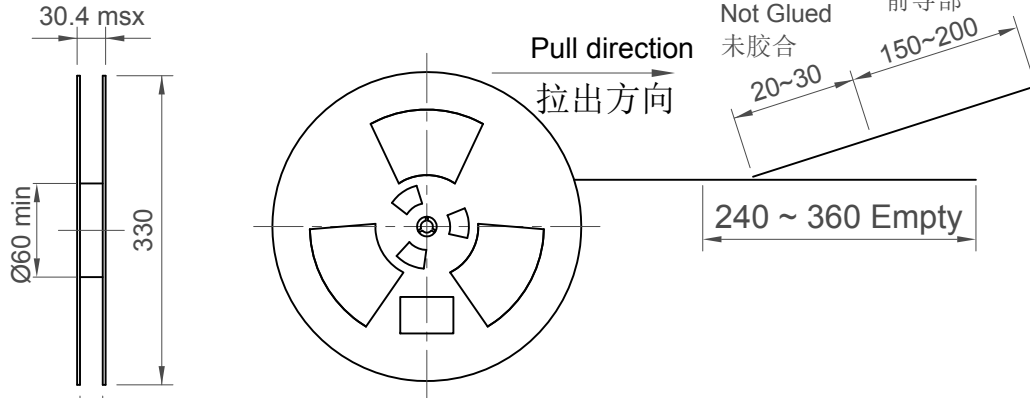
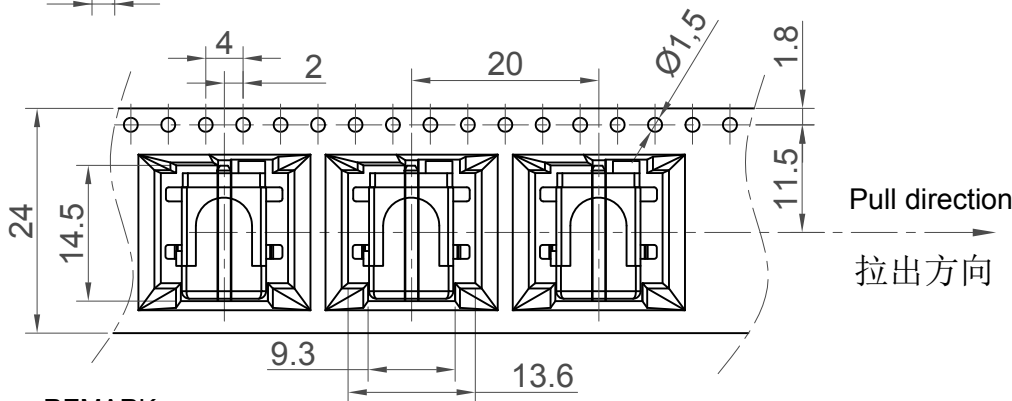

Fig 2.



REMARK:

1. Before packing, keep 160mm empty in the front carriers, don't need to pack, after packed, keep 400mm empty in the back carriers, and let cover tapes keep the same length to the carriers. (Refer to the Figure 1 and 2).
2. When packing, must set the machine according to the Operating Standard (as temperature, air pressure, speed etc), and it can't occur worn, joint etc.
3. When placing the product, can't occur the wrong direction, leakage and shortage etc for the defective status.
4. About the packing number, 250pcs/reel, 2reels/box, 6boxes/carton, the total numbers are 3000pcs per carton, if it isn't full of the carton, put the empty box in until full.
5. When sticking the label: Sitck the label on the reel right side, as Figure 4, don't need to stick for the PE Bag, about the carton's label as Figure 4.

Reel 外觀尺寸圖 Fig 3.

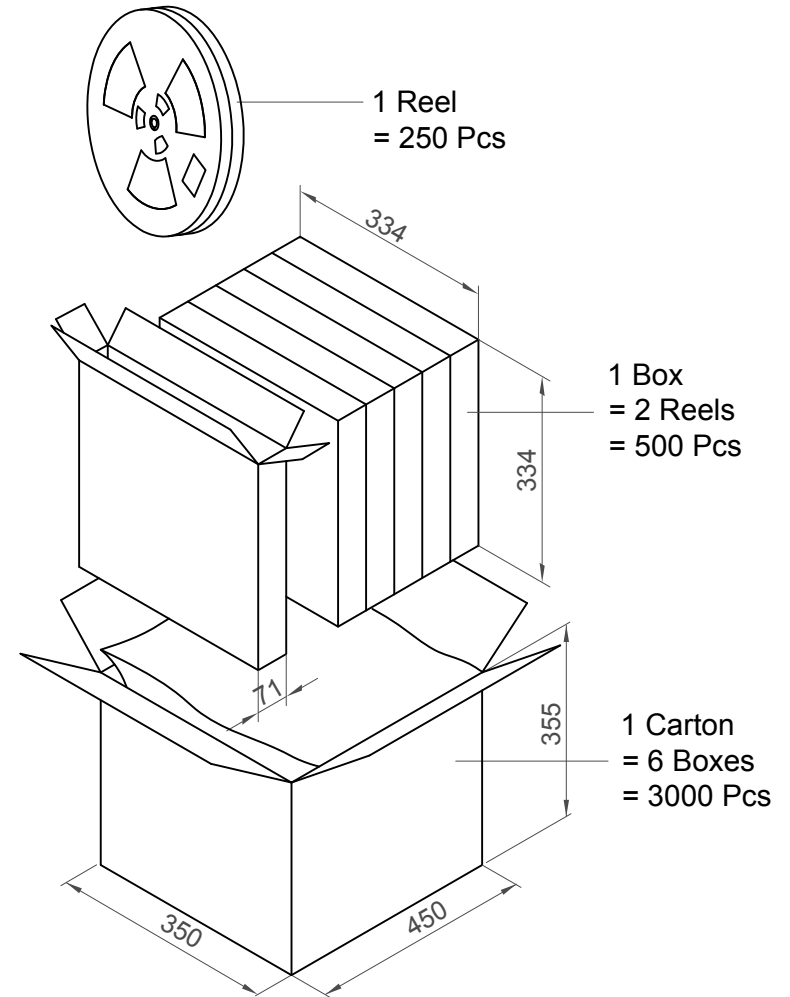

Part Number		Product Description		 This drawing is confidential and copyright of Global Connector Technology, Ltd (GCT). This drawing must not be copied or disclosed without written consent. E & OE		 Global Connector Technology www.gct.co	
DCJ200-05		DC Power Jack, SMT, Horizontal, w/Locating Pegs					
Drawing Date		Ø2.00mm Pin mates with Ø2.05mm Plug					
18th December 2014							
By	AJO	Tolerances (Except as Noted)		Units:		 3rd Angle Projection	
Detail	Drawing Release	Length		Metric (mm)			
Revision	A1	± 0.3		± 2°			
Date	06/01/15						