

H
G
F
E
D
C
B
A

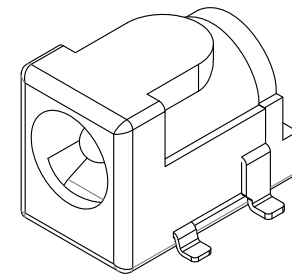
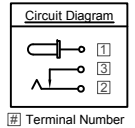
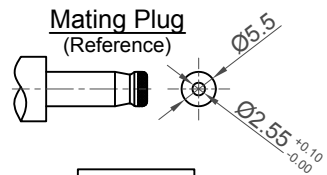
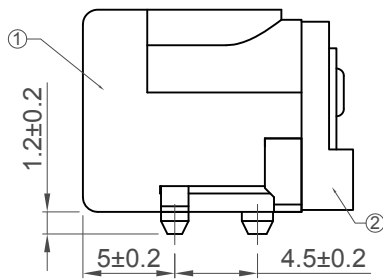
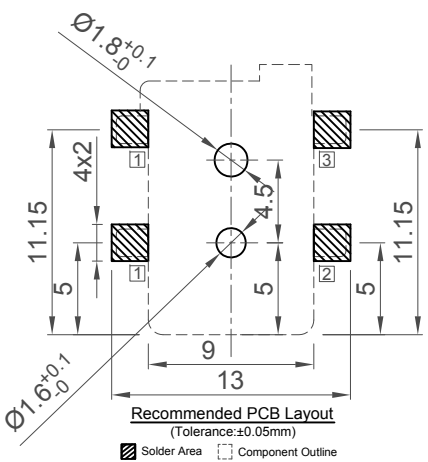
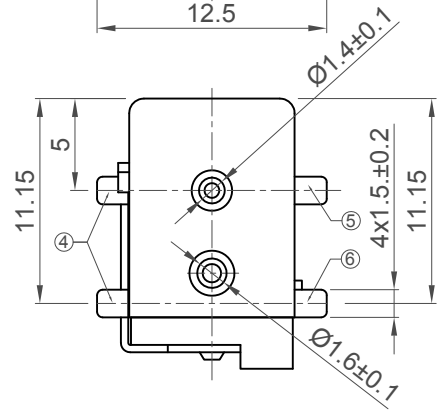
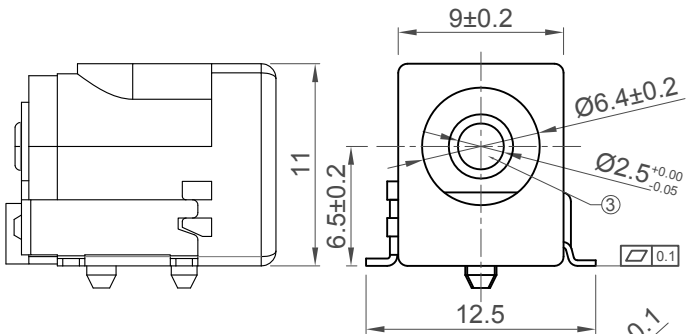
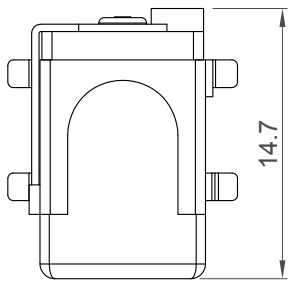
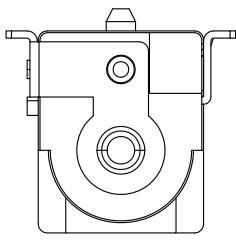

Specifications 规格

Electrical 电气规格

- Voltage Rating 电压额定值: 20 V DC
- Current Rating 电流额定值: 5 Amp
- Insulation Resistance 绝缘电阻值: 100 MΩ min.
- Dielectric Withstanding 耐电压: 500 V AC
- Contact Resistance 接触电阻值: 30 mΩ max.

Mechanical & Environmental 机械 & 环境

- Operating Temperature 工作温度: -20°C to +70°C
- Durability 耐久性: 5,000 cycles min.

No.	Description	Material	Q'ty
①	Housing	PA9T, UL94 V-0, Black	1
②	Cover	PA9T, UL94 V-0, Black	1
③	Centre Pin	① Copper alloy, Cu-Sn plating	1
④	Centre Pin Terminal	① Brass, Silver plating	1
⑤	Tip Spring	② Phosphor Bronze, Silver plating	1
⑥	Shunt Terminal	③ Brass, Silver plating	1

Ordering Grid

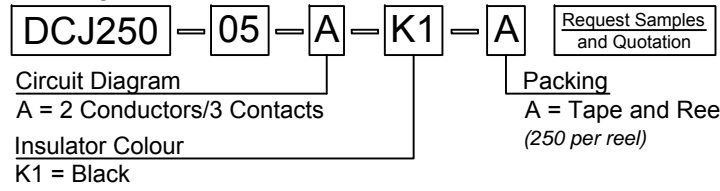

Part Number DCJ250-05		Product Description DC Power Jack, SMT, Horizontal, w/Locating Pegs			This drawing is confidential and copyright of Global Connector Technology, Ltd (GCT). This drawing must not be copied or disclosed without written consent. E & OE
Drawing Date 18th December 2014		Ø2.5mm Pin mates with Ø2.55mm Plug			
By AJO	Detail Drawing Release	Tolerances (Except as Noted) Length: ± 0.3	Angle: ± 2°	Units: Metric (mm)	
Revision A1	Date 06/01/15				Not to Scale Drawn By AJO Sheet No. 1/2

GCT
Global Connector Technology
www.gct.co

Part Number	PCS/Reel	Reels/Carton	PCS/Carton
DCJ250-05	250	12	3000

Net Weight/Carton: 6.54kg, Gross Weight/Carton: 11.38kg

Reel 外觀尺寸圖 Fig 3.

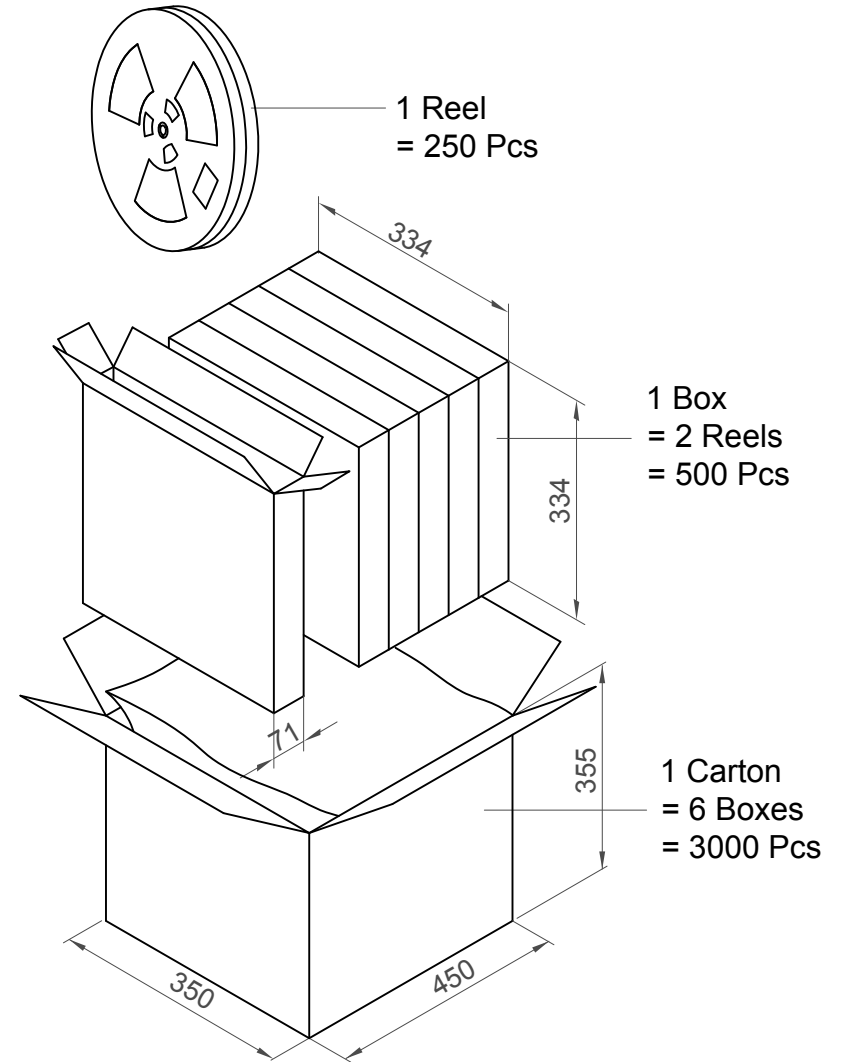

Fig 1.

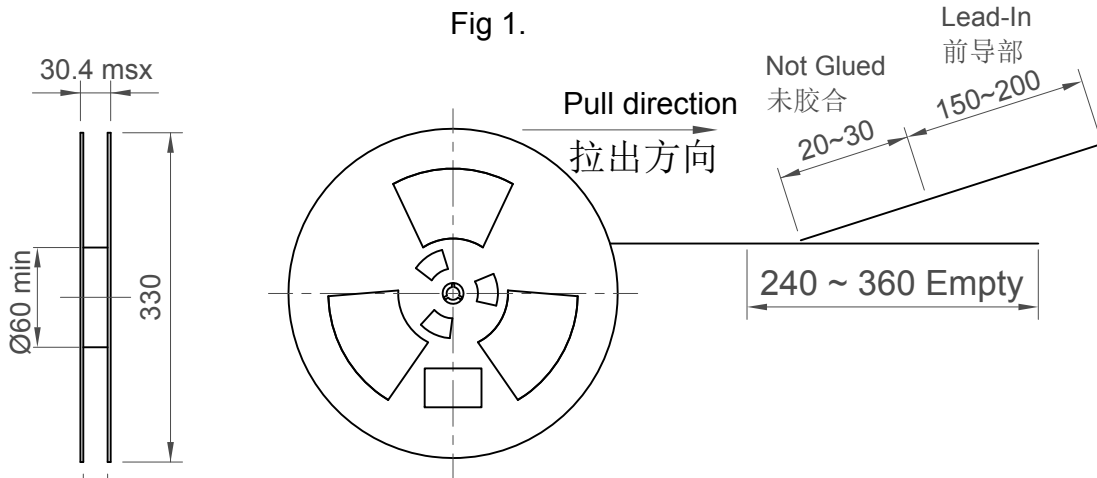
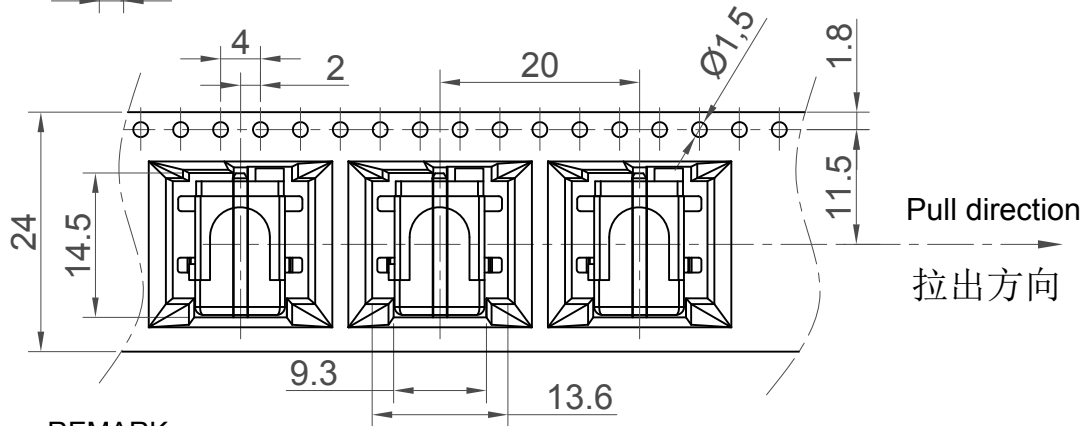

Fig 2.



REMARK:

1. Before packing, keep 160mm empty in the front carriers, don't need to pack, after packed, keep 400mm empty in the back carriers, and let cover tapes keep the same length to the carriers. (Refer to the Figure 1 and 2).
2. When packing, must set the machine according to the Operating Standard (as temperature, air pressure, speed etc), and it can't occur worn, joint etc.
3. When placing the product, can't occur the wrong direction, leakage and shortage etc for the defective status.

4. About the packing number, 250 pcs/reel, 2 reels/box, 6 boxes/carton, the total numbers are 3000 pcs per carton, if it isn't full of the carton, put the empty box in until full.
5. When sticking the label: Stick the label on the reel right side, as Figure 4, don't need to stick for the PE Bag, about the carton's label as Figure 4.

Part Number		Product Description		 		 This drawing is confidential and copyright of Global Connector Technology, Ltd (GCT). This drawing must not be copied or disclosed without written consent. E & OE		GCT Global Connector Technology www.gct.co	
DCJ250-05		DC Power Jack, SMT, Horizontal, w/Locating Pegs							
Drawing Date		Ø2.5mm Pin mates with Ø2.55mm Plug							
18th December 2014									
By	AJO	Tolerances (Except as Noted)		Units:	 3rd Angle Projection		Not to Scale Drawn By AJO Sheet No. 2/2		
Detail	Drawing Release	Length	Angle	Metric (mm)					
Revision	A1	± 0.3	± 2°						
Date	06/01/15								