

1-1418469-1 AS SHOWN  
 1-1418469-1 wie gezeigt

LOC	DIST	REVISIONS ÄNDERUNGEN			
P	LYR	DESCRIPTION BESCHREIBUNG	DATE	OWN	APVD
AI	-				
G		DETAIL SEE PCN E-08-027092	20FEB2009	DM	CE
G1		DETAILS SEE PCN E-10-007388	06APR2010	CRG	JG
H		DETAILS SEE PCN E-11-004256	01MAR2011	MN	SKR
J		DETAILS SEE PCN E-12-007625	24MAY2012	MN	SKR

SLIDE IN LOCKED POSITION  
 Schieber in Verriegelungsposition

DELIVERY CONDITION:  
 Lieferzustand:

SECONDARY LOCKING AND SLIDE  
 IN PRE-LOCKED POSITION  
 2. Kontaktsicherung und Schieber  
 in Vorraststellung

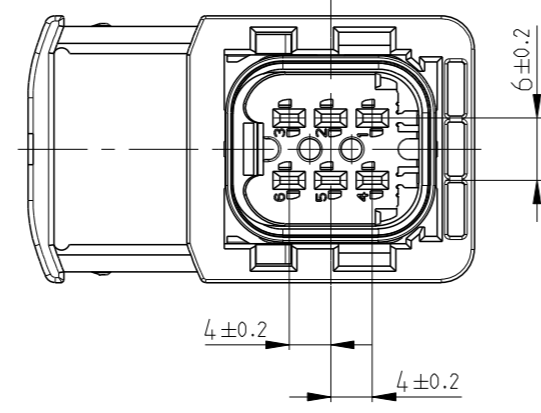
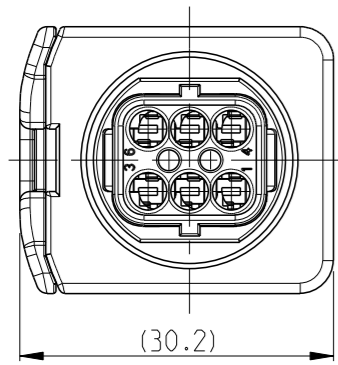

CODING A  
 Kodierung  
 PN 1-1418469-1

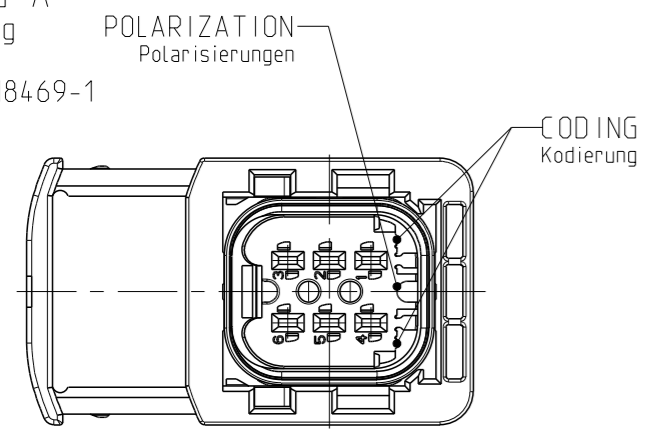

CODING B  
 Kodierung  
 PN 2-1418469-1

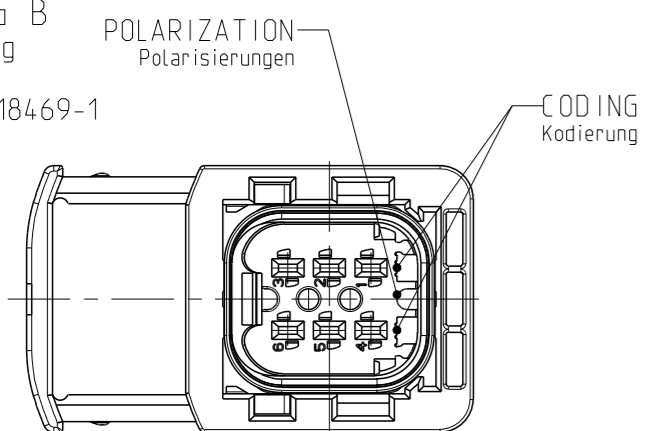

CODING C  
 Kodierung  
 PN 3-1418469-1

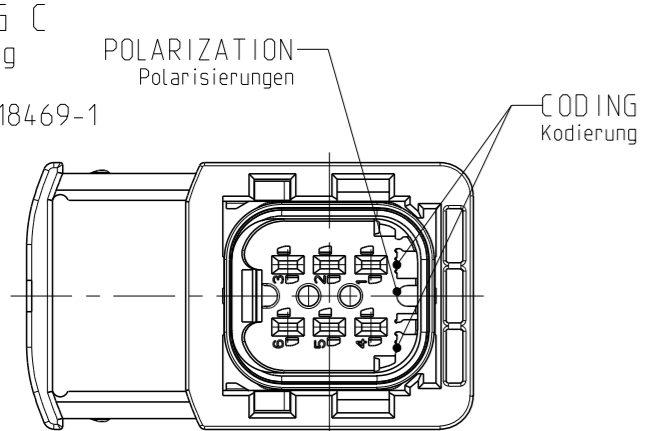

CODING D  
 Kodierung  
 PN 4-1418469-1

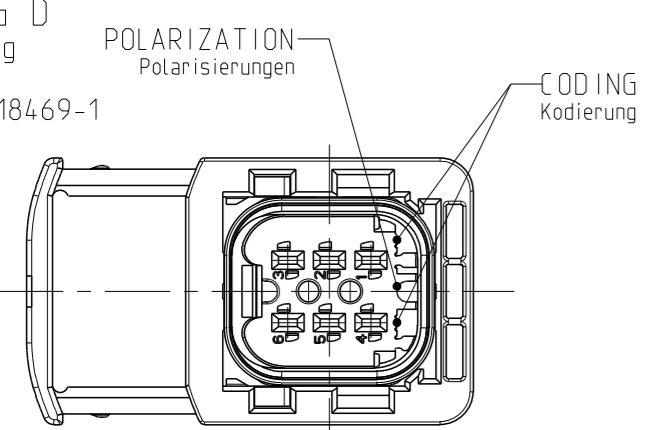

SECTION A-A  
 Schnitt

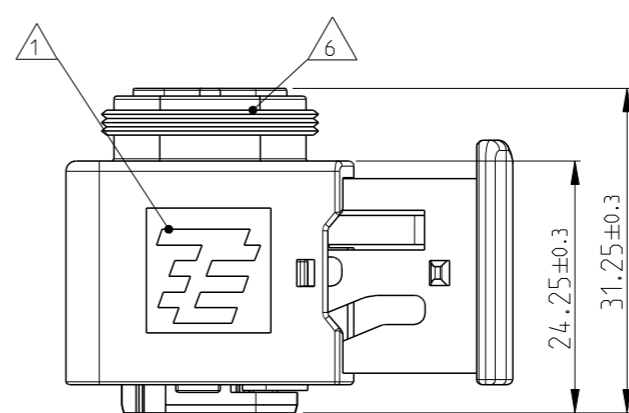
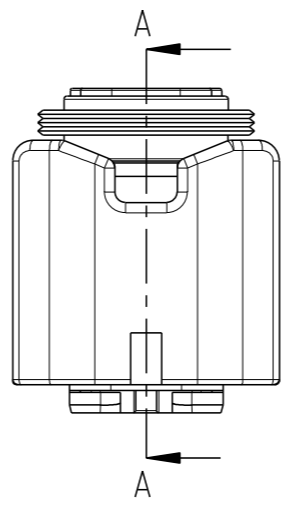
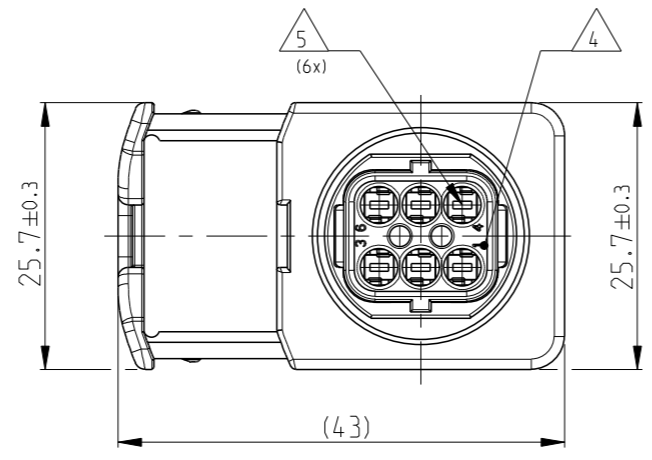
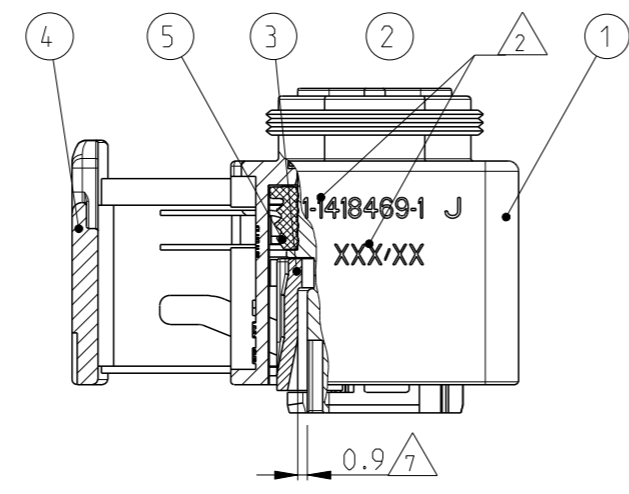

NOTES  
 Bemerkungen

- 1 TE LOGO  
TE Logo
- 2 ASSY PN. AND PRODUCTION DATE (CALENDAR DAY/YEAR):  
ASSY No. und Produktionsdatum (Kalendertag/Jahr):  
Laserbeschriftung
- 3 BULK PACKAGING IN CORRUGATED BOX  
Schüttgut im Versandkarton
- 4 CAVITY NUMBERING  
Kammer Bezeichnung
- 5 CAVITIES MATED WITH AMP MCP 1.5  
SEE PRODUCT GROUP DRAWING  
TE NO: 1241436  
MAX. WIRE SIZE: 1.5mm<sup>2</sup> FLR (AWG 16 TXL)  
Kontaktkammern passend fuer AMP MCP 1.5  
siehe Produktgruppenzeichnung  
TE Nr: 1241436  
max. Drahtgrößenbereich: 1.5mm<sup>2</sup> FLR (AWG 16 TXL)
- 6 SUITABLE COVER SEE PRODUCT GROUP DRAWING: 1563709  
Passende Kappen siehe Produktgruppenzeichnung: 1563709
- 7 SLIDING DISTANCE OF SECONDARY LOCKING  
Verschiebeweg der 2. Kontaktsicherung
- 8 FITS TO TE INTERFACE DRAWING 114-18739-1  
Passend zur Ausführungsvorschrift 114-18739-1
- 9 SUITABLE COUNTERPART SEE DRAWING: 1703820, 1703773  
passendes Gegenstück siehe Zeichnung: 1703820, 1703773
- 10 MALFUNCTION CAUSED BY LACQUER IS NOT  
COVERED BY TYCO ELECTRONICS WARRANTY.  
Funktionsbeeinträchtigung durch Lackieren liegt nicht im  
Einfluss und Gewährleistungsumfang von Tyco Electronics.

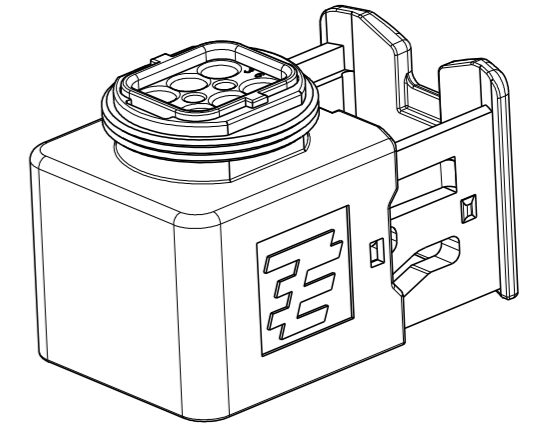

TE ORDER-NO. TE Bestell-Nr.	REV.	NO. OF POS. Polzahl	CODE Kodierung	COLOR OF CAVITY BLOCK Farbe des Kammerblocks	QUANTITY Stueck	ITEM NO ASSY	DESCRIPTION Beschreibung
4-1418469-1	J	6	D	BLUE blau	1	4	REFLECTIVE HOUSING Reflexiergehäuse
3-1418469-1	J	6	C	GREEN grün	1	3	APPS. CAVITY BLOCK, CODE, "A" opt. Kammerblock, Kodierung, "A"
2-1418469-1	J	6	B	GREY grau	1	2	APPS. CAVITY BLOCK, CODE, "B" opt. Kammerblock, Kodierung, "B"
1-1418469-1	J	6	A	BLACK schwarz	1	1	APPS. CAVITY BLOCK, CODE, "C" opt. Kammerblock, Kodierung, "C"
				BLUE blau	1	1	APPS. CAVITY BLOCK, CODE, "D" opt. Kammerblock, Kodierung, "D"
				YELLOW gelb	1	1	SECONDARY LOCKING DEVICE 2. Kontaktsicherung
				WHITE weiß	1	1	SEAL Dichtung

<p>THIS DRAWING IS A CONTROLLED DOCUMENT FOR THE TYCO ELECTRONICS CORPORATION                  IT IS SUBJECT TO CHANGE AND THE CUSTOMER SHOULD BE CONTACTED FOR THE LATEST REVISION                  DIESER ZEICHNUNG BEZUG NEHMEN AUF DIE TYCO ELECTRONICS CORPORATION                  DIESE ZEICHNUNG KANN VERÄNDERT WERDEN UND DER KUNDEN SOLLTE FÜR DIE NEUESTE REVISION                  KONTAKT MIT DER TYCO ELECTRONICS CORPORATION GEWÄRTET WERDEN</p>	<p>FOR DIMENSIONS UNLESS OTHERWISE SPECIFIED:                  ACC. TO ISO 9001-140                  DIMENSIONS:                  MASSEN: METR.                  UNITS: MILLIMETERS</p>	<p>OTHERWISE SPECIFIED:                  ACC. TO DIN 9130-140                  DIMENSIONS:                  MASSEN: METR.                  UNITS: MILLIMETERS</p>	<p>FOR DIMENSIONS UNLESS OTHERWISE SPECIFIED:                  ACC. TO ISO 9001-140                  DIMENSIONS:                  MASSEN: METR.                  UNITS: MILLIMETERS</p>	<p>FOR DIMENSIONS UNLESS OTHERWISE SPECIFIED:                  ACC. TO ISO 9001-140                  DIMENSIONS:                  MASSEN: METR.                  UNITS: MILLIMETERS</p>
<p>OWN: D. Bischoff                  APVD: J. Granzow                  PRODUCT SPEC: 108-94020                  APPLICATION SPEC: 114-18756</p>	<p>DATE: 03AUG2006                  04AUG2006                  04AUG2006</p>	<p>NAME: J. Granzow                  NAME: J. Granzow                  NAME: J. Granzow</p>	<p>NAME: J. Granzow                  NAME: J. Granzow                  NAME: J. Granzow</p>	<p>NAME: J. Granzow                  NAME: J. Granzow                  NAME: J. Granzow</p>