

DESCRIPTION: MALE - CRIMP AND LOAD

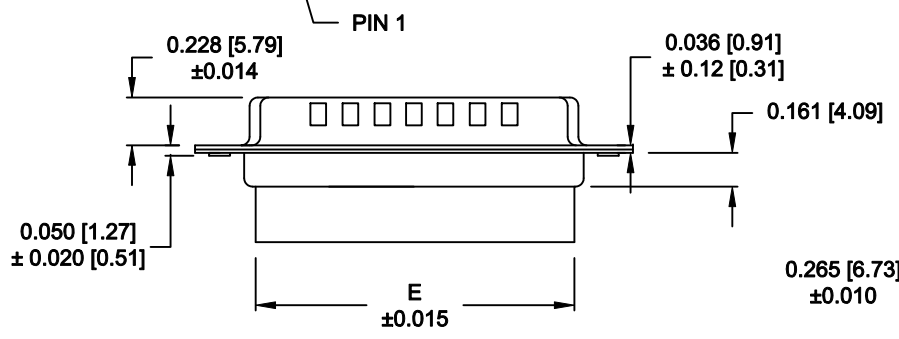
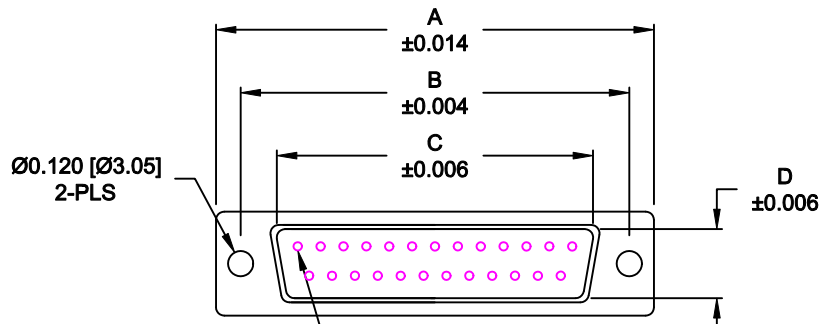

No. OF PINS	DIMENSIONS						
	A	B	C	D	E	F	G
9	1.213	0.984	0.669	0.331	0.618	0.496	0.429
	30.80	24.99	17.00	8.40	15.70	12.60	10.90
15	1.541	1.312	0.996	0.331	0.933	0.496	0.429
	39.15	33.32	25.30	8.40	23.70	12.60	10.90
25	2.088	1.852	1.535	0.331	1.496	0.496	0.429
	53.04	47.04	39.00	8.40	38.00	12.60	10.90
37	2.729	2.500	2.181	0.331	2.142	0.496	0.429
	69.32	63.50	55.40	8.40	54.40	12.60	10.90
50	2.635	2.406	2.079	0.437	2.039	0.602	0.535
	66.93	61.11	52.80	11.10	51.80	15.30	13.60

MATERIAL:

SHELL: STEEL, TIN OR NICKEL PLATED
 INSULATOR: UL 94V-O RATED, PBT +30% FIBER-GLASS

ELECTRICAL:

CURRENT RATING: 5 AMPS
 CONTACT RESISTANCE: 15 mOhms Max.
 INSULATION RESISTANCE: 1,000 MOhms min.
 VOLTAGE: 500VAC FOR 1 MINUTE
 TEMPERATURE: -50° C TO 125° C

RoHS COMPLIANT

170-YYY-17YL000

SERIES _____
 POSITIONS _____
 009 _____
 015 _____
 025 _____
 037 _____
 050 _____
 GENDER _____
 1 = MALE
 TERMINATION _____
 7 = CRIMP & LOAD
 SHELL PLATING _____
 2 = TIN
 3 = NICKEL (GROUND INDENTS)
 RoHS COMPLIANT _____
 HARDWARE OPTIONS _____
 00 = NO HARDWARE
 01 = .098" CLINCH NUT (BOARD SIDE)
 02 = .236" CLINCH NUT (BOARD SIDE)
 03 = .236" CLINCH NUT (MATING SIDE)
 PLATING OPTIONS _____
 0 = NO CONTACTS

DO NOT SCALE FROM DRAWING

	THESE DRAWINGS AND SPECIFICATIONS ARE THE PROPERTY OF NorComp AND SHALL NOT BE REPRODUCED, COPIED OR USED AS THE BASIS FOR THE MANUFACTURE OF SALE OF APPARATUS WITHOUT WRITTEN PERMISSION.		DRAWN: PAM JENKINS	DATE: 8-18-98
			CHECKED:	DATE:
NorComp		SCALE: 1 : 1	SHEET 1 OF 2	REV 9
		DWG NO. 170-YYY-17YL000		

ALL CLINCH-NUTS ARE 4-40 INTERNAL THREADS

01X 0.065" (BOARD SIDE) - CN1

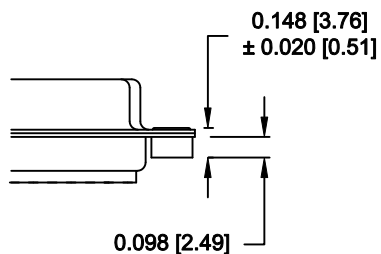

02X 0.236" (BOARD SIDE) - CN2

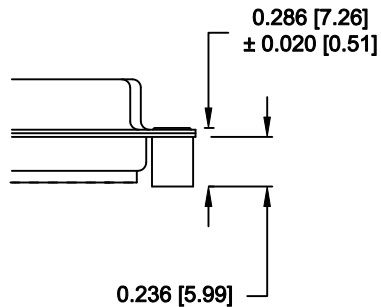

03X..... 0.236" (MATING SIDE) - CN8

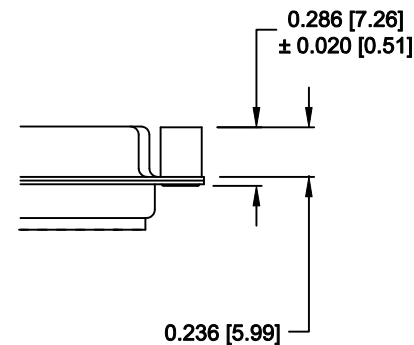

DO NOT SCALE FROM DRAWING

	THESE DRAWINGS AND SPECIFICATIONS ARE THE PROPERTY OF NorComp AND SHALL NOT BE REPRODUCED, COPIED OR USED AS THE BASIS FOR THE MANUFACTURE OF SALE OF APPARATUS WITHOUT WRITTEN PERMISSION.		DRAWN: C. SMITH	DATE: 03-08-06
			CHECKED:	DATE:
NorComp		SCALE: FULL	SHEET 2 OF 2	REV 9
		DWG NO. 170-YYY-17YL000		

RoHS COMPLIANT