

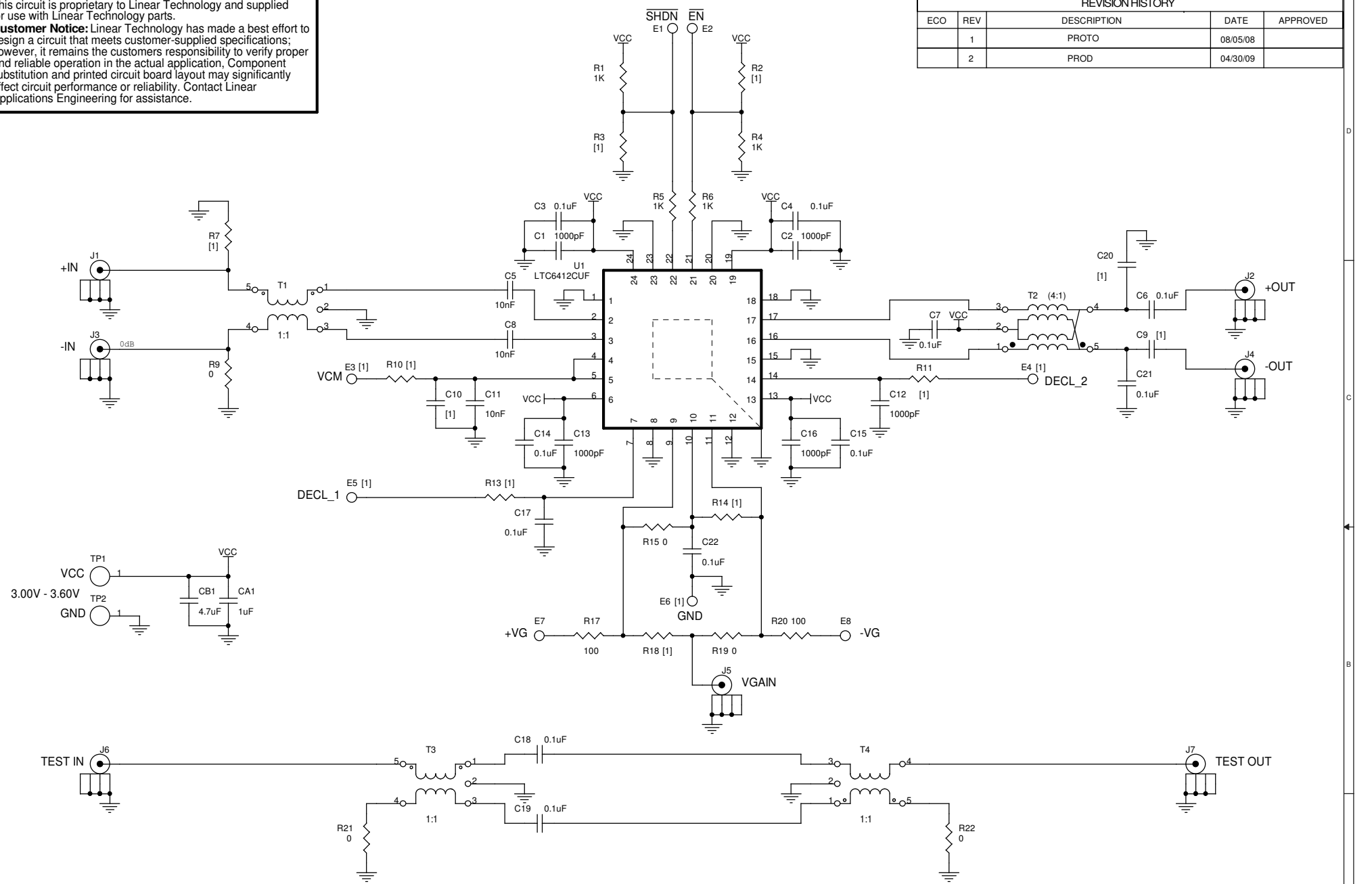

This circuit is proprietary to Linear Technology and supplied for use with Linear Technology parts.
Customer Notice: Linear Technology has made a best effort to design a circuit that meets customer-supplied specifications; however, it remains the customers responsibility to verify proper and reliable operation in the actual application. Component substitution and printed circuit board layout may significantly affect circuit performance or reliability. Contact Linear Applications Engineering for assistance.

REVISION HISTORY				
ECO	REV	DESCRIPTION	DATE	APPROVED
	1	PROTO	08/05/08	
	2	PROD	04/30/09	



NOTES: UNLESS OTHERWISE SPECIFIED,
 [1] DO NOT STUFF.

CONTRACT NO.		 1630 McCarthy Blvd. Milpitas, CA 95035 Phone: (408)432-1900 Fax: (408)434-0507	TITLE	
APPROVALS	DATE		SCH, LTC6412CJF, 800MHz ANALOG VGA	
DRAWN MI	08/05/08		SIZE	CAGE CODE
CHECKED			DWG NO	REV
APPROVED			DC1464A	2
ENGINEER		SCALE:	FILENAME: 1464a-2.dsn	SHEET 1 OF 1
DESIGNER		Thursday, April 30, 2009		