

REVISION HISTORY				
ECO	REV	DESCRIPTION	APPROVED	DATE
-	2	PRODUCTION FAB	GEORGE B.	9-17-13

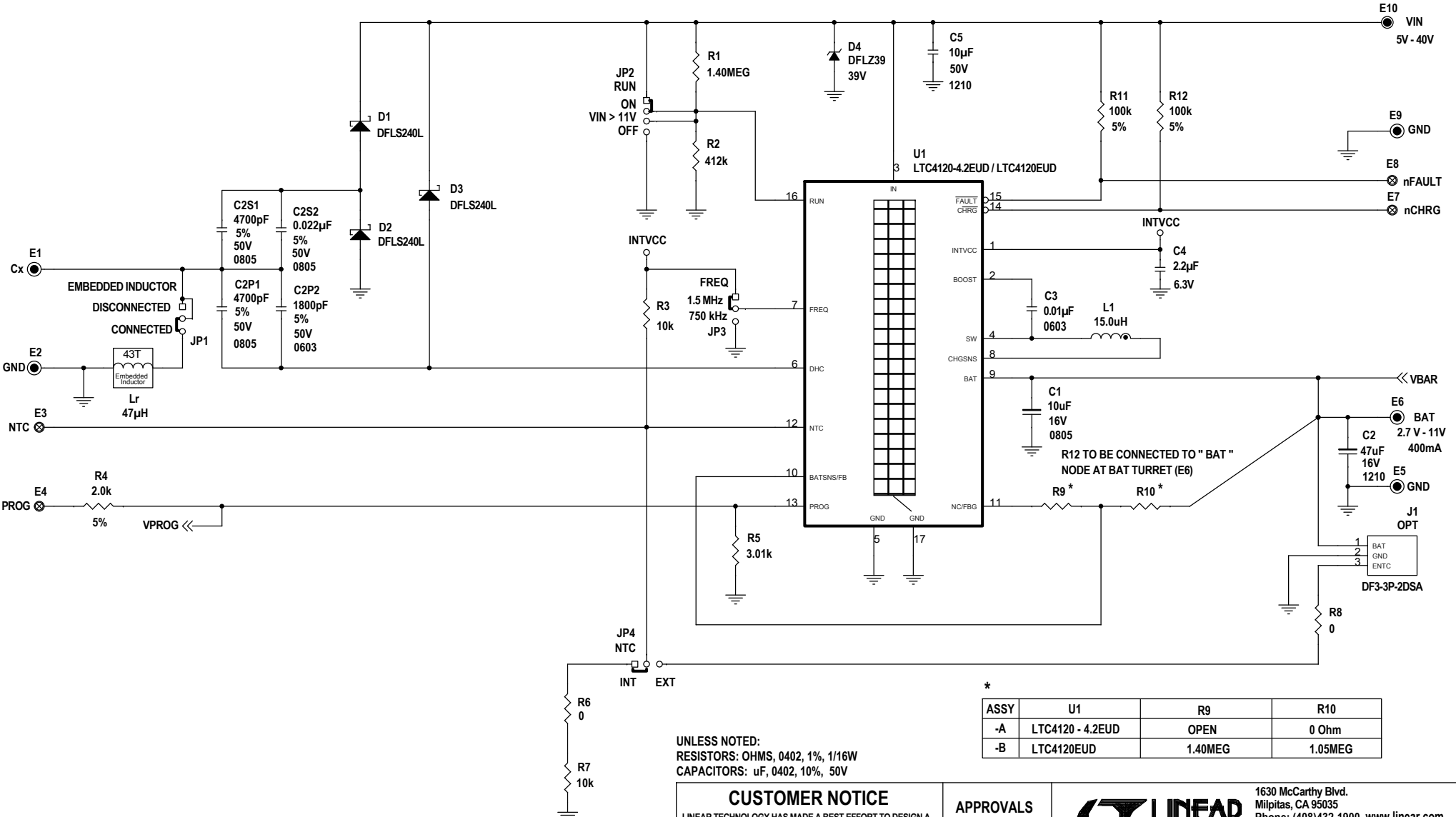

*

ASSY	U1	R9	R10
-A	LTC4120 - 4.2EUD	OPEN	0 Ohm
-B	LTC4120EUD	1.40MEG	1.05MEG

UNLESS NOTED:
 RESISTORS: OHMS, 0402, 1%, 1/16W
 CAPACITORS: uF, 0402, 10%, .50V

CUSTOMER NOTICE
 LINEAR TECHNOLOGY HAS MADE A BEST EFFORT TO DESIGN A CIRCUIT THAT MEETS CUSTOMER-SUPPLIED SPECIFICATIONS; HOWEVER, IT REMAINS THE CUSTOMER'S RESPONSIBILITY TO VERIFY PROPER AND RELIABLE OPERATION IN THE ACTUAL APPLICATION. COMPONENT SUBSTITUTION AND PRINTED CIRCUIT BOARD LAYOUT MAY SIGNIFICANTLY AFFECT CIRCUIT PERFORMANCE OR RELIABILITY. CONTACT LINEAR TECHNOLOGY APPLICATIONS ENGINEERING FOR ASSISTANCE.
 THIS CIRCUIT IS PROPRIETARY TO LINEAR TECHNOLOGY AND SUPPLIED FOR USE WITH LINEAR TECHNOLOGY PARTS.

APPROVALS

PCB DES.	NC
APP ENG.	GEORGE B.
SCALE = NONE	

LINEAR TECHNOLOGY
 1630 McCarthy Blvd.
 Milpitas, CA 95035
 Phone: (408)432-1900 www.linear.com
 Fax: (408)434-0507
 LTC Confidential-For Customer Use Only

TITLE: SCHEMATIC
400mA WIRELESS SYNCHRONOUS BUCK BATTERY CHARGER

SIZE N/A	IC NO. LTC4120 - 4.2EUD / LTC4120EUD	REV. 2
DATE: 9-17-13		SHEET 1 OF 2

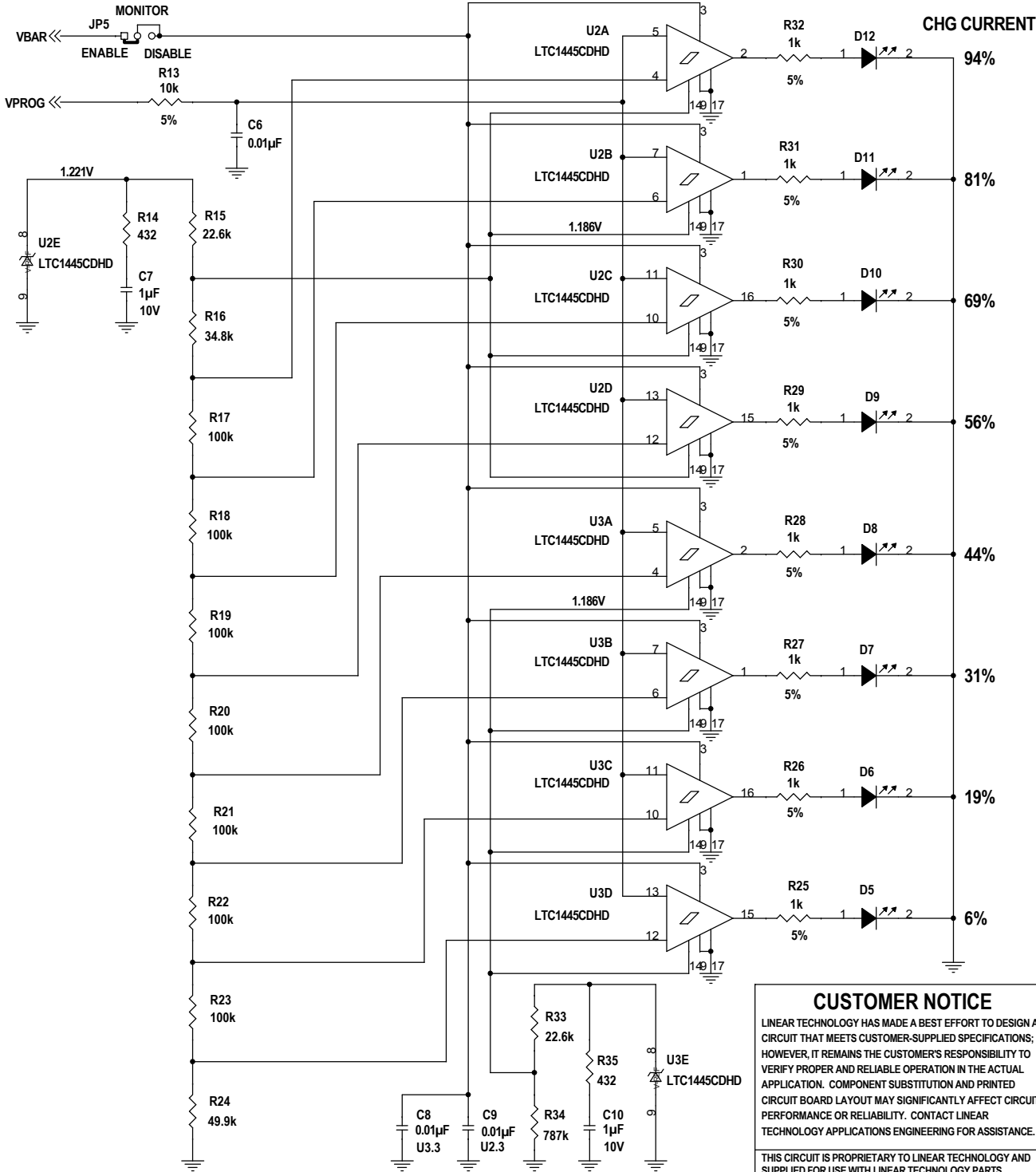

CHG CURRENT

94%
81%
69%
56%
44%
31%
19%
6%

UNLESS NOTED:
RESISTORS: OHMS, 0402, 1%, 1/16W
CAPACITORS: µF, 0402, 10%, 50V

CUSTOMER NOTICE

LINEAR TECHNOLOGY HAS MADE A BEST EFFORT TO DESIGN A CIRCUIT THAT MEETS CUSTOMER-SUPPLIED SPECIFICATIONS; HOWEVER, IT REMAINS THE CUSTOMER'S RESPONSIBILITY TO VERIFY PROPER AND RELIABLE OPERATION IN THE ACTUAL APPLICATION. COMPONENT SUBSTITUTION AND PRINTED CIRCUIT BOARD LAYOUT MAY SIGNIFICANTLY AFFECT CIRCUIT PERFORMANCE OR RELIABILITY. CONTACT LINEAR TECHNOLOGY APPLICATIONS ENGINEERING FOR ASSISTANCE.

THIS CIRCUIT IS PROPRIETARY TO LINEAR TECHNOLOGY AND SUPPLIED FOR USE WITH LINEAR TECHNOLOGY PARTS.

APPROVALS

PCB DES.	NC
APP ENG.	GEORGE B.
SCALE = NONE	

		1630 McCarthy Blvd. Milpitas, CA 95035 Phone: (408)432-1900 www.linear.com Fax: (408)434-0507 LTC Confidential-For Customer Use Only	
		TITLE: SCHEMATIC BAR GRAPH FOR 400mA WIRELESS SYNCHRONOUS BUCK BATTERY CHARGER	
SIZE N/A	IC NO. LTC4120 - 4.2EUD / LTC4120EUD	REV. 2	
DATE:	9-17-13	SHEET 2 OF 2	