

LS2-1XX-XX-XX-D-XXX-X

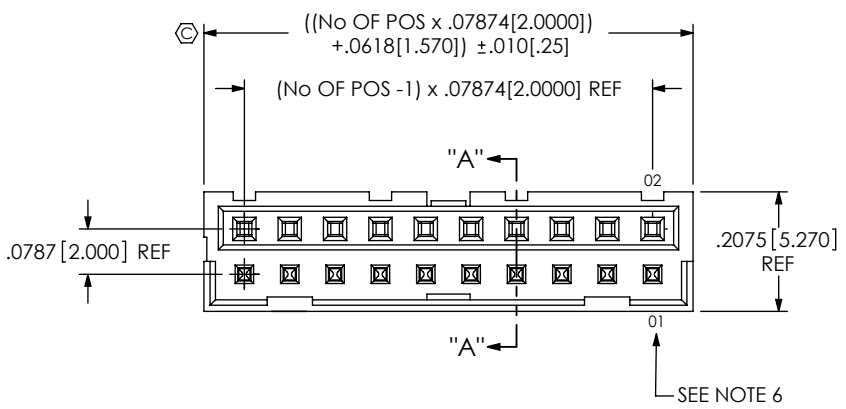
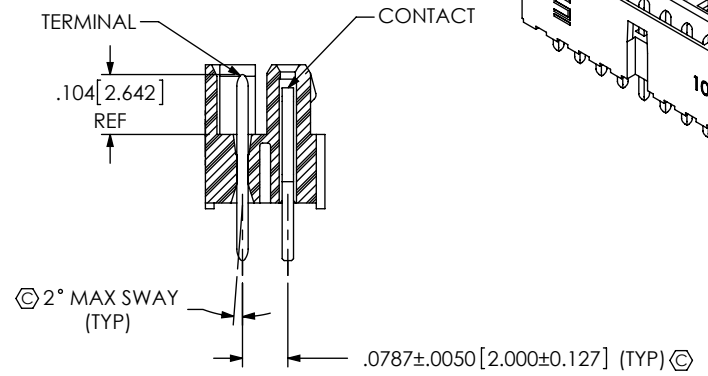
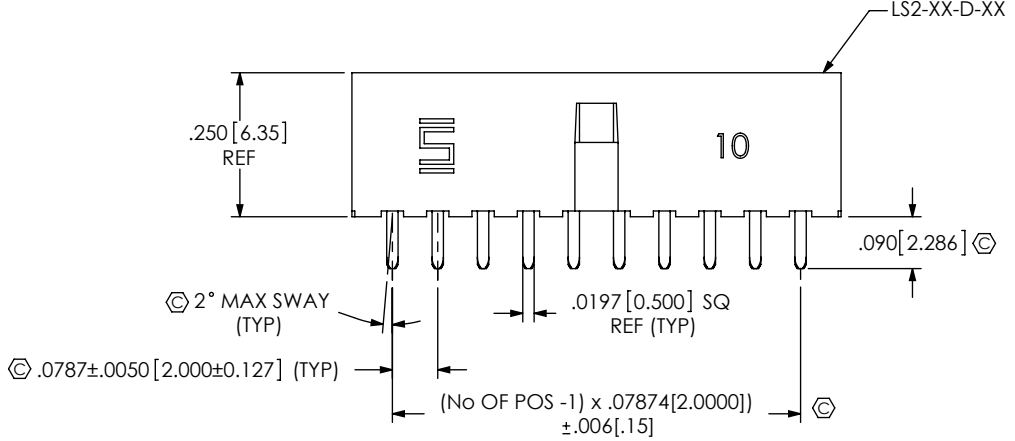



FIG 1  
LS2-110-01-X-D SHOWN

- No OF POSITIONS**  
-05, -10, -15, -20,  
-25, -30  
(PER ROW)
- LEAD STYLE**  
-01: THROUGH HOLE  
-02: SURFACE MOUNT  
(SEE FIG 2)
- PLATING SPECIFICATION**  
-F: FLASH SELECTIVE GOLD  
(USE T-1S13-XX-F-2 & C-79-XX-F)  
-FM: FLASH SELECTIVE GOLD  
MATTE TIN REMAINDER  
(USE T-1S13-XX-F-2 & C-79-XX-F)  
-L: LIGHT SELECTIVE GOLD  
(USE T-1S13-XX-L-2 & C-79-XX-L)  
-LM: LIGHT SELECTIVE GOLD  
MATTE TIN REMAINDER  
(USE T-1S13-XX-L-2 & C-79-XX-L)  
-S: SELECTIVE GOLD  
(USE T-1S13-XX-S-2 & C-79-XX-S)  
-SM: SELECTIVE GOLD  
MATTE TIN REMAINDER  
(USE T-1S13-XX-S-2 & C-79-XX-S)  
-G: GOLD  
(USE T-1S13-XX-G-2 & C-79-XX-G)  
-H: HEAVY GOLD  
(USE T-1S13-XX-H-2 & C-79-XX-H)
- OPTION**  
-K: POLYIMIDE FILM PAD  
(USE K-DOT-.246-.375-.005, SEE FIG 5)  
[LEAD STYLE -02 ONLY]  
-A: ALIGNMENT PIN  
(USE LS2-XX-D-XX-A, SEE FIG 6)  
[LEAD STYLE -02 ONLY]  
-TR: TAPE & REEL
- TAIL OPTION**  
-RA1: RIGHT ANGLE-  
SHROUD DOWN (SEE FIG 3)  
-RA2: RIGHT ANGLE-  
SHROUD UP (SEE FIG 4)  
[AVAILABLE ONLY ON LEAD STYLE -01]
- ROW SPECIFICATION**  
-D: DOUBLE (USE LS2-XX-D-XX)



STYLE	OPTION	TERMINAL	CONTACT
-01	---	T-1S13-20-XXX-2	C-79-01-XXX
	-RA1	T-1S13-03-XXX-2	C-79-12-XXX
	-RA2	T-1S13-10-XXX-2	C-79-12-XXX
-02	---	T-1S13-13-XXX-2	C-79-12-XXX

- NOTES:
- ⊕ REPRESENTS A CRITICAL DIMENSION.
  - BURR ALLOWANCE: .003[.08] MAX.
  - MAXIMUM CUT FLASH: .015[.38].
  - MINIMUM PUSHOUT FORCE; TERMINALS: 2 LBS, CONTACTS: .5 LBS.
  - MAXIMUM ALLOWABLE BOW: .002 INCH/INCH AFTER ASSEMBLY.
  - SEE APPLICATION VIEWS (SHEET 3) FOR POSITION 01 LOCATION.
  - ALL PIN TO PIN DIMENSIONS TO BE MEASURED FROM TIP TO TIP.
  - DIMENSION TO BE MEASURED AT BEND.
  - SHEAR TAILS TO DIMENSION SHOWN.

UNLESS OTHERWISE SPECIFIED, DIMENSIONS ARE IN INCHES. TOLERANCES ARE: DECIMALS      ANGLES .XX: ±.01 [.3]      2° .XXX: ±.005 [.13] .XXXX: ±.0020 [.051]	<b>PROPRIETARY NOTE</b> THIS DOCUMENT CONTAINS INFORMATION CONFIDENTIAL AND PROPRIETARY TO SAMTEC, INC. AND SHALL NOT BE REPRODUCED OR TRANSFERRED TO OTHER DOCUMENTS OR DISCLOSED TO OTHERS OR USED FOR ANY PURPOSE OTHER THAN THAT WHICH IT WAS OBTAINED WITHOUT THE EXPRESSED WRITTEN CONSENT OF SAMTEC, INC.		
		520 PARK EAST BLVD, NEW ALBANY, IN 47150 PHONE: 812-944-6733      FAX: 812-948-5047 e-Mail: info@SAMTEC.com      code: 55322	
<b>MATERIAL:</b> DO NOT SCALE DRAWING      SHEET SCALE: 3:1 INSULATOR: LCP, COLOR: BLACK SOCKET: PHOS BRONZE TERMINAL: PHOS BRONZE		DESCRIPTION: 2mm TERMINAL/SOCKET COMBO	
		DWG. NO. LS2-1XX-XX-XX-D-XXX-X	
BY: DEAN P      4/24/2002		SHEET 1 OF 4	

REVISION T

FIG 2

LS2-110-02-X-D SHOWN  
[DIFFERENT AS SHOWN, OTHERWISE SAME AS FIG. 1]

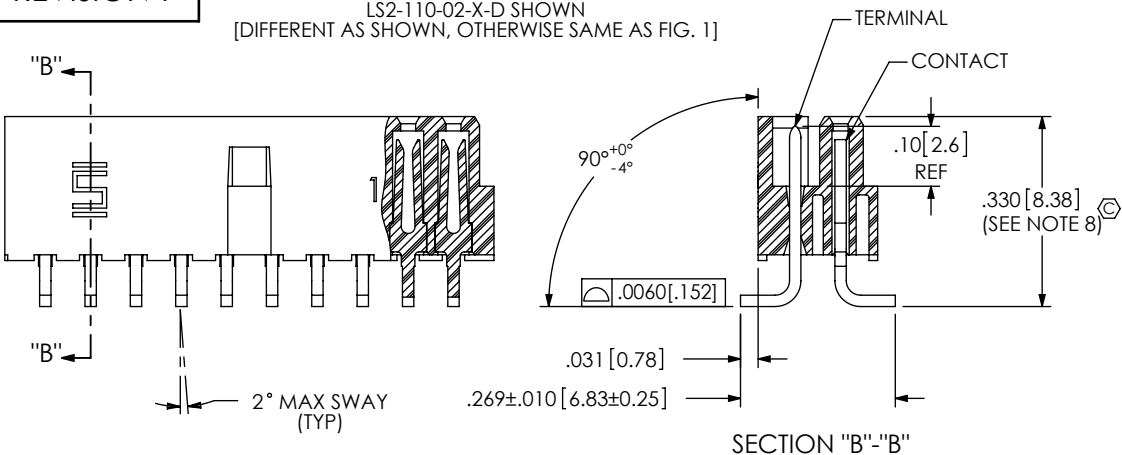

STYLE -02-D IN-PROCESS VIEWS

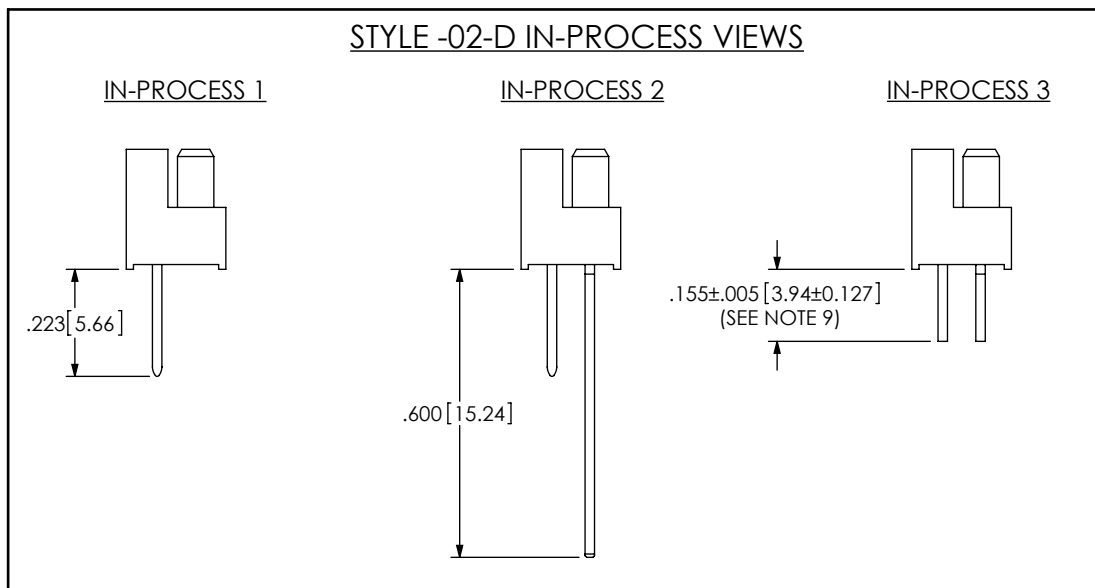
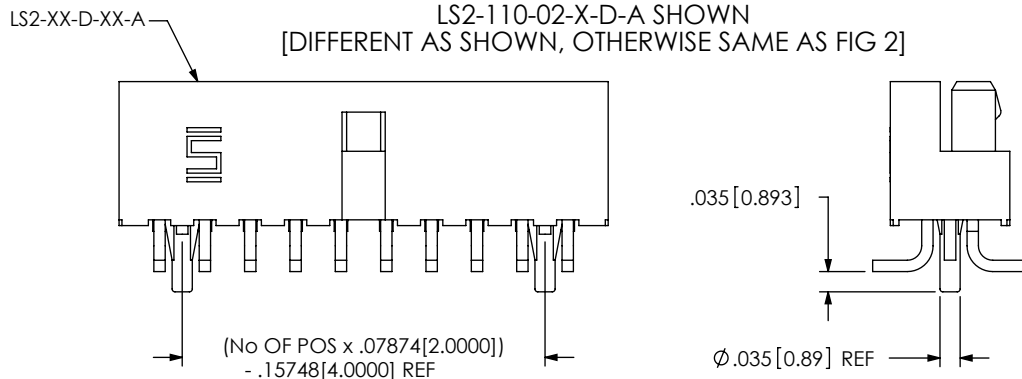

FIG 6

-A: ALIGNMENT PIN OPTION  
LS2-110-02-X-D-A SHOWN  
[DIFFERENT AS SHOWN, OTHERWISE SAME AS FIG 2]



F:\DWG\MISC\MKTG\LS2-1XX-XX-XX-D-XXX-X-MKT.SLDDRW

PACKAGING VIEWS

STYLE -01

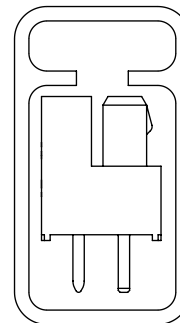

TUBE: PT-1-24-04-09  
PLUG: TP-07

STYLE -02

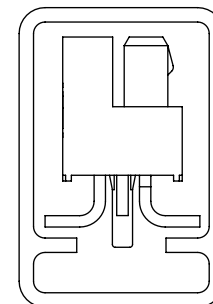

TUBE: PT-1-24-01-123  
PLUG: TP-03

STYLE -01-RA1

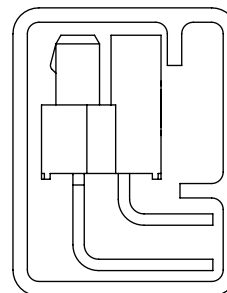

TUBE: PT-1-24-01-124  
PLUG: TP-07

STYLE -01-RA2

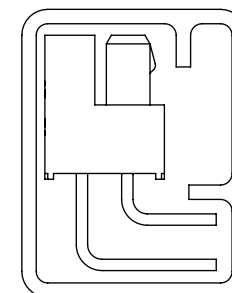

TUBE: PT-1-24-01-124  
PLUG: TP-07

PROPRIETARY NOTE

THIS DOCUMENT CONTAINS INFORMATION CONFIDENTIAL AND PROPRIETARY TO SAMTEC, INC. AND SHALL NOT BE REPRODUCED OR TRANSFERRED TO OTHER DOCUMENTS OR DISCLOSED TO OTHERS OR USED FOR ANY PURPOSE OTHER THAN THAT WHICH IT WAS OBTAINED WITHOUT THE EXPRESSED WRITTEN CONSENT OF SAMTEC, INC.

DO NOT SCALE DRAWING

SHEET SCALE: 3:1

**samtec**

520 PARK EAST BLVD, NEW ALBANY, IN 47150  
PHONE: 812-944-6733 FAX: 812-948-5047  
e-Mail: info@SAMTEC.com code: 55322

DESCRIPTION:  
2mm TERMINAL/SOCKET COMBO

DWG. NO.  
LS2-1XX-XX-XX-D-XXX-X

BY: DEAN P 4/24/2002 SHEET 2 OF 4

REVISION T

IN-PROCESS 1

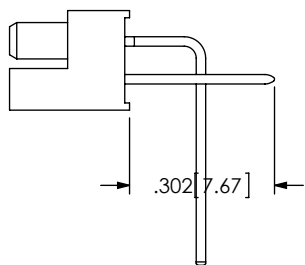

IN-PROCESS 2

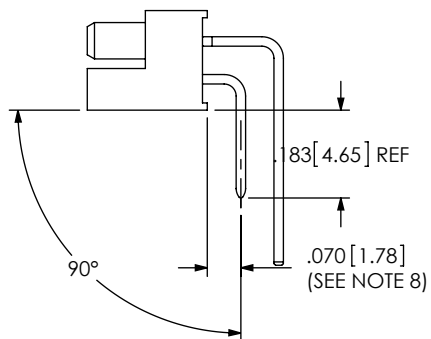

IN-PROCESS 1

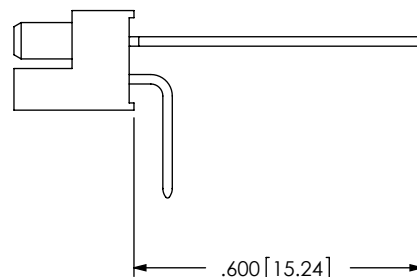

IN-PROCESS 4

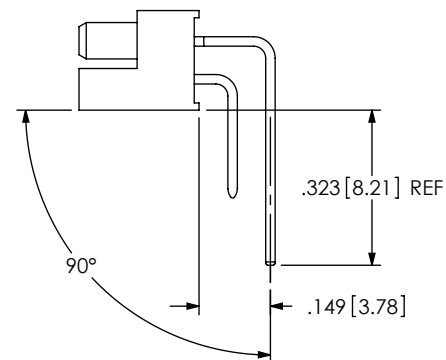

STYLE -01-RA1 IN-PROCESS VIEWS

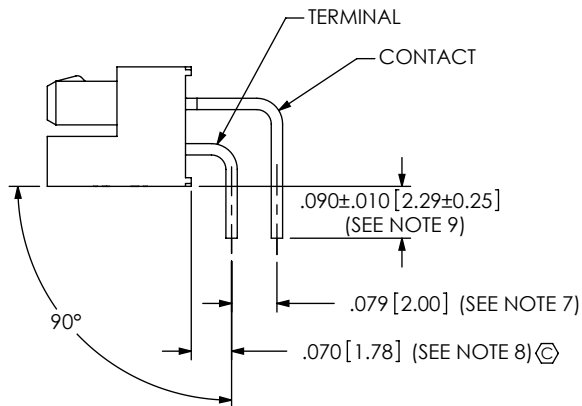
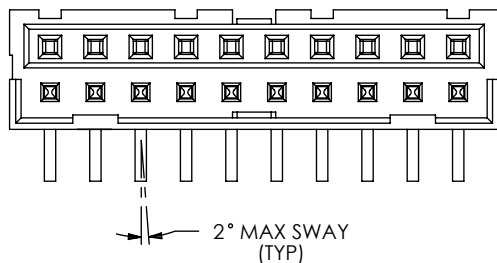
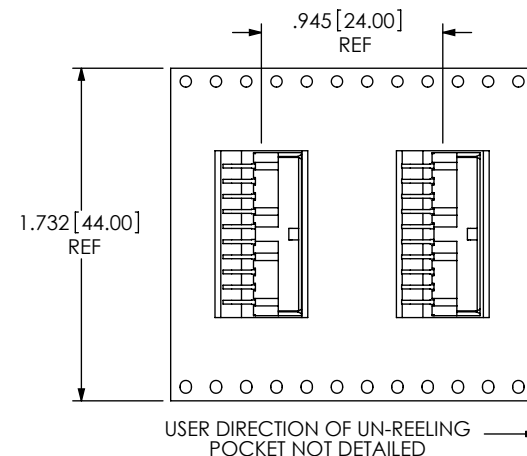
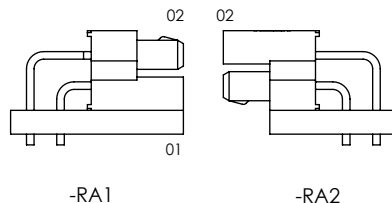
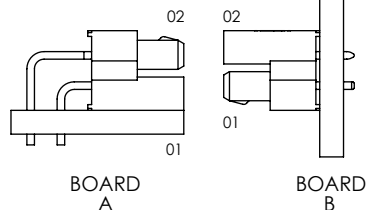
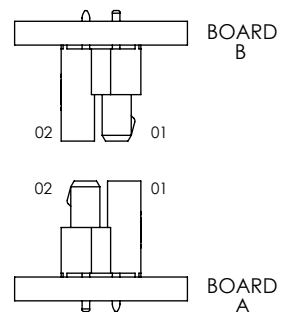

FIG 3  
LS2-110-01-X-D-RA1 SHOWN  
[DIFFERENT AS SHOWN, OTHERWISE SAME AS FIG 1]  
\* AVAILABLE ONLY ON LEAD STYLE -01 \*



STYLE-01-RA1 PACKAGING VIEW  
PARTS MUST BE ORIENTED PER THE DESIGN OF THE POCKET AND POCKET TOOL. POCKETS DESIGNED AFTER REVISION Q MUST ORIENT PARTS PER THIS VIEW.

APPLICATION VIEWS



PARALLEL BOARD-TO-BOARD

PERPENDICULAR BOARD-TO-BOARD

IN-LINE PARALLEL BOARD-TO-BOARD

F:\DWG\MISC\MKTG\LS2-1XX-XX-XX-D-XXX-X-MKT.SLDDRW

PROPRIETARY NOTE

THIS DOCUMENT CONTAINS INFORMATION CONFIDENTIAL AND PROPRIETARY TO SAMTEC, INC. AND SHALL NOT BE REPRODUCED OR TRANSFERRED TO OTHER DOCUMENTS OR DISCLOSED TO OTHERS OR USED FOR ANY PURPOSE OTHER THAN THAT WHICH IT WAS OBTAINED WITHOUT THE EXPRESSED WRITTEN CONSENT OF SAMTEC, INC.

DO NOT SCALE DRAWING

SHEET SCALE: 3:1



520 PARK EAST BLVD, NEW ALBANY, IN 47150  
PHONE: 812-944-6733 FAX: 812-948-5047  
e-Mail: info@SAMTEC.com code: 55322

DESCRIPTION: 2mm TERMINAL/SOCKET COMBO

DWG. NO. LS2-1XX-XX-XX-D-XXX-X

BY: DEAN P 4/24/2002 SHEET 3 OF 4

IN-PROCESS 1

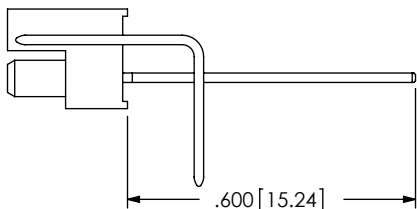

IN-PROCESS 2

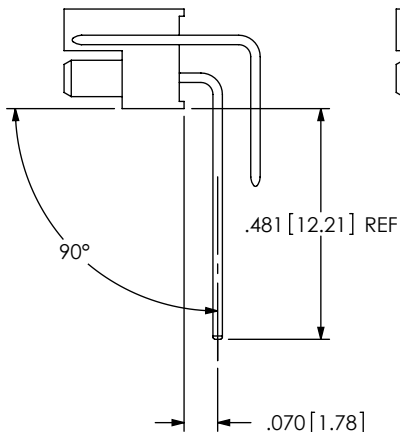

IN-PROCESS 3

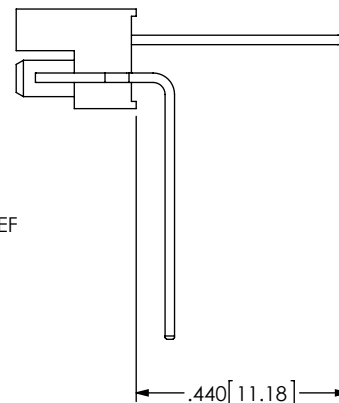

IN-PROCESS 4

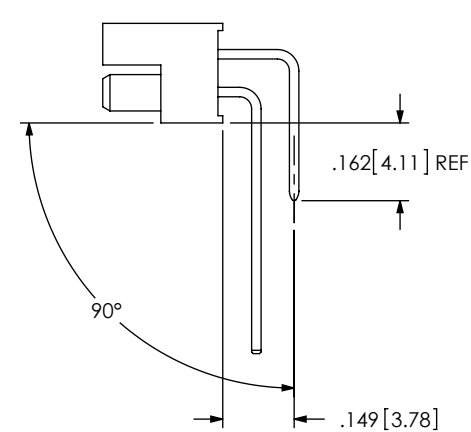

STYLE -01-RA2 IN-PROCESS VIEWS

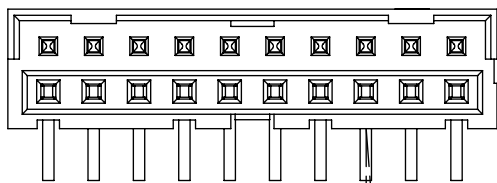

2° MAX SWAY (TYP)

FIG 4

LS2-110-01-X-D-RA2 SHOWN [DIFFERENT AS SHOWN, OTHERWISE SAME AS FIG 1]

\* AVAILABLE ONLY ON LEAD STYLE -01 \*

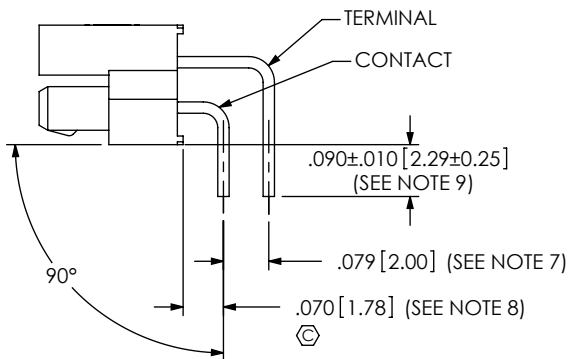
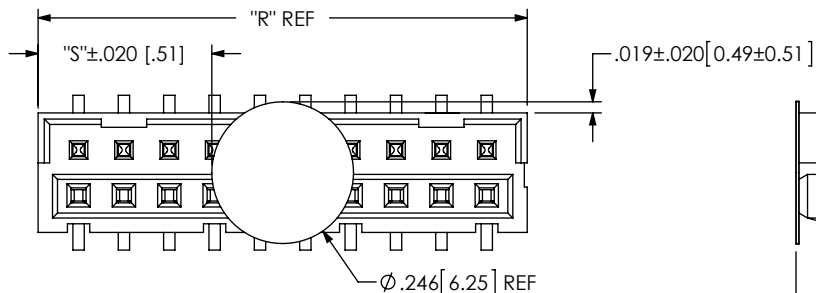
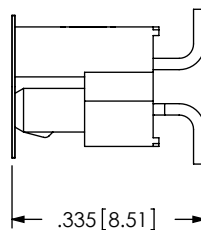

FIG 5  
-K: POLYIMIDE FILM PAD OPTION



NOTE:  
"R" = (No OF POS x .07874[2.0000]) +.06181[1.570]  
"S" = ("R" - .2460[6.248]) / 2



F:\DWG\MISC\MKTG\LS2-1XX-XX-XX-D-XXX-X-MKT.SLDDRW

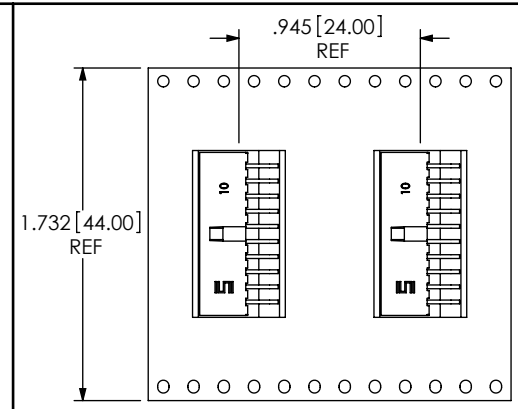

USER DIRECTION OF UN-REELING  
POCKET NOT DETAILED

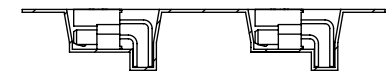

STYLE-01-RA2 PACKAGING VIEW  
PARTS MUST BE ORIENTED PER THE DESIGN OF THE POCKET AND POCKET TOOL.  
POCKETS DESIGNED AFTER REVISION Q MUST ORIENT PARTS PER THIS VIEW.

PROPRIETARY NOTE

THIS DOCUMENT CONTAINS INFORMATION CONFIDENTIAL AND PROPRIETARY TO SAMTEC, INC. AND SHALL NOT BE REPRODUCED OR TRANSFERRED TO OTHER DOCUMENTS OR DISCLOSED TO OTHERS OR USED FOR ANY PURPOSE OTHER THAN THAT WHICH IT WAS OBTAINED WITHOUT THE EXPRESSED WRITTEN CONSENT OF SAMTEC, INC.

DO NOT SCALE DRAWING

SHEET SCALE: 3:1



520 PARK EAST BLVD, NEW ALBANY, IN 47150  
PHONE: 812-944-6733 FAX: 812-948-5047  
e-Mail: info@SAMTEC.com code: 55322

DESCRIPTION: 2mm TERMINAL/SOCKET COMBO

DWG. NO. LS2-1XX-XX-XX-D-XXX-X

BY: DEAN P 4/24/2002 SHEET 4 OF 4