

DO NOT SCALE FROM THIS PRINT

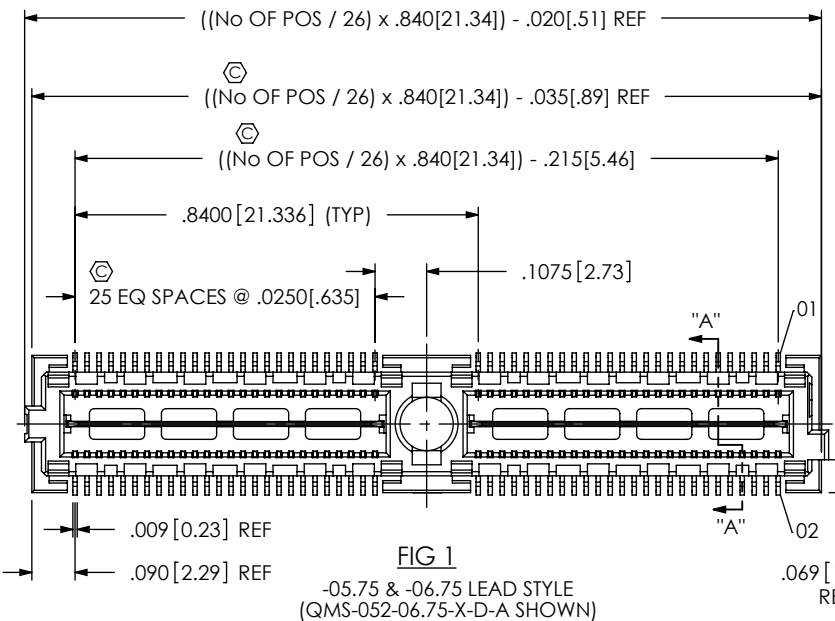

- No OF POSITIONS (PER ROW)**
-026, -052, -078, -104, * -130
- LEAD STYLE (SEE NOTE 9)**
-05.75 (SEE FIG 1)
-06.75 (SEE FIG 1)
**-09.75 (SEE FIG 4, SHEET 3)
- PLATING SPECIFICATION**
-H: 30μ" GOLD IN CONTACT AREA, 3μ" GOLD ON TAIL. (AVAILABLE ON -05.75 & -06.75 LEAD STYLE ONLY)
-L: 10μ" GOLD IN CONTACT AREA, MATTE TIN ON TAIL. (AVAILABLE ON -05.75 & -06.75 LEAD STYLE ONLY)
-S: 30μ" GOLD IN CONTACT AREA, MATTE TIN ON TAIL. (AVAILABLE ON -09.75 LEAD STYLE ONLY)
-SL: 10μ" GOLD IN CONTACT AREA, MATTE TIN ON TAIL. (AVAILABLE ON -09.75 LEAD STYLE ONLY)
- ROW SPECIFICATION**
-D: DOUBLE
- OPTION**
-A: ALIGNMENT PIN
-GP: GUIDE POSTS (SEE FIG 3, SHEET 2) (AVAILABLE ON -05.75 & -06.75 LEAD STYLES ONLY)
-K: KAPTON PAD (SEE FIG 2, SHEET 2)
- (OPTIONS NOT AVAILABLE IN COMBINATION WITH -PXX OR -RFX)

- PACKAGING OPTION**
-TR: TAPE & REEL PACKAGING (-026 THRU -078 WITH NO OPTIONS) (-026 & -052 WITH -GP, -PXX, -RF1, -RT1) (-026 WITH RF2)
- END OPTION**
-PC4: POWER COMBO 4 (.062" THICK BOARD) (SEE FIG 5, SHEET 4)
-PC8: POWER COMBO 8 (.062" THICK BOARD) (SEE FIG 5, SHEET 4)
-PT4: POWER COMBO 4 (.093" THICK BOARD) (SEE FIG 5, SHEET 4)
-PT8: POWER COMBO 8 (.093" THICK BOARD) (SEE FIG 5, SHEET 4)
-RF1: 1 RF POS PER END (SEE FIG 6, SHEET 5)
-RF2: 2 RF POS PER END (SEE FIG 7, SHEET 5)
-RT1: 1 RT POS PER END (SEE FIG 8, SHEET 6)
- (-PXX & -RFX NOT AVAILABLE IN COMBINATION WITH -A, -GP, OR -K) (END OPTION APPLIES TO BOTH ENDS, COMBINATIONS ARE NOT AVAILABLE) (-PXX & -RFX AVAILABLE IN POS -026, -052, & -078 ONLY) (-RFX & -RT1 AVAILABLE ON -05.75 LEAD STYLE ONLY) (-RT1 AVAILABLE IN -026, -052, -078, & -104 POS WITH -A OPTION ONLY) (-PXX AVAILABLE ON -05.75 & -06.75 LEAD STYLES ONLY)**

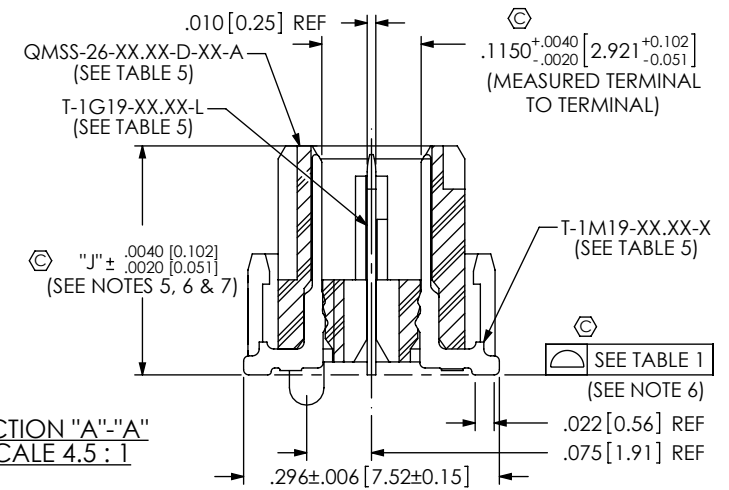
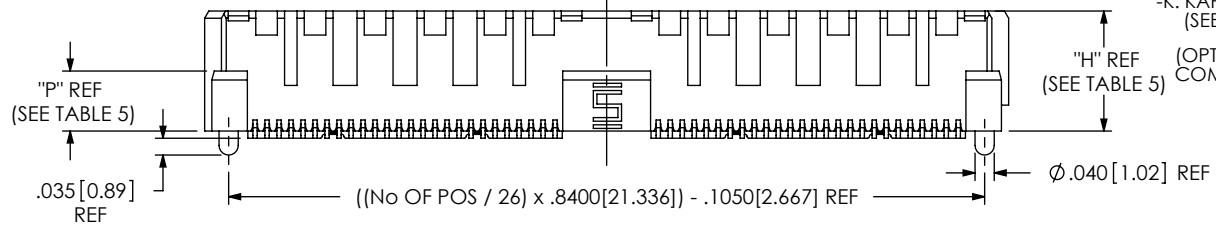

* = NOT TOOLED
** = SEE NOTE 10

TABLE 5

LEAD STYLE	"H"	"J"	"P"	QMS BODY	QMS STACKER BODY	TERMINAL	GROUND PLANE	MATED TO QFS-XX-XX
-05.75	.212 [5.38]	.2268 [5.761]	.085 [2.16]	QMSS-26-05.75-D-XX-A	N/A	T-1M19-05.75-XX	T-1G19-05.75-L	QFS-04.25 QFS-06.25
-06.75	.250 [6.35]	.2650 [6.731]	.125 [3.18]	QMSS-26-06.75-D-XX-A	N/A	T-1M19-06.75-XX	T-1G19-06.75-L	QFS-04.25 QFS-06.25
-09.75	.368 [9.35]	.3830 [9.728]	.085 [2.16]	QMSS-26-05.75-D-XX	QTSH-26-01-D-XX-A	T-1M19-09.75-XX	T-1G19-09.75-L	QFS-04.25 QFS-06.25

TABLE 1

No OF POSITIONS	No OF BANKS	COPLANARITY
-026 AND -052	1 AND 2	.004[.10]
-078 THRU *-130	3 THRU 5	.006[.15]

* = NOT TOOLED

SEE NOTE 4

- NOTES:
- ⊙ REPRESENTS A CRITICAL DIMENSION.
 - BURR ALLOWANCE: .0015 MAX.
 - MINIMUM PUSHOUT FORCE: SIGNAL: .5 LB, GROUND: 1 LB, POWER: .5 LB, RF: .5 LB.
 - ALL TERMINALS ON THE -05.75 & -06.75 LEAD STYLES WILL BE SHEARED.
 - MAX VARIANCE OF .002.
 - DIMENSION APPLIES TO CONTACTS & GROUND PLANE.
 - GROUND PLANE PRESS HEIGHT MUST BE .003[.08] LESS THAN THE MAX HEIGHT OR .001[.03] GREATER THAN THE MINIMUM HEIGHT OF THE TERMINALS.
 - PARTS TO BE PACKAGED IN TRAYS.
 - LEADSTYLES -10 AND -11 MAY BE SUBSTITUTED IN PART CALLOUT FOR -05.75 AND -06.75 ACCORDINGLY FOR EXISTING CUSTOMERS ONLY.
 - 09.75 LEAD STYLE -078 AND -104 POSITION AVAILABLE TO EXISTING CUSTOMERS ONLY.

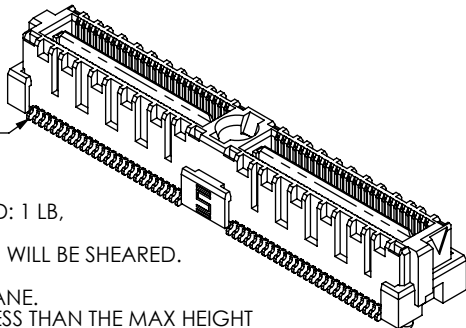

UNLESS OTHERWISE SPECIFIED, DIMENSIONS ARE IN INCHES.
TOLERANCES ARE:
DECIMALS ANGLES
.XX: ±.01 [.3] 2°
.XXX: ±.005 [.13]
.XXXX: ±.0020 [.051]

PROPRIETARY NOTE
THIS DOCUMENT CONTAINS INFORMATION CONFIDENTIAL AND PROPRIETARY TO SAMTEC, INC. AND SHALL NOT BE REPRODUCED OR TRANSFERRED TO OTHER DOCUMENTS OR DISCLOSED TO OTHERS OR USED FOR ANY PURPOSE OTHER THAN THAT WHICH IT WAS OBTAINED WITHOUT THE EXPRESSED WRITTEN CONSENT OF SAMTEC, INC.

MATERIAL: DO NOT SCALE DRAWING SHEET SCALE: 1:0.4
INSULATOR: LCP, UL 94V-0; COLOR: BLACK
TERMINAL & GROUND PLANE: PHOS BRONZE

samtec
520 PARK EAST BLVD, NEW ALBANY, IN 47150
PHONE: 812-944-6733 FAX: 812-948-5047
e-Mail: info@SAMTEC.com code: 53322

DESCRIPTION:
.635mm DOUBLE ROW TERMINAL STRIP
DWG. NO.
QMS-XXX-XX.XX-XX-D-XX-XXX-XX

BY: E.L.S. 10-12-2010 SHEET 1 OF 6

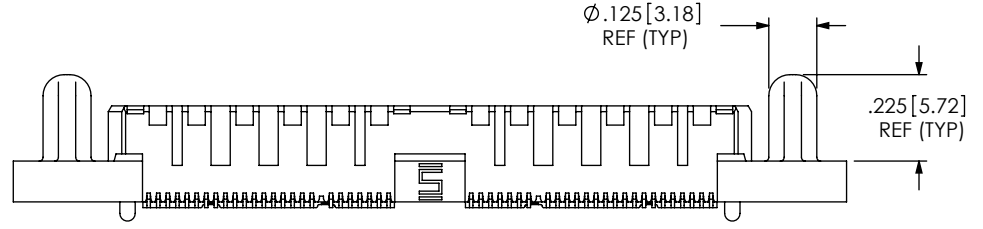
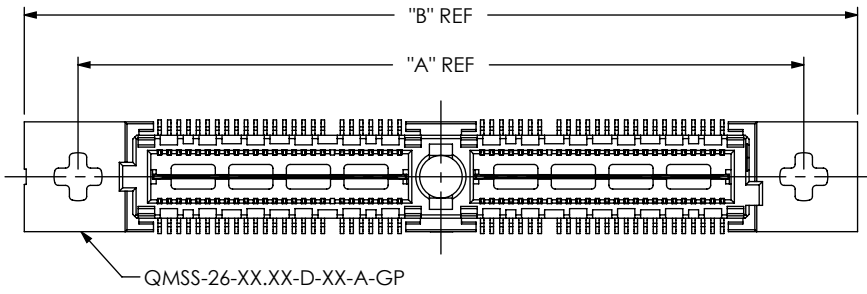
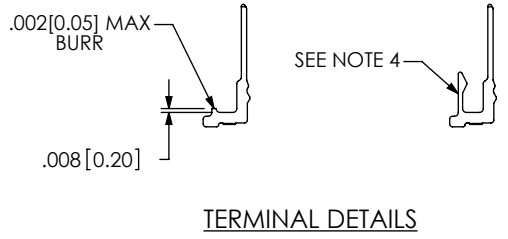
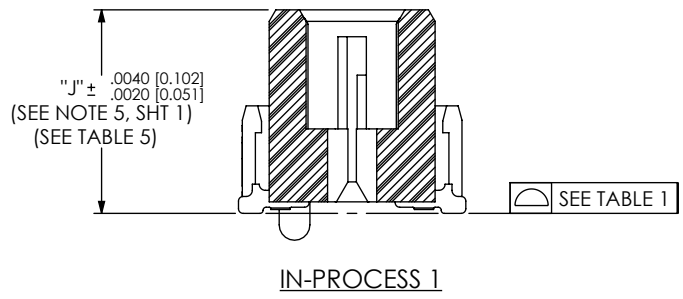

FIG 3
 -GP: GUIDE POST OPTION
 (QMS-052-06.75-X-D-A-GP SHOWN)
 (AVAILABLE ON -05.75 & -06.75 LEAD STYLES ONLY)

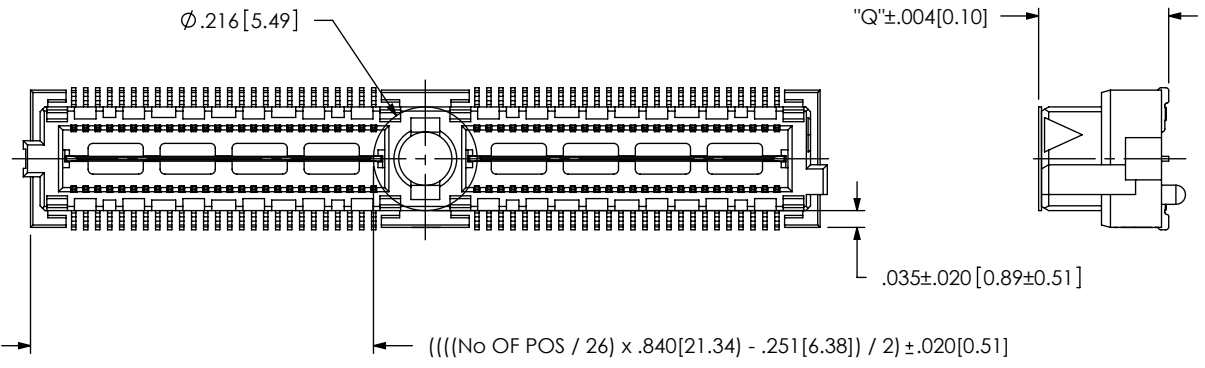

FIG 2
 -K: KAPTON PAD OPTION
 (USE K-500-300)
 (USE K-DOT-217-.313-.005 FOR -GP OPTION, NOT APPROVED
 FOR VISION INTEGRATED KAPTON APPLICATION)
 (QMS-052-06.75-X-D-A-K SHOWN)

TABLE 9	
LEAD STYLE	"Q"
-05.75	.233 [5.91]
-06.75	.271 [6.88]
-09.75	.389 [9.88]

TABLE 2		
ASSEMBLY	"A"	"B"
QMS-026-XX-X-D-A-GP	1.050 [26.67]	1.330 [33.78]
QMS-052-XX-X-D-A-GP	1.890 [48.00]	2.170 [55.12]
QMS-078-XX-X-D-A-GP	2.730 [69.34]	3.010 [76.45]
QMS-104-XX-X-D-A-GP	3.570 [90.68]	3.850 [97.79]
* QMS-130-XX-X-D-A-GP	4.410 [112.01]	4.690 [119.13]

*** NOT TOOLED**

PROPRIETARY NOTE
 THIS DOCUMENT CONTAINS INFORMATION
 CONFIDENTIAL AND PROPRIETARY TO
 SAMTEC, INC. AND SHALL NOT BE REPRODUCED
 OR TRANSFERRED TO OTHER DOCUMENTS OR
 DISCLOSED TO OTHERS OR USED FOR ANY
 PURPOSE OTHER THAN THAT WHICH IT WAS
 OBTAINED WITHOUT THE EXPRESSED WRITTEN
 CONSENT OF SAMTEC, INC.

DO NOT SCALE DRAWING
 SHEET SCALE: 1:0.4



520 PARK EAST BLVD, NEW ALBANY, IN 47150
 PHONE: 812-944-6733 FAX: 812-948-5047
 e-Mail: info@SAMTEC.com code: 55322

DESCRIPTION:
 .635mm DOUBLE ROW TERMINAL STRIP

DWG. NO.
QMS-XXX-XX.XX-XX-D-XX-XXX-XX

BY: E.L.S. 10-12-2010 SHEET 2 OF 6

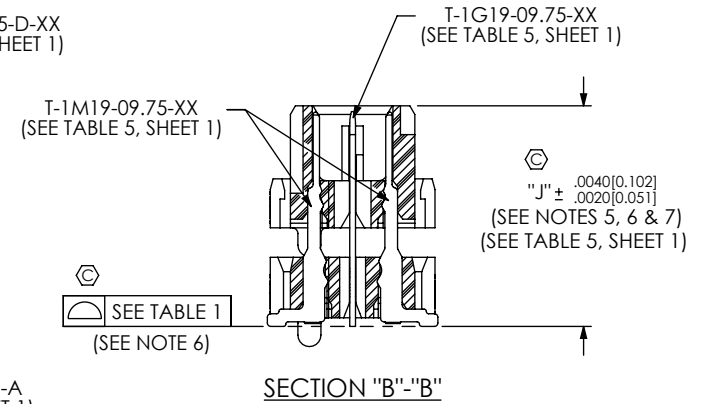
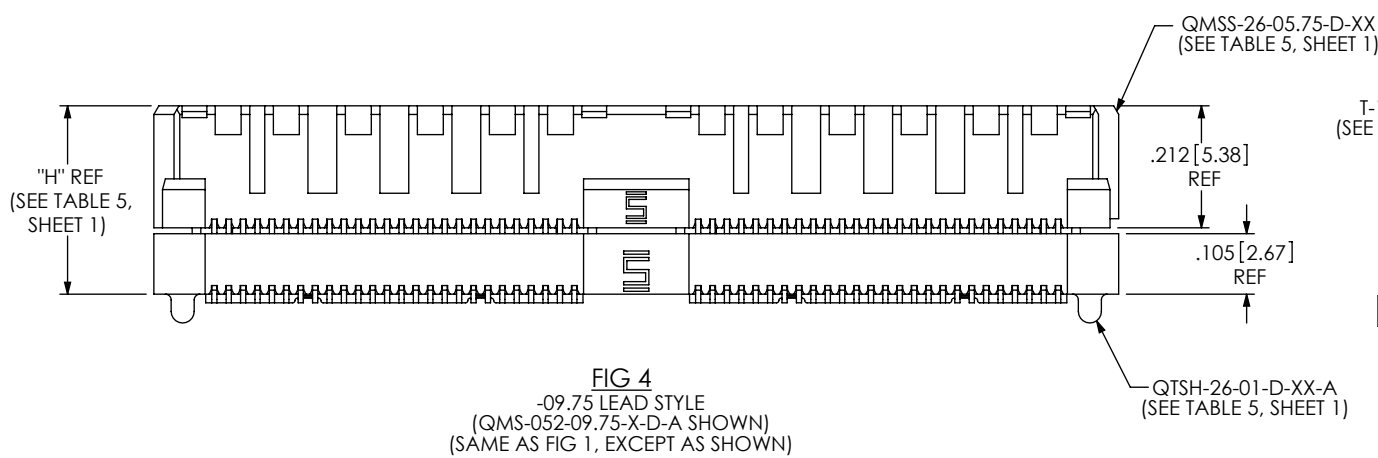
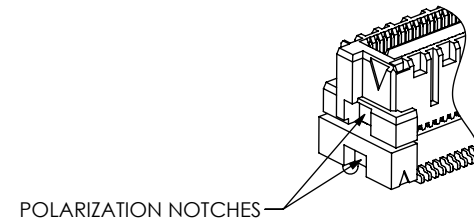
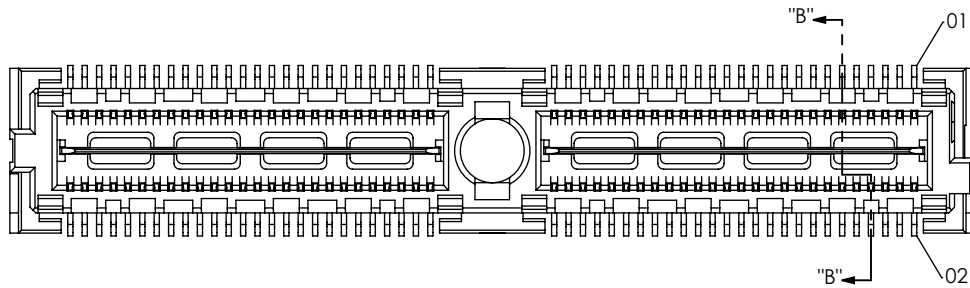

PROPRIETARY NOTE

THIS DOCUMENT CONTAINS INFORMATION CONFIDENTIAL AND PROPRIETARY TO SAMTEC, INC. AND SHALL NOT BE REPRODUCED OR TRANSFERRED TO OTHER DOCUMENTS OR DISCLOSED TO OTHERS OR USED FOR ANY PURPOSE OTHER THAN THAT WHICH IT WAS OBTAINED WITHOUT THE EXPRESSED WRITTEN CONSENT OF SAMTEC, INC.

DO NOT SCALE DRAWING

SHEET SCALE: 3:1

samtec

520 PARK EAST BLVD, NEW ALBANY, IN 47150
PHONE: 812-944-6733 FAX: 812-948-5047
e-Mail: info@SAMTEC.com code: 55322

DESCRIPTION:

.635mm DOUBLE ROW TERMINAL STRIP

DWG. NO.

QMS-XXX-XX.XX-XX-D-XX-XXX-XX

BY: E.L.S.

10-12-2010

SHEET 3 OF 6

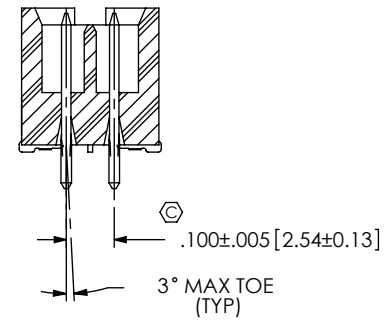
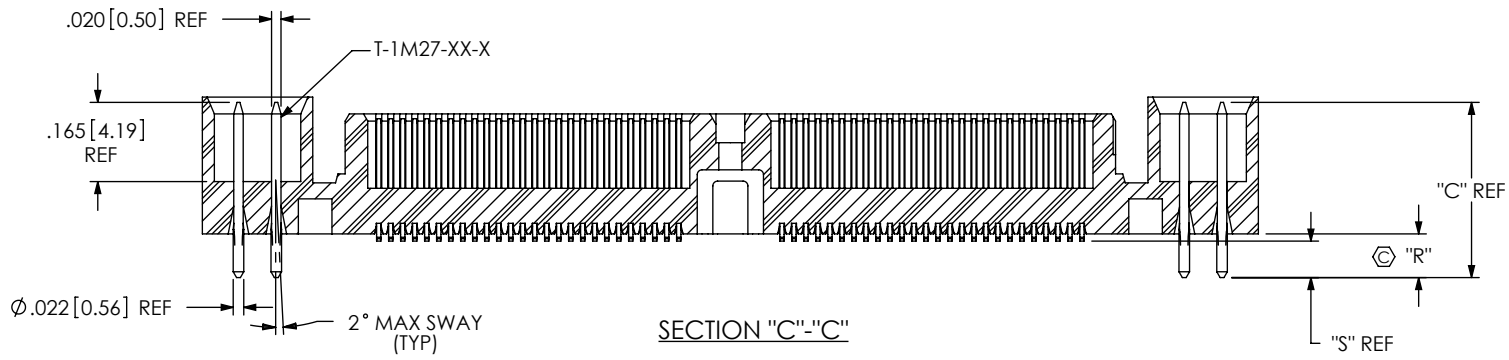
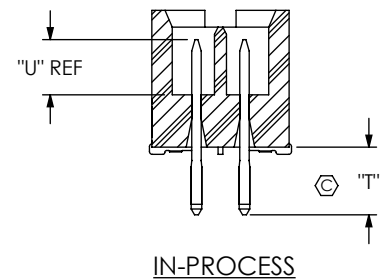
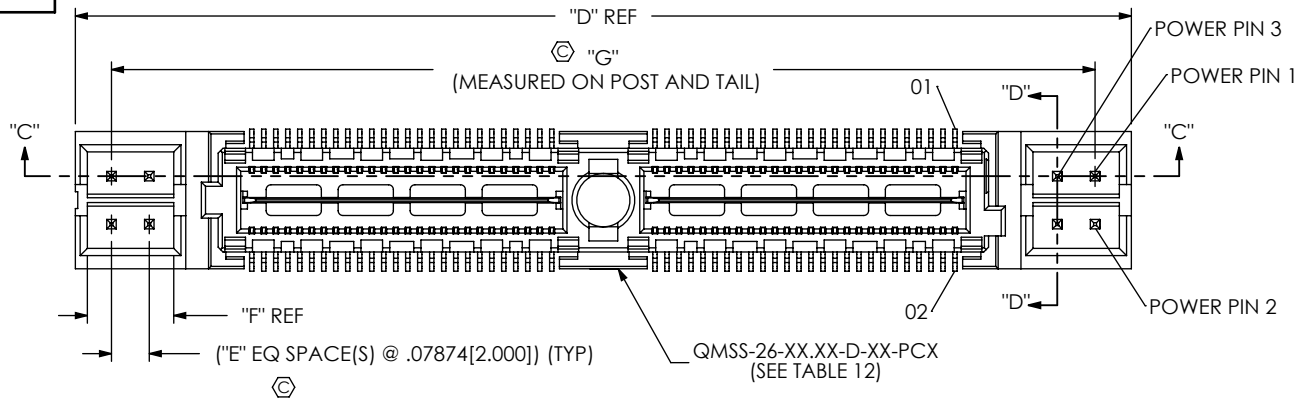

FIG 5
 -PXX OPTION
 POWER COMBO OPTIONS
 QMS-052-06.75-X-D-PC4 SHOWN
 (SAME AS FIG 1, UNLESS OTHERWISE STATED)
 [NOT AVAILABLE WITH -A, -GP OR -K OPTION, AVAILABLE ON LEAD STYLES -05.75 & -06.75 ONLY]
 (AVAILABLE ON -026, -052 & -078 POSITIONS ONLY)

ASSEMBLY	"D"	"E"	"F"	"G"
QMS-026-XX.XX-X-D-X-PX4	1.360[34.54]	1	.180[4.57]	1.209[30.71]
QMS-026-XX.XX-X-D-X-PX8	1.675[42.55]	3	.337[8.56]	1.524[38.71]
QMS-052-XX.XX-X-D-X-PX4	2.200[55.88]	1	.180[4.57]	2.049[52.04]
QMS-052-XX.XX-X-D-X-PX8	2.515[63.88]	3	.337[8.56]	2.364[60.05]
QMS-078-XX.XX-X-D-X-PX4	3.040[77.22]	1	.180[4.57]	2.889[73.38]
QMS-078-XX.XX-X-D-X-PX8	3.355[85.22]	3	.337[8.56]	3.204[81.38]

LEAD STYLE	POWER OPTION	BODY
-06.75	PX4	QMS-26-06.75-D-XX-PC4
-06.75	PX8	QMS-26-06.75-D-XX-PC8
-05.75	PX4	QMS-26-05.75-D-XX-PC4
-05.75	PX8	QMS-26-05.75-D-XX-PC8

LEAD STYLE	POWER OPTION	TERMINAL	"C"	"R"	"S"	"T"	"U"
-06.75	PCX	T-1M27-01-S	.365[9.27]	.091[2.31]	.076[1.93]	.132[3.35]	.124[3.15]
-06.75	PTX	T-1M27-03-S	.400[10.16]	.126[3.20]	.111[2.82]	.132[3.35]	.159[4.04]
-05.75	PCX	T-1M27-02-S	.326[8.28]	.086[2.18]	.071[1.80]	.172[4.37]	.079[2.01]
-05.75	PTX	T-1M27-01-S	.365[9.27]	.125[3.18]	.110[2.79]	.172[4.37]	.118[3.00]

PROPRIETARY NOTE
 THIS DOCUMENT CONTAINS INFORMATION CONFIDENTIAL AND PROPRIETARY TO SAMTEC, INC. AND SHALL NOT BE REPRODUCED OR TRANSFERRED TO OTHER DOCUMENTS OR DISCLOSED TO OTHERS OR USED FOR ANY PURPOSE OTHER THAN THAT WHICH IT WAS OBTAINED WITHOUT THE EXPRESSED WRITTEN CONSENT OF SAMTEC, INC.

DO NOT SCALE DRAWING
 SHEET SCALE: 1:0.4



520 PARK EAST BLVD, NEW ALBANY, IN 47150
 PHONE: 812-944-6733 FAX: 812-948-5047
 e-Mail: info@SAMTEC.com code: 55322

DESCRIPTION:
 .635mm DOUBLE ROW TERMINAL STRIP

DWG. NO.
QMS-XXX-XX.XX-XX-D-XX-XXX-XX

BY: E.L.S. 10-12-2010 SHEET 4 OF 6

TABLE 7			
ASSEMBLY	QMSS-26-05.75-D-XX-RFX	"K"	"L"
QMS-026-05.75-X-D-RF1	QMSS-26-05.75-D-01-RF1	1.425[36.20]	1.153[29.29]
QMS-026-05.75-X-D-RF2	QMSS-26-05.75-D-01-RF2	1.925[48.90]	1.653[41.99]
QMS-052-05.75-X-D-RF1	QMSS-26-05.75-D-02-RF1	2.265[57.53]	1.993[50.62]
QMS-052-05.75-X-D-RF2	QMSS-26-05.75-D-02-RF2	2.765[70.23]	2.493[63.32]
QMS-078-05.75-X-D-RF1	QMSS-26-05.75-D-03-RF1	3.105[78.87]	2.833[71.96]
QMS-078-05.75-X-D-RF2	QMSS-26-05.75-D-03-RF2	3.605[91.57]	3.333[84.66]

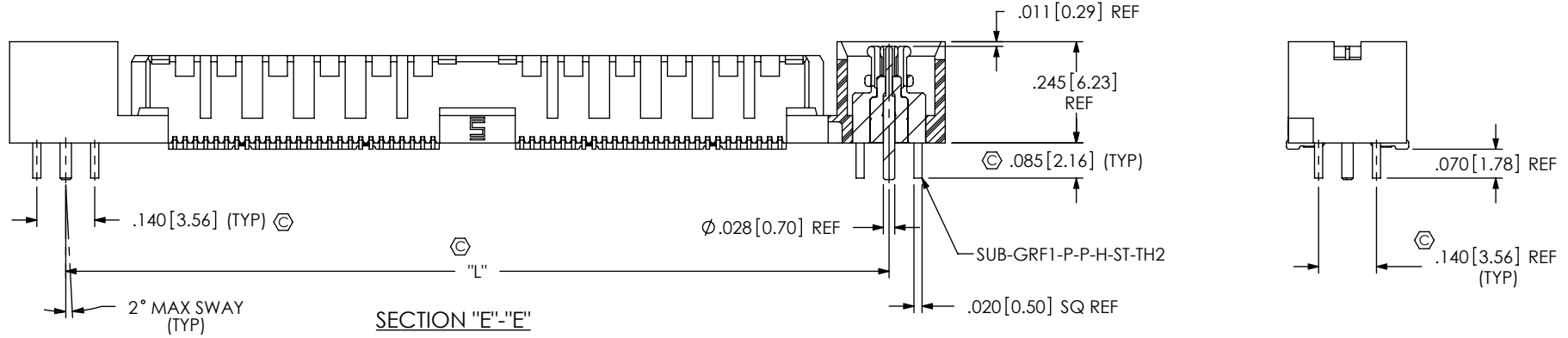
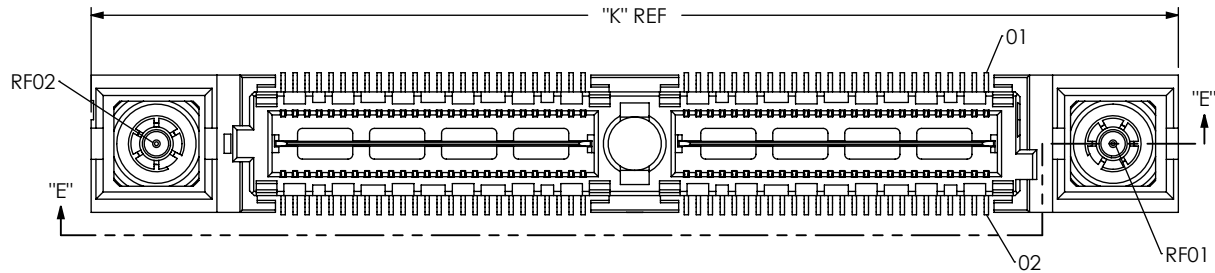

FIG 6
 -RF1 OPTION
 QMS-052-05.75-X-D-RF1 SHOWN
 (SAME AS FIG 1, UNLESS OTHERWISE STATED)
 [NOT AVAILABLE WITH -A OR -GP OPTION, AVAILABLE ON LEAD STYLE -05.75 ONLY]
 (AVAILABLE ON -026, -052 & -078 POSITIONS ONLY)

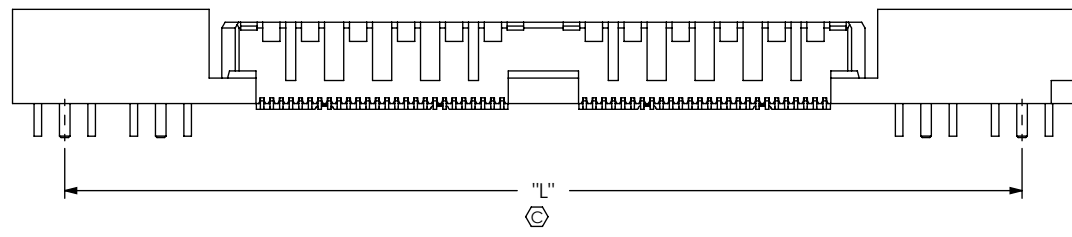
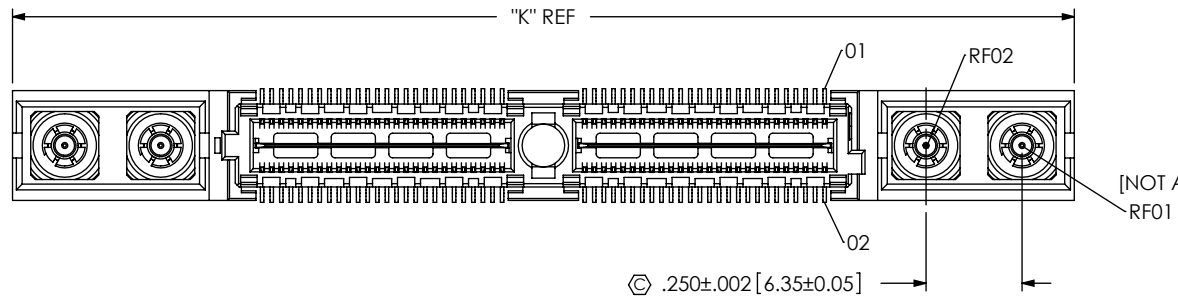

FIG 7
 -RF2 OPTION
 QMS-052-05.75-X-D-RF2 SHOWN
 (SAME AS FIG 6, UNLESS OTHERWISE STATED)
 [NOT AVAILABLE WITH -A OR -GP OPTION, AVAILABLE ON LEAD STYLE -05.75 ONLY]
 (AVAILABLE ON -026, -052 & -078 POSITIONS ONLY)

PROPRIETARY NOTE
 THIS DOCUMENT CONTAINS INFORMATION CONFIDENTIAL AND PROPRIETARY TO SAMTEC, INC. AND SHALL NOT BE REPRODUCED OR TRANSFERRED TO OTHER DOCUMENTS OR DISCLOSED TO OTHERS OR USED FOR ANY PURPOSE OTHER THAN THAT WHICH IT WAS OBTAINED WITHOUT THE EXPRESSED WRITTEN CONSENT OF SAMTEC, INC.

DO NOT SCALE DRAWING

SHEET SCALE: 1:0.4

samtec

520 PARK EAST BLVD, NEW ALBANY, IN 47150
 PHONE: 812-944-6733 FAX: 812-948-5047
 e-Mail: info@SAMTEC.com code: 55322

DESCRIPTION:
 .635mm DOUBLE ROW TERMINAL STRIP

DWG. NO.
 QMS-XXX-XX.XX-XX-D-XX-XXX-XX

BY: E.L.S. 10-12-2010 SHEET 5 OF 6

TABLE 8			
ASSEMBLY	QMS-26-05.75-D-XX-A-RTX	"M"	"N"
QMS-026-05.75-X-D-A-RT1	QMS-26-05.75-D-01-A-RT1	1.425[36.20]	1.153[29.29]
QMS-052-05.75-X-D-A-RT1	QMS-26-05.75-D-02-A-RT1	2.265[57.53]	1.993[50.62]
QMS-078-05.75-X-D-A-RT1	QMS-26-05.75-D-03-A-RT1	3.105[78.87]	2.833[71.96]
QMS-104-05.75-X-D-A-RT1	QMS-26-05.75-D-04-A-RT1	3.945[100.20]	3.673[93.29]

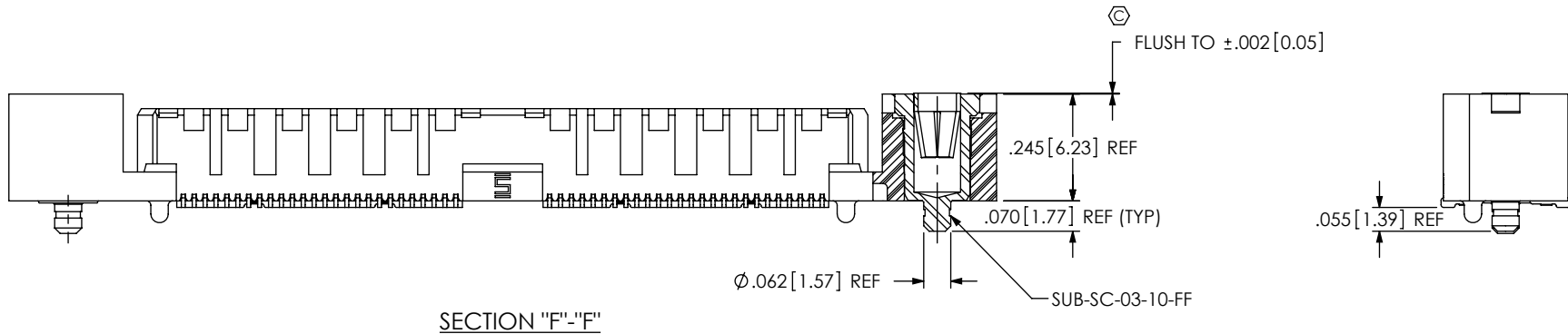
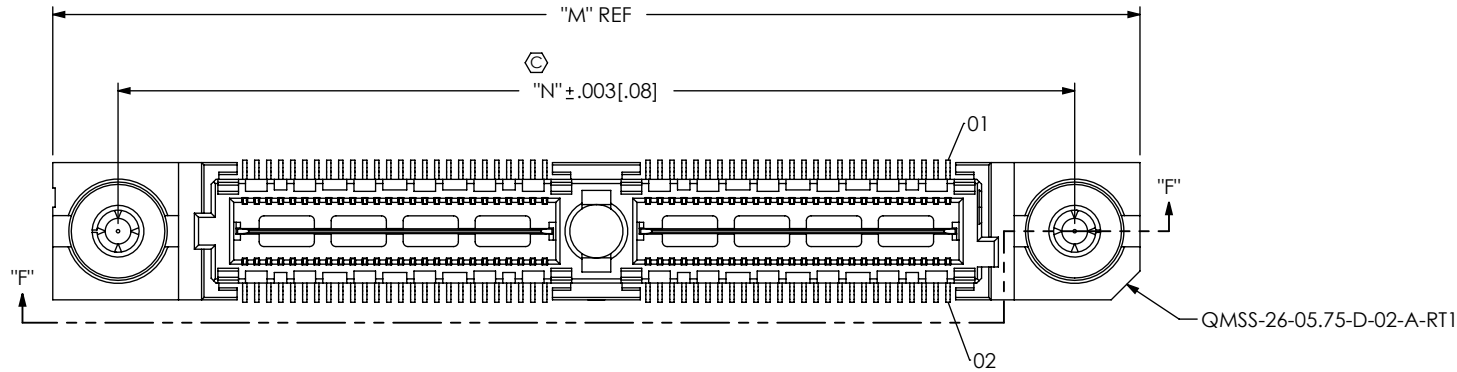

FIG 8

-RT1 OPTION

QMS-052-05.75-X-D-A-RT1 SHOWN

(SAME AS FIG 1, UNLESS OTHERWISE STATED)

[NOT AVAILABLE WITH -GP, -PCX OR -RFX OPTION, AVAILABLE ON LEAD STYLE -05.75 ONLY]

(AVAILABLE ON -026, -052, -078, & -104 POSITIONS WITH -A OPTION ONLY)

PROPRIETARY NOTE

THIS DOCUMENT CONTAINS INFORMATION CONFIDENTIAL AND PROPRIETARY TO SAMTEC, INC. AND SHALL NOT BE REPRODUCED OR TRANSFERRED TO OTHER DOCUMENTS OR DISCLOSED TO OTHERS OR USED FOR ANY PURPOSE OTHER THAN THAT WHICH IT WAS OBTAINED WITHOUT THE EXPRESSED WRITTEN CONSENT OF SAMTEC, INC.

DO NOT SCALE DRAWING

SHEET SCALE: 1:0.4



520 PARK EAST BLVD, NEW ALBANY, IN 47150
 PHONE: 812-944-6733 FAX: 812-948-5047
 e-Mail: info@SAMTEC.com code: 55322

DESCRIPTION:
 .635mm DOUBLE ROW TERMINAL STRIP

DWG. NO.
 QMS-XXX-XX.XX-XX-D-XX-XXX-XX

BY: E.L.S. 10-12-2010 SHEET 6 OF 6