

REVISIONS			
REV	DESCRIPTION, ECN, EAR NO.	DATE	APP'D
A	RELEASE	OCT19/07	A.G.
B	CHANGE DIMS	JUN30/08	K.L.
C	REV PER EAR 14211	JUL10/13	K.L.

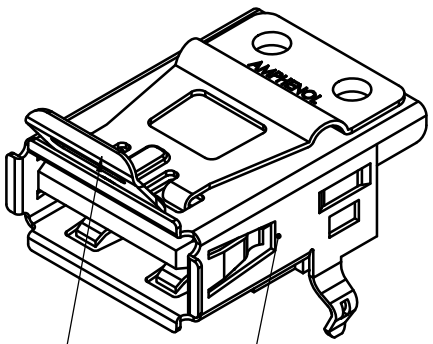

LOCKING TAB
TYPE A- USB RECEPTACLE

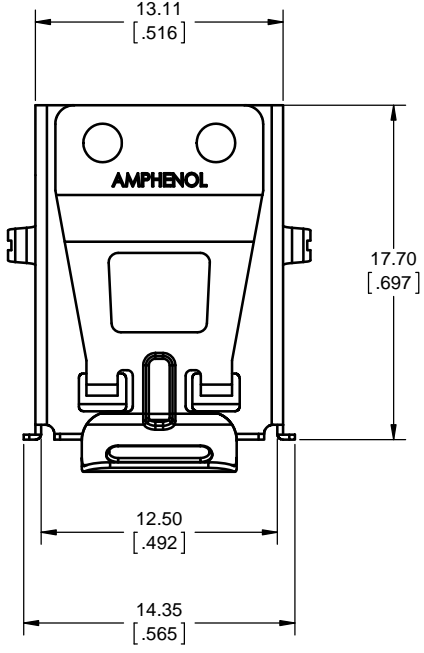
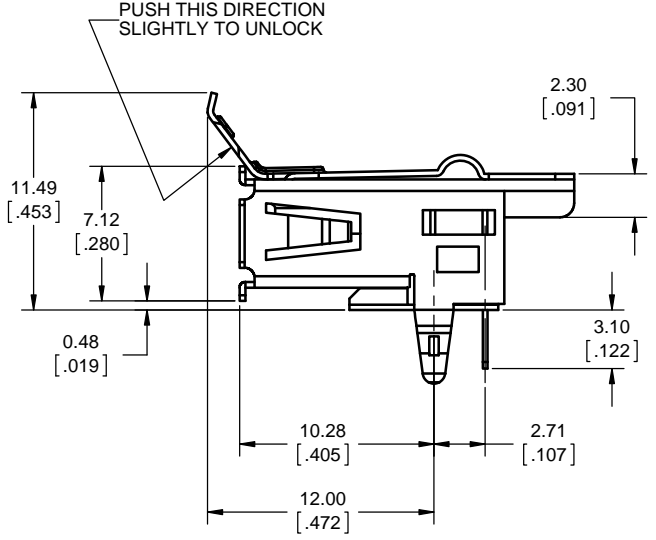
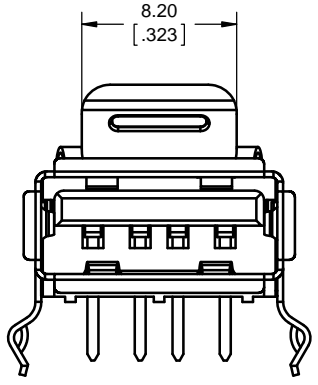

NOTES:

- MATERIAL:
 - SHELL: NICKEL PLATED COPPER ALLOY
 - HOUSING: HIGH TEMPERATURE THERMOPLASTIC UL94V-0, COLOR - BLACK.
 - CONTACTS: PHOSPHOR BRONZE, PLATING: 0.76 MICRONS [30 MICRO] GOLD, OVER NICKEL ON MATING AREA, TIN PLATING ON SOLDER TAILS.
 - LOCKING TAB: STAINLESS STEEL
- FEATURE: POSITIVE LOCK ON TYPE A, USB RIGHT ANGLE RECEPTACLE.
- LOCKING FORCE: MIN. 50 N.
- OPERATING TEMPERATURE: -40°C TO +85°C.
- ALL MATERIALS USED FOR CONNECTOR AND PACKAGING ARE RoHS COMPLIANT PER EU DIRECTIVE 2011/65/EU AND AMENDMENTS.

AMPHENOL PART NUMBER: LUSB-A111-00

UNLESS SPECIFIED OTHERWISE	DRAWN LAWRENCE KIM	OCT19/07
PRIMARY UNITS MILLIMETERS	CHECKED LAWRENCE KIM	OCT19/07
SECONDARY INCHES	M.E. APP'D	
REFERENCE IN PARENTHESES	Q.A. APP'D	
GENERAL TOLERANCES	DWG APPR.	
1 DECIMAL PLACE	ENG. REL. NO.	EAR 14211
2 DECIMAL PLACES ±0.25	REF.	
3 DECIMAL PLACES	THIRD ANGLE PROJECTION	
ANGULAR DEGREES	DO NOT SCALE DRAWING	

Amphenol Canada Corp.
www.amphenolcanada.com
USB A TYPE RECEPTACLE WITH POSITIVE LOCKING TAB RIGHT ANGLE PCB TAIL, RoHS COMPLIANT

DWG. NO. **P-LUSB-A111-00** REV **C**

CODE ID NO. 03554 DWG SIZE: X SCALE: 4:1 SHEET 1 OF 2

REVISIONS			
REV	DESCRIPTION, ECN, EAR NO.	DATE	APP'D
A	RELEASE	OCT19/07	A.G.
B	CHANGE DIMS	JUN30/08	K.L.
C	REV PER EAR 14211	JUL10/13	K.L.

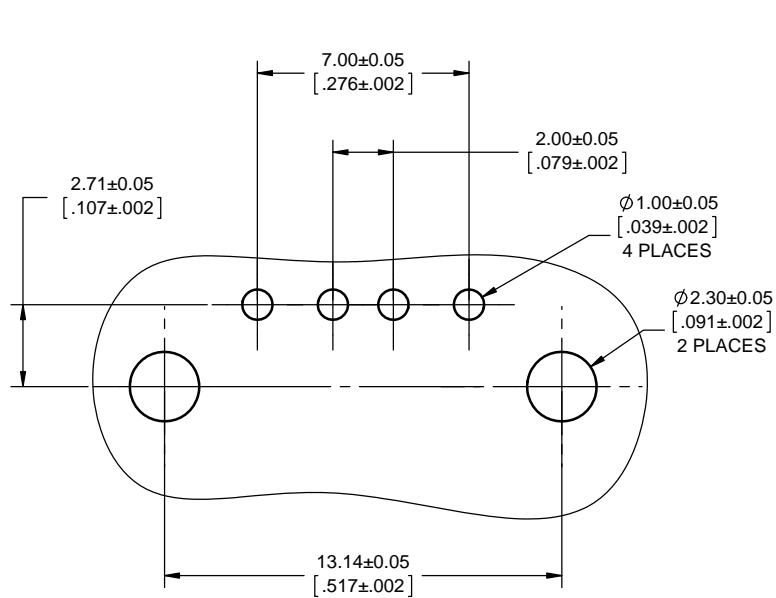

RECOMMENDED PCB LAYOUT

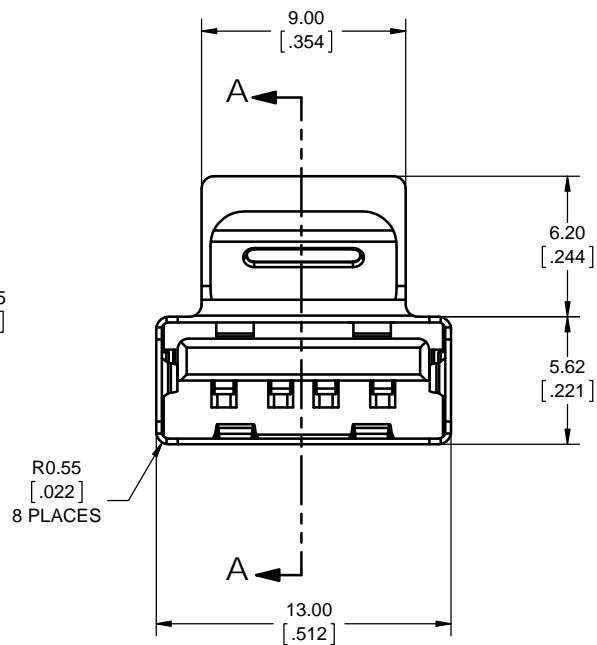

RECOMMENDED PANEL CUT-OUT

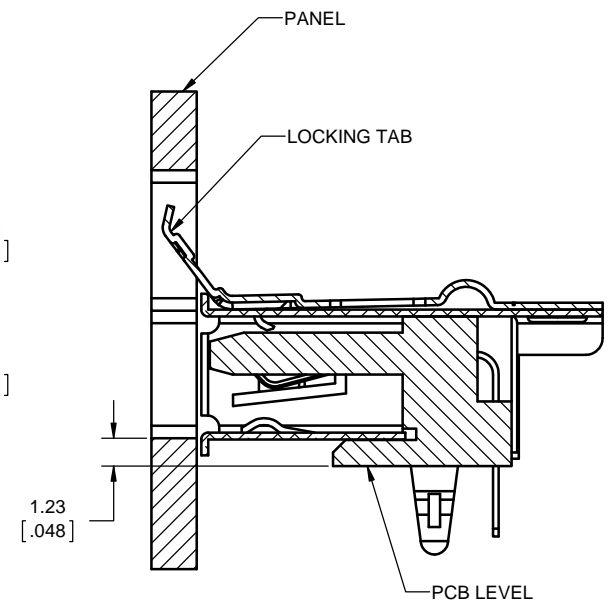

UNLESS SPECIFIED OTHERWISE	DRAWN LAWRENCE KIM	OCT19/07
PRIMARY UNITS MILLIMETERS	CHECKED LAWRENCE KIM	OCT19/07
SECONDARY INCHES	M.E. APP'D	
REFERENCE IN PARENTHESES	Q.A. APP'D	
GENERAL TOLERANCES	DWG APPR.	
1 DECIMAL PLACE	ENG. REL. NO.	EAR 14211
2 DECIMAL PLACES ±0.25	REF.	
3 DECIMAL PLACES	THIRD ANGLE PROJECTION	
ANGULAR DEGREES	DO NOT SCALE DRAWING	

Amphenol Canada Corp.
www.amphenolcanada.com
USB A TYPE RECEPTACLE WITH POSITIVE LOCKING TAB, RIGHT ANGLE PCB TAIL, RoHS COMPLIANT

DWG. NO. **P-USB-A111-00** REV **C**

CODE ID NO. 03554 DWG SIZE: X SCALE: 5:1 SHEET 2 OF 2