

THIS DRAWING IS UNPUBLISHED. RELEASED FOR PUBLICATION 20
 © COPYRIGHT - BY - ALL RIGHTS RESERVED.

REVISIONS					
P	LTR	DESCRIPTION	DATE	DWN	APVD
	Z1	REVISED PER ECO-11-005150	21MAR2011	RK	HMR
	Z2	NEW DRAWING CREATED IN CREO	26JUNE2014	JBH	BRUN

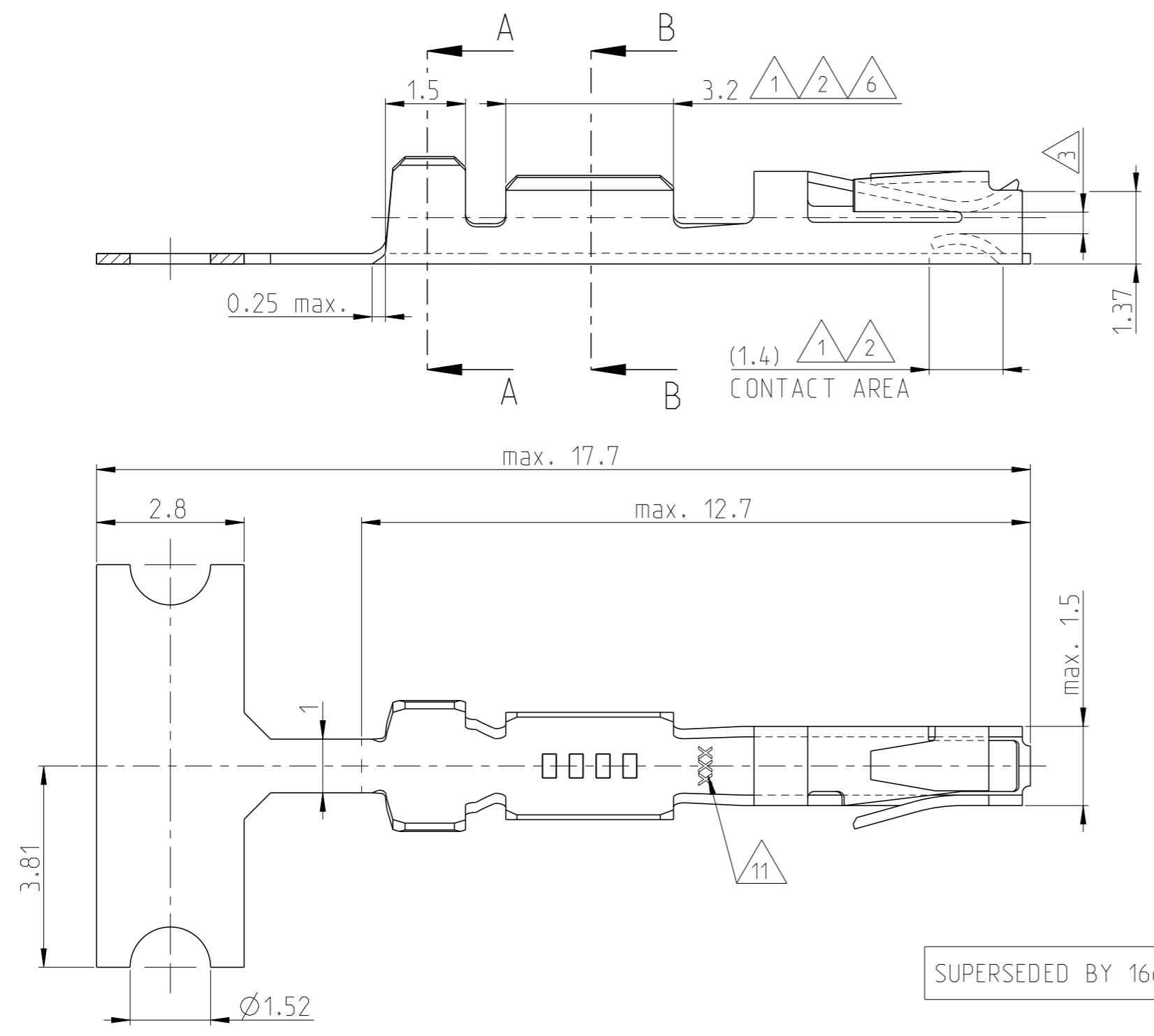

- NOTES:
- 1 UNDERCOATING: 0.8 μm NICKEL OVERALL.
CONTACT AREA: 0.8 μm GOLD.
CRIMP AREA: GOLDFLASH
 - 2 UNDERCOATING: 0.8 μm NICKEL OVERALL.
CONTACT AREA: 1.25 μm GOLD.
CRIMP AREA: GOLDFLASH
 - 3 SUITABLE FOR 0.64x0.64 POST.
 - 6 UNDERCOATING: 0.8 μm NICKEL OVERALL.
CONTACT AREA: 0.4 μm GOLD.
CRIMP AREA: GOLDFLASH.
 - 7 ADVANCED PROD. NRS. FOR DIN 41612 PART 5 SPEC.
 - 8 PLATING: 2.0 μm TIN OVERALL.
 - 9 REVERSE REELED FOR USE WITH MINI APPLICATOR.
 - 10 STANDARD REELED FOR USE WITH STANDARD APPLICATOR.
 - 11 TRADE MARK.

WIRE RANGE:
20-24 (26) AWG
INSULATION RANGE:
1.40 MAX DIA.

SUPERSEDED BY 166500-2

166722-1	1	PHOSPHORBRONZE	1-166500-2	10	Z
166722-6	8		1-166500-1	10	Z
166722-6	8		166500-9	9	Z
166722-4	6		166500-7	9	W
166722-2	2		166500-4	9	Z
166722-1	1		166500-2	9	Z
LOOSE PIECE NUMBER	PLATING		MATERIAL	STRIPNUMBER	REV

SECTION A-A

SECTION B-B

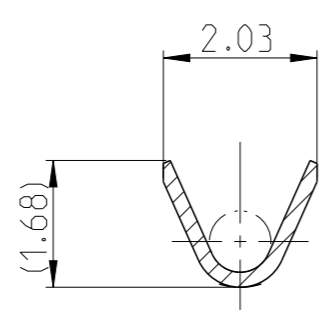
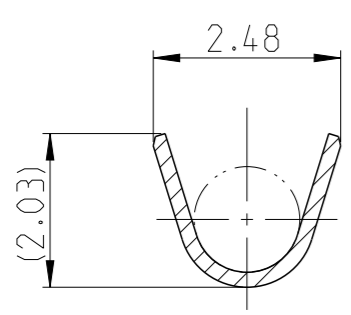

THIS DRAWING IS A CONTROLLED DOCUMENT.

DIMENSIONS:	TOLERANCES UNLESS OTHERWISE SPECIFIED:
mm	n. ISO 8015 n. ISO 2768-mH
	0 PLC ±
	1 PLC ±
	2 PLC ±
	3 PLC ±
	4 PLC ±
	ANGLES ±1°
MATERIAL	FINISH
-	-

DWN	M.Pfeilschiffer	18JUL2000
CHK	V.Huhn	18JUL2000
APVD	-	-
PRODUCT SPEC	-	-
APPLICATION SPEC	-	-
WEIGHT	-	-

STE TE Connectivity

NAME: STANDARD TANDEM SPRING RECEPTACLE

SIZE	CAGE CODE	DRAWING NO	RESTRICTED TO
A3	00779	166500	-

Customer Drawing SCALE 10:1 SHEET 1 OF 1 REV Z2