

10091767 - X 0 C - X X X L F

6-COLUMN DIFFERENTIAL SIGNAL

LEAD-FREE DESIGNATION ONLY WITH APPLICABLE PLATING CODES

LETTER	PERFORMANCE-BASED PLATING (SEE NOTE 2)	
	TARGET APPLICATION	LEAD FREE (LF)
B	TELCORDIA CO	NO
C	TELCORDIA UE	NO
D	TELCORDIA CO	YES
E	TELCORDIA UE	YES

NUMBER	PIN STYLE, HEIGHT
0	STANDARD GUIDE PIN MACHINED, 31.6mm
4	STANDARD GUIDE PIN MACHINED, 25.7mm

MODULE DESCRIPTION	LETTER DESIGNATION REPRESENTED IN DASH NUMBER										BASE MODULE
	J	A	B	C	D	E	F	G	H		
LEFT POLARIZING GUIDANCE MODULE (SEE SHEET 3)											
RIGHT POLARIZING GUIDANCE MODULE (SEE SHEET 4)											
OPEN MODULE (TWO WALL) (SEE SHEET 2)	0 (ZERO)										
LEFT WALL MODULE (SEE SHEET 5)	L										
RIGHT WALL MODULE (SEE SHEET 6)	M										
FOUR WALL MODULE (SEE SHEET 7)	1										

NUMBER	CONTACT MATING WIPE LENGTH		COMPLIANT PIN DRILL SIZE
	SIGNAL	WIDE GROUND	
1	2	4	Ø0.55 [0.0217"]
2	3	4	Ø0.55 [0.0217"]
3	2	4	Ø0.45 [0.0177"]
4	3	4	Ø0.45 [0.0177"]
5	2	3	Ø0.55 [0.0217"]
6	3	3	Ø0.55 [0.0217"]
7	2	3	Ø0.45 [0.0177"]
8	3	3	Ø0.45 [0.0177"]

	GROUNDED	UNGROUNDED
FINISHED	Ø2.35-2.55	Ø2.35-2.55
PAD	Ø5.50	N/A
PLATED	YES	NO
DRILL (mm/in)	2.58 / .1015	2.44 / .096

SCREW P/N	DESCRIPTION	BOARD THICKNESS
10091790-002LF	#2-56 X .375" PHILLIPS PANHEAD W/SQ CONICAL WASHER	1.60 - 5.00
10091790-003LF	#2-56 X .500" PHILLIPS PANHEAD W/SQ CONICAL WASHER	5.00 - 10.00

spec ref	SEE NOTES	dr	Jim Swain	2009/03/02	projection	MM	size	A2	scale	4:1
tolerance std	ASME Y14.5	eng	Roger Ng	2011/07/01	chr	-	ecn no	ELX-S-004099-1	rel level	Released
surface	linear	appr	Chen-Hong Tan	2011/07/04	product family	XCede	sig no	10091767	rev	B
ASME Y14.5	angular	www.fci.com	cat. no.	SEE P/N TREE	Product - Customer Drw	sheet 1 of 8				

Copyright FCI. FCI

OPEN (2-WALL) MODULE

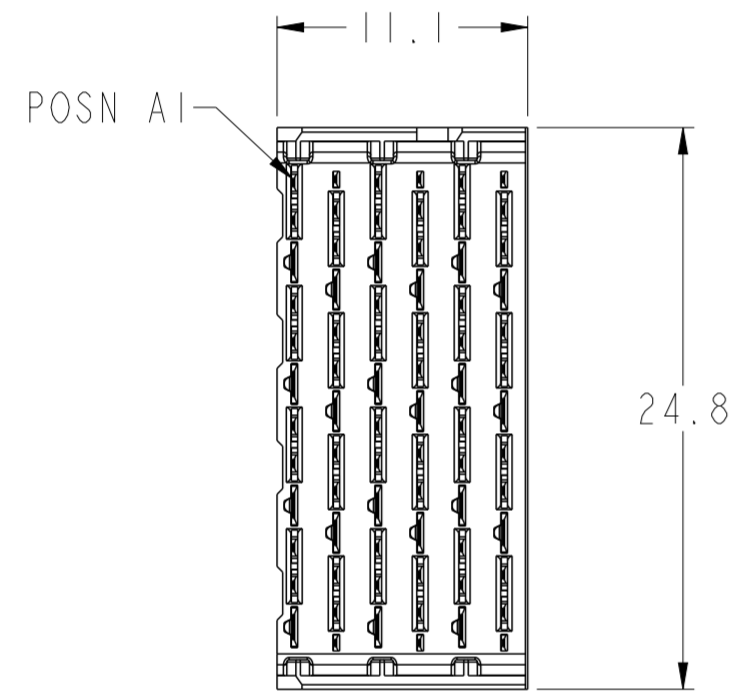
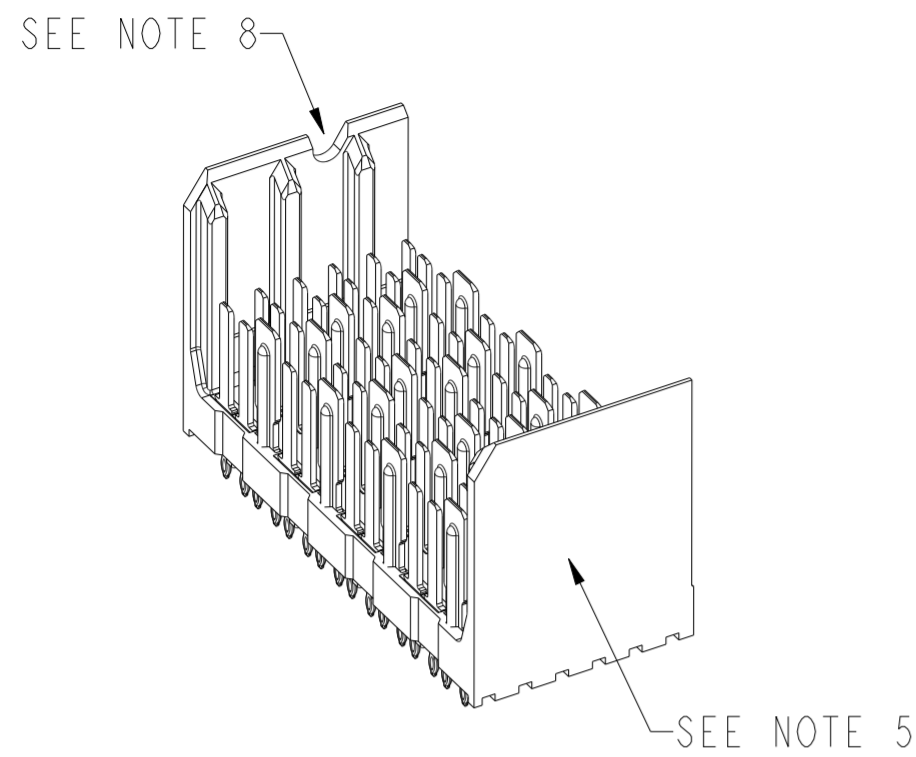

- 6.2 (4MM WIPE WIDE GROUNDS)
- 5.2 (3MM WIPE WIDE GROUNDS)
- 5.2 (3MM SMALL END GROUNDS)
- 5.2 (3MM WIPE SIGNALS)
- 4.2 (2MM WIPE SIGNALS)
- SEE P/N TREE

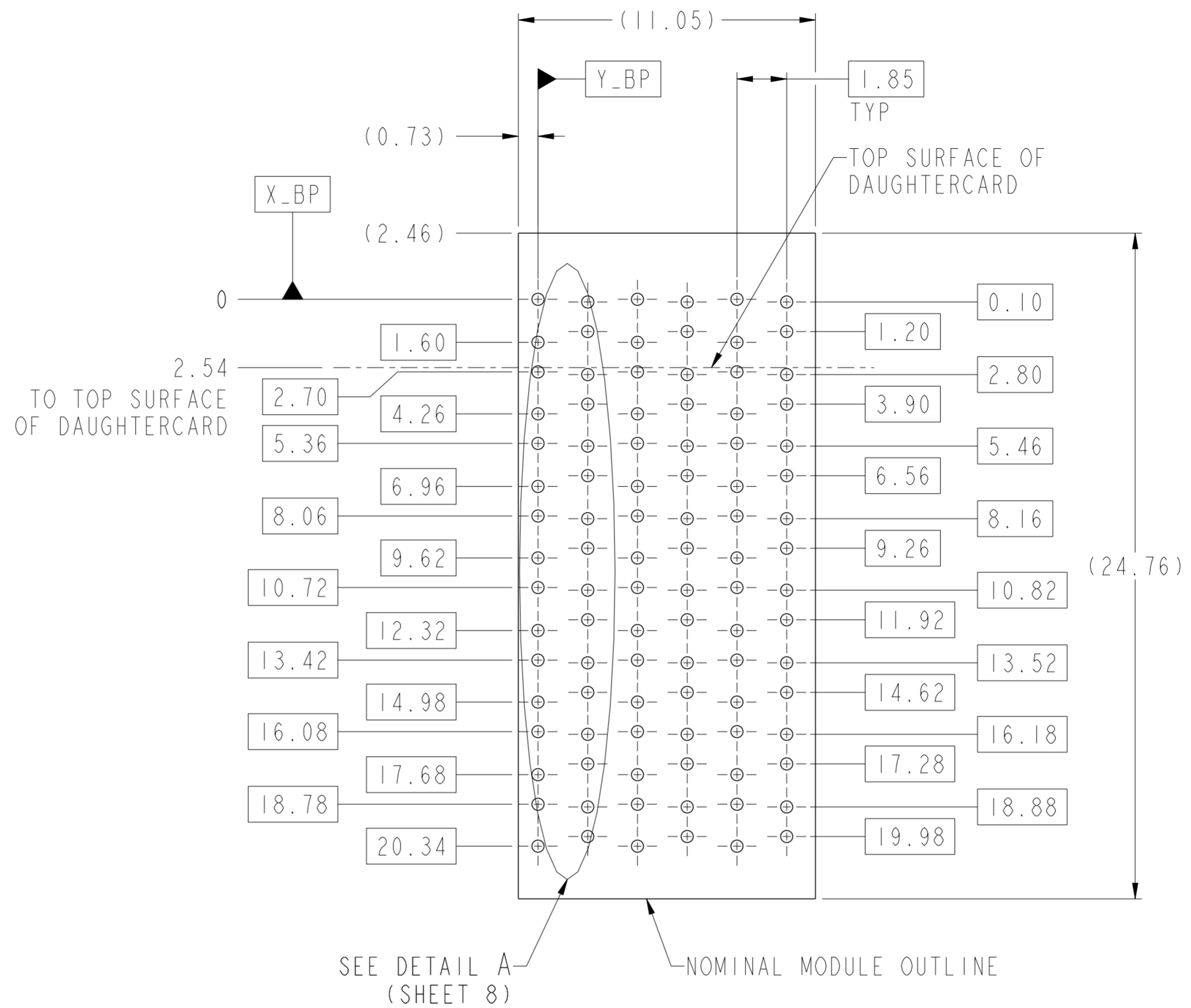
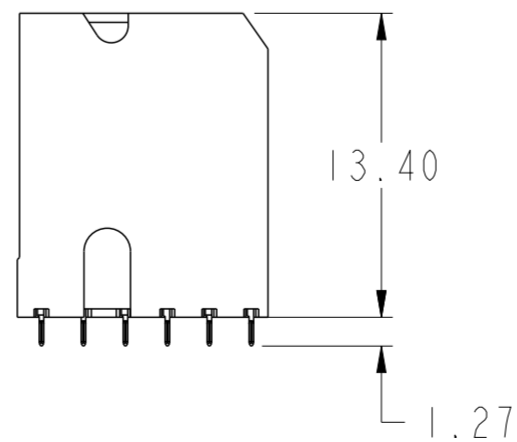
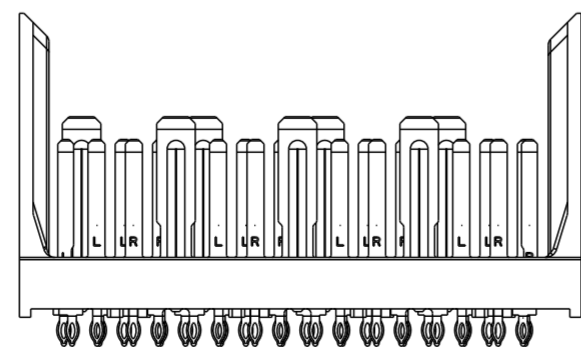
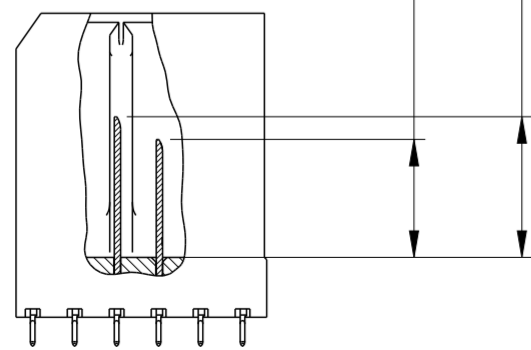

spec ref	SEE NOTES	dr	Jim Swain	2009/03/02	projection	MM	size	A2	scale	4:1	
tolerance std	ASME Y14.5	eng	Roger Ng	2011/07/01			ecn no	ELX-S-004099-1	rel level	Released	
TOLERANCES UNLESS OTHERWISE SPECIFIED		chr	-	appr							Chen-Hong Tan
surface	✓	linear	0.X	±0.2				TITLE MODULE ASSEMBLY VERTICAL HEADER, 6-COLUMN, 4-PAIR		dwg no 10091767	rev B
			0.XX	±0.10							
		angular	0°	±°	www.fci.com		cat. no. SEE P/N TREE		Product - Customer Drw		sheet 2 of 8

LEFT POLARIZING/GUIDE MODULE

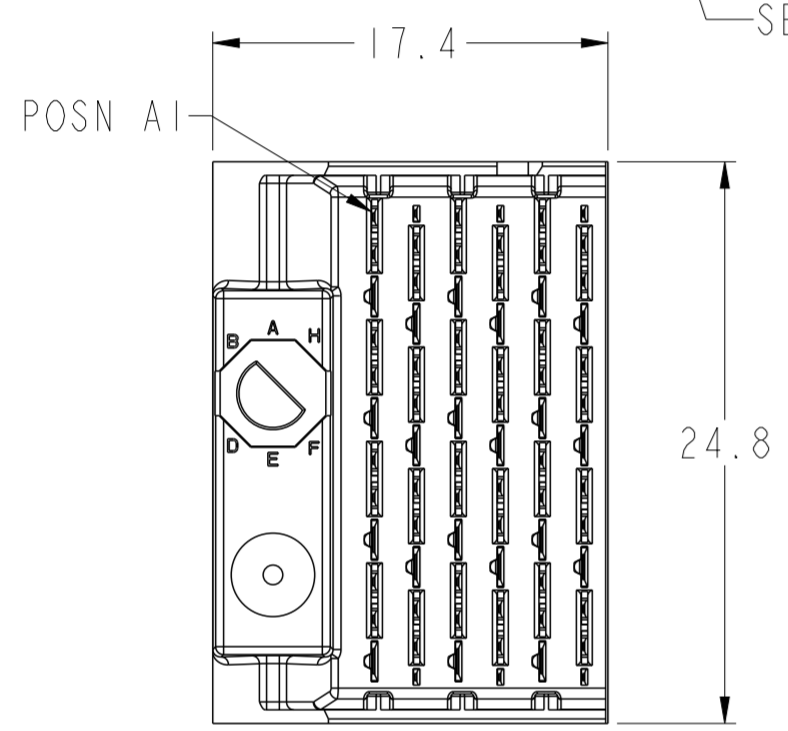
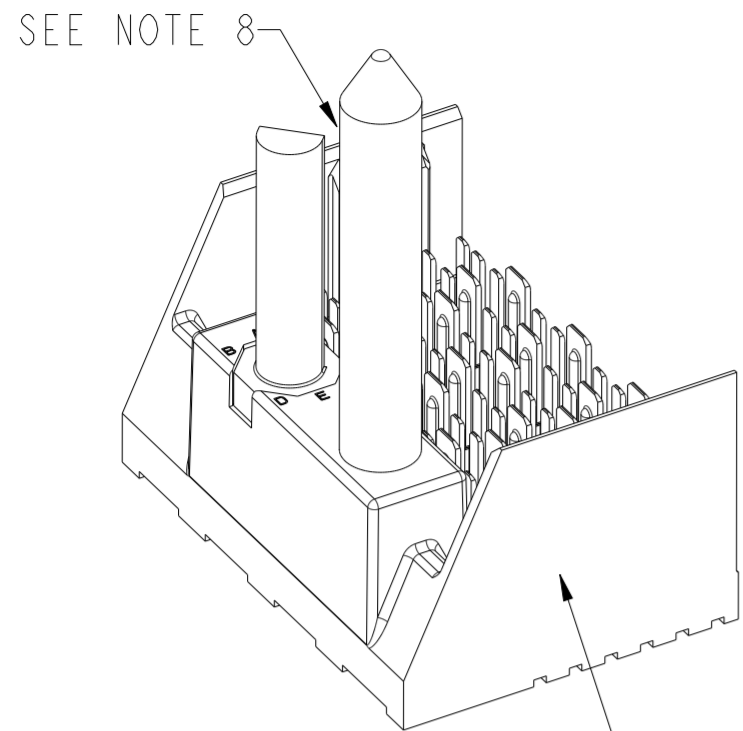

- 6.2 (4MM WIPE WIDE GROUNDS)
 - 5.2 (3MM WIPE WIDE GROUNDS)
 - 5.2 (3MM SMALL END GROUNDS)
 - 5.2 (3MM WIPE SIGNALS)
 - 4.2 (2MM WIPE SIGNALS)
- SEE P/N TREE

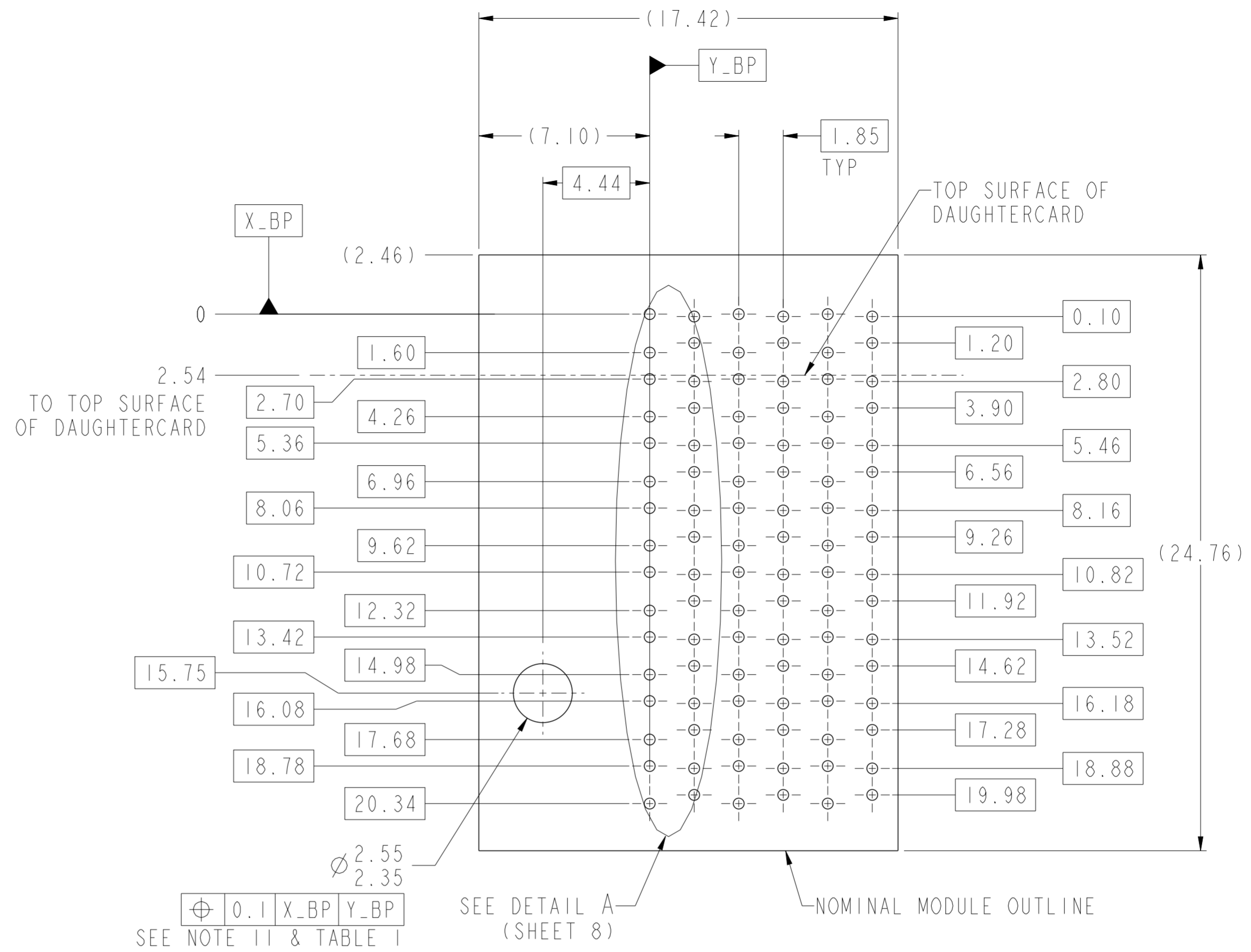
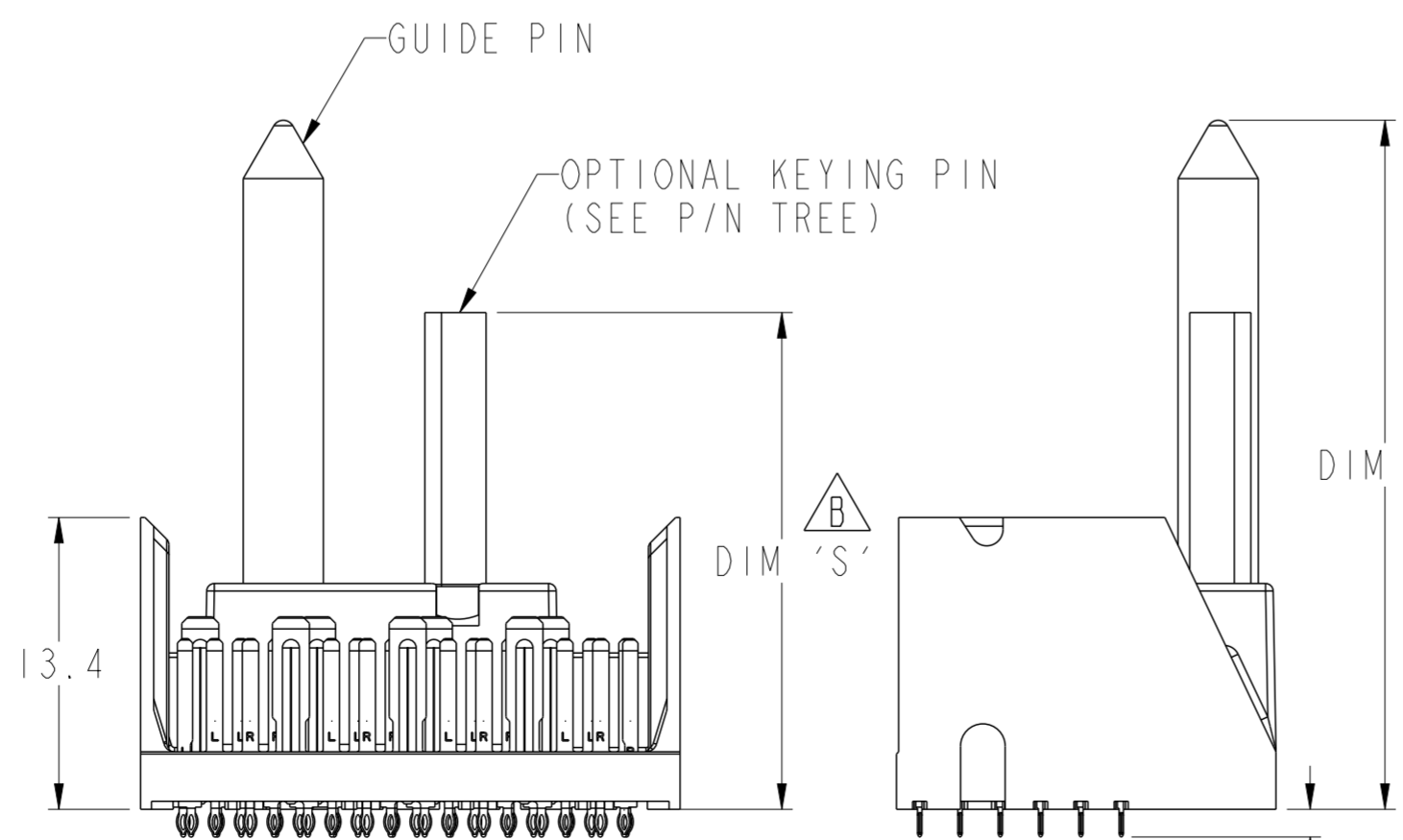
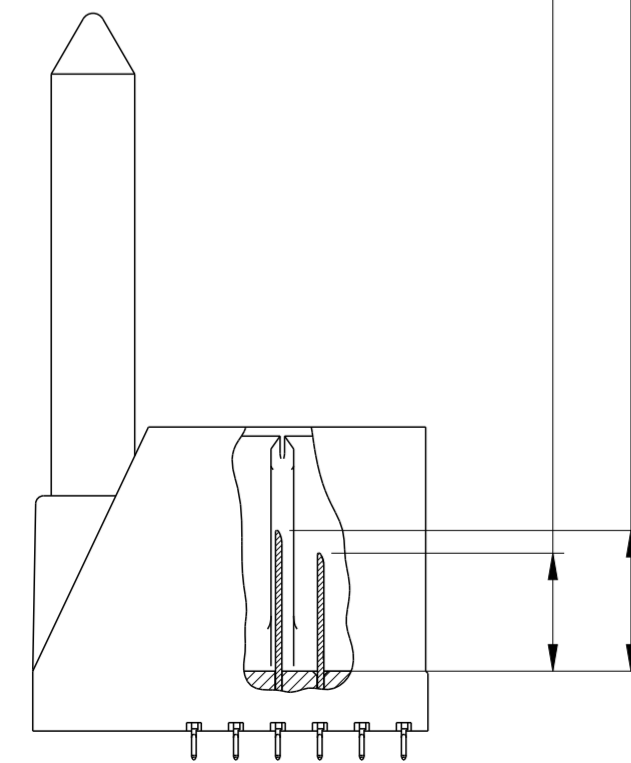

ASSEMBLY BASE CONFIGURATION END DASH NO.	GUIDE PIN	POLARIZING KEY
	DIM 'R'	DIM 'S'
-X0X	31.6mm	22.8mm
-X4X	25.7mm	20.0mm

spec ref	SEE NOTES	dr	Jim Swain	2009/03/02	projection	MM	size	A2	scale	4:1	
tolerance std	ASME Y14.5	eng	Roger Ng	2011/07/01	chr		ecn no	ELX-S-004099-1	rel level	Released	
surface	linear	0.X	±0.2	0.XX	±0.10	0.XXX	±0.050	angular	0°	±°	
www.fci.com		FCI		MODULE ASSEMBLY		VERTICAL HEADER, 6-COLUMN, 4-PAIR		cat. no.	SEE P/N TREE	Product - Customer Drw	sheet 3 of 8

RIGHT POLARIZING/GUIDE MODULE

SEE NOTE 8

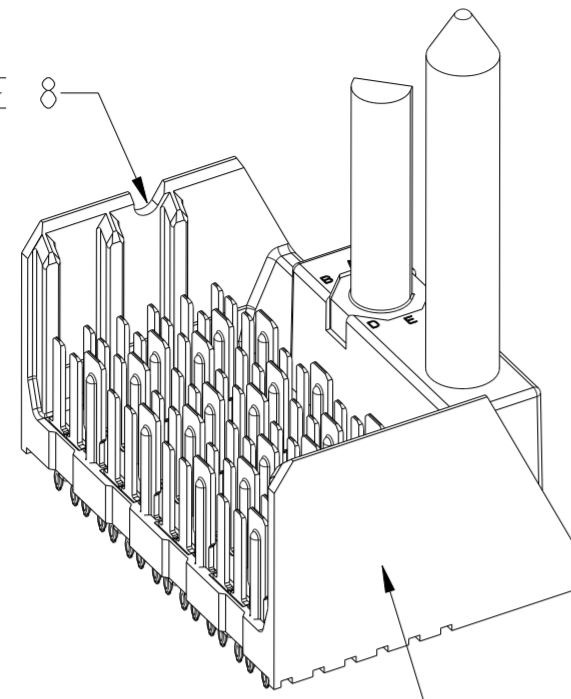

SEE NOTE 5

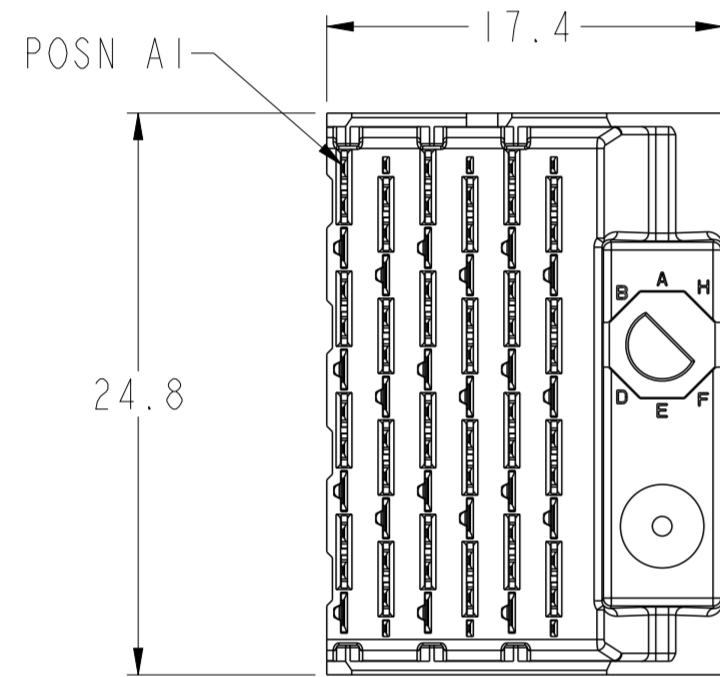

2.54
TO TOP SURFACE
OF DAUGHTERCARD

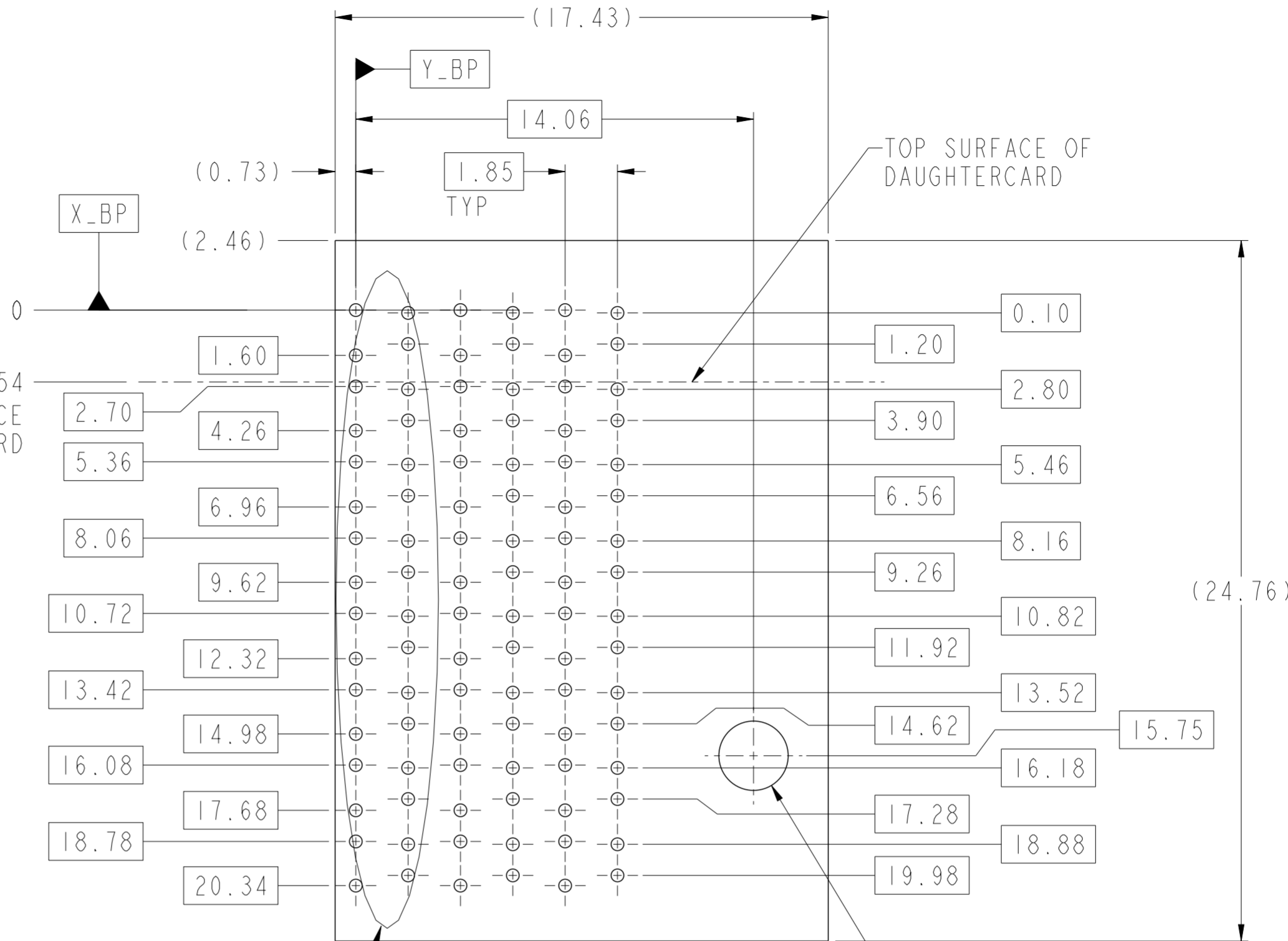

SEE DETAIL A
(SHEET 8)

PCB HOLE PATTERN
COMPONENT SIDE
SCALE 6:1

Ø 2.55
2.35
Ø 0.10 X_BP Y_BP
SEE NOTE 11 & TABLE 1

- 6.2 (4MM WIPE WIDE GROUNDS)
- 5.2 (3MM WIPE WIDE GROUNDS)
- 5.2 (3MM SMALL END GROUNDS)
- 5.2 (3MM WIPE SIGNALS)
- 4.2 (2MM WIPE SIGNALS)
- SEE P/N TREE

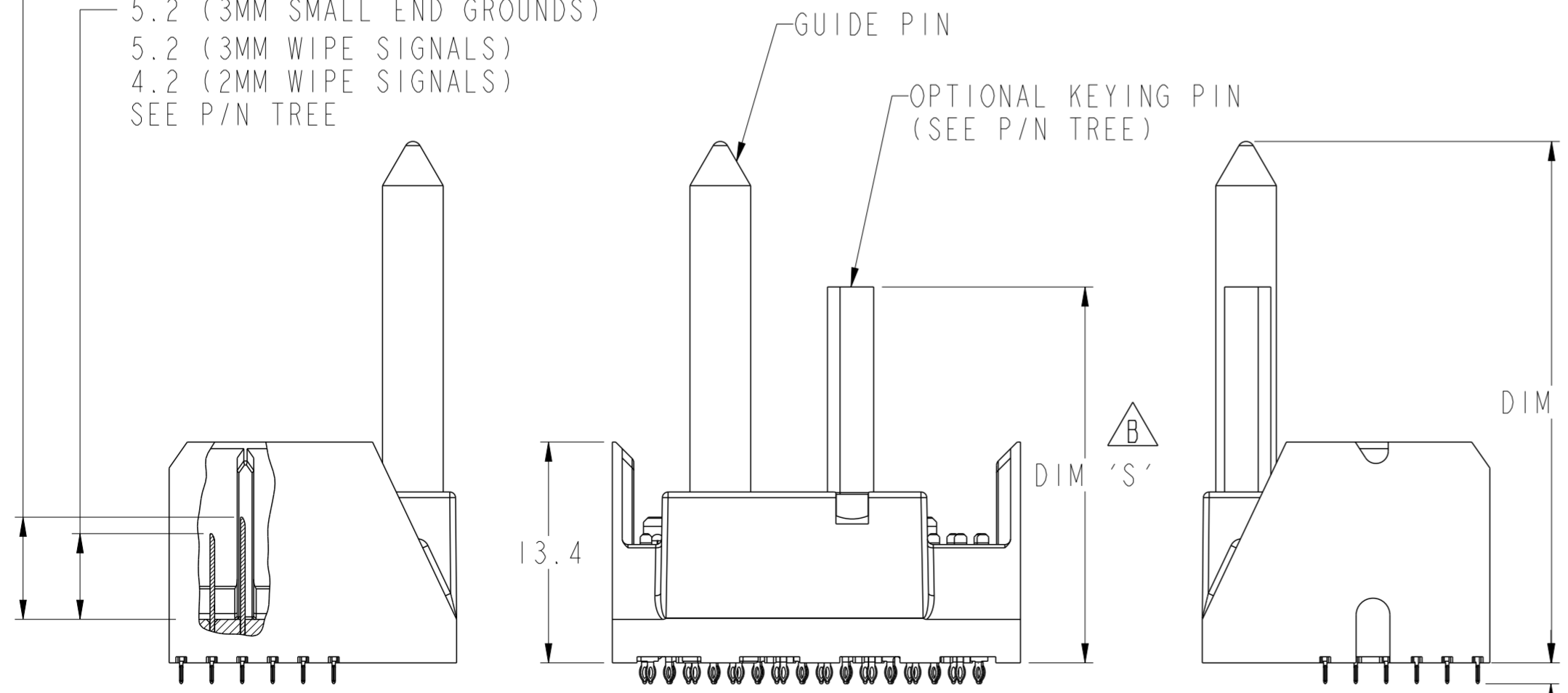

ASSEMBLY BASE CONFIGURATION END DASH NO.	GUIDE PIN	POLARIZING KEY
	DIM 'R'	DIM 'S'
-X0X	31.6mm	22.8mm
-X4X	25.7mm	20.0mm

spec ref	SEE NOTES	dr	Jim Swain	2009/03/02	projection	MM	size	A2	scale	4:1
tolerance std	TOLERANCES UNLESS OTHERWISE SPECIFIED	eng	Roger Ng	2011/07/01	chr		ecn no	ELX-S-004099-1		
ASME Y14.5		app'r	Chen-Hong Tan	2011/07/04	product family	XCede	rel level	Released		
surface	linear	0.X	±0.2		MODULE ASSEMBLY VERTICAL HEADER, 6-COLUMN, 4-PAIR		dwg no	10091767	rev	B
		0.XX	±0.10		cat. no.	SEE P/N TREE	Product - Customer Drw	sheet 4 of 8		
ASME Y14.5	angular	0°	±							

PDS: Rev :B

STATUS:Released

Printed: Jul 04, 2011

Copyright FCI. FCI

LEFT WALL MODULE

SEE NOTE 8

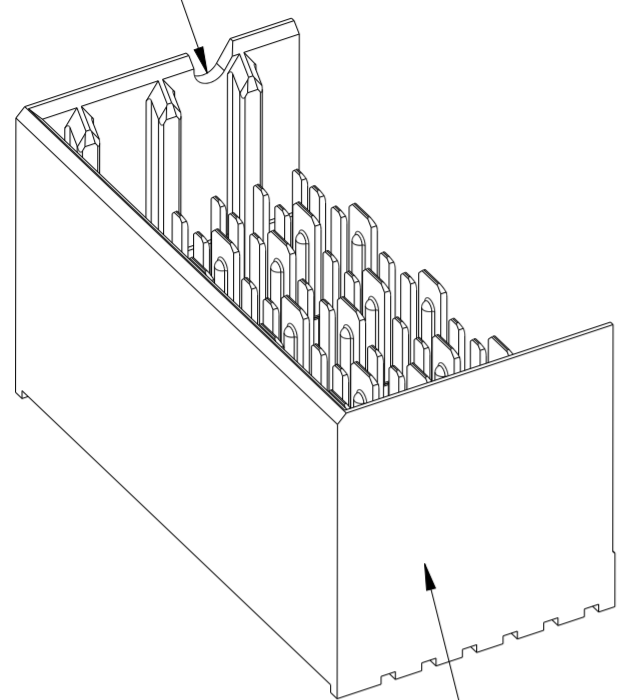

SEE NOTE 5

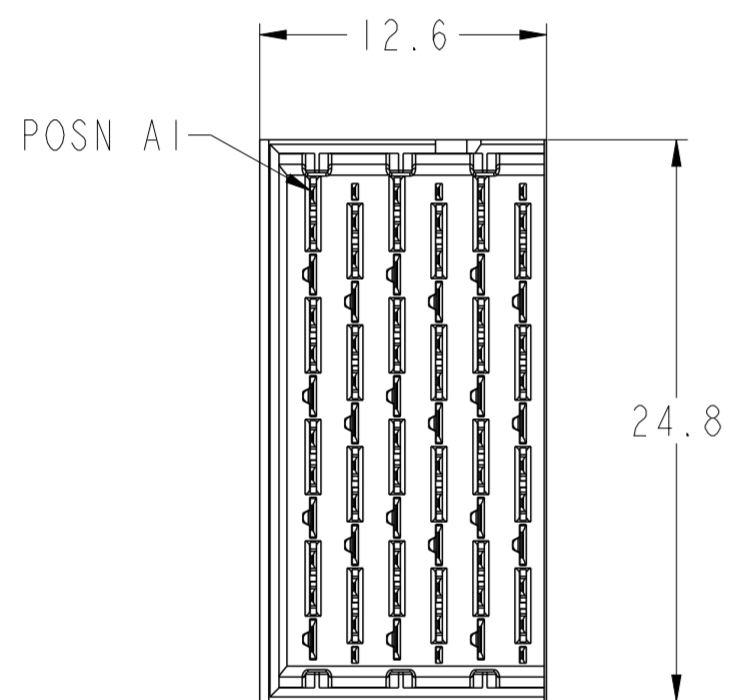

- 6.2 (4MM WIPE WIDE GROUNDS)
- 5.2 (3MM WIPE WIDE GROUNDS)
- 5.2 (3MM SMALL END GROUNDS)
- 5.2 (3MM WIPE SIGNALS)
- 4.2 (2MM WIPE SIGNALS)
- SEE P/N TREE

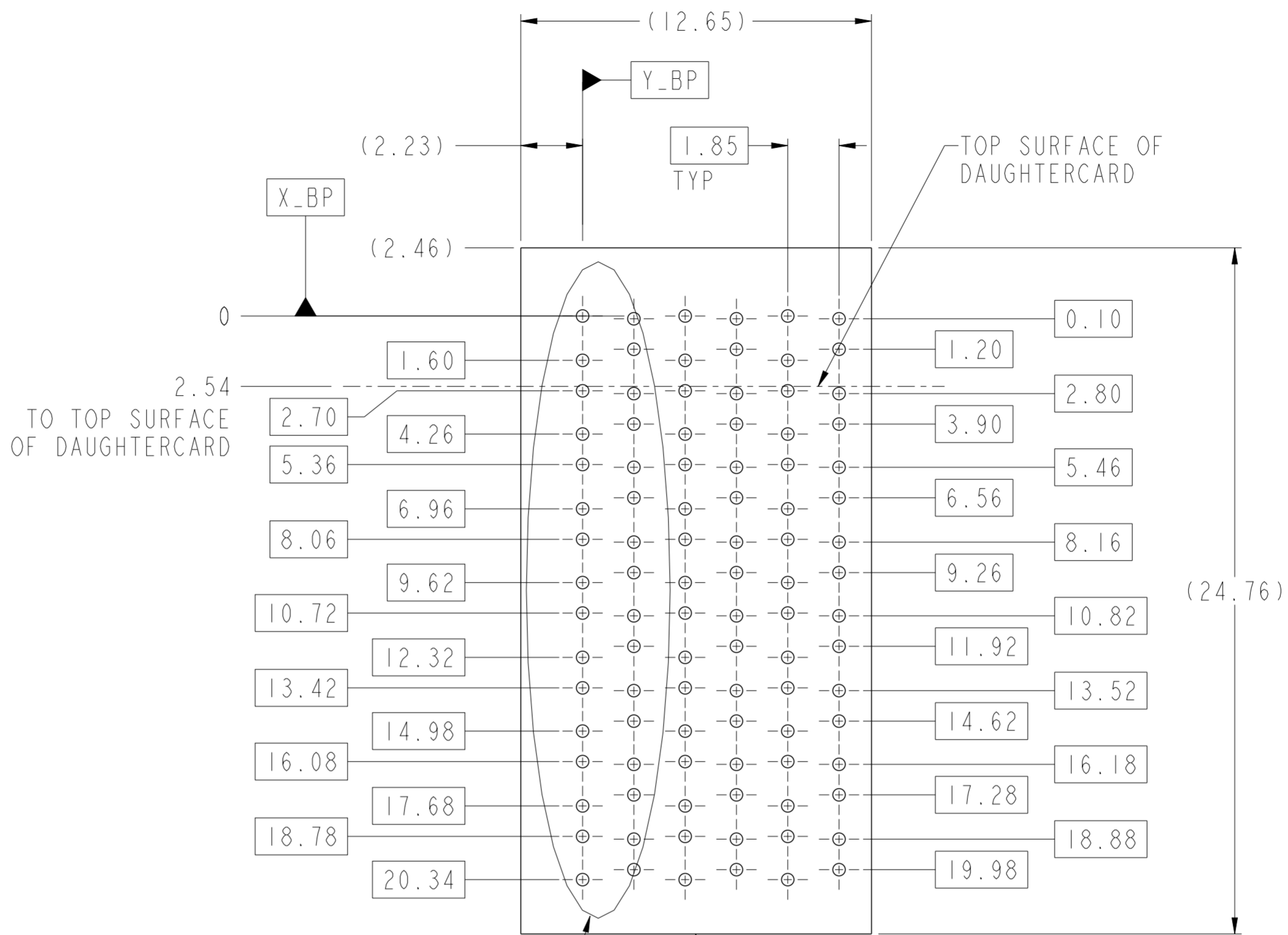
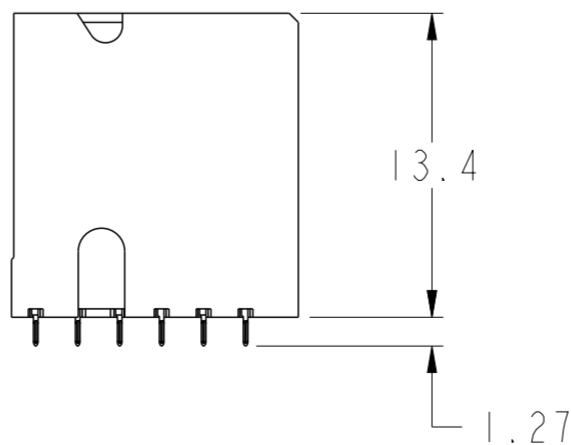
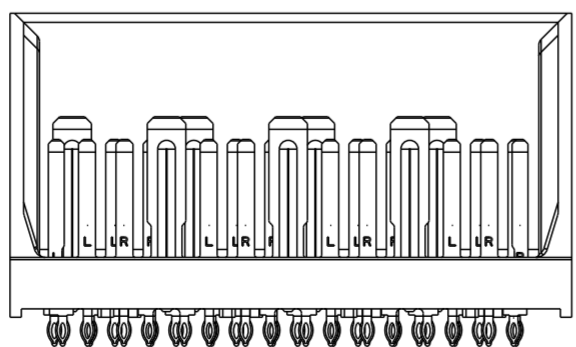
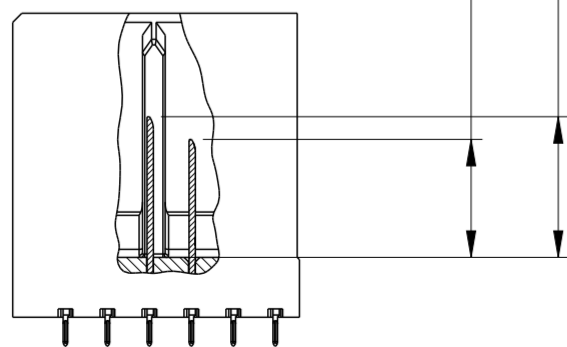

SEE DETAIL A (SHEET 8)

NOMINAL MODULE OUTLINE

PCB HOLE PATTERN
COMPONENT SIDE
SCALE 6:1

spec ref	SEE NOTES	dr	Jim Swain	2009/03/02	projection	MM	size	A2	scale	4:1
tolerance std	ASME Y14.5	eng	Roger Ng	2011/07/01			ecn no	ELX-S-004099-1		
TOLERANCES UNLESS OTHERWISE SPECIFIED		chr	-	appr			Chen-Hong Tan	2011/07/04	product family	XCode
surface	✓	linear	0.X	±0.2			MODULE ASSEMBLY VERTICAL HEADER, 6-COLUMN, 4-PAIR		dwg no	10091767
ASME Y14.5	angular	0°	±	cat. no.					SEE P/N TREE	Product - Customer Drw

RIGHT WALL MODULE

SEE NOTE 8

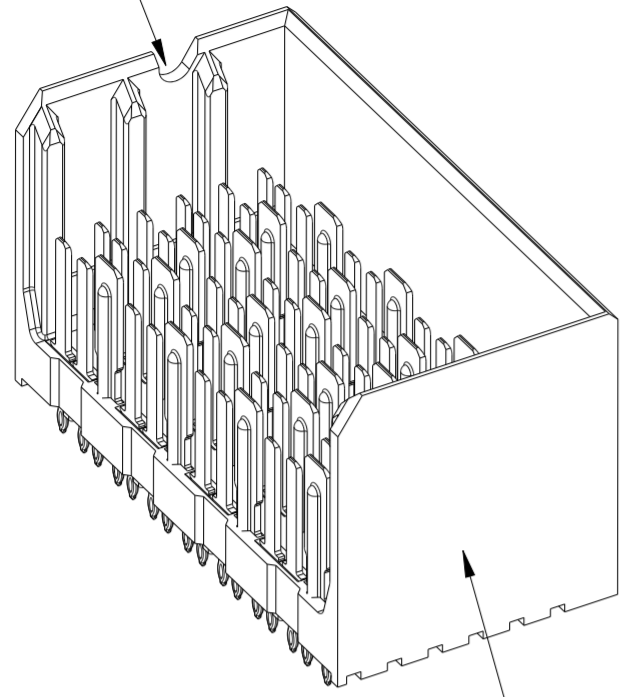

SEE NOTE 5

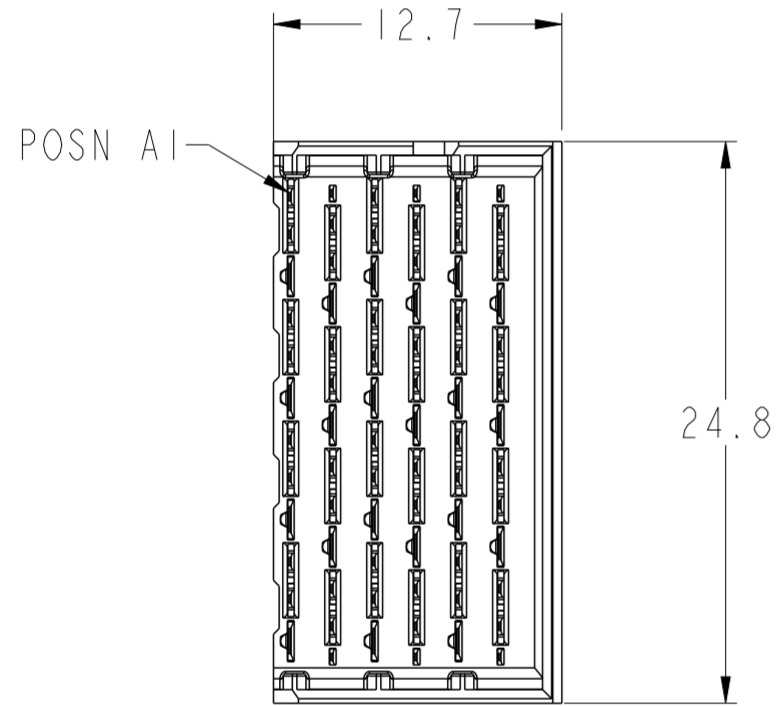

- 6.2 (4MM WIPE WIDE GROUNDS)
- 5.2 (3MM WIPE WIDE GROUNDS)
- 5.2 (3MM SMALL END GROUNDS)
- 5.2 (3MM WIPE SIGNALS)
- 4.2 (2MM WIPE SIGNALS)
- SEE P/N TREE

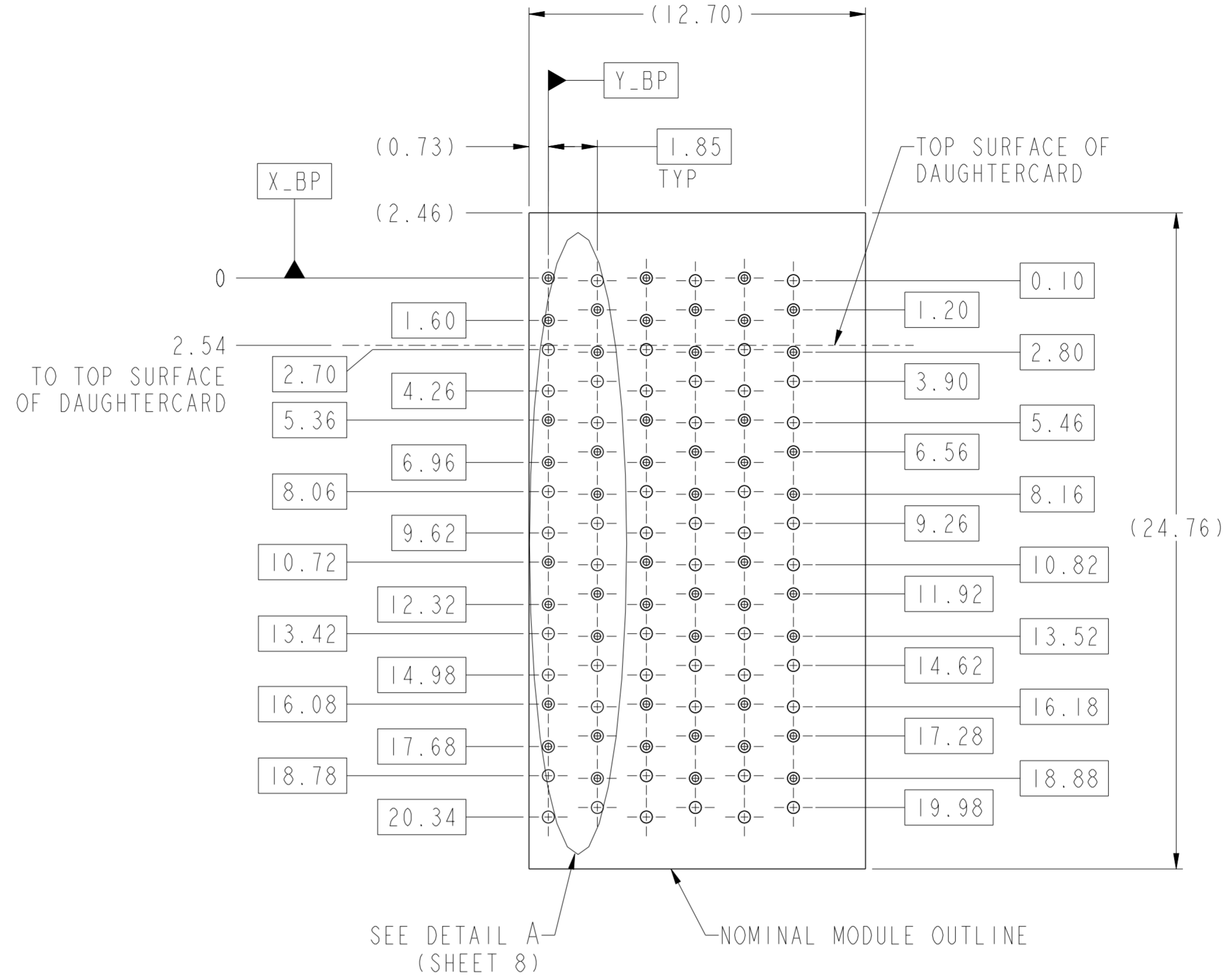
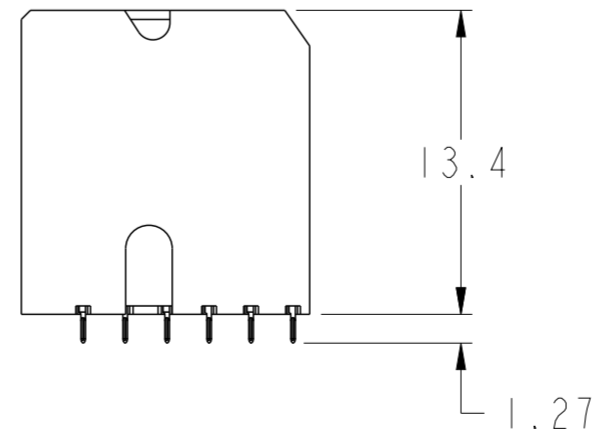
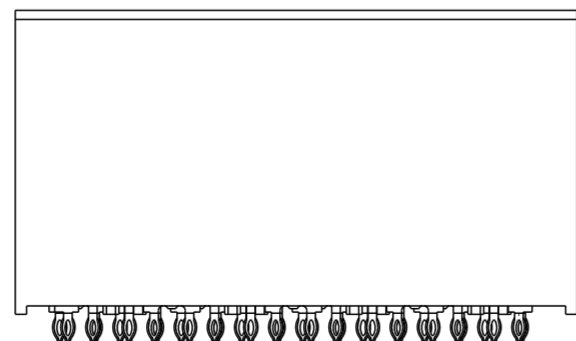
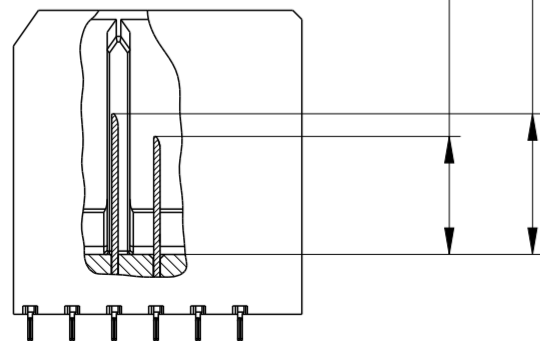

PCB HOLE PATTERN
COMPONENT SIDE
SCALE 6:1

spec ref	SEE NOTES	dr	Jim Swain	2009/03/02	projection	MM	size	A2	scale	4:1
tolerance std	ASME Y14.5	eng	Roger Ng	2011/07/01			ecn no	ELX-S-004099-1		
TOLERANCES UNLESS OTHERWISE SPECIFIED		chr	-	appr			Chen-Hong Tan	2011/07/04	product family	XCode
surface	✓	linear	0.X	±0.2			dwg no	10091767		
		0.XX	±0.10		FCJ		rev	B		
		0.XXX	±0.050		www.fci.com		cat. no.	SEE P/N TREE		
ASME Y14.5	angular	0°	±°		www.fci.com		Product - Customer Drw	sheet 6 of 8		



4-WALL MODULE

SEE NOTE 8

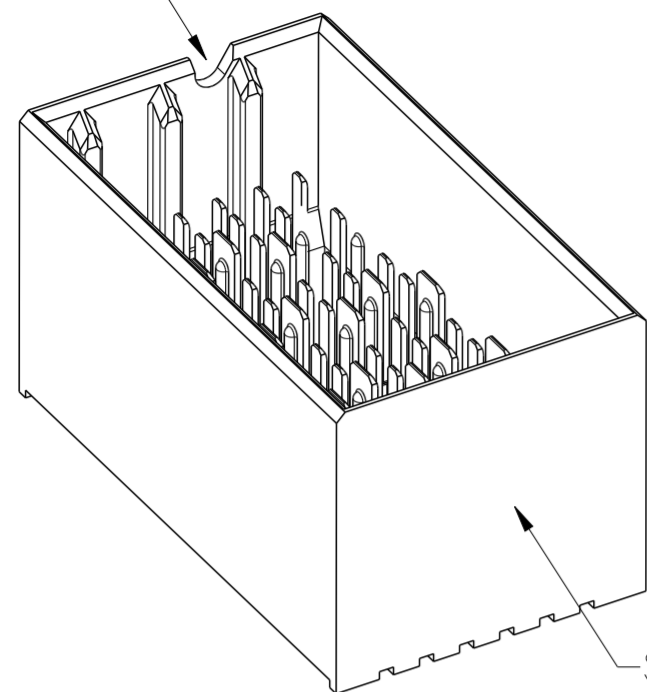

SEE NOTE 5

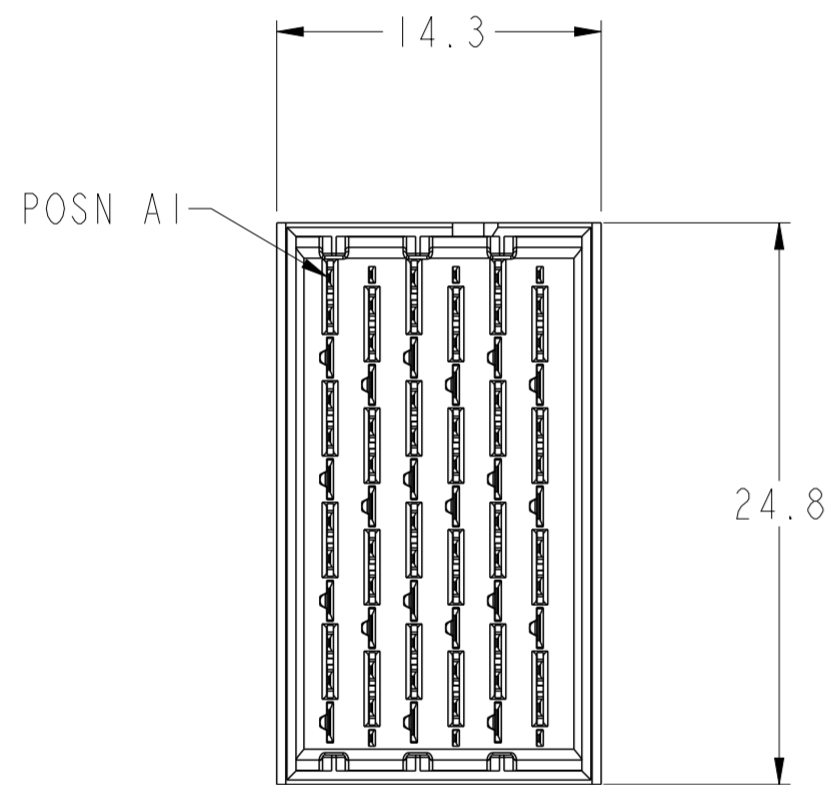

- 6.2 (4MM WIPE WIDE GROUNDS)
- 5.2 (3MM WIPE WIDE GROUNDS)
- 5.2 (3MM SMALL END GROUNDS)
- 5.2 (3MM WIPE SIGNALS)
- 4.2 (2MM WIPE SIGNALS)
- SEE P/N TREE

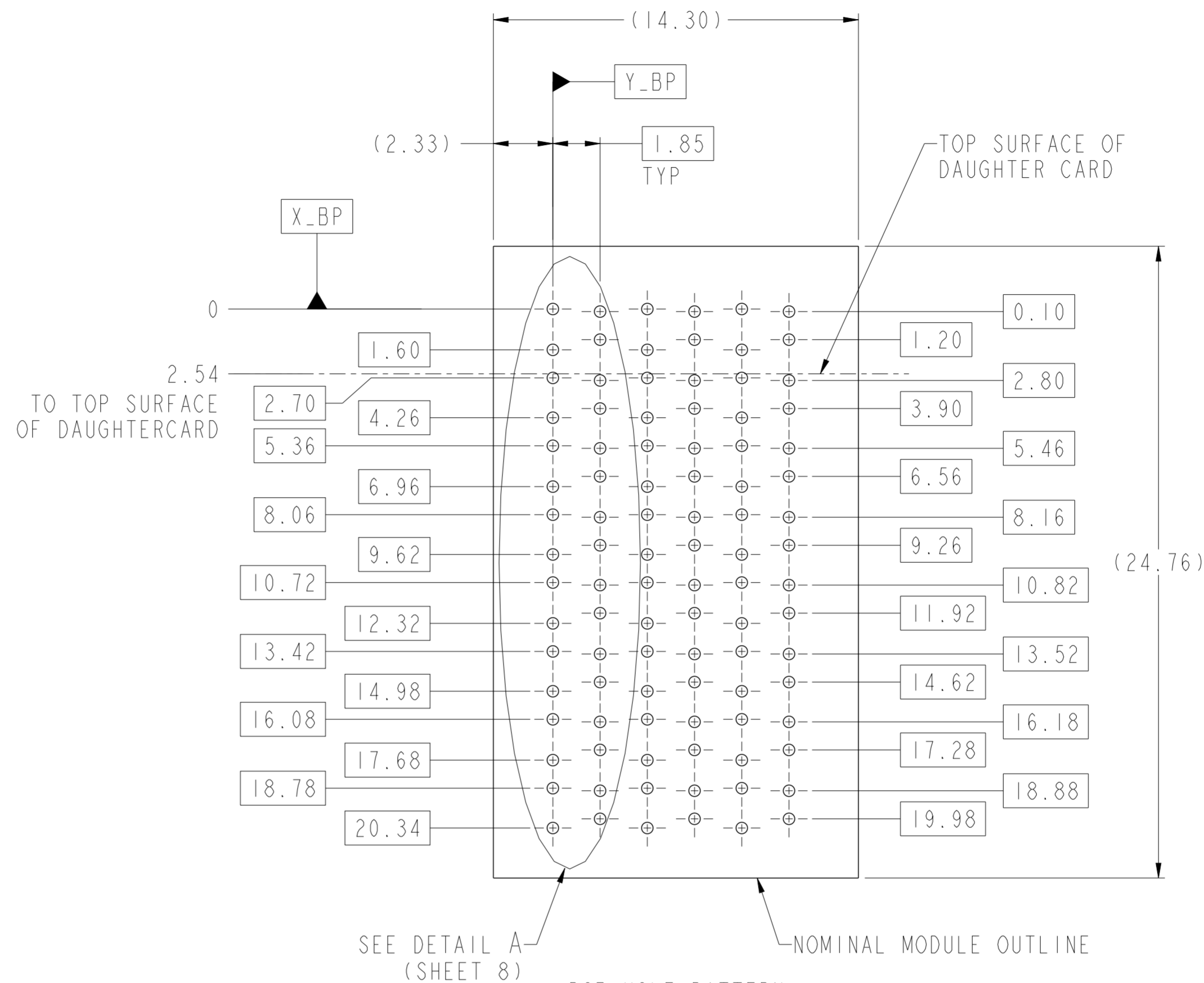
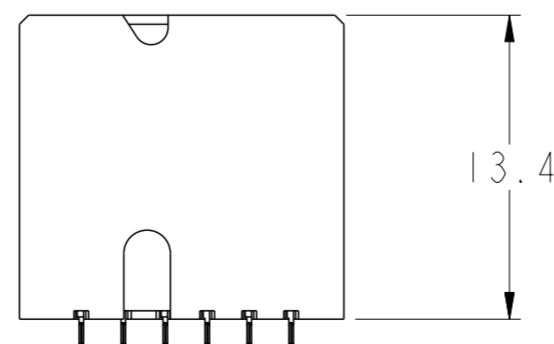
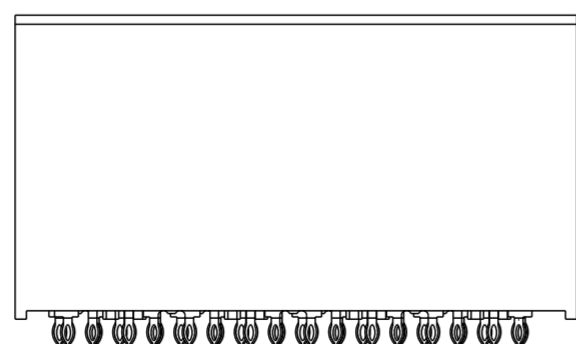
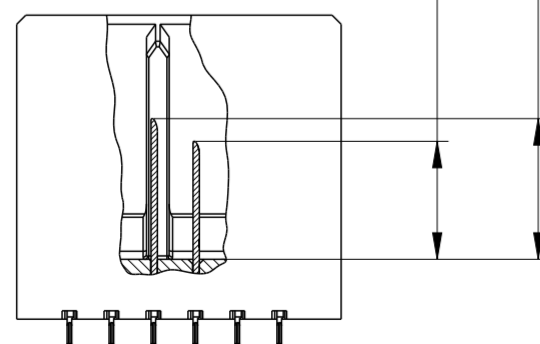

SEE DETAIL A (SHEET 8)

PCB HOLE PATTERN
COMPONENT SIDE
SCALE 6:1

spec ref	SEE NOTES	dr	Jim Swain	2009/03/02	projection	MM	size	A2	scale	3:1												
tolerance std	TOLERANCES UNLESS OTHERWISE SPECIFIED	eng	Roger Ng	2011/07/01			ecn no	ELX-S-004099-1														
ASME Y14.5		chr					rel level	Released														
surface	<table border="1"> <tr> <td>linear</td> <td>0.X</td> <td>±0.2</td> </tr> <tr> <td></td> <td>0.XX</td> <td>±0.10</td> </tr> <tr> <td></td> <td>0.XXX</td> <td>±0.050</td> </tr> <tr> <td>angular</td> <td>0°</td> <td>±°</td> </tr> </table>	linear	0.X	±0.2		0.XX	±0.10		0.XXX	±0.050	angular	0°	±°	appr	Chen-Hong Tan	2011/07/04	product family	XCode	rel level	Released		
linear	0.X	±0.2																				
	0.XX	±0.10																				
	0.XXX	±0.050																				
angular	0°	±°																				
ASME Y14.5		www.fci.com			title	MODULE ASSEMBLY			dwg no	10091767	rev	B										
		cat. no.	SEE P/N TREE	Product - Customer Drw	sheet 7 of 8																	

NOTES:

1. CONNECTOR MATERIALS
SHROUD: HIGH-TEMP THERMOPLASTIC, UL94V-0
CONTACTS: HIGH PERFORMANCE COPPER ALLOY
2. CONTACT PLATING:

SEPARABLE INTERFACE: PERFORMANCE-BASED PLATING, QUALIFIED TO MEET THE REQUIREMENTS OF FCI PRODUCT SPECIFICATION GS-12-588, INCLUDING THE TELCORDIA GR-1217-CORE (NOVEMBER 1995) CENTRAL OFFICE (CO) OR UNCONTROLLED ENVIRONMENT (UE) TEST SEQUENCE AS NOTED IN P/N TREE.

PRESS-FIT TAILS: TIN OVER NICKEL (LF), OR TIN-LEAD ALLOY OVER NICKEL (NON-LF). SEE P/N TREE.
3. PRODUCT SPECIFICATION: GS-12-588
4. APPLICATION SPECIFICATION: GS-20-121
5. PRODUCT MARKING (PART NUMBER AND LOT CODE) ON THESE SURFACES.
6. HOUSING MUST WITHSTAND EXPOSURE TO 260°C PEAK TEMPERATURE FOR 40 SECONDS IN A CONVECTION, INFRA-RED, OR VAPOR-PHASE REFLOW OVEN.
7. PACKAGING MEETS GS-14-920 LEAD-FREE LABELING SPECIFICATION.
8. NOTCH INDICATES "ROW A" SIDE OF CONNECTOR.
9. SEE APPLICATION SPECIFICATION FOR ROUTING GUIDELINES, ADDITIONAL PTH GUIDELINES, MATED DIMENSIONS, GUIDE PN SELECTION, ETC.
10. SCREW IS OPTIONAL AND ENGAGES WITH BOTTOM OF GUIDE-PIN FROM BENEATH THE PCB FOR ADDITIONAL GUIDE-PIN SUPPORT.
11. OPTIONAL HOLE LOCATION FOR GROUNDED PIN OR ADDITIONAL GUIDE-PIN SUPPORT. SEE TABLE 1 ON SHEET 1 FOR ADDITIONAL DETAILS.
12. A $\triangle B$ SYMBOL WILL BE NEXT TO ANY DIMENSION, VIEW OR NOTE THAT HAS BEEN MODIFIED WITH THE CURRENT DRAWING REVISION.

TABLE 3: PTH AND PAD SIZES WITH REFERENCE TO COMPLIANT PIN DRILL

COMPLIANT PIN DRILL	PTH	PAD
$\varnothing 0.55$ [0.0217"]	$\varnothing 0.45 \pm 0.05$	$\varnothing 0.85$
$\varnothing 0.45$ [0.0177"]	$\varnothing 0.36 \pm 0.05$	$\varnothing 0.75$

REFER TO TABLE 3 FOR PTH, DRILL & PAD SIZES

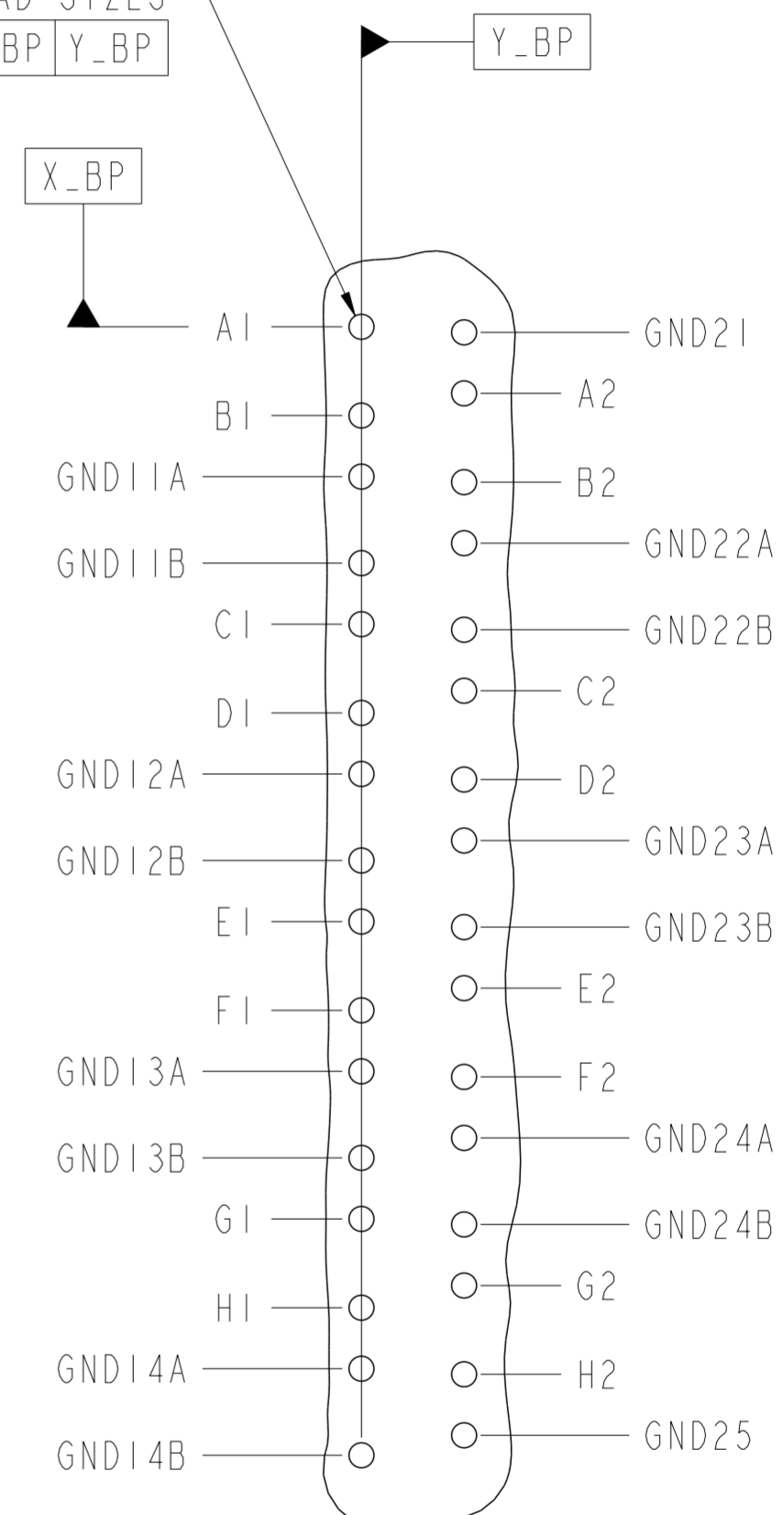
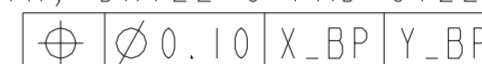

DETAIL A
SCALE 8:1

spec ref	SEE NOTES	dr	Jim Swain	2009/03/02	projection	MM	size	A2	scale	4:1									
tolerance std	TOLERANCES UNLESS OTHERWISE SPECIFIED	eng	Roger Ng	2011/07/01			ecn no	ELX-S-004099-1	rel level	Released									
ASME Y14.5		chr	-	app							Chen-Hong Tan	2011/07/04	product family	XCede					
surface	<table border="1"> <tr> <td>linear</td> <td>0.X</td> <td>± 0.2</td> </tr> <tr> <td></td> <td>0.XX</td> <td>± 0.10</td> </tr> <tr> <td></td> <td>0.XXX</td> <td>± 0.050</td> </tr> <tr> <td>angular</td> <td>0°</td> <td>\pm</td> </tr> </table>	linear	0.X	± 0.2		0.XX	± 0.10		0.XXX	± 0.050	angular	0°	\pm			TITLE MODULE ASSEMBLY VERTICAL HEADER, 6-COLUMN, 4-PAIR		dwg no 10091767	rev B
linear	0.X	± 0.2																	
	0.XX	± 0.10																	
	0.XXX	± 0.050																	
angular	0°	\pm																	
ASME Y14.5		www.fci.com		cat. no.	SEE P/N TREE	Product - Customer Drw	sheet 8 of 8												