

DEBUR AND BREAK SHARP EDGES

DO NOT SCALE DRAWING

REVISION

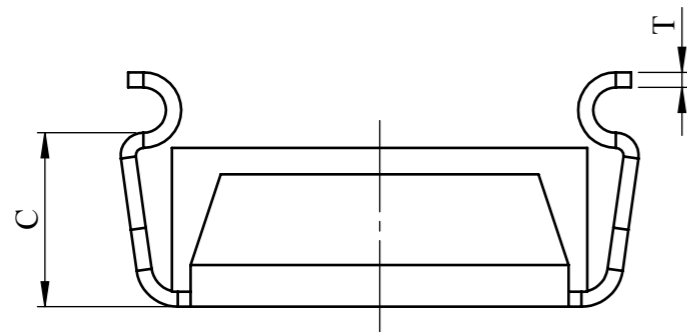
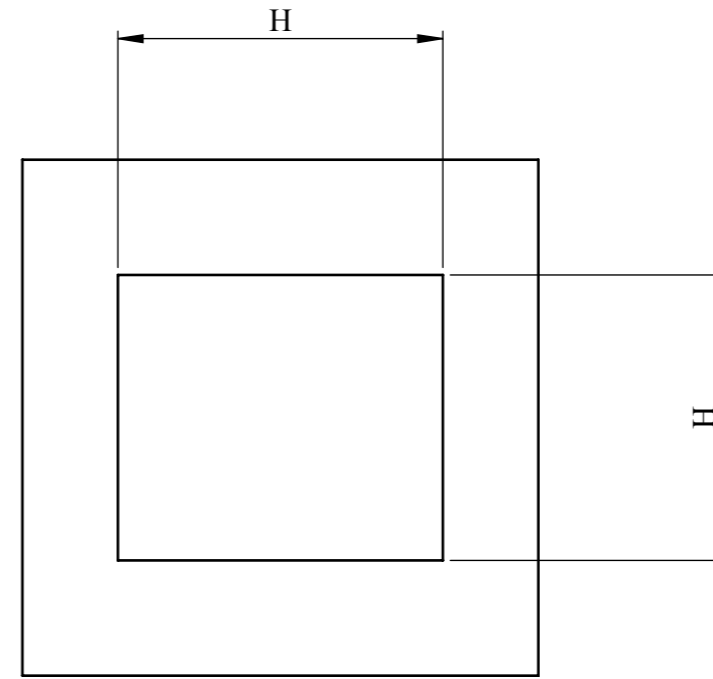
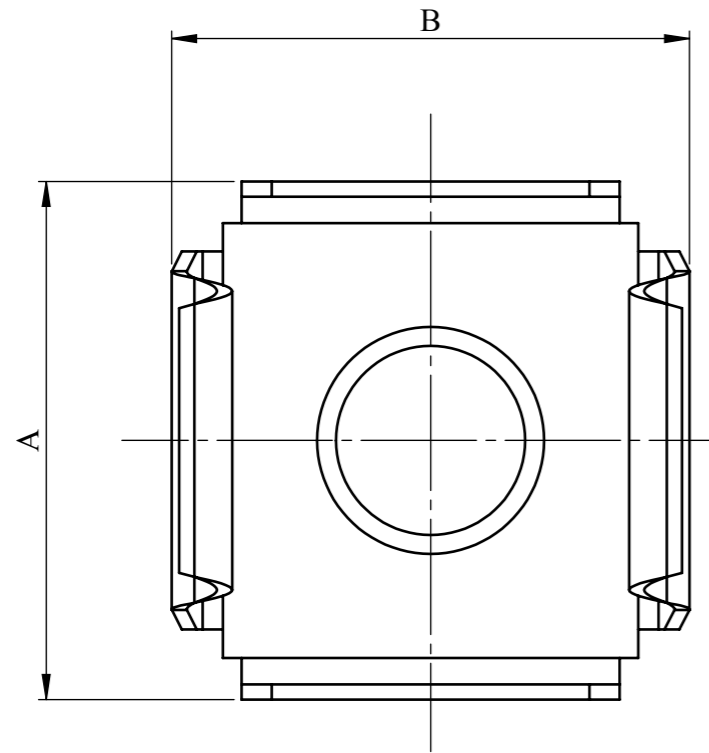

THREAD	TYPE	QTY	A	B	C	T	H
M5	NARROW	50	13.14	13.84	6.0	0.38	9.53
M5	WIDE	50	13.14	13.84	6.0	0.38	9.53
M6	NARROW	180	13.14	13.84	6.0	0.38	9.53
M6	WIDE	180	13.14	13.84	6.0	0.38	9.53

A DRAWN 26/06/15

NOTES

CAGE - CS70 CARBON SPRING STEEL  
NUT - LOW CARBON MILD STEEL



DESIGN RIGHT. TR FASTENINGS LTD, 2003  
UNDER NO CIRCUMSTANCES MUST THIS  
DRAWING BE COPIED OR DISCLOSED,  
WITHOUT FIRST OBTAINING WRITTEN  
AUTHORITY.

UNLESS OTHERWISE SPECIFIED:  
DIMENSIONS ARE IN MILLIMETERS  
SURFACE FINISH:  
TOLERANCES:

NAME	DATE
DRAWN MARTIN ELLIOTT	26/06/15
CHK'D	
APPV'D	

CUSTOMER PART No

MATERIAL:

SEE NOTES

HEAT TREATMENT

FINISH:

ZINC PLATED

TITLE:

CAGE NUT KIT

DWG NO.

TRFAKIT0006

A3

PROJECTION

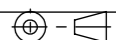

SHEET 1 OF 1