

DEBUR AND BREAK SHARP EDGES

DO NOT SCALE DRAWING

REVISION

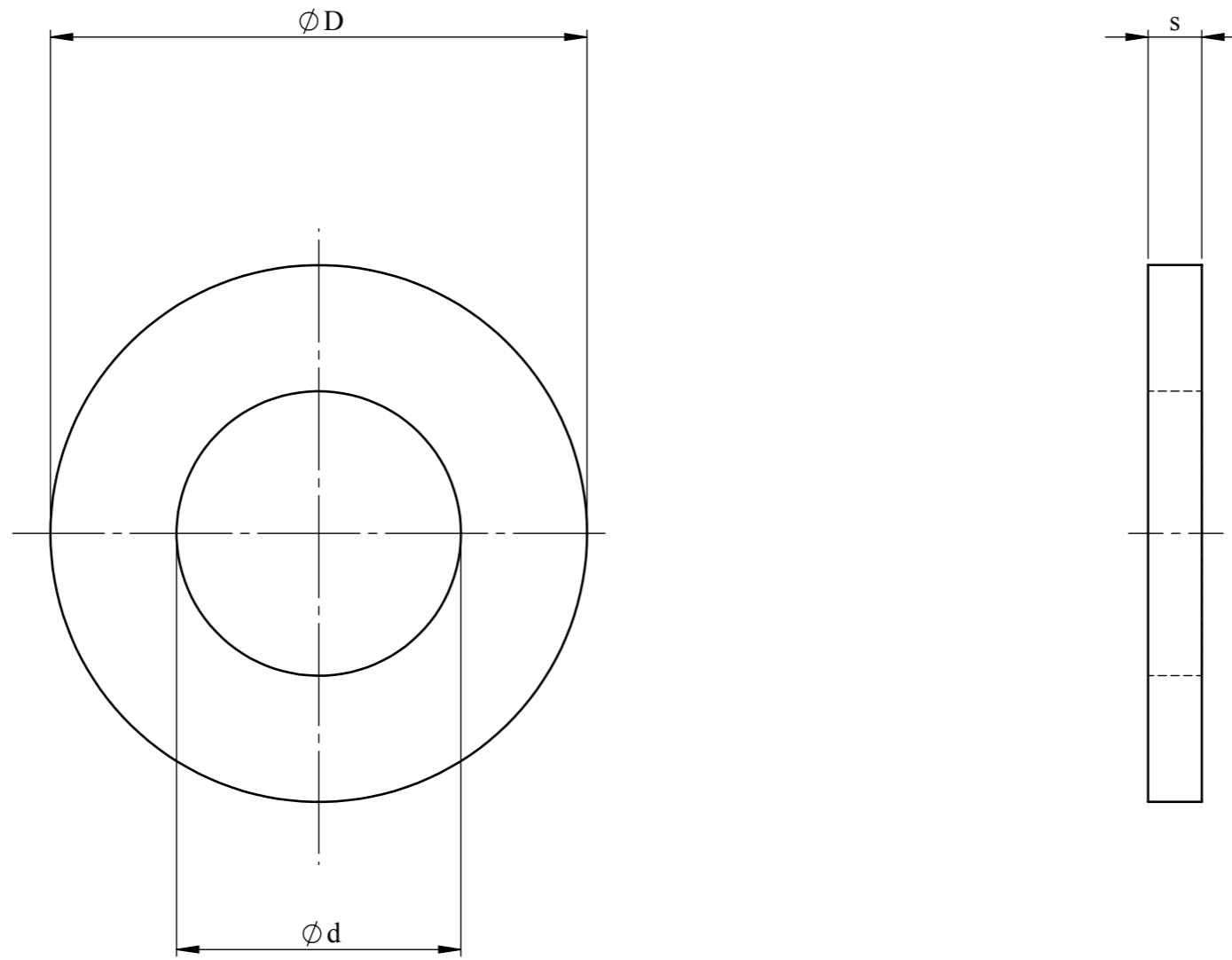

SIZE	KIT QTY	d nom	D	s nom
M2	300	2.2	5.0	0.3
M2.5	300	2.7	6.0	0.5
M3	400	3.2	7.0	0.5
M4	200	4.3	9.0	0.8
M5	200	5.3	10.0	1.0
M6	150	6.4	12.0	1.6
M8	80	8.4	16.0	1.6
M10	80	10.5	20.0	2.0
M12	80	13.0	24.0	2.5

A DRAWN 07/07/15

NOTES

DIN 125 FORM A



DESIGN RIGHT. TR FASTENINGS LTD, 2003  
 UNDER NO CIRCUMSTANCES MUST THIS  
 DRAWING BE COPIED OR DISCLOSED,  
 WITHOUT FIRST OBTAINING WRITTEN  
 AUTHORITY.

UNLESS OTHERWISE SPECIFIED:  
 DIMENSIONS ARE IN MILLIMETERS  
 SURFACE FINISH:  
 TOLERANCES:

ISO 2768 m

NAME	DATE
DRAWN MARTIN ELLIOTT	07/07/15
CHK'D	
APPVD	

CUSTOMER PART No

MATERIAL:

A2 STAINLESS STEEL

HEAT TREATMENT

FINISH:

SELF COLOUR

TITLE:

FLAT WASHER KIT

DWG NO.

TRFAKIT0009

A3

PROJECTION

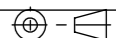

SHEET 1 OF 1