

2015/05/18 22:22:33 SRoper

参考図：ご確認用。正式には別途納入仕様書をご請求願います。

COUNT	DESCRIPTION OF REVISIONS	BY	CHKD	DATE	COUNT	DESCRIPTION OF REVISIONS	BY	CHKD	DATE
△	2	DIS-D-000591	T.S	M.Y '07.04.03	△				
△					△				
△					△				

NOTE1. This tool is for mating U.FL/N.FL SERIES plug into U.FL/N.FL SERIES receptacle. See below for how to use.

2. When mating, connector must be aligned. When go down straightly at lower level, connector pair is aligned and then push the plug with straight. Please don't do shallow-insertion.

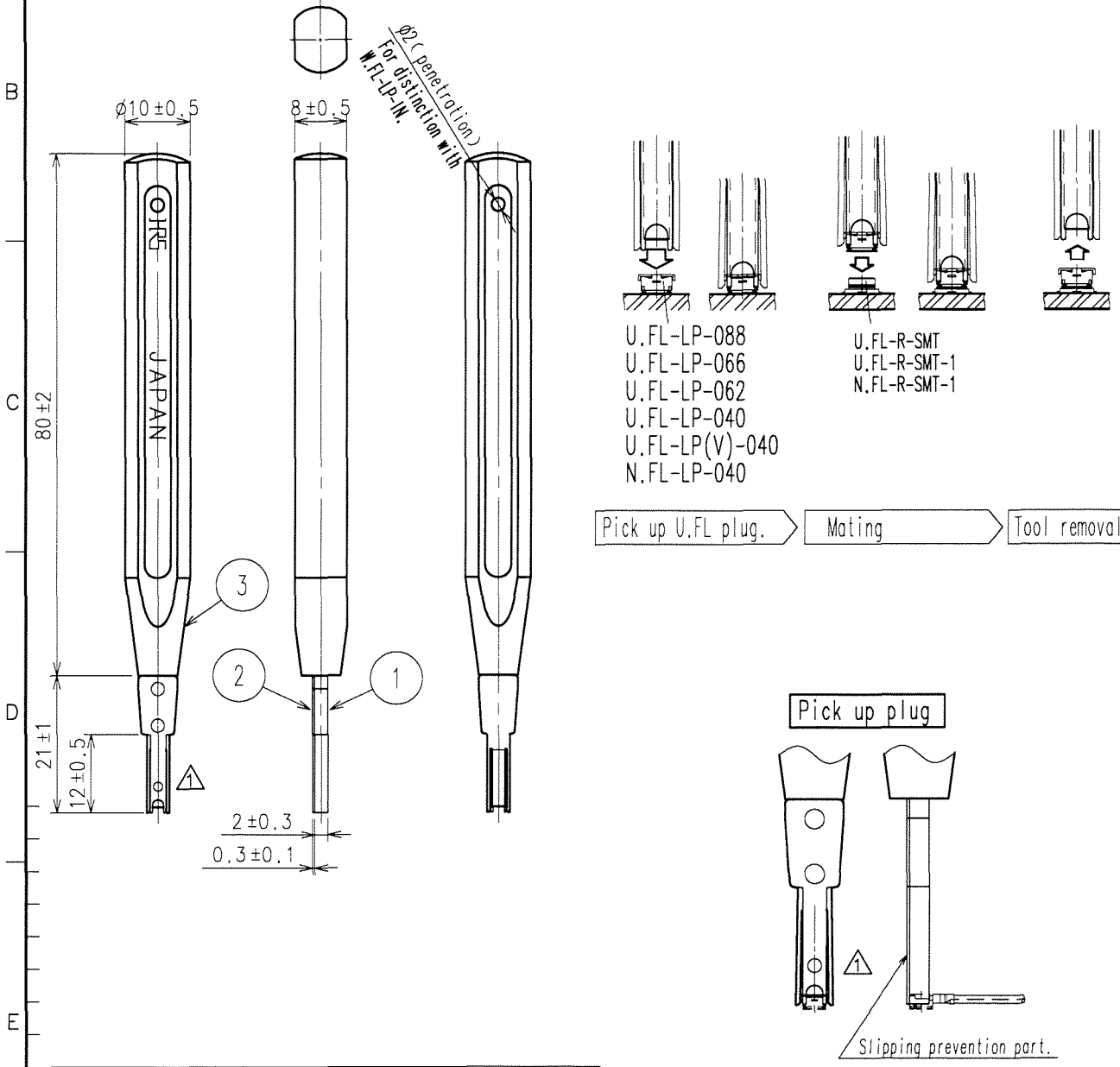

2	STEEL	NICKEL PLATING	3	POLYAMIDE	RED
1	STEEL	NICKEL PLATING			
NO.	MATERIAL.	FINISH,REMARKS	NO.	MATERIAL.	FINISH,REMARKS

CODE NO. (OLD)	DRAWN	DESIGNED	CHECKED	APPROVED	RELEASED
	T. SAWAI	T. SAWAI	N. NINOMIYA	M. YAMANE	
	'06.07.12	'06.07.12	'06.07.12	'06.07.13	

 SCALE FREE UNITS mm	DRAWING NO. EDC4-313051 HRS HIROSE ELECTRIC CO.,LTD.	PART NO. U.FL-LP-IN CODE NO. CL331-0334-9	1 1
----------------------------------	--	--	--------

TO
RF