

PART NO.	BULB TYPE	BASE TYPE	DESIGN VOLTS	DESIGN AMPS	FILAMENT TYPE	AVERAGE LIFE HOURS
112	TL3	MINIATURE SCREW E10	1.20	0.22	C-2R	5

REVISIONS			
REV	DESCRIPTION	DATE	APPROVED
1	ISSUED	04/23/2008	D.C.

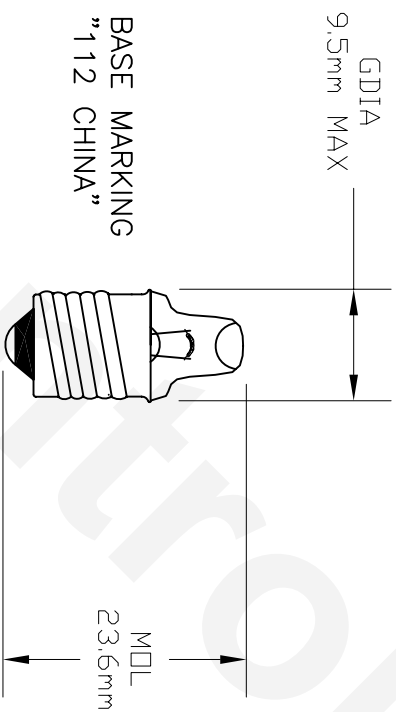

UNLESS OTHERWISE SPECIFIED: DIMENSIONS ARE IN INCHES TOLERANCES		599 BRND STREET LINCOLNSHIRE IL 60069	
DECIMALS .XX ± .05	ANGULAR ± 0.5°	CEC INDUSTRIES LTD LIGHT BULB NO. 112	
XXX ± .010 FRACTIONAL	± 1/64		
DRAWN D.C.	DATE 4/23/2008	SIZE A	FSCM NO. 112
CHECKED		SCALE	DWG NO. 112
DESIGN		PLOT SCALE	SHEET 1 OF 1
MATERIAL		FILE 112.dwg	DO NOT SCALE DRAWING