

1

2

3

4

5

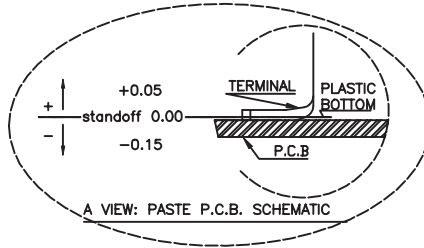
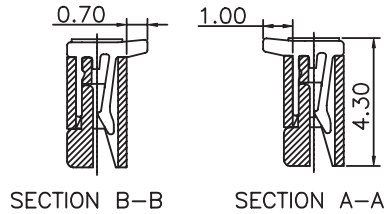

MATERIAL:
 HOUSING MATERIAL: LCP
 COLOR: IVORY
 ACTUATOR MATERIAL: LCP
 COLOR: BLACK
 CONTACT MATERIAL: PHOSPOR BRONZE
 CONTACT PLATING: 100µ TIN OVER 50µ NI
 QUALITY CLASS: 25 MATING CYCLES*

ENVIRONNEMENTAL:
 OPERATING TEMPERATURE: -25°C UP TO 85°C
 FLAMABILITY RATING: UL94-V0
 COMPLIANCE: LEAD FREE AND ROHS

ELECTRICAL:
 CURRENT RATING: 0.5A
 WORKING VOLTAGE: 50V
 INSULATION RESISTANCE: >100MOHM
 DIELECTRIC WITHSTANDING VOLT.: 250VAC/MN
 CONTACT RESISTANCE: 20mOHM MAX

STANDARD
 CERTIFIED: E323964 / MODEL NUMBER 687
 FOLLOWED BY 1, FOLLOWED BY 04 THRU 50, FOLLOWED
 BY 140 OR 145, FOLLOWED BY NUMERIC DIGITS

SOLDERING:
 REFLOW PROCESS ONLY

PACKAGING
 TAPE & REEL WITH CAP

DIMENSION:
 B = (0.50 x NB PINS) + 6.40
 C = 0.50 x (NB PINS - 1)
 D = 0.50 x (NB PINS + 1) + 0.10
 E = D - 0.10

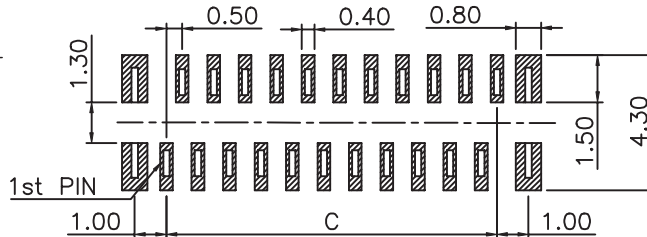
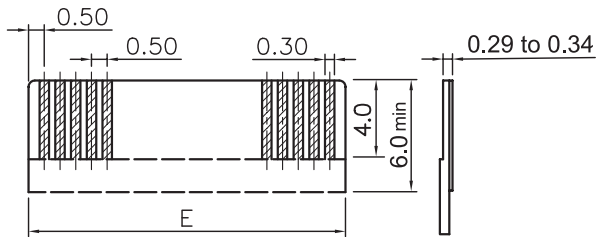
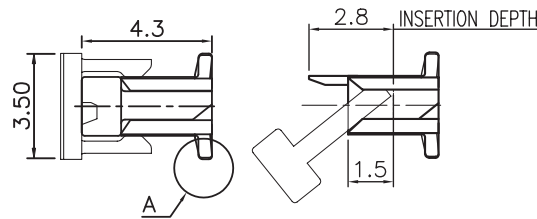
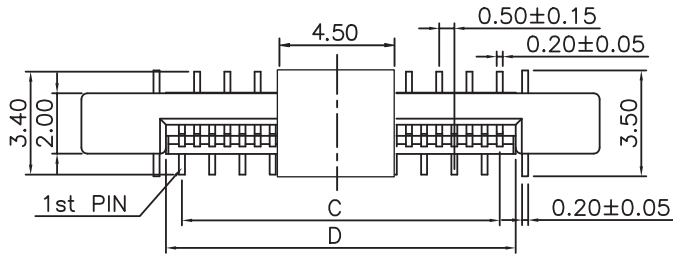
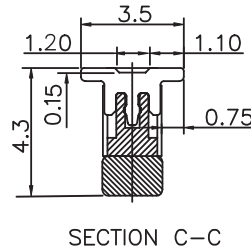
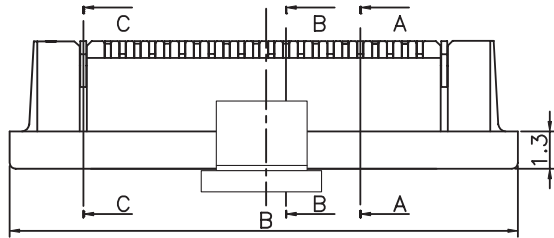

RoHS Compliant

*NOTE: theoretical value related to the Tin plating; however, due to the sensitive actuator, we recommend not to make more than 1 or 2 cycles in order to maintain acceptable mechanical & electrical conditions

PROJECTION:

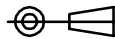

GENERAL TOLERANCE

.X = +/- 0.2

.XX = +/- 0.15



APPROVAL: RJ

UNIT: MM

SCALE:

SHEET: 1/3

DRAW: PEARL

DESCRIPTION: 0.5MM ZIF FPC VERTICAL CONTACT A TYPE - TAPE & REEL PACKAGING WITH CAP

WERI PART NO: 6873 xx 124422

SIZE

A4

I	13-DEC-13	TPK UPDATE	QL
H	18-SEP-12	MC NOTE	GG
REV	DATE	FILE	BY

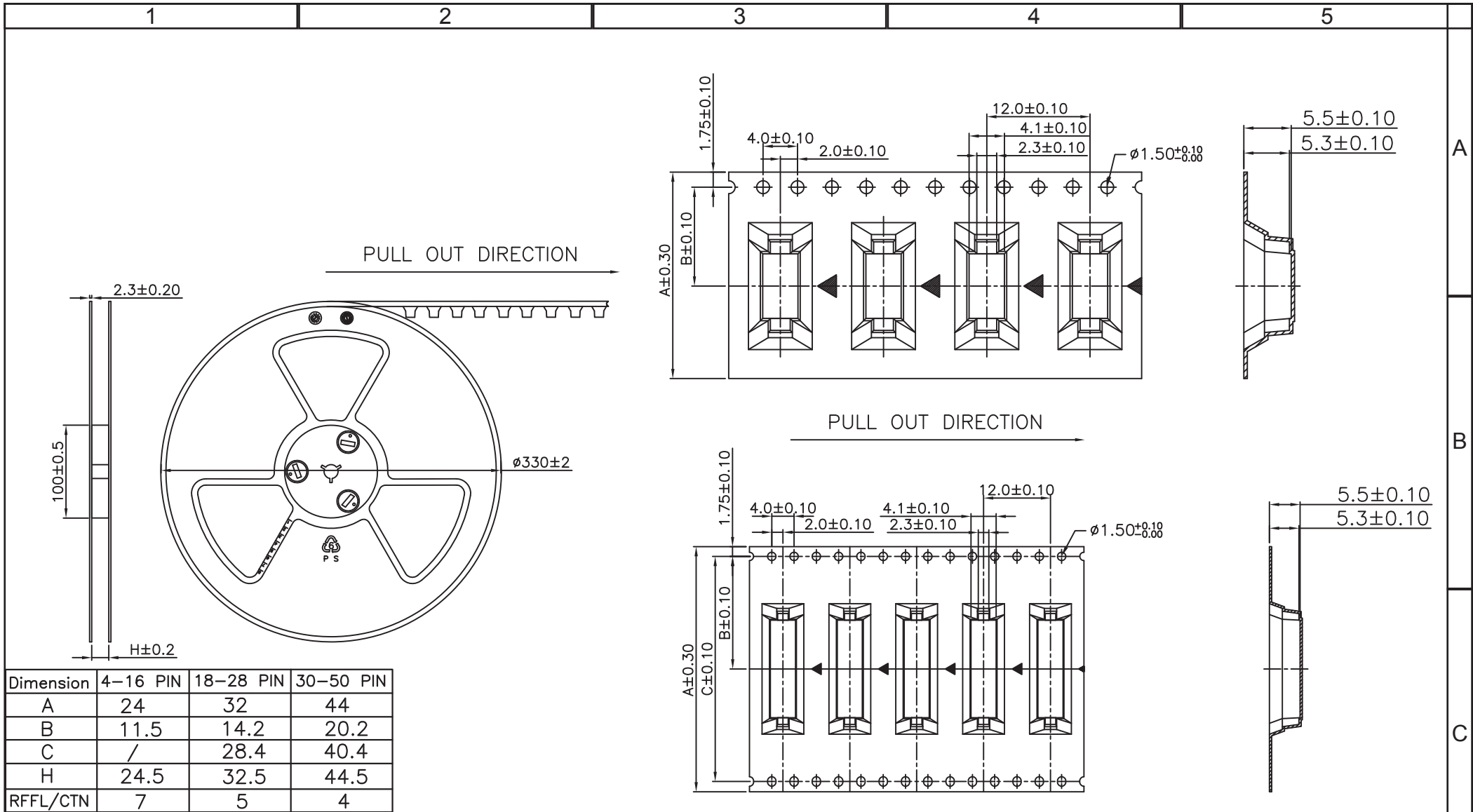

Dimension	4-16 PIN	18-28 PIN	30-50 PIN
A	24	32	44
B	11.5	14.2	20.2
C	/	28.4	40.4
H	24.5	32.5	44.5
RFFL/CTN	7	5	4

RoHS Compliant			
G			
F			
E			
D			
C			
B			
A			
REV	DATE	FILE	BY

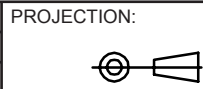

APPROVAL: RJ

GENERAL TOLERANCE
 .X = +/- 0.2
 .XX = +/- 0.15

UNIT: MM
 SCALE:
 SHEET: 2/3
 DRAW: PEARL



DESCRIPTION: 0.5MM ZIF FPC VERTICAL CONTACT A TYPE - TAPE & REEL PACKAGING WITH CAP
 WERI PART NO: 6873 xx 124422

SIZE
A4

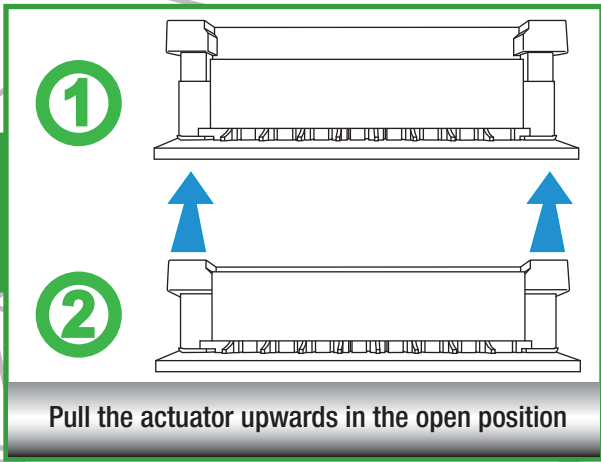

A

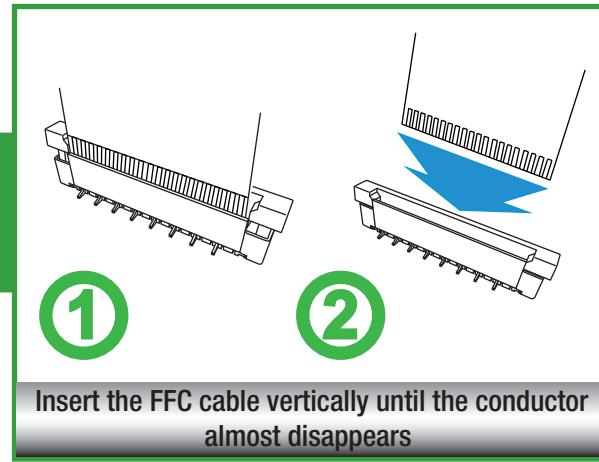

B

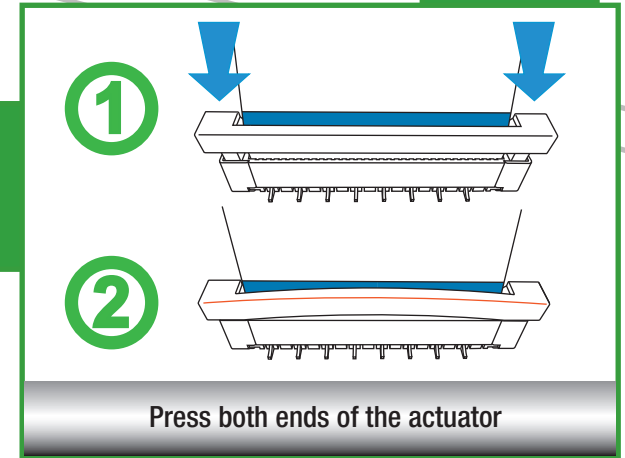
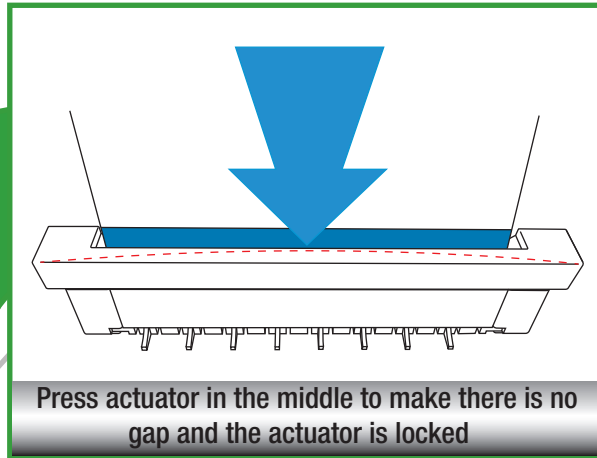

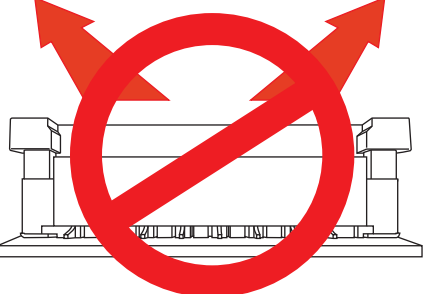

Pull the actuator as horizontally as possible by a proper force

A

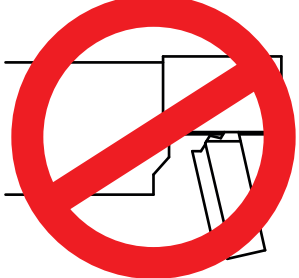

Do not pull the actuator too far otherwise the stop limit (hook on actuator) may be broken

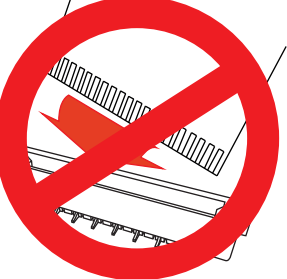

Do not keep FFC inclined when insertion

B

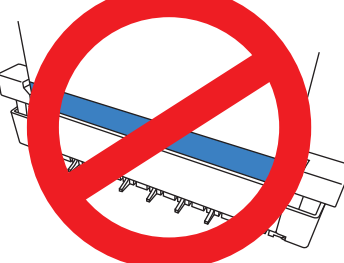

Don't keep conductor toward actuator