

THIS DRAWING IS UNPUBLISHED.

RELEASED FOR PUBLICATION APR ,2003.

LOC GP DIST 00

REVISIONS

© COPYRIGHT 2003 By -

ALL RIGHTS RESERVED.

P	LTR	DESCRIPTION	DATE	DWN	APVD
	K	REVISED PER ECO-15-006366	30APR2015	AP	SB

1 MATERIAL  
 HOUSING : THERMOPLASTIC, UL94V-0, BLACK  
 CONTACTS : BRASS.  
 SHELL : STEEL  
 SCREW : BRASS.  
 BOARD LOCK : BRASS.  
 SCREW OF TORQUE : 5 Kg-cm MAX.

2 FINISH  
 CONTACT : 15µ" MIN.GOLD PLATING ON CONTACT AREA  
 100µ" MIN. TIN PLATING ON SOLDER TAILS  
 50µ" MIN. NICKEL UNDERPLATED OVERALL  
 SHELL : 100µ" MIN NICKEL PLATING.  
 SCREW : 50µ" MIN. NICKEL PLATING.  
 BOARD LOCK : 50µ" MIN. NICKEL PLATING.

3 CHARACTERISTICS  
 CURRENT RATING : 3A  
 INSULATION RESISTANCE : 1000MOHMS MIN, 500VDC FOR 2MINS.  
 TEMPERATURE RATING : -55DEGC ~ +105DEGC  
 VOLTAGE RATING : 250VDC

4 OBSOLETE PARTS: OBSOLETE CIS STREAMLINING PER D.RENAUD/D.SINISI.

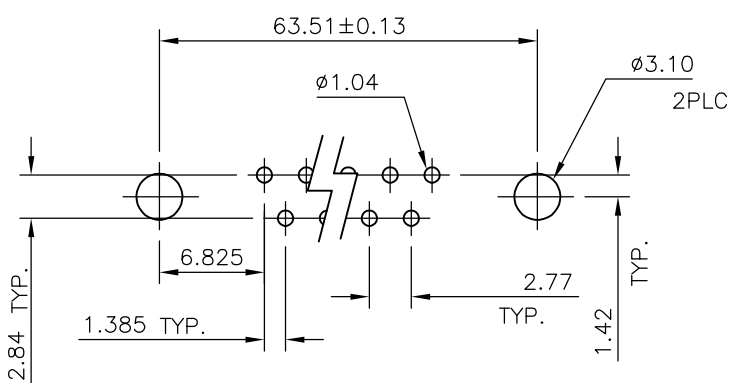
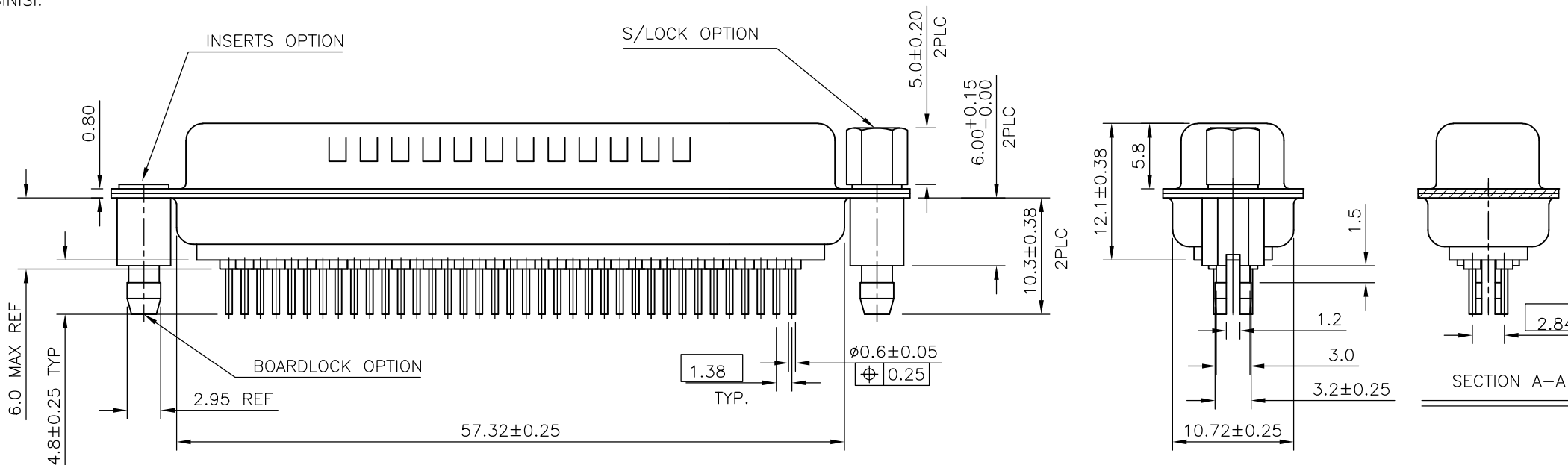
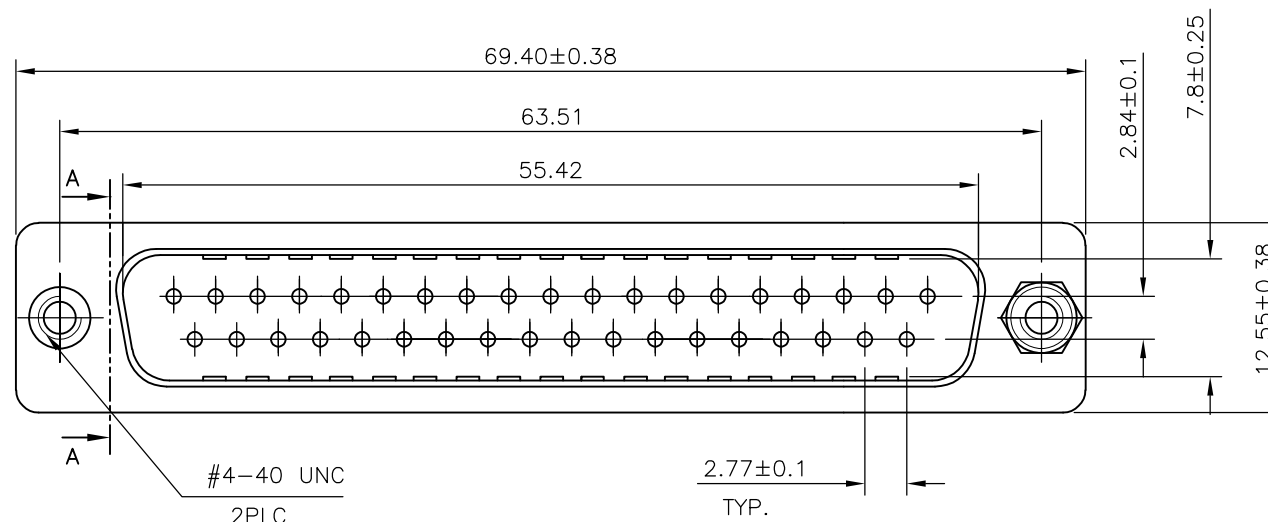

RECOMMENDED PCB LAYOUT(TOP VIEW)  
 (PCBTOLERANCE : ±0.05)

4	OBSOLETE	37W D PLG WITH B/L & M3 S/LOCK 15µ" GOLD	4-1634221-2
		37W D PLG WITH B/L & 4-40 S/LOCK 15µ" GOLD	3-1634221-2
4	OBSOLETE	37W D PLG WITH B/L & M3 INSERTS 15µ" GOLD	2-1634221-2
	OBSOLETE	37W D PLG WITH B/L & 4-40 INSERTS 15µ" GOLD	1-1634221-2
		DESCRIPTION	TE PART NO.

THIS DRAWING IS A CONTROLLED DOCUMENT.		DWN J.SANDWELL 10APR03	TE Connectivity		
DIMENSIONS: mm		CHK R.DYER 10APR03			
TOLERANCES UNLESS OTHERWISE SPECIFIED:		APVD F.WHEELER-KING 10APR03	NAME		
0 PLC ± -		PRODUCT SPEC	D-SUB HD20, VERTICAL, 37P PLUG CONNECTOR		
1 PLC ± 0.25		APPLICATION SPEC	SIZE	CAGE CODE	DRAWING NO
2 PLC ± 0.15			A300779		C-1634221
3 PLC ± -			RESTRICTED TO		
4 PLC ± -		WEIGHT -	SCALE 2:1 SHEET 1 OF 2 REV K		
ANGLES ± 3'			CUSTOMER DRAWING		
FINISH -					

THIS DRAWING IS UNPUBLISHED.

RELEASED FOR PUBLICATION APR , 2003.

© COPYRIGHT 2003 By -

ALL RIGHTS RESERVED.

LOC GP DIST 00

REVISIONS

P	LTR	DESCRIPTION	DATE	DWN	APVD
-	-	SEE SHEET 1	-	-	-

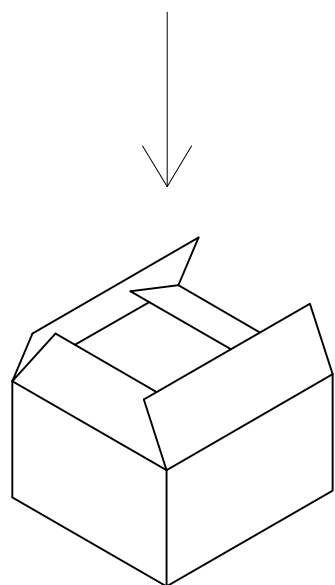
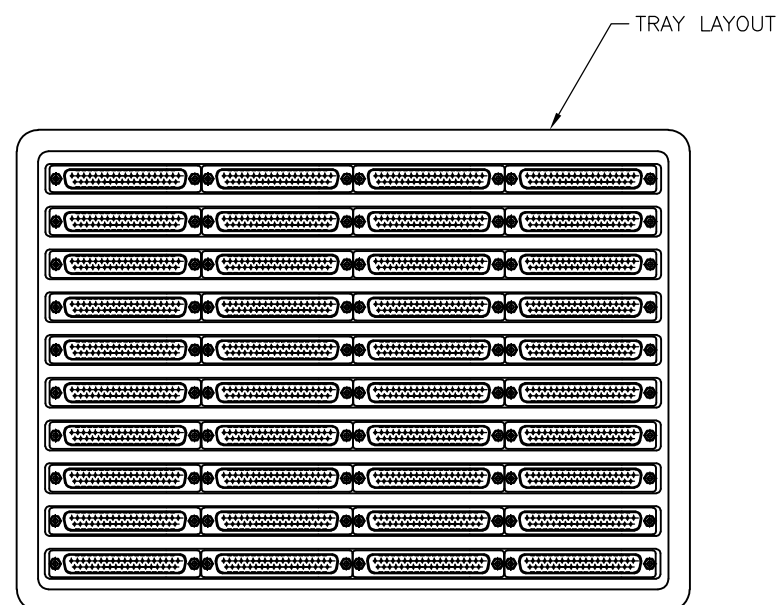
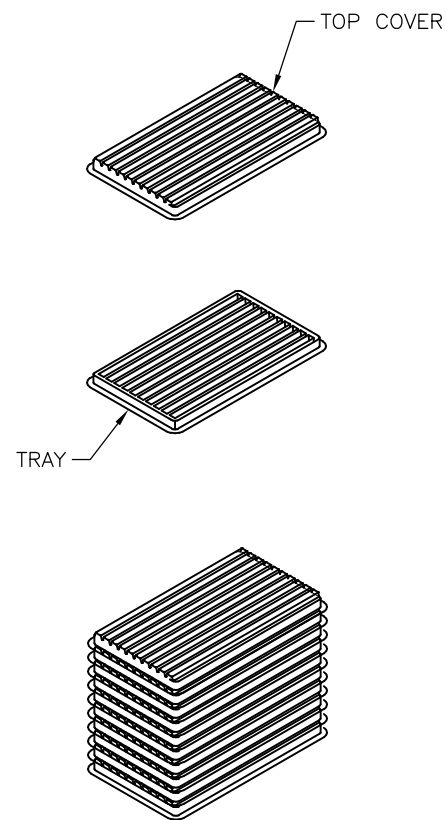

MATERIAL

- 1 TRAY: PVC
- 2 SHIPPING CARTON: CORRUGATED FIBERBOARD

DIMENSIONS

- 1 TRAY: L=310, W=230, H=21
- 2 SHIPPING CARTON: L=330, W=245, H=160

QUANTITY

- 40 PCS/TRAY
- 10 TRAY/SHIPPING CARTON

THIS DRAWING IS A CONTROLLED DOCUMENT.		DWN J.SANDWELL 10APR03	<b>STE</b> TE Connectivity		
DIMENSIONS: mm		CHK R.DYER 10APR03			
TOLERANCES UNLESS OTHERWISE SPECIFIED:		APVD F.WHEELER-KING 10APR03	NAME D-SUB HD20, VERTICAL, 37P PLUG CONNECTOR		
0 PLC ± -		PRODUCT SPEC	-		
1 PLC ± 0.25		APPLICATION SPEC	-		
2 PLC ± 0.15		WEIGHT	-		
3 PLC ± -		CUSTOMER DRAWING	SIZE A3	CAGE CODE 00779	DRAWING NO C-1634221
4 PLC ± -		FINISH	SCALE 2:1	SHEET 2 OF 2	RESTRICTED TO -
ANGLES ± 3°			REV K		
MATERIAL -					